

# Start Line MS 201



de Originalbetriebsanleitung  
Reifenmontiermaschine

en Original instructions  
Tire changer

fr Notice originale  
Machine à monter les pneus

es Manual original  
Máquina para montaje de neumáticos

it Istruzioni originali  
Smontagomme

pt Manual original  
Máquina de montagem de pneus

de EU-Konformitaterklæring  
en EU-Declaration of Conformity  
Fr. Declaración de conformidad "CE"  
es. Declaración de conformidad CE

it. Dichiarazione di conformità CE  
sv. EG-försäkran om överensstämmelse  
da. EF-klaringsattest  
nl. EG-conformiteitsverklaring

pt. Declaração CE de conformidade  
hr. EZ izjava o sukladnosti  
no. EU-samsvareiserklæring

### Start Line MS 201

Reifenmontiermaschinen  
Type changing machines  
Machines de montage de pneus  
Máquinas montanematósicos  
Monta-smonta pneumatici  
Däckmontiermaschinen  
Däckmontiermaschinen  
Bandenmonteer machines  
Máquinas de montagem de pneus  
Strojovi za montažiranje guma  
Dekkomteringsmaskiner

Der oben beschriebene Gegenstand der Erklrung erfllt die einschlagigen Harmonisierungsvorschriften der Europischen Union. Die allenjhrliche Verantwortung fr die Ausstellung dieser Konformittsbekrfung trgt der Hersteller. Diese Erklrung beschrnkt sich auf die Uberinstimmung mit den genannten Richtlinien, ist jedoch keine Zusicherung von Eigenschaften. Die Sicherheits Hinweise der mitgelieferten Produktdokumentation sind zu beachten.

The a.m. object of declaration fulfils the relevant harmonization legislation of the European Union. This declaration of conformity is issued under the sole responsibility of the manufacturer. This declaration certifies compliance with the stated directives, but it does not provide any assurance of characteristics. The safety instructions of the product documentation included are to be observed.

L'objet susnomme de la dclaration rpond  la lgislation communautaire d'harmonisation en vigueur de l'Union Europenne. Le fabricant est seul et uniquement responsable de l'missionnement de cette dclaration de conformit. La prsente dclaration certifie,  l'gard des directives indiques dans la documentation technique, l'quivalence de caractristiques. Observer les consignes de scurit qui figurent dans la documentation technique.

El objeto de la declaracin describe anualmente es conforme a la legislacin de armonizacin pertinente de la Unin Europea. El fabricante es el nico responsable de la emisin de esta declaracin de conformidad. Esta declaracin certifica la conformidad con las directivas mencionadas, pero no supone ningn garata de propiedades. Deben leerse en su totalidad las indicaciones de seguridad de la documentacin del producto suministrado adjunta.

Loggito sopra descritto della dichiarazione soddisfa le normative di armonizzazione vigenti dell'Unione Europea. La responsabilit inerente al rilascio della presente dichiarazione di conformit ricade interamente sul fabbricante. Questa dichiarazione attesta la conformit alle direttive citate, senza tuttavia costituire alcuna certificazione di qualit. Devono essere seguite le avvertenze contenute nelle documentazioni del prodotto allegato.

Frenskt for frskan om overensstmmelse med den relevanta harmoniserade unionslagstiftningen. Tillverkaren br hela ansvaret fr utstndandet av denna frskan om overensstmmelse. Denna frskan inbegyter overensstmmelse med de tttamnda riktlinjerna, men r inte en frskan om egenskaper. Skerhetsanvisningarna som ingr i den medleverade produktdokumentationen s fljs.

Ovenfor beskrevne genstand i erklringen opfylder de relevante harmoniseringsretskrifter i Den Europiske Union. Producenten bærer alene ansvaret for udstedelsen af denne overensstmmelseserklring. Denne erklring attesterer overensstmmelsen med de nvnte direktiver, er dog ingen garanti for egenskaber. Skerhedsanvisningerne i den medleverede produktdokumentation s overholdes.

Het hierboven beschreven object van de verklaring voldoet aan de geldende harmonisatievoorschriften van de Europese unie. Allen de fabrikant is verantwoordelijk voor het opstellen van deze conformiteitsverklaring. Deze verklaring bevestigt overensstemming met de genoemde richtlijnen, het is echter geen garantie van eigenschappen. Houdt u aan de veiligheidsaamwijzingen van de meegeleverde productdocumentatie.

O objeto de declaracin acima descrito est em conformidade com a legislao de harmonizao da Unio Europeia aplicvel. A presente declarao de conformidade  emitida sob a exclusiva responsabilidade do fabricante. Esta declarao certifica a conformidade com as normas referidas, mas no garante por si determinadas caractersticas. As instrues de segurana da documentao do produto fornecida junto devem ser respeitadas.

A nyilatkozat fenntartotttgra megfelel az Eurpi Uni idevlegs harmonizacios jogszablyoknak. Ennek a megfelelsg nyilatkozatnak a killitstst  egynl  a gyrttnk vs. Ez a nyilatkozat tartalmazza a megadott irnyelvkeltt valt egyezst, de nem garatlja a tulajdonsgokat. Vegyt figyelembe az a dttdot tennk dokumentacon szereplo biztonsg utasitsokat.

Prehodo opisano predmet ove izjave u skladu je s odgovarajuim uskladnim pravim propisima Europske unije. Proizvoak proizvoak snosi isključivo odgovornost za izdavanje ove izjave o sukladnosti. Ova izjava dokazuje usklađenost s navedenim Direktivama, no ne predstavlja jamstvo za svojstva. Mora ju se poštovati sigurnosne napomene u priloženom dokumentaciji proizvoda.

Den ovenfor beskrevne gjenstanden av erklringen oppfyller de gjeldende harmoniseringsforskrifene til EU. Produzenten er eneansvarlig for oppretteelse av denne samsvarserklringen. Denne erklringen bekrefter samsvar med direktiver som nevnes ovenfor, men er ingen garanti for egenskaper. Sikkerhetsanvisningene til den medleverte produktdokumentasjonen m fljs.

Datum/Date - Rechtsverbindliche Unterschrift / Legally binding Sign  
Desa: AA-AS-SVV Richard Wagner  
(Sales)

18.7.2016 Ma. 

Datum/Date - Rechtsverbindliche Unterschrift/ Legally binding Sign  
AA-AS/RW8, Marco Kempin  
(Marketing, person responsible for documents)†  
Robert Bosch GmbH, Franz-Oeschle-Str. 4, 73071 Plochingen, GERMANY



Beissbarth GmbH  
Ein Unternehmen der Bosch Gruppe  
Hannauer Strae 101  
80993 Mnchen (Munich, Bavaria)  
DEU/SCHLAND

1 695 974 062 | 05.07.2016 AA-AS/EWT2-EU

- MD 2006/42/EC** (OJ L 157, 09.06.2006, p. 24-86): Maschinrichtlinie / Machine Directive / Directive Machines / Directiv de mașinas / Direktiva relative alle maskine / Maskindirektiv / Maskineriktlinje / Direktiv Máquinas / Gępitnyelv / Direktiva o strojevima / Maschinrichtlinie
- EMC 2014/53/EU** (OJ L 96, 29.03.2014, p. 79-108): EMV-Richtlinie / EMC Directive / Compatibilitate electromagnetic / EMV-Richtlijn / Direktiva EMK o elektromagnetnoj kompatibilitosti / EMC-direktiv
- CEM / EMC-direktiver / EMC-direktiv / EMC-richtlijn / Direktiv EMC** Compatibilitate electromagnetic / Electromagnetic Compatibility (EMC) Directive / EMC Directive / EMC-richtlijn / Direktiv EMC / EMC-direktiv
- PEP 2014/68/EU** (OJ L 98, 27.06.2014, p. 164-239): Druckertlle-Richtlinie / Pressure Equipment Directive / Directive sur les quipements sous pression / Direktiva sobre equipos a presin / Direktive in materia de atrziatre a presine / Druckertlle-Richtlinie / Mgyleltss direktiva o ltno optn / Trnyksty-direktv / stk 3eur.3
- Berannte Stelle / Notified body :  
Dokumentnummer / Refer to document number:  
**SPVD 2014/29/EU** (OJ L 96, 29.03.2014, p. 45-78): Einfache Druckertlle-Richtlinie / Simple pressure vessels Directive / Directive sur les quipements sous pression / Direktiva sobre equipos a presin / Direktive in materia de atrziatre a presine / Druckertlle-Richtlinie / Mgyleltss direktiva o ltno optn / Trnyksty-direktv stk 3eur.3

Jahr der erstmaligen CE-Kennzeichnung / Year of the first marking CE / Anee de premier marquage CE / 16

Year of the first marking CE / Anee de la prima marcare CE / A for first CE marking / Year of the first marking CE / Anee de la prima marcare CE / A for first CE marking / Year of the first marking CE / Anee de la prima marcare CE / A for first CE marking

Die Konformitt wird nachgewiesen durch die Einhaltung folgender einschlagig harmonisierter Normen:  
Conformity is documented through adherence to the following harmonized standards:

La conformit est dmontre par le respect des normes harmonises suivantes:  
La conformit queda demostrada mediante el cumplimiento de las siguientes normas armonizadas:  
Overensstmmelsen bevises gennem at fljende harmoniserede standarder llignes:

Konformiteten dokumenteres ved overholdelsen af flgende harmoniserede standarder  
De conformitt wordt bevestigd door het naleven van de volgende geharmoniseerde normen:  
A conformidade  comprovada pelo cumprimento das seguintes normas harmonizadas:

Usklađenost se dokazuje pridržavanjem slijedeih usklađanih normi:  
Samsvart pvises gjennom overholdelse av flgende harmoniserte standarder:  
**EN ISO 12100:2010; EN 60204-1:2006+A1:2009+A2:2010; EN ISO 4414:2010**  
**EN 61000-6-2:2005+A2:2005; EN 61000-6-3:2007+A1:2011+A2:2012**

Angewendete nationale Normen und technische Spezifikationen und/oder Angaben zu Baugruppen gem Druckgertichtlinien:  
Applied national standards and technical specifications and/or data on the modules as per the pressure equipment directive:  
Normas nacionales  especificaciones tcnicas aplicadas e/ou indicaes relativas aos seus grupos conformment  la PED:  
Normas nacionales aplicadas y especificaciones tcnicas u/o informacin relativa a los conjuntos conforme a la directiva PED:  
Norme naionale aplicate e caracteristice tehnice e/o dati su grupuri in conformittt alle PED:  
Tlmptate naionale standarde og tekniske specifikationer og/eller angivelser om komponenter iht. direktiverne om trykapparater  
Avervante nationale normen en teknische specificaties en/of gegevens over componenten conform de richtlijnen voor printers:  
Normas e especificaes tcnicas nacionais aplicadas/e/ou dados sobre mdulos, de acordo com as directivas relativas aos equipamentos sob presso:  
Alkalmazott nemzeti mszaki szabvnyok s specifikcks s/vagy adatok szerkezeti modulokhoz nyomtrstorozo eszkzk irnyelvk szerint:  
Prihujene nationalne norme i tehnike specifikacije i/ili podaci i o sklopuvima sukladno Direktivi o strojevima:  
Avervante nasjonalne standarder og tekniske spesifikasjoner og/eller angivelser om komponentgrupper i henhold til direktivet for trykkstyt:

## Content English

<b>1. Symbols used</b>	<b>28</b>	7.8 Mounting the tire	41
1.1 In the documentation	28	7.8.1 Selecting the tire	42
1.1.1 Warning notices - Structure and meaning	28	7.8.2 Preparing the tire	42
1.1.2 Symbols in this documentation	28	7.8.3 Positioning of the mounting head	42
1.2 On the product	28	7.8.4 Mounting the lower tire bead	42
1.3 Warning	28	7.8.5 Mounting the top bead	42
<hr/>		7.9 Procedure for mounting/demounting alloy rims	43
<b>2. User instructions</b>	<b>29</b>	<b>8. Inflation</b>	<b>43</b>
2.1 General provision	29	8.1 Inflating tubeless tires	44
2.2 Range of application	29	8.2 Inflating tubed tires	44
2.3 Safety requirements and notes	30	<hr/>	
<hr/>		<b>9. Maintenance</b>	<b>45</b>
<b>3. Product description</b>	<b>31</b>	9.1 Warning	45
3.1 Intended use	31	9.2 Maintenance operations	45
3.2 Machine rating plate	31	9.2.1 Maintenance unit and bead breaking cylinder	45
3.3 Device description	31	9.2.2 Belt	46
<hr/>		<hr/>	
<b>4. Transport</b>	<b>32</b>	<b>10. Troubleshooting</b>	<b>47</b>
4.1 Transport and packing	32	<hr/>	
4.2 Transport method	32	<b>11. Decommissioning</b>	<b>48</b>
<hr/>		11.1 Change of location	48
<b>5. Unpacking</b>	<b>32</b>	11.2 Temporary shutdown	48
5.1 Unpacking	32	11.3 Disposal and scrapping	48
5.2 Setting up the MS 201	32	11.3.1 Substances hazardous to water	48
3.4 Scope of delivery	32	11.3.2 MS 201 and accessories	48
<hr/>		<hr/>	
<b>6. Initial commissioning</b>	<b>34</b>	<b>12. Technical Parameter</b>	<b>49</b>
6.1 Initial commissioning	34	12.1 Dimensions for	49
6.2 Fastening the MS 201	35	12.2 Range of application	49
6.3 Connecting the MS 201 to power and the compressed air supply	35	12.3 Turntable type	49
6.4 Checking the pedal functions	35	12.4 Bead breaker blade	49
<hr/>		12.5 Power	49
<b>7. Operation</b>	<b>36</b>	12.6 Pneumatic diagram	49
7.1 Safety notice	36	<hr/>	
7.2 Check before use	36		
7.3 Information about special rims and tires	36		
7.4 Unseating the tire bead	37		
7.5 Rim location direction	38		
7.6 Clamping the rim	39		
7.6.1 Clapping the rim from the outside:	39		
7.6.2 Clamping the rim from the inside:	39		
7.7 Demounting the tire	39		
7.7.1 Positioning of the mounting head	40		
7.7.2 Lever the top bead over the rim flange	40		
7.7.3 Demounting the top bead	41		
7.7.4 Demounting the bottom bead (with the aid of the mounting head)	41		
7.7.5 Removing wheels	41		

# 1. Symbols used

## 1.1 In the documentation

### 1.1.1 Warning notices - Structure and meaning

Warning notices warn of dangers to the user or people in the vicinity. Warning notices also indicate the consequences of the hazard as well as preventive action. Warning notices have the following structure:

Warning symbol **KEY WORD – Nature and source of hazard!**  
 Consequences of hazard in the event of failure to observe action and information given.  
 ➤ Hazard prevention action and information.

The key word indicates the likelihood of occurrence and the severity of the hazard in the event of non-observance:

Key word	Probability of occurrence	Severity of danger if instructions not observed
<b>DANGER</b>	<b>Immediate danger</b> impending	<b>Death or severe injury</b>
<b>WARNING</b>	<b>Possible danger</b> impending	<b>Death or severe injury</b>
<b>CAUTION</b>	Possible <b>dangerous situation</b>	<b>Minor injury</b>

### 1.1.2 Symbols in this documentation

Symbol	Designation	Explanation
!	Attention	Warns about possible property damage.
i	Information	Practical hints and other useful information.
1. 2.	Multi-step operation	Instruction consisting of several steps.
➤	One-step operation	Instruction consisting of one step.
↪	Intermediate result	An instruction produces a visible intermediate result.
→	Final result	There is a visible final result on completion of the instruction.

## 1.2 On the product

! Observe all warning notices on products and ensure they remain legible.



### Danger – Attention electricity !

Risk of injuries, heart failure or death from electric shock when touching live parts (e. g. main switch, circuit boards).

- Work on electrical installations or equipment is only to be performed by qualified electricians.
- Cut the power supply to the MS 201 before opening it.



### Direction of wheel rotation

Wheel must turn in direction indicated.

## 1.3 Warning



**Wear safety goggles.**



**Study the original operating instructions prior to operation.**



**Risk of injury from rotating and moving parts.**



## 2. User instructions

### 2.1 General provision

- This operating manual is an essential part of the product. Before operating the device, please read and heed the warnings and instructions in the operating manual. It contains important information on safe operation and maintenance.
- Leave the operating instructions and warnings in the operating manual and on the MS 201. Please keep this operating manual in a safe location for use at a later date and in its entirety in the event the device is sold.
- If the operator reads the operating manual carefully, the operator can operate the MS 201 correctly and safely.
- Please read the operating manual carefully before connecting the voltage supply and compressed air supply.
- Please carefully retain all information and data supplied and provided.
- Different tire changers come with different operating manuals. The operator must check that the operating manual is the correct one for the device.

**!** The MS 201 must be used for the purpose stated in the operating manual. The manufacturer and its authorized dealers assume no responsibility for problems caused by incorrect operation.

**!** The MS 201 must be operated by technically capable personnel. The operator must fully understand the operating manual and have received professional training. If untrained personnel operate the MS 201, personal injury and damage to the tire and rim may result.

**!** The MS 201 has been designed for use by personnel with basic mechanical and electrical skills. For this reason, the description of basic operations such as how to tighten screws may not appear in the operating manual. Never allow inexperienced personnel to operate the MS 201. If you have any questions in this regard, please contact your authorized dealer for assistance.

**i** All of the figures in the operating manual show the MS 201 in its original design. The structure shown may be different from the actual structure of the machine.

### 2.2 Range of application

The MS 201 is an electropneumatic tire changer for passenger cars. Information about the work area (weight/size) can be found in the Technical Data section.

#### Applicable tire types:

- Tire standard tire
- Reverse tire
- Tire without center hole
- Run flat tire (with assist arm)

**!** Each type of tire has its own specific method of operation.

**!** Notice: When demounting / mounting the tire of an old car (more than 30 years old) / modified car tires / tires with a modified rim, accidents may happen.

### 2.3 Safety requirements and notes

- The MS 201 must only be operated by authorized personnel who have received special training.
  - The manufacturer assumes no liability for any direct or indirect damage arising from modification of the MS 201 without the permission of the manufacturer.
  - The MS 201 machine comes from the factory with a complete set of instructions and warning signs. If for some reason these have been damaged or destroyed, they must be replaced.
  - The MS 201 must be kept away from flammable and explosive materials.
  - The MS 201 must also be kept out of direct sunlight and glare.
  - The installation site must be well ventilated.
  - Be sure to use original parts and accessories.
  - The MS 201 must be installed by authorized personnel in the manner described in the operating manual.
  - During operation, you should pay attention whether there is any danger. If a hazard is detected, shut off the MS 201 immediately and notify the authorized dealer.
  - When the tire changer running, unauthorized personnel should be kept away from the machine.
  - The operator must wear protective gear such as protective gloves, safety goggles and overalls to prevent accidental injury.
  - The protective conductor must be connected correctly.
  - When the tire changer is being operated, unauthorized personnel should be kept away from the machine.
  - Failure to observe the requirements for operation or to heed the warnings related to the dangers specified in the operating manual poses the risk of injuries to the operators or personnel nearby.
  - The MS 201 must be operated by technically capable personnel. The operator must have received special training and understood the requirements in the operating manual.
  - He or she must also understand related safety requirements and the requirements for operation.
  - The operator must not operate the MS 201 after consuming alcoholic beverages.
- The operator must pay attention to the following:
    - All requirements in the operating manual must be understood.
    - The operating principle of the tire changer must be clear.
    - Unauthorized personnel should be kept away from the MS 201 during operation.
    - It is necessary to ensure that installation of the MS 201 complies with applicable local laws and regulations.
    - It must be ensured that the operators have received training and have the skill to operate the MS 201, and they must be monitored.
    - Do not detach bolts, nuts or the other components from the MS 201.
    - Do not touch the motor and live parts on the machine such as connection cables before the voltage supply has been disconnected.
    - Carefully read the operating manual and learn how to use the MS 201 correctly and safely.
    - Keep the operating manual for the future reference.
  - Do not detach the danger labels, safety warnings and operation tips on the MS 201.
  - If there is any damage, please contact the local authorized dealer promptly.
    - During the process of use and maintenance, the operator should pay attention to the danger of the high electrical voltage.
    - Do not modify the MS 201 or use anything other than original parts.
    - The operators must wear tight overalls, gloves, safety goggles, and safety shoes, etc.
    - When the operator makes operation or maintenance, it is forbidden to wear loose clothes, necklace or long hair.

## 3. Product description

### 3.1 Intended use

MS 201 is used to demount/ mount the car tire. The dimension of the rim is 9"-22". The maximum wheel diameter is 1050 mm, the maximum tire width 13". Any other use shall be construed as improper use.

! The manufacturer assumes no liability for any damage arising from operation in a manner not specified in this operating manual.

### 3.2 Machine rating plate

Each MS 201 is equipped with an identifying plate that lists the technical parameters and serial number. It is prohibited to remove the rating plate from the MS 201.

ii Each MS 201 is equipped with an identifying plate that lists the technical parameters and serial number.

Symbol	Meaning
V	Rated voltage
A	Rated current (during operation)
kW	Power
Hz	Frequency
Ph	Phase of the voltage supply
bar	Operating pressure from the compressed air supply
Serial N.	Serial number of the MS 201
CE	CE marking

ii Complete information on the model and serial number will help our technical personnel provide you with service and technical support. It will also make replacement of parts more accurate and easier. If there is difference between the data in the operating manual and the data on the rating plate, that on the rating plate should be considered correct.

### 3.3 Device description

! All information about the MS 201 must have been understood. It must be clear how

- accidents can be avoided.
- the tire changer must be operated.
- the functions and control elements can be used.

! Accidents can be prevented only if every step required for operation is understood.

! The MS 201 must be installed correctly, operated correctly and also serviced periodically.

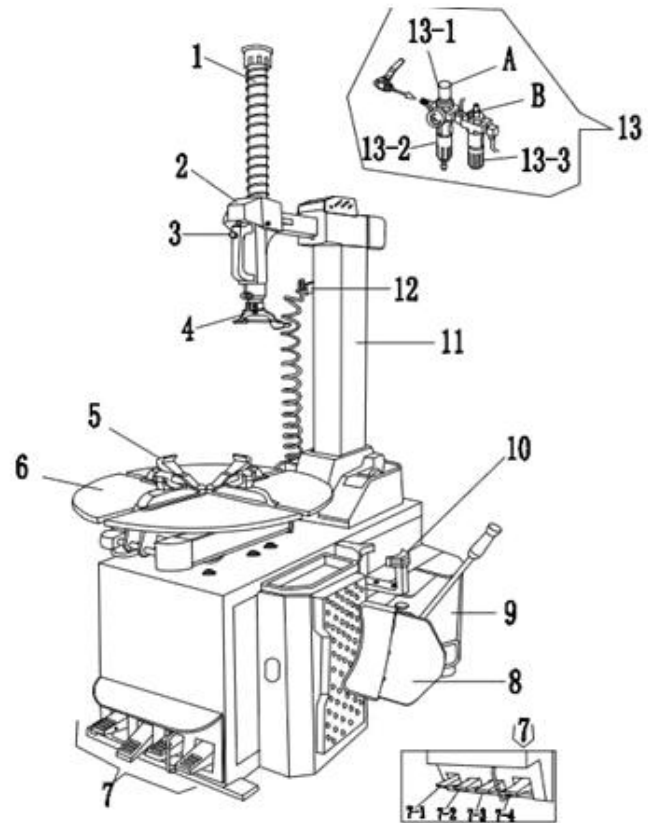

Fig. 1: Product description MS 201

- 1 Hexagon shaft: for securing the mounting head
- 2 Cover: dust prevention
- 3 Mounting arm locking valve: for locking/unlocking the mounting arm
- 4 Mounting head: the tool for demounting/mounting the tire
- 5 Clamp jaw: for clamping the rim
- 6 Turntable: for placing the wheel
- 7 Pedal control system
- 7-1 Mounting arm control pedal: controls pivoting of the mounting arm
- 7-2 Clamping jaw control pedal: control open/close of the clamping jaw
- 7-3 Blade control pedal: control the blade movement
- 7-4 Turntable rotation control pedal: control the rotation of the turntable
- 8 Bead-breaker blade: for unseating the tire from the rim
- 9-Blade arm: supports the bead breaker blade
- 10 Lubricant holder: conveniently positioned for fastening a variety of lubricant containers
- 11-Column: support horizontal arm
- 12-PCL Inflation gun: inflating for the tire
- 13-Air treatment assembly
- 13-1 Pressure-limiting valve, for regulating the supply pressure
- 13-2 Water separator
- 13-3 Atomized lubricator: provides oil for the air passages

### 3.4 Scope of delivery

Denomination	Quantity
MS 201	1
Bead breaker assembly	1
Mounting lever	1
Inflation gun with pressure gauge	1
Bead breaker cover	1
Protection cover claw	1
Mounting tool cover	1

## 4. Transport

### 4.1 Transport and packing

The MS 201 must be placed in the original packaging for transport. The package should comply with the following requirements.

The package size requirement:

Dimensions	Package size
Width	1150 mm
Length	1200 mm
Height	1050 mm

### 4.2 Transport method

- Open the top package, plug the fork of the forklift from bottom of the original package.

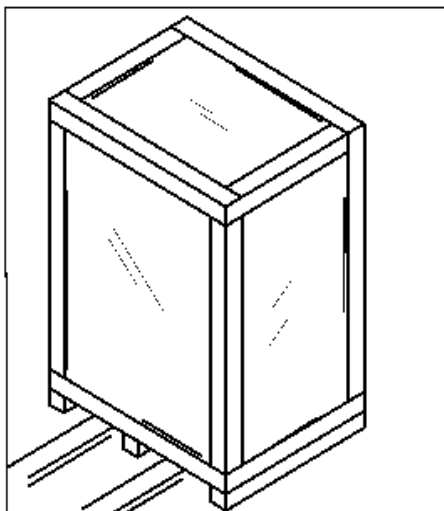

- ⓘ Keep the original package for the future transporting.

## 5. Unpacking

### 5.1 Unpacking

- When unpacking, the operator should wear the proper protective gear such as protective gloves.
- Check the delivery carefully to make sure that all parts have been delivered. If there is any mistake, please contact your authorized dealer at once.
- The objects in the carton, such as boards, nails, screws and plastic bags, should be stored in a safe location.
- If there are any environmentally harmful or non-degradable substances, you should treat them in accordance with local laws and regulations.

- ! During the process of unpacking, assembly and transporting, you should follow the following requirements and handle with care. Otherwise, the MS 201 could be damaged.

1. Detach the upper cover of the carton and make sure whether there is any damage or not during transporting.
2. Find the fastening screws holding the MS 201 on the pallet.

### 5.2 Setting up the MS 201

- ! Steps 1 - 11 must be completed on the pallet. Do not loosen the screw and secure the mounting arm until installation is complete while the MS 201 is being moved.

1. Fasten the hoisting strap (mod. DR 750, 3 m and DR 735, 1.5 m, factor 6:1).

- ! Hoisting strap requirement: more than 1 metric ton and safety factor 6:1.

2. You should use the above method whenever the MS 201 is moved.

- ! Do not move the MS 201 unless the MS 201 has been disconnected from the voltage and compressed air supplies.



3. Lift the mounting arm onto the MS 201 as shown in the figure below.

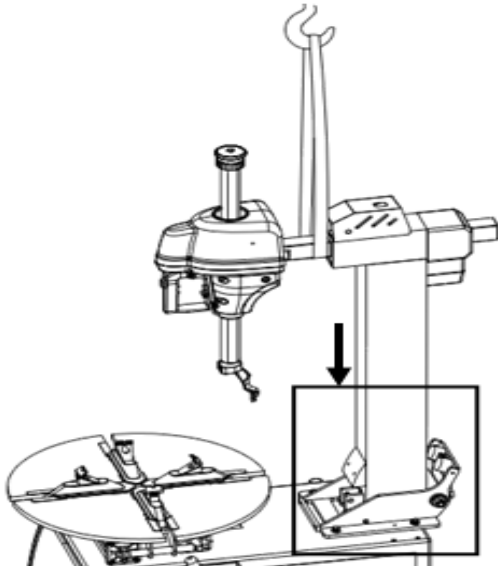

4. Put the air pipe that inside column into the machine body.

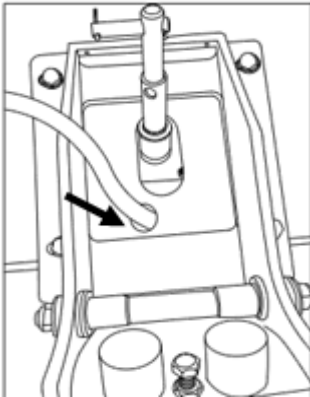

5. Position the MS 201, then drive the fixed axis insert into the corresponding holes with a hammer and fasten.

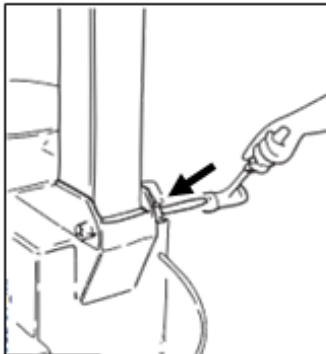

6. Connect the fixed axis insert to the bead breaker cylinder and mounting column, and then fasten.

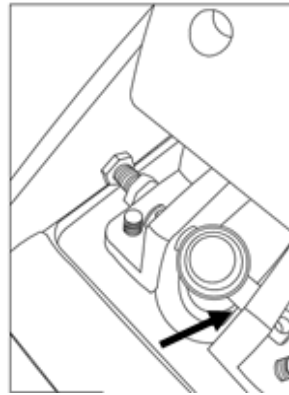

7. Before lifting the complete MS 201.

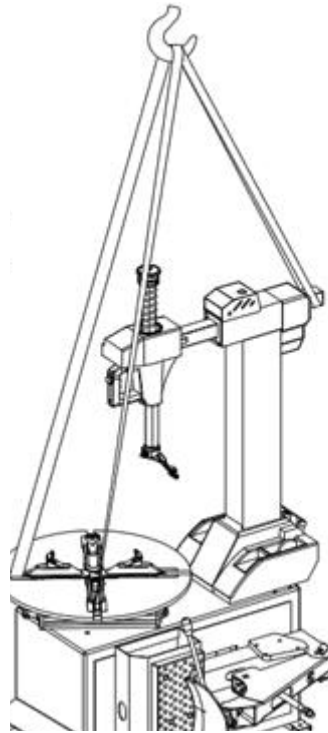

8. Affix the cover then fasten the screw.

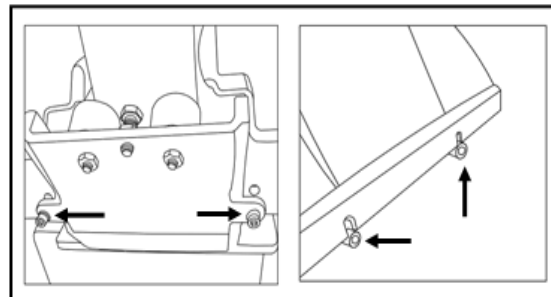

- To connect the air hose, open the side panel of machine housing, then attach the air hose to the straight connector.

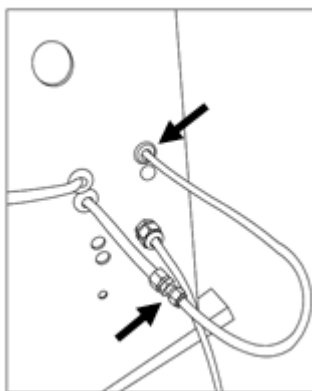

- Assemble the bead-breaker blade, then fasten the screws.

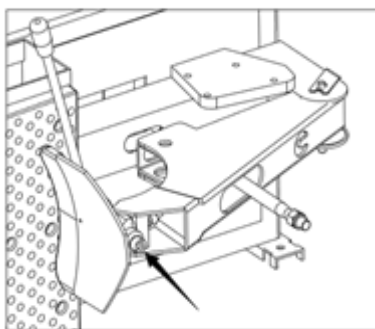

- Loosen the anchor bolt, push the mounting arm to the innermost position, and prepare the lifting device.

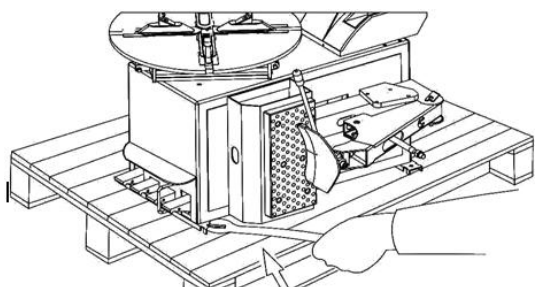

## 6. Initial commissioning

### 6.1 Initial commissioning

Installation environment requirement:

Initial commissioning	Requirement
Temperature	4 - 40 °C
Sea level	<1000 m
Humidity at 40 °C	50%
at 20 °C	90%

- When selecting the installation location, ensure that the MS 201 is safe when it is used under normal operating conditions.
- The MS 201 must be connected to the voltage supply and compressed air supply; we thus recommend that the MS 201 be set up close to these two utilities.
- Installation position should at least leave the space in the following figure to secure free movement of each part of the machine.
- If the MS 201 is installed outdoors, you should take measures to protect it from rain and sun. The MS 201 is not intended to be used outdoors.
- The work area should enjoy enough light to secure the operators can observe each details of the operation.

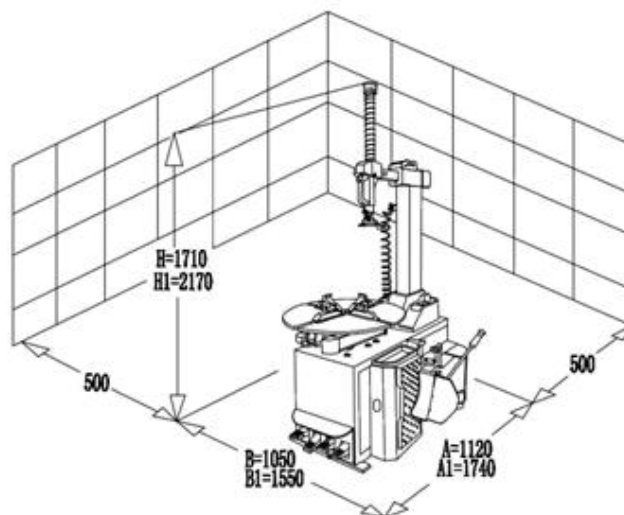

- ! Besides the operator, no other personnel should be in the work area when the machine is running.

## 6.2 Fastening the MS 201

**!** For the procedure when lifting the MS 201, please see the figure. Lift the MS 201 carefully (the middle of the MS 201 is not identical with the center of gravity) and protect the plastic covers to prevent damaging them.

1. Detach the bolts and nuts fixed on the machine chassis.
2. Bind the hoist tape (mod. DR 750 of 3 m and DR 735 of 1.5 m factor 6:1).
3. Lift the MS 201 carefully.
4. Remove the pallet and position the MS 201 at the preselected location.

**!** Ensure that the nozzle and air hose on the MS 201 are not damaged during the hoisting operation. Be very careful when lifting the MS 201.

**ii** If tires will be inflated on the turntable, you must secure the MS 201 to the floor.

5. Use an M10 bolt (grade 12.9), placed through the hole in the pallet, to secure the MS 201 to the floor.

## 6.3 Connecting the MS 201 to power and the compressed air supply

**!** In accordance with the electrical specification, the voltage supply must be equipped with a fuse and a properly grounded protective conductor connection as well as a safety switch.

**ii** If the MS 201 does not have a plug, the user should prepare a 16 A plug suitable for the operating voltage of the tire changer and as specified in the electrical code.

1. Connect the MS 201 to the voltage supply.
  - The voltage deviation should be 0.9 - 1.1 times the rated voltage range, and the frequency deviation should be 0.99 - 1.01 times the rated frequency range. You should take the necessary protective methods.
  - Only qualified personnel should make the connection to the voltage supply.
  - If the MS 201 is not being used, please disconnect the power promptly to ensure that the MS 201 is not switched on accidentally.

- If the MS 201 will not be used for a long time and the machine is connected directly to the electrical cabinet instead of via a plug, the electrical cabinet should be locked. Only professional personnel should be able to open the electrical cabinet in order to ensure that the MS 201 is not switched on unintentionally.

**!** The MS 201 must be grounded and the protective conductor must not be attached to a heater, plumbing pipe, telephone cable or the like.

2. The compressed air supply must comply with the requirements for the tire changer. The details of these requirements are specified in "Technical parameters" section. The pressure and volumetric flow of the compressed air supply should meet the requirements of the MS 201. The pressure must be between 8 and 16 bar.
  3. Use the special air hose to connect the water separator, air regulator and lubricator on the side of the MS 201 (see figure).
  4. Please make sure that the oil has been fully filled reaching the standard oil level. The oil contained in the lubricator should be SAE 20 oil, or the air passage will not be lubricated, causing the sealing kits to be damaged in a short time.
- The user must mount an air supply shut-off valve and pressure control valve in front of the MS 201.

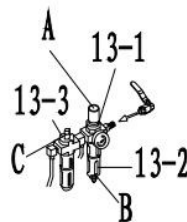

## 6.4 Checking the pedal functions

- Depress the turntable rotation control pedal 7-4; the turntable will rotate clockwise.
- And rise up the turntable rotation control pedal 7-4, the turntable will rotate counterclockwise.
- Step down the horizontal arm control pedal 7-1 to the lowest position and the horizontal arm will swing out.
- Go on to step down the horizontal arm control pedal to highest position the horizontal arm will swing back to the vertical position.
- Depress the blade control pedal 7-3; the blade executes its function.
- Release the blade control pedal 7-3 and the pedal returns to its original position.
- Step down the clamping jaw open/close control pedal 7-2 to the first gear and the clamping jaw will open.

- Depress the clamping jaws control pedal 7-2 to the second position and the clamping jaws immediately stop.
- Depress the clamping jaws control pedal 7-2 to the third position and the clamping jaws close.
- When the mounting arm is at the innermost position, it is released and tool head will drop.
- When the mounting arm is at the middle position, it is released and the tool head will move up.
- When the mounting arm is at the outermost position, the mounting arm and tool head are locked.

#### Maintenance unit

- Pressure-limiting valve 13-1: Pull out the knob on the top of the pressure-limiting valve A. Clockwise/counterclockwise turning can adjust the supply pressure to the MS 201. Press down the knob A after adjustment.
- Water separator 13-2: Clockwise/counter clockwise turning knob B at the lower end of water separator can deflate the water in the water cup.
- Lubricator 13-3: Turning the knob at the top end of the lubricator. Clockwise/counter clockwise turning can adjust the oil feeding speed of the lubricator.

#### Note

- The supply pressure should be in the range of 8-10 bar.
- Regularly vent the water in the water separator.
- Move the blade cylinder back and forward, and observe the condition of lubricator. Before operating, ensure that oil will be fed each day.

## 7. Operation

! The following information must be read, and will be helpful to the operator to simplify the steps needed for operation and reduce unnecessary trouble.

### 7.1 Safety notice

! The MS 201 is intended to be used only to mount/demount passenger car tires (see the section "Technical data").

! If an accident happens, shut off the MS 201 immediately.

- Disconnect mains plug.
- Turn off compressed air supply.

### 7.2 Check before use

1. Before operating the MS 201, always run the bead breaking cylinder back and forward while observing the lubricator to make sure it starts feeding oil to the air passage. After you confirm that the lubricator works normal, you can guarantee each part of the air route system under perfect lubrication.
2. Check the maintenance unit to ensure that the pressure indicated on the pressure gauge of the pressure-limiting valve is not less than 8 bar.
3. Check whether the power supply connection is correct.

### 7.3 Information about special rims and tires

! Special process to be need for some special tires, which different from the normal demount/ mount process.

! As shown in the figure below, some alloy rims have a very shallow rim channel in the center of the rim. Or the rim channel has no depression. These rims do not meet the safety regulations for vehicular traffic and transportation. In some countries, these types of rim/wheel are not allowed in the market.

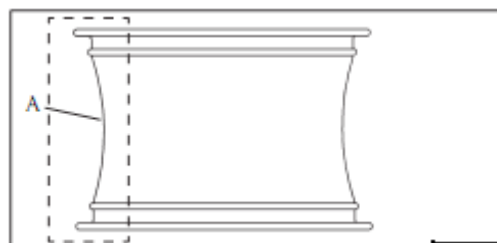

- ! Pay special attention when demounting/mounting tire that the rim or tire are not damaged.
- ! In the process of inflating the tire, there is a risk that the tire may burst.
- ! The cross-section of some rims is that shown in the figure below. The C position is very deep on these rims. B is higher than A here. When you break the bead of this type of tire, you must press the bead, since it must be lower than the B position. When mount the tire, the bead opposite to the mounting head must over B point. At this moment, the bead can be led into the groove at the middle of the rim.

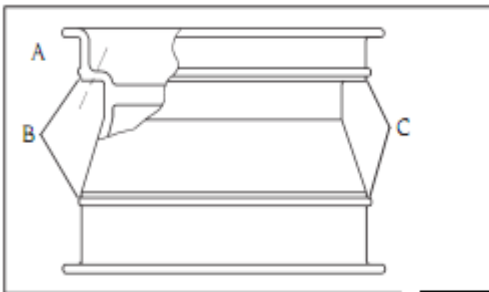

- ! Some wheels have the tire pressure inspect system as figure below. Do not damage the tire pressure monitoring system when mounting/demounting tires.

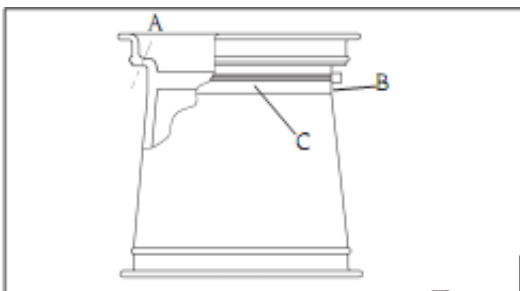

- ii To protect the rim, the mounting head plastic cover should be changed twice a month. If damaged, these plastic parts should be changed at once.

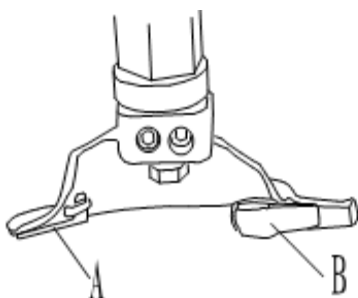

## 7.4 Unseating the tire bead

- ! Not using the grease will seriously damage the tire. Please use the special grease.
  - ! Remove all balance weights on the rim.
  - ii Before demounting and re-mounting the tire, check for signs of wear on all protective plastic parts. Replace the wheel-guard hoods if necessary.
  - ii Always establish the rim and tire data prior to removal/mounting. The method of attachment, pressure and accessories required can then be planned in advance.
1. Check whether the tire has been deflated completely. If not, you should deflate at first.



### Warning – Risk of injury from trapping hands between rim-chuck plate and tire.

As the tire moves, make sure that your hands do not get caught between the tire and rim-chuck plate.

- Before starting, turn the rim-chuck plate to a position where the rim-chuck claws are at an angle of 45° to the machine housing.



### WARNING – Risk of injury to extremities!

- Use extreme caution when operating the bead breaker arm in order to prevent limbs from being crushed between the tire and the bead breaker unit.
- Never reach between the tire and the bead breaker arm.
- The clamping jaws on the turntable should be closed completely.
- Do not open the clamping jaws while unseating the tire bead.

2. Lean the tire against the rubber wheel support.
3. The surface of the blade will stay about 1 cm away from the rim, and the blade should rest on the tire properly.

- ! Pay attention to the position of the blade to prevent it from touching the rim after bead breaking.



4. Depress the blade control pedal 7-3 to make the blade start working.
5. When the bead is broken, release the pedal at once.

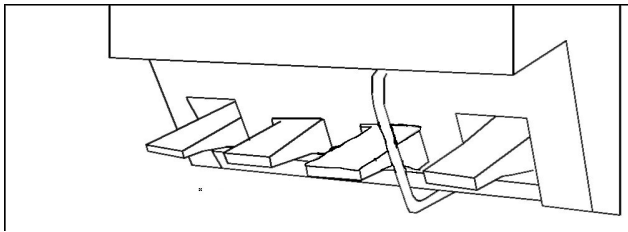
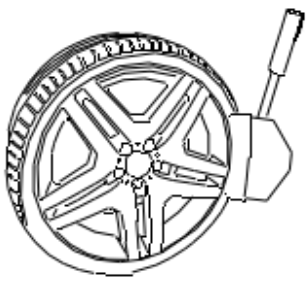

6. Rotate the tire until the edge of the tire is detached from the rim and repeat at the other side.
7. Apply lubricant to the tire.

**!** Not using the grease will seriously damage the tire. Please use the special grease.

## 7.5 Rim location direction

How to decide from which side of the wheel to demount tire?

1. When fix the wheel, the side of standard rim will upward as figure.
2. Measure three dimension of A, B and C.
3. When fix the rim, the smallest size of C must be positioned at the top position.

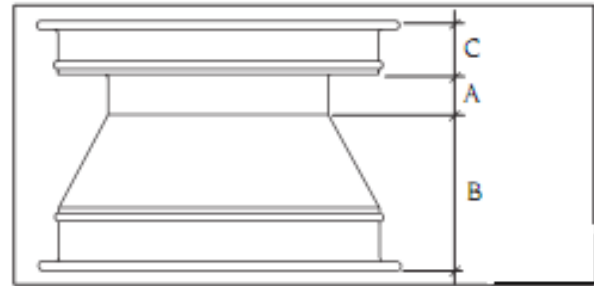

## 7.6 Clamping the rim

- ! When the mounting arm swings out, no one is allowed in the range of its movement.
- Depress pedal 7-1, swing out the mounting arm and clean the turntable.
- ! When clamping the tire, it is absolutely forbidden to put your hand under the tire. To clamp the tire correctly, you should position the tire at the very center of the turntable.
- ! One operator is enough to position the tire on the turntable if the weight is less than 25 kg. If the weight is 25 kg - 50 kg, 2 persons will be needed. You will need to use the tire lifting device if the weight exceeds 50 kg.

### 7.6.1 Clapping the rim from the outside:

1. Depress the clamping jaws control pedal 7-2 to open the clamping jaws.
2. Place the tire on the clamping jaws, while pressing down the rim.
3. Place the tire on the turntable, and depress the clamping jaws control pedal 7-2 until the rim is clamped.

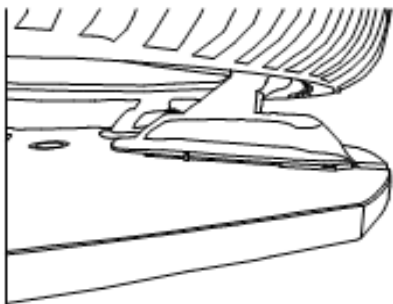

- ! Make sure the rim is clamped securely.

### 7.6.2 Clamping the rim from the inside:

1. Close the clamping jaws on the turntable.
2. Place the tire on the turntable, and then press the pedal until the rim is clamped.

- ! Make sure the rim is clamped securely.

## 7.7 Demounting the tire



### Warning: Risk of damage to the tire and rim!

Excessive contact pressure may cause internal or external tearing in the tire. The rim may become scratched or dented.

- Follow the mounting and demounting instructions of Wdk (obtainable in German and English):
  - Criteria catalog.
  - Tire overheating.
- Adjust the pressure to the type of tire.
- Use the rim guard for easily damaged rims (e.g. alloy rims).

### Additional information on mounting runflat and UHP tires.



### Warning: Risk of damage to runflat and UHP tires!

Danger of tire rupture (on the inside/outside) from working at high speed and when the tire is cold.

- Tire core temperature at least 15 °C.
- Before demounting the tire, heat it with an electric tire heater.

### 7.7.1 Positioning of the mounting head



#### Warning – Risk of hand injuries!

There is a risk of crushing hands when rotating the rim-chuck plate.

- Do not reach between the tire and the rim with your fingers.

1. Press the top bead by hand to leave the space for positioning the mounting head.
2. Depress the mounting arm control pedal to move the mounting arm to the work position.
3. Push the button on the mounting arm lock plate to release the hexagonal shaft.
4. Move the mounting head to the work position. The plastic part at the nose of the mounting head should be in contact with the rim.
5. Push the button on the mounting arm lock plate lock the hexagonal shaft.

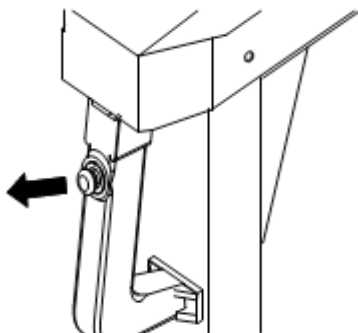
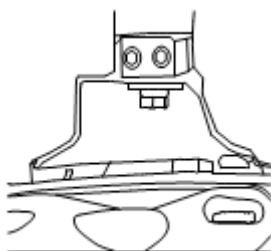

### 7.7.2 Lever the top bead over the rim flange

1. Hold the bead-lifting lever firmly while keeping space for the mounting head.

**i** If the space is not adequate, please refer to the "Operation tips" section. The tips in the "Operation tips" section will ensure successful bead breaking.

2. Check that the mounting head has grasped the tire bead fully.

**i** If there is inner tube, please turn the valve 10 cm away to the right and then proceed. This will prevent damaging the inside of the tire.

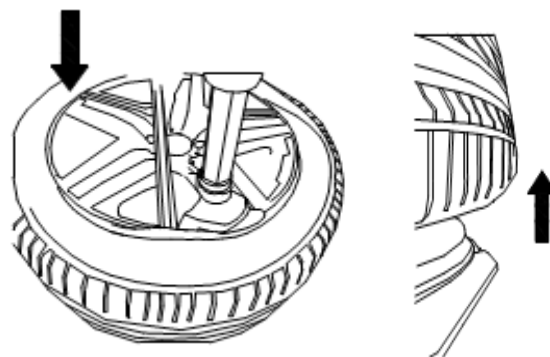

### 7.7.3 Demounting the top bead

1. Depress the pedal 7-4 and rotate the wheel until the top bead is completely detached from the rim.
2. At the same time, lifting the bottom bead can help demount the top bead.
3. If the bead slips back into the rim channel during this process, you can take the measures described in the "Operation tips" section to demount the top bead.

### 7.7.4 Demounting the bottom bead (with the aid of the mounting head)

1. If the tire has an inner tube, remove it.
2. Use the same process for the lower tire bead until the tire is demounted successfully.
3. Lever the tire over the upper rim flange with the aid of the bead-lifting lever.
4. Depress the pedal 7-4, and rotate the wheel until it is fully detached from the rim.

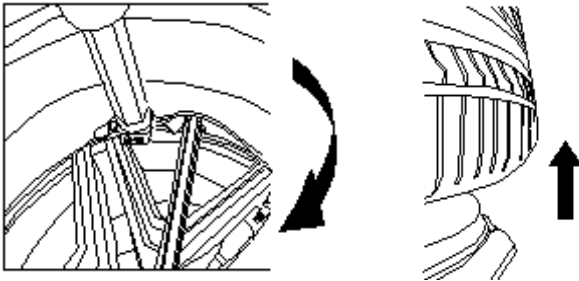

### 7.7.5 Removing wheels

1. Swing the mounting arm to the back.
2. Remove the tire.

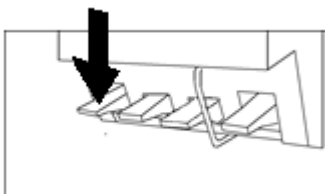
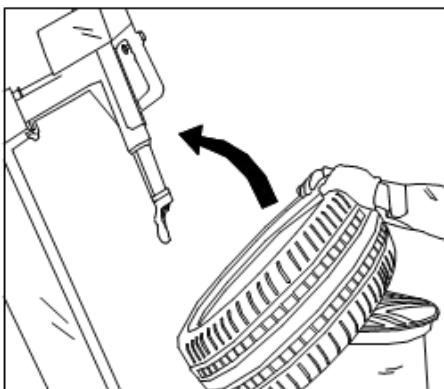

## 7.8 Mounting the tire



### Risk of accident from damaged rims and tires!

If the tire or rim is damaged during mounting, this may lead to dangerous or life-threatening situations when driving.

- The tire must be mounted by trained persons only.
- Follow the mounting and demounting instructions of Wdk (obtainable in German and English):
  - Criteria catalog.
  - Tire overheating.
- Do not subject tires and rims to excessive force.
- Set a low speed of rotation when mounting tires on critical wheels.
- Use a sufficient amount of lubricant.
- Stop the fitting process immediately in the event of any anomalies, such as abnormal noise.

### Additional information on mounting runflat and UHP tires.



### Warning: Risk of damage to runflat and UHP tires!

Danger of tire rupture (on the inside/outside) from working at high speed and when the tire is cold.

- Tire core temperature at least 15 °C.
- Before demounting the tire, heat it with an electric tire heater.



Remove all of the balance weights from the wheel rim.

### 7.8.1 Selecting the tire

**!** Before selecting the tire, you should know all of its technical features, technical parameters, characteristics and the safety grade of the tire. The related information is marked on the sidewall of the tire.

- i** Before mounting the tire, please change the valve insert to an insert for a tubeless tire.
- Confirm whether the tire parameters match the parameters of the rim. Also make sure that the rim is not deformed and the center hole is not damaged. At the same time, ensure that the surface of the rim has no rust or cracks and that there are no burrs at the nozzle.
  - Confirm that the tire is in perfect condition and without any damage.

### 7.8.2 Preparing the tire

1. Lubricate the bead with the special tire grease.
2. Place the tire on the rim at a tilt angle of 45 degrees.

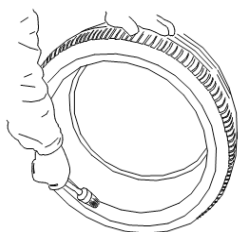

### 7.8.3 Positioning of the mounting head

- Depress the pedal pedal 7-1 to move the mounting head to the initial work position.

**i** If the rim has not been changed, the mounting head will automatically return to the correct working position.

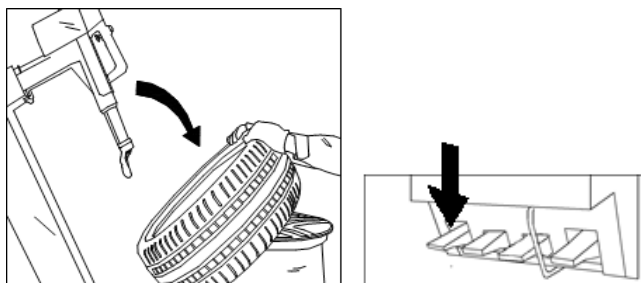

### 7.8.4 Mounting the lower tire bead

1. Simultaneously place the bottom bead under the nose of the mounting head and on the end of the mounting head.
2. Use your hand to press the tire slightly to guide the tire into the rim channel.
3. Rotate the turntable clockwise to mount bottom bead.

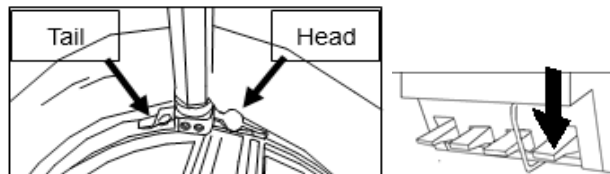

### 7.8.5 Mounting the top bead



#### Warning – Risk of hand injuries!

Your hand may be crushed if it is between the rim and the mounting head when the hexagon shaft returns to its work position.

- Do not reach between the tire and the rim with your fingers.
- Do not place your hand on the tire.
- Remove all objects that may endanger operators, e. g. bracelets and loose clothing, etc.
- Keep your hands and the other parts of your body away from the mounting head as far as possible.

1. Simultaneously place the top bead under the nose of the mounting head and on the end of the mounting head.
2. Press the tire bead and guide it into slot in the steel hook.

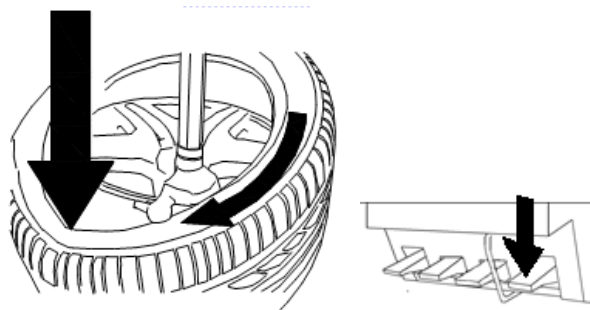

**!** Now, the tire bead cannot slide out of the mounting head.

**i** When mounting/demounting tires, the tire rotates clockwise. If the tire jams during the process, please stop working and rotate the tire counterclockwise to release the jam.



## 7.9 Procedure for mounting/demounting alloy rims

 On some alloy rims, the rim channel at the middle of the rim is very shallow or there is no rim channel. The figure below shows this:



 The demounting process for the wheel and demounting the top tire bead differ, since the hook cannot catch a suitable position. Depending on the situation, the operator needs to find best position, i. e. where the resistance for the wheel is the lowest.

## 8. Inflation





Inflation can lead to hazardous situations.

The user must undertake the necessary precautions to ensure safety.

- Wear hearing protection.
- Wear safety goggles.
- To protect the user from potential danger during inflation, only inflate the tire to a maximum 3.5 bar while the tire is on the rim-chuck plate.
- Avoid any distractions while inflating. Constantly observe the tire inflation pressure on the pressure gauge to avoid over-inflation.
- When inflating, avoid all distractions.

 During operation, the noise may reach 85 dB(A), for this reason, the operator must wear the appropriate protective gear.

 The MS 201 is equipped with a pressure-limiting valve, but if the condition of tire and rim is not good or the operation is performed incorrect, there is still the possibility of the tire bursting.

 Do not exceed the maximum pressure specified by the manufacturer.

During the inflation process, the operator should keep away from the tire as far as possible.

- Carefully check if the size of the rim is same to the size of the tire.
- Check the wear state of the tire or whether there is damage or not.
- During the inflation process, frequently check the pressure inside the tire.
- The max. inflation pressure is 3.5 bar, do not exceed manufacturer's recommended pressure under any circumstances.
- Keep hands and body away from the tire.

## 8.1 Inflating tubeless tires

1. Ensure that the rim is held securely on the turntable and that the mounting head and tire pressing disk are not in contact with the tire. If possible, they should be positioned to the farthest point.
2. Install a new valve in the rim.
3. Make sure that the entire tire has been lubricated.
4. Remove the cap from the valve and place the inflation gun on the top of the insert to inflate the tire.
5. Interrupt the inflation process occasionally and check the pressure in the tire until the specified value is reached. Do not exceed the max. pressure. The pressure must not be greater than 3.5 bar under any circumstances.

 Tubeless tires need a relatively high volumetric flow of air. If air flow is inadequate, the bead will not pass over the hump. To increase the air flow, you can take out the valve insert.

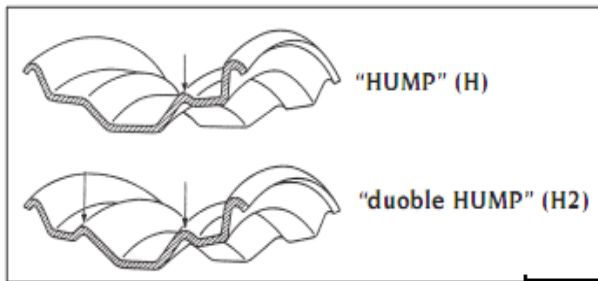

6. Check the connection between the tire bead and rim.

 The connection between the tire bead and rim must be perfect. If there is problem, you must deflate the tire, unseat the tire bead again and relubricate the tire bead. Rotate the tire on the rim and then inflate once again.

7. Screw in the valve insert.
8. Connect the inflation gun and then press the deflate button to remove the residual air.
9. Attach the valve cap.

## 8.2 Inflating tubed tires

1. Ensure that the rim is held securely on the turntable and that the mounting head and tire pressing disk are not in contact with the tire.
-  If possible, they should be positioned to the farthest point.
2. Make sure that the entire tire has been lubricated
  3. Remove the valve, place the inflation gun head on the head of the air valve and depress the inflation pedal to inflate the tire.
  4. Push the valve on the tube to release the air between the tube and tire. Otherwise, the tube will be damaged.
  5. Interrupt the inflation process occasionally and check the pressure in the tire until the specified value is reached. Do not exceed the max. pressure. The pressure must not be greater than 3.5 bar under any circumstances.
  6. Screw in the valve insert.
  7. Connect the inflation gun and then press the deflate button to remove the residual air.
  8. Attach the valve cap.

## 9. Maintenance

### 9.1 Warning

- ! Non-professional personnel should not perform maintenance.
  - ! Before performing any maintenance, you should switch off the air supply and power. By repeatedly depressing the pedal, you can release the residual air in the machine completely.
  - ! Perform maintenance periodically as described in this operating manual. This is necessary to prolong the life of the MS 201 and guarantee normal operating conditions.
  - ! If maintenance is not performed periodically, the reliability and proper operation of the MS 201 are no longer guaranteed, and the MS 201 can be damaged. Operators and persons nearby can be injured.
  - ! Defective parts must be replaced with original parts provided by the manufacturer.
  - ! Removing or breaking safety devices such as the safety valve and standard nozzles violate the safety standards.
  - ! You should not modify components on the machine without authorization.
- ii** Special note: The manufacture will not honor claims arising from the use of parts provided by other suppliers and for damage caused by removing or breaking the safety devices.
- Keep the working area clean.
  - Do not use compressed air to remove dirt from the MS 201.
  - Keep generation of dust in the area to a minimum.

### 9.2 Maintenance operations

#### 9.2.1 Maintenance unit and bead breaking cylinder

- ! Perform the following operation at least once every 30 days.
1. Check the oil level in the oil cup. If there is not enough oil, remove the oil cup and replenish the lubrication oil as shown in following figure. The oil filled into the lubricator must be the special SAE 20 oil.
  2. Oil feeding speed regulation: Move the bead breaking cylinder back and forward to check whether the oil feeding speed is one drop of oil per 2 stokes of the cylinder. If not, use the bolt B to adjust as shown in following figure.
  3. Drainage: Check the water quantity in the water cup. Turn/press the valve at the low end of the water cup to drain.
  4. Before operating, always run the bead breaking cylinder back and forward while observing the lubricator to make sure it starts feeding oil to the air passage. After you confirm that the lubricator works normal, you can guarantee each part of the air route system under perfect lubrication.

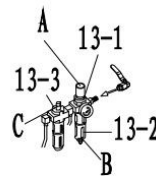

5. Periodically tighten the nut at the fixed equipment.
6. Periodically fill in the lubrication oil components can move and slide to each other.

### 9.2.2 Belt

 Periodically adjust the tension of the motor belt as per the following steps:

1. Before this operation, switch off the power supply and air supply.
2. Detach the side panel on the machine cabinet.
3. Release the bolt A and nut C. Adjust the bolt B at the back end of the motor bracket. Tighten the belt as shown in figure below. The requirement to the tension of the belt is that the belt will move inward by 8 mm if you apply the force of 8 kg.
4. After adjust, position the belt and tighten bolt A and tighten nut C.

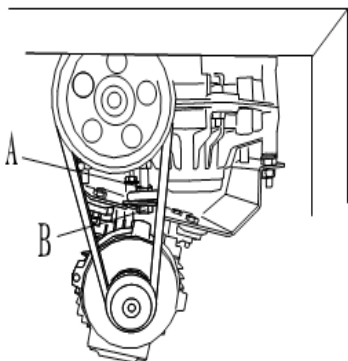

5. If the mounting head is not locked or not located at the position 2-3 mm higher than the rim, it is necessary to adjust the adjusting nuts A and B at the front end of hexangular shaft lock plate.
6. If the mounting head is not locked or not backward by 2-3 mm, it is necessary to adjust the adjusting nuts A and B at the front end of quartet lock plate.

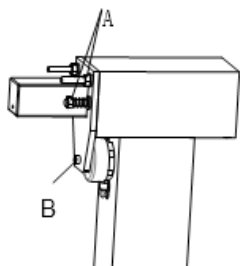
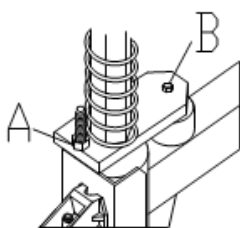

 If the lifting device moves too slow and the column tilts too slow, you should operate as per the following steps shown in figure below. Clean the silencer.

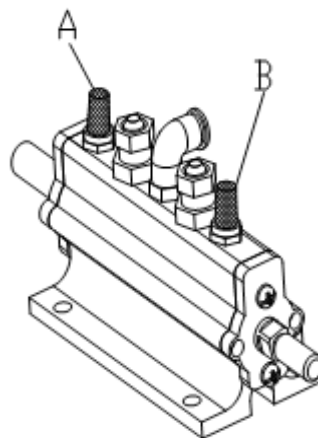

- Before any operation, switch air supply and power supply.
- Detach the side panel on the machine cabinet.
- Adjust the silencer A and B on the adjust valve assembly.
- Or use the high pressure air to clean.
- Change the silencer if it is damaged.

## 10. Troubleshooting

Faults affecting operation of the machine may occur in the course of normal working MS 201. The following table lists possible faults not requiring expert attention.

 To take action as quickly as possible it is important to quote the details on the rating plate (label on back of MS 201) and the nature of the problem when calling.

 Work on the electrical, hydraulic and pneumatic system must be performed only by appropriately qualified personnel.

 Consult customer service if the problem persists.

Problem	Cause	Solution
Turntable cannot rotate	Short circuit	<ul style="list-style-type: none"> <li>• Check cable of motor,</li> <li>• Change the motor,</li> <li>• Check the plug,</li> <li>• Check the reversing switch/change reversing switch,</li> <li>• Check the moving parts of the reversing switch,</li> <li>• Adjust the belt/ change the belt.</li> </ul>
The pedal can not back to its original position	The spring is damaged	Change the spring
Bead blade can not separate the tire edge	The cylinder sealing kits is worn	<ul style="list-style-type: none"> <li>• Change the sealing kits;</li> <li>• Change the new cylinder.</li> </ul>
Air leakage at the center of the cylinder	The cylinder sealing kits is worn	<ul style="list-style-type: none"> <li>• Change the sealing kits;</li> <li>• Change the cylinder.</li> </ul>
Worm case can not work or the noise is too much	The worm case assembly is damaged	Change the worm case.
The turntable can not fix the rim	The turntable cylinder is damaged	<ul style="list-style-type: none"> <li>• Change the turntable cylinder;</li> <li>• Change the turntable cylinder sealing kit.</li> </ul>
The torque is not enough when demount/ mount the tire	The tensile force of the belt is not enough and the bead can not be led into the groove of the rim.	<ul style="list-style-type: none"> <li>• Adjust the belt;</li> <li>• Change the motor capacitor;</li> <li>• Change the motor,</li> <li>• Use the tire pressing help to lead the tire into the groove of the rim while keep full lubrication on the bead.</li> </ul>
When lock the mounting head, the distance between the mounting head and the rim should not be too far or too near	Lock plate releases for the bad adjustment	<ul style="list-style-type: none"> <li>• Adjust the lock plate bolt at the back end of the hexangular shaft;</li> <li>• Adjust the lock plate bolt at the back end of the horizontal arm.</li> </ul>
The vertical movement of the hexagon shaft is not smooth	The lock plate does not work	<ul style="list-style-type: none"> <li>• Change the lock plate,</li> <li>• The screw in the lock plate is loose,</li> <li>• Adjust the lock plate for the hexagonal shaft.</li> </ul>
The mounting head can not lock for the mounting head move too much in the process of demount/mount tire and the rim is easy to be damaged	Lock cylinder is damaged, there is wear at the sliding position of horizontal/ vertical arm and without air to flow in	<ul style="list-style-type: none"> <li>• Change the lock cylinder sealing part;</li> <li>• Change the lock cylinder;</li> <li>• Adjust the bolt at the lower part of the horizontal arm, making the clearance between the horizontal arm bushing and hexangular shaft narrower;</li> <li>• Adjust the bolt at the front end of the vertical arm, making the clearance between the horizontal arm bushing and quartet shaft narrower;</li> <li>• Adjust the lock plate.</li> </ul>
The vertical arm can not swing out or too slow	Vertical arm control air route with problem	<ul style="list-style-type: none"> <li>• Change vertical arm cylinder sealing kits;</li> <li>• Change vertical arm cylinder;</li> <li>• Check whether there is a kink in the air hose;</li> <li>• Check whether there is air leakage at the vertical arm tilt back control pedal valve;</li> <li>• Change the pedal valve;</li> <li>• Adjust the air flow at the nozzle on the adjusting valve.</li> </ul>
Mounting head cylinder air leakage/ hook has no force	The cylinder piston is damaged/ sealing kits is broken	<ul style="list-style-type: none"> <li>• Change the cylinder piston;</li> <li>• Change the sealing kits of the cylinder;</li> <li>• Change the cylinder.</li> </ul>



## 11. Decommissioning

### 11.1 Change of location

1. Disconnect the electrical connection.
2. Disconnect the compressed air connection.
3. Comply with the instructions concerning initial commissioning.
4. MS 201 must be fastened on the pallet with the provided bolts.

 For sale or transfer of ownership of the MS 201 all documents included in the scope of delivery, together with the MS 201 must be transferred to the new owner.

### 11.2 Temporary shutdown

Always unplug the mains connector from the socket if the MS 201 is to be temporarily shut down or if it is not being used for some other reason. It is advisable to thoroughly clean the MS 201 as well as the corresponding tools and accessories and to provide protection (e.g. by applying a thin film of oil).

### 11.3 Disposal and scrapping

#### 11.3.1 Substances hazardous to water

 Oils and greases as well as refuse containing oil and grease (e.g. filters) represent a hazard to water.

1. Substances hazardous to water must not be allowed to enter the sewage system.
2. Substances hazardous to water must be disposed of in accordance with the applicable regulations.

#### 11.3.2 MS 201 and accessories

1. Disconnect the MS 201 from the mains and detach the power cord.
2. Dismantle the MS 201 and sort out and dispose of the different materials in accordance with the applicable regulations.



MS 201, accessories and packaging should be sorted for environmental-friendly recycling.

- Do not dispose MS 201 into household waste.

#### Only for EC countries:



**The MS 201 is subject to the European directive 2012/19/EC (WEEE).**

Dispose of used electrical and electronic devices, including cables, accessories and batteries, separately from household waste.

- Make use of the local return and collection systems for disposal.
- Proper disposal of MS 201 prevents environmental pollution and possible health hazards.

## 12. Technical Parameter

### 12.1 Dimensions for

Function	Dimensions
Length	A=1120 mm
Max. length	A1=1740 mm
Width	B=1050 mm
Max. width during operation process	B1=1550 mm
Min. height	H=1710 mm
Max. height	H1=2170 mm

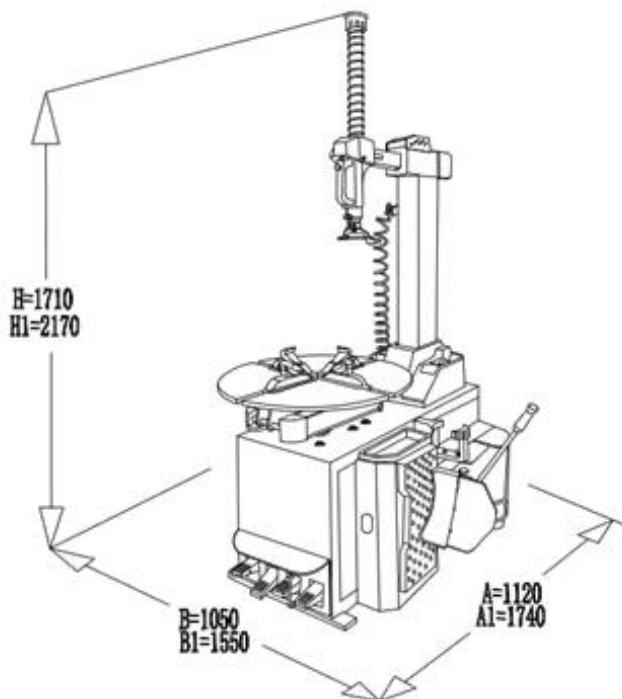

### 12.2 Range of application

! The MS 201 is intended for the following range of wheels:

Function	Range of wheels
Outside clamp	9"~20"
Inside clamp	11"~22"
Max. tire diameter	1050 mm
Max. tire width	13"

### 12.3 Turntable type

Function	Turntable type
Type of positioning	Jaw
Fix style	Jaw
Clamping style	Pneumatic
Drive style	Motor
Torque	1100 Nm
Turntable rotation speed	6 rpm

### 12.4 Bead breaker blade

Function	Decompression system
Fix style	Manual
Enter style	Manual
Max. working size	340 mm
Bead breaker blade pressure	2500 kg

### 12.5 Power

Function	Power
Single phase	220 V/110 V - 1.1 kW 50 Hz/60 Hz
Three phase	380 V - 0.75 kW 50 Hz
Air supply pressure	8-10 bar
Noise	< 70 dB

### 12.6 Pneumatic diagram

