

ENGLISH.....5

SUMMARY

REVISION OF THE MANUAL.....	5
INTRODUCTION.....	6
1 SPECIFIC SAFETY RULES FOR USING THE ACKF01 FLUSHING KIT	7
1.1 Glossary.....	7
1.2 General Rules.....	7
1.3 Operator Safety.....	7
1.4 Safety Devices.....	7
2 INTRODUCTION TO CLEANING WITH A REFRIGERANT	9
2.1 What the cleaning is.....	9
2.2 Why the Cleaning is Important.....	9
2.3 When must you clean the A/C system?.....	10
2.4 Examples of System Contaminations.....	10
2.5 Components that are Sensitive to Contaminations.....	12
3 DESCRIPTION.....	15
3.1 Intended Use.....	15
3.2 Contents of the Kit.....	16
4 TECHNICAL FEATURES.....	18
5 INSTALLATION.....	19
6 PREPARING THE CHARGING STATION.....	21
6.1 Examples of Adapters and Couplers for the Cleaning.....	23
7 PREPARING THE A/C SYSTEM.....	25
7.1 Systems with the "Block" Type Expansion Valve.....	26
7.2 System with the Thermostatic Expansion Valve (TXV).....	28
7.3 System with an Orifice Tube.....	30
8 KONFORT - A/C SYSTEM CONNECTION.....	32
8.1 Cleaning of Systems with an Expansion Valve.....	32
8.2 Cleaning of Systems with a Orifice Tube.....	40
9 FLUSHING.....	52
9.1 Alarm Notifications.....	64

10	POST-CLEANING RECOMMENDATIONS.....	66
11	MAINTENANCE.....	67
11.1	Replacing the Dryer Filter of the Cleaning Vessel.....	67
11.2	Internal Cleaning of the Cleaning Vessel.....	68
12	ENVIRONMENTAL INFORMATION.....	69
13	LEGAL NOTICES.....	70

ACKF01 FLUSHING KIT INSTALLATION AND USER MANUAL

REVISION OF THE MANUAL

This document is **revision 01** of the **ACKF01 flushing kit installation and user manual**.

Issue date: 22/06/2018

INTRODUCTION

Dear Customer,

We would like to thank you for choosing a TEXA product for your workshop.

We are certain that you will get the greatest satisfaction from it and receive a great deal of help in your work.

Please read through the instructions in this manual carefully and keep it for future reference.

Reading and understanding the following manual will help you to avoid damage or personal injury caused by improper use of the product.

TEXA S.p.A reserves the right to make any changes deemed necessary to improve the manual for any technical or marketing requirement; the company may do so at any time without prior notice.

This product is intended to be used exclusively by technicians specialised in the Automotive industry. Reading and understanding the information in this manual cannot replace adequate specialised training in this field.

The sole purpose of the manual is to illustrate the functioning of the product sold. It is not intended to offer technical training of any kind and technicians will therefore carry out any interventions under their own responsibility and will be accountable for any damage or personal injury caused by negligence, carelessness, or inexperience, regardless of the fact that a TEXA S.p.A. tool has been used following the information contained in this manual.

Any additions to this manual, useful in describing the new versions of the program and the new functions associated to it, may be sent to you through our TEXA technical bulletin service.

This manual is to be considered an essential part of the product to which it refers. If it is resold, the original buyer is therefore required to forward the manual to the new owner.

Reproduction, partial or whole, of this manual in any form without written authorisation by the manufacturer is strictly forbidden.

The original manual was written in Italian, every other language is a translation of the original manual.

© **copyright and database rights 2015.** The material contained in this document is protected by the copyright and database rights. All rights reserved according to Law and international agreements.

1 SPECIFIC SAFETY RULES FOR USING THE ACKF01 FLUSHING KIT

The technology used for the design and the production inspection of the **ACKF01 FLUSHING KIT** for charging stations makes it a simple and reliable product and safe to use.

The personnel in charge of using the charging stations is required to follow the general safety rules and to use the **ACKF01 FLUSHING KIT** for its intended use only. Furthermore, they are required to carry out the maintenance as described in this manual.

1.1 Glossary

- **Flushing:** *internal cleaning of an A/C system using a liquid refrigerant.*

1.2 General Rules

- *The operator must have basic knowledge of refrigeration, of the refrigeration system, of refrigerants and of the potential hazards that equipment under extreme pressure can cause.*
- *The operator must have read and understood the information and the instructions indicated in the technical documentation supplied with the kit.*
- *The product must be used only on the charging stations it is intended for.*
- *All the cleaning preparation operations, related to both the charging station and the vehicle, must be carried out with the power disconnected / engine off.*
- *Follow the indications and the safety rules indicated in the charging station's technical manual.*

1.3 Operator Safety

The refrigerant fluids can cause blindness and other physical injuries.

Due to their low boiling temperature (approximately - 30 °C), the refrigerants can cause cold burns when they come into contact with the skin.

Safety Measures:

- *The operator must avoid inhaling the vapours of the refrigerant fluids, using appropriate safety devices when needed.*
- *The operator is required to wear adequate safety glasses and gloves, that prevent direct contact with the refrigerants.*

1.4 Safety Devices

The **ACKF01 FLUSHING KIT** is equipped with an **overpressure valve** that intervenes when the maximum pressure value is reached.



Do not tamper with the overpressure valve in any way.



Never get close to the overpressure valve when it is open, as it could discharge pressurised refrigerant.



The maintenance operations on the safety devices must be performed by authorised Assistance Services only.

2 INTRODUCTION TO CLEANING WITH A REFRIGERANT

2.1 What the cleaning is

The cleaning with a refrigerant is an operation that is performed in order to remove the solid contaminants and the traces of old lubricant from the A/C system's compressor.

The use of liquid refrigerants avoids the risk of damaging the internal components with harsh detergents.

After emptying the A/C system, most of the solid contaminants remain attached to the lubricant that is in the system's circuits and components.

The use of the refrigerant allows you to wash away the oil and the melted solid contaminants.

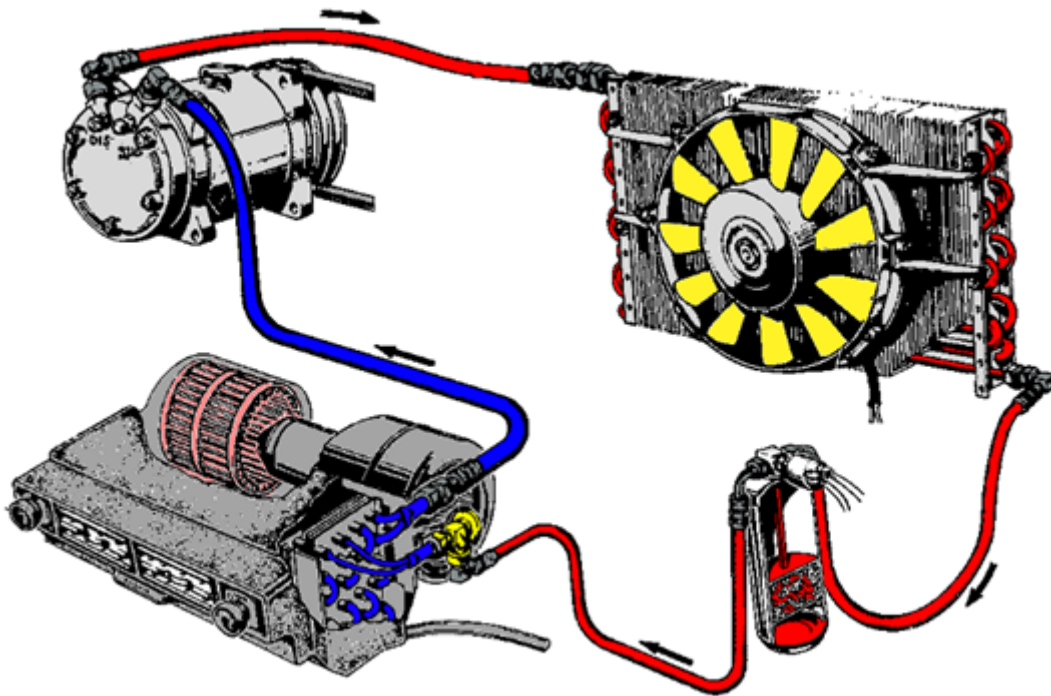

2.2 Why the Cleaning is Important

In order to guarantee its operation, the expected life of its components and its cooling efficiency, it is extremely important to keep the A/C system clean.

Even the smallest contamination particles can cause constrictions and inconveniences that will compromise the entire system.

According to the manufacturers and the reconditioners of A/C system components, the cleaning is essential for the purposes of the warranty.

In most cases, if the system is not cleaned, this determines the loss of the warranty on the components.

After a first fault within the components (for example in the compressor), the system is to be considered as contaminated.

If the system is not cleaned properly, the spare parts (reconditioned or new) will have the same fate.

Regardless of the defect detected in the A/C system, when you carry out a proper cleaning, it will be as clean (on the inside) as it was originally and thus perfectly efficient.

The cleaning restores the correct refrigerant flow and, most importantly, the oil flow, guaranteeing a longer life for the entire system.

2.3 When must you clean the A/C system?

The reasons that make cleaning the A/C system necessary are multiple.

Below is a summary of the main reasons to perform a cleaning:

- *the A/C system is dirty or the A/C circuits are contaminated;*
- *there is a leak in the system, which may have caused humidity;*
- *the refrigerant circuits remained open for a long period of time (ex. after an accident);*
- *the system has humidity caused by an improper maintenance or by the saturation of the dryer filter;*
- *there is a doubt regarding the amount of lubricant and of UV additive in the system;*
- *the compressor must be replaced due to internal damages;*
- *it is provided for by the vehicle's manufacturer.*

2.4 Examples of System Contaminations

Typically, the contamination of the A/C system is revealed through:

- *dark oil colouring;*
- *foreign bodies or residues, such as metal filings;*
- *corroded aluminium (usually in the form of white dust);*
- *presence of pieces of rider bands from the compressor's pistons or of O-rings.*

Possible leaks in the system or in the input filter of the pipe with a calibrated hole must be considered as contaminations, therefore the system must be cleaned.

Dark lubricant	<p>The presence of dark lubricant is generally a sign of a defect on the rider band of the compressor's piston.</p> <p>The premature wear of the compressor piston's rider bands, generally black in Teflon, makes the system's oil dark.</p>
-----------------------	---

Metal particles	The presence of metal particles is a sign that the compressor is worn.
Black particles	The presence of black particles is a sign of the beginning of an excessive wear of the rider bands on the pistons. The small black particles accumulate on the input of the orifice tube.
White dust	The presence of white dust is a sign of corroded aluminium. The A/C system suffers due to excessive humidity contamination. The humidity mixed with the refrigerant form toxic acids that corrode the aluminium components. You must search for leaks in the heat exchangers (condenser and evaporator) as they are the most thin metal components, generally the first ones to start leaking.
Rubber particles	The presence of rubber particles is a sign of severe contamination and of an improper maintenance of the A/C system. The O-rings deteriorate easily and break when unapproved additives, solvents or chemical sealants are used in the system.



Clean system oil



Contaminated system oil



Contamination
Deposit in the system's oil

2.5 Components that are Sensitive to Contaminations

Tube with Fixed Orifice

When working on an orifice tube, always remove the tube and inspect it.

The input filter supplies the best indication regarding possible contamination in the A/C system.

Do not try to clean it.

Always replace it if there are traces of residues or contamination.



Flexible Pipes and Rigid Pipes

The constrictions and the couplers of the flexible and rigid pipes are sensitive spots that may hold contaminations and get clogged up.



"Block" Type Expansion Valve

The "block" type expansion valves must not be cleaned.

If you suspect there is a constriction, replace them.

Generally, this type of valve does not include an input protection filter.

If you suspect there is a constriction in the valve, replace it.

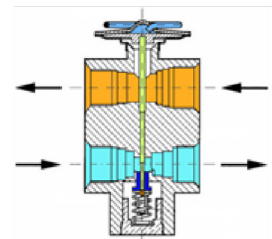

Thermostatic Expansion Valves (TXV)

The thermostatic expansion valves may include an input filter.

Generally, these filters are conical and installed at the input of the valves.

The filters can be removed and cleaned, although it is not possible to wash the valve itself.

If you suspect there is a constriction in the valve, replace it.

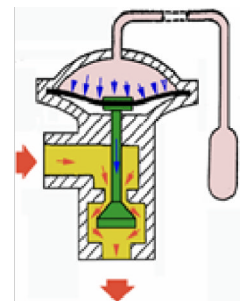

Condensers and Evaporators

These components are sensitive to constrictions caused by contamination, particularly the **Multipass** type have very small and multiple openings in which the refrigerant flows.

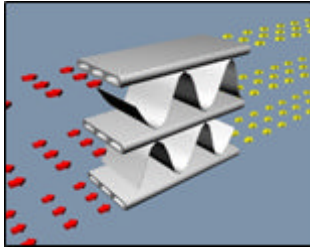

If some of these openings get clogged up, it is almost impossible to clean them and the only solution is to replace the entire component.

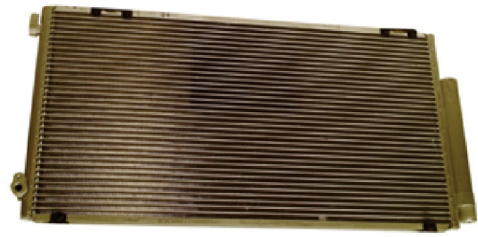

Condenser

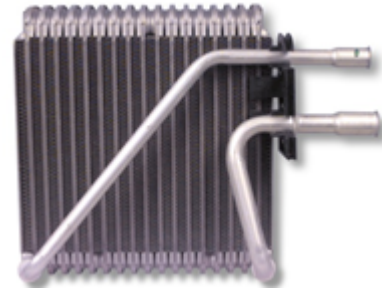

Evaporator

Dryer Filters and Accumulators

Both the dryer filters and the accumulators include fine-mesh filters and absorbent materials.

The refrigerant flow that passes through these components does not follow straight path, therefore it is impossible to carry out the cleaning.

These components must always be replaced.

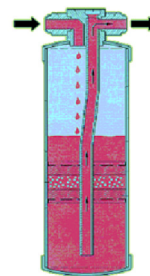

Dryer Filter

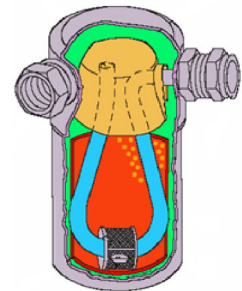

Accumulator

Compressors

The A/C system contains oil that is transported by the refrigerant in order to lubricate the compressor (as in the two-stroke engines); this means that the compressors are affected by the quality and cleanliness of the lubricant.

Contaminated oil does not supply the requested lubrication due to dirt particles that act as abrasive paper and damage the moving components.

Contamination by solid particles always causes faults in the compressor.

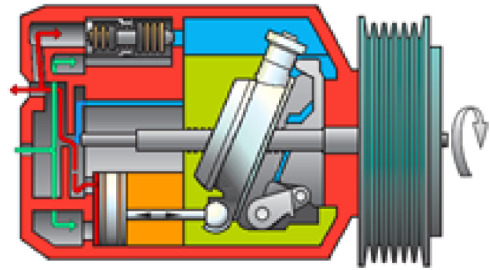

3 DESCRIPTION

3.1 Intended Use

ACKF01 is an optional kit to install on the KONFORT charging stations Series 700R, in particular on the following models:

- 710R
- 720R
- 760R
- 760R BUS
- 780R BI-GAS
- 770S

The **ACKF01 FLUSHING KIT** requires many components (which are provided with it) and the activation of the cleaning function by the software of the charging stations listed above.

The kit uses the R134a liquid refrigerant, contained in the A/C system maintenance station's tank, as a cleaning agent to remove, when possible, the lubricant, the UV dye and the residues melted by the A/C system.

The **ACKF01 FLUSHING KIT** is suitable for use on vehicles for private use, vans, truck cabs.



The ACKF01 FLUSHING KIT is not suitable for use on buses or industrial A/C systems.

3.2 Contents of the Kit

The images that follow show the contents of the **ACKF01 FLUSHING KIT**.



Item	Description	Quantity	Part code
1	Cleaning vessel	1	74350486
2	Universal adapter set for the cleaning	1	3134
3	Red service pipe for the cleaning: 3/8" x 3/8", 3000 mm	1	3900171

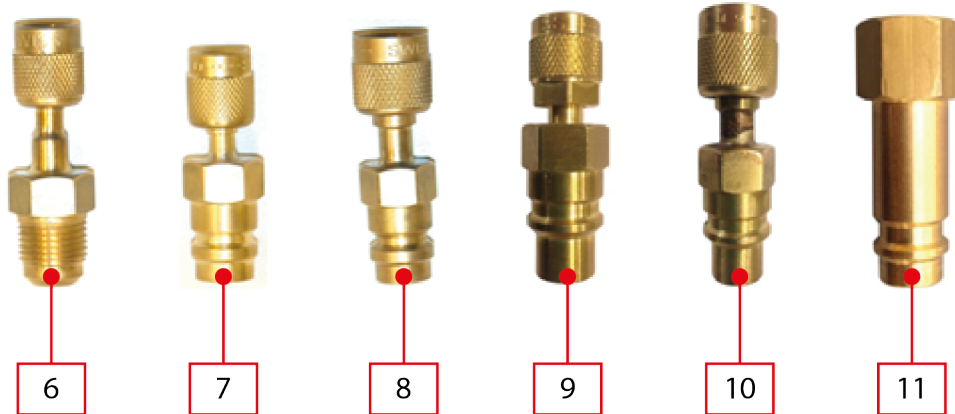
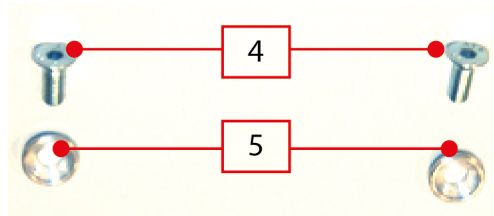

Item	Description	Quantity	Part code
4	6 x 16 mm assembly screws	2	417560616
5	Aluminium assembly rings	2	74350488
6	SAE 1/4" x 3/8" adapter	1	3900172
7	SAE 1/4" adapter for HP R134a	1	3900173
8	SAE 3/8" adapter for HP R134a	1	3900174
9	SAE 1/4" adapter for HP R1234yf	1	3906803
10	SAE 3/8" adapter for HP R1234yf	1	3906804
11	SAE 1/4" adapter for LP R1234yF	1	3904225

4 TECHNICAL FEATURES

Model	ACKF01 FLUSHING KIT
Manufacturer	TEXA S.p.A.
Refrigerant	R134a - R1234yf
Maximum pressure	21 bar
Filtering efficiency	50 micron
Vessel capacity	6.2 litres
Service pipe length	3000 mm

5 INSTALLATION

The procedure described below indicates the installation of the **ACKF01 FLUSHING KIT** on the KONFORT charging stations Series 700R.



Turn off the charging station and disconnect the power cable from the mains before proceeding with the installation operations.

Proceed as follows:

1. Open the kit and make sure all the components are present.
2. Go on the left side of the charging station.
3. Insert the aluminium rings onto the assembly screws.
4. Screw the screws in their specific holes using an hex key.



5. Place the cleaning vessel close to the aluminium rings.



6. Insert the aluminium rings into the specific holes in the metal plate on the cleaning vessel.



7. Move the cleaning vessel downwards until it settles around the aluminium rings.



The vessel installed this way can be removed whenever it is not used.

6 PREPARING THE CHARGING STATION

Prepare the charging station following the instructions indicated below.
Proceed as follows:

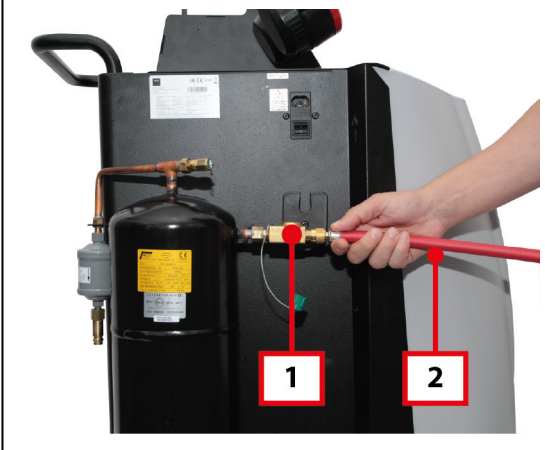
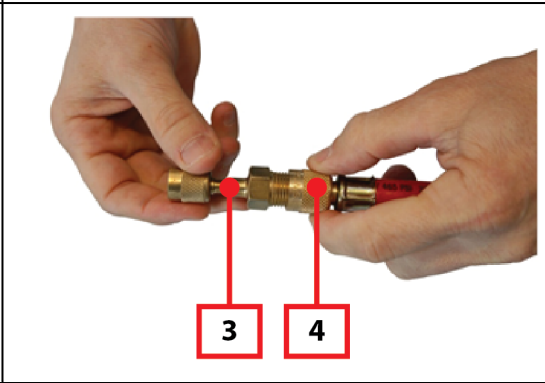
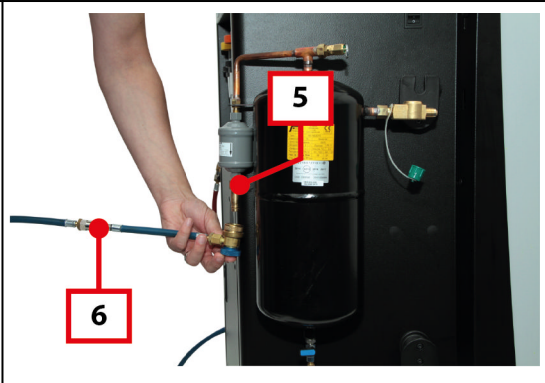
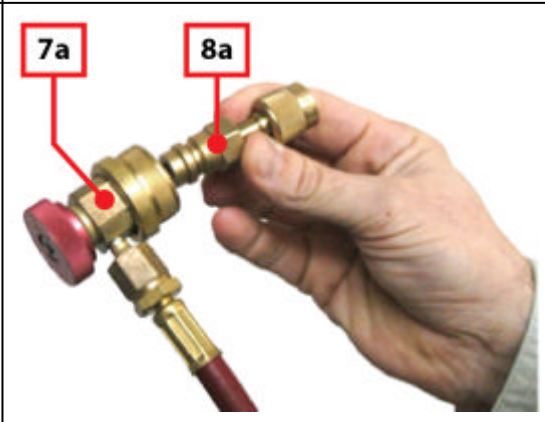
<p>Connect:</p> <p>1 - Red service pipe for the cleaning (code 3900171)</p> <p>2 - Cleaning vessel input (code 74350486)</p>	
<p>Connect:</p> <p>3 - SAE 1/4" x 3/8" adapter (code 3900172)</p> <p>4 - Red service pipe for the cleaning (code 3900171)</p>	
<p>Connect:</p> <p>5 - Cleaning vessel output (code 74350486)</p> <p>6 - Charging station's blue service pipe</p>	
<p>Connect:</p> <p>7a - Charging station's red service pipe</p> <p>8b - SAE 1/4" adapter for HP R134a (code 3900173)</p>	

If using the Audi-Volkswagen adapter set, connect:

7b - Charging station's red service pipe

8b - SAE 3/8" adapter for HP R134a (code 3900174)

The Audi-Volkswagen adapter set is not included in the flushing kit, it must be purchased from the VW group directly.

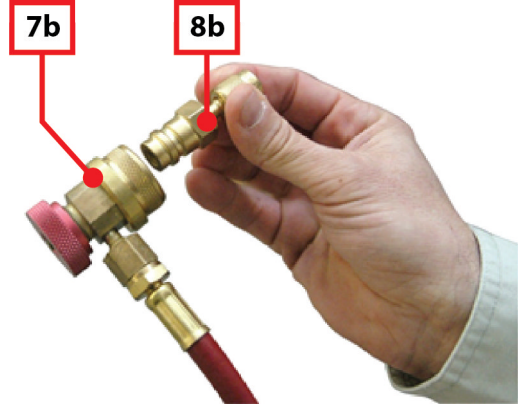

Make sure the charging station's recovered oil bottle (DRAIN) is empty so the oil or UV additive do not overflow.



Make sure the charging station contains **at least 5 kg of R134a refrigerant.**

If the charging station needs to be refilled, refer to the station's technical and user manual.



6.1 Examples of Adapters and Couplers for the Cleaning

Following there are various examples of couplers that can be used to clean the A/C system.

Select the appropriate coupler based on the configuration of the system involved (the universal cleaning adapter case, code 3134, contains approximately 60 different types of adapters).

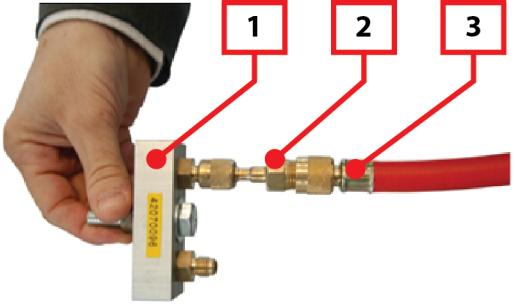
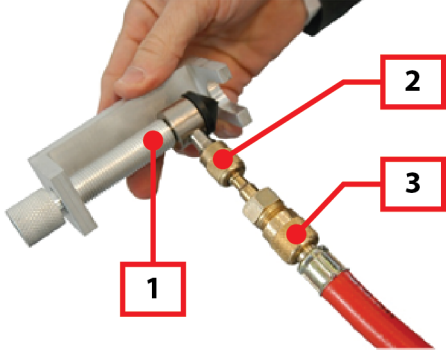
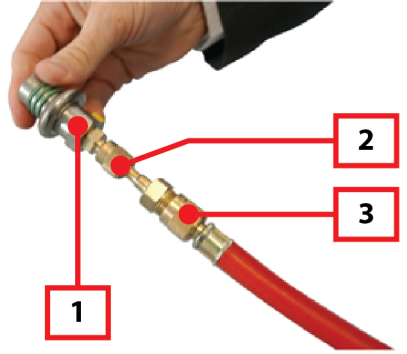
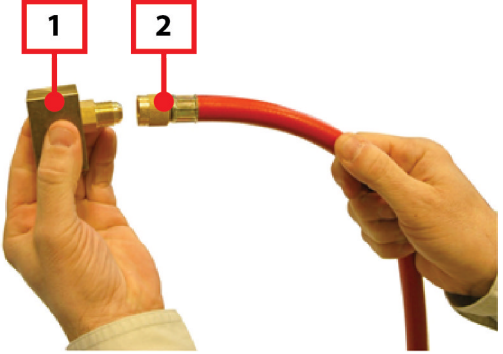
<p>Example 1</p> <ol style="list-style-type: none"> 1. Compressor bridge (code 42070096) 2. SAE 1/4" x 3/8" adapter (code 3900172) 3. Red service pipe for the cleaning (code 3900171) 	
<p>Example 2</p> <ol style="list-style-type: none"> 1. Universal adapter (code 42070098) 2. SAE 1/4" x 3/8" adapter (code 3900172) 3. Red service pipe for the cleaning (code 3900171) 	
<p>Example 3</p> <ol style="list-style-type: none"> 1. "Spring lock" adapter (code 42070086) 2. SAE 1/4" x 3/8" adapter (code 3900172) 3. Red service pipe for the cleaning (code 3900171) 	
<p>Example 4</p> <ol style="list-style-type: none"> 1. Specific Audi-Volkswagen adapter 2. Red service pipe for the cleaning (code 3900171) 	

Example 5

1. Charging station's red service pipe
2. SAE 1/4" adapter for HP R134a (code 3900173)
3. Compressor bridge (code 42070096)

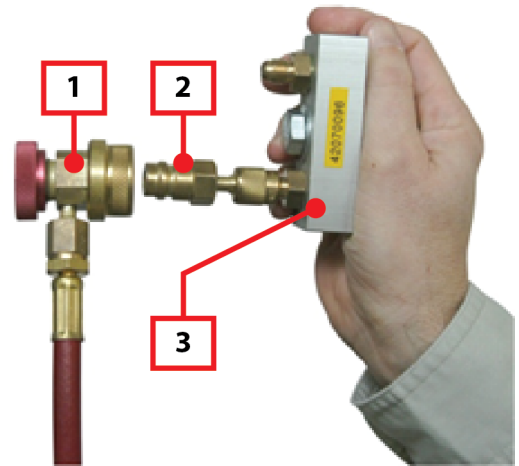

Example 6

1. Universal adapter (code 42070098)
2. SAE 1/4" adapter for HP R134a (code 3900173)
3. Charging station's red service pipe



Example 7

1. "Spring lock" adapter (code 42070086)
2. SAE 1/4" adapter for HP R134a (code 3900173)
3. Charging station's red service pipe



Example 8

1. Specific Audi-Volkswagen adapter
2. SAE 3/8" adapter for HP R134a (code 3900174)
3. Charging station's red service pipe



7 PREPARING THE A/C SYSTEM

Based on the system's configuration, you must remove some components and install specific bridges and adapters.

Below is the description of the operations that must be carried out base on the type of system.

The following are the operations that must be carried out that are common to all system types:

1. *Make sure the vehicle's engine is off.*
2. *Disconnect the battery.*
3. *Make sure the A/C system does not have any type of refrigerant.*



Carefully follow the safety rules related to handling refrigerants.

7.1 Systems with the "Block" Type Expansion Valve

Components that must be Removed

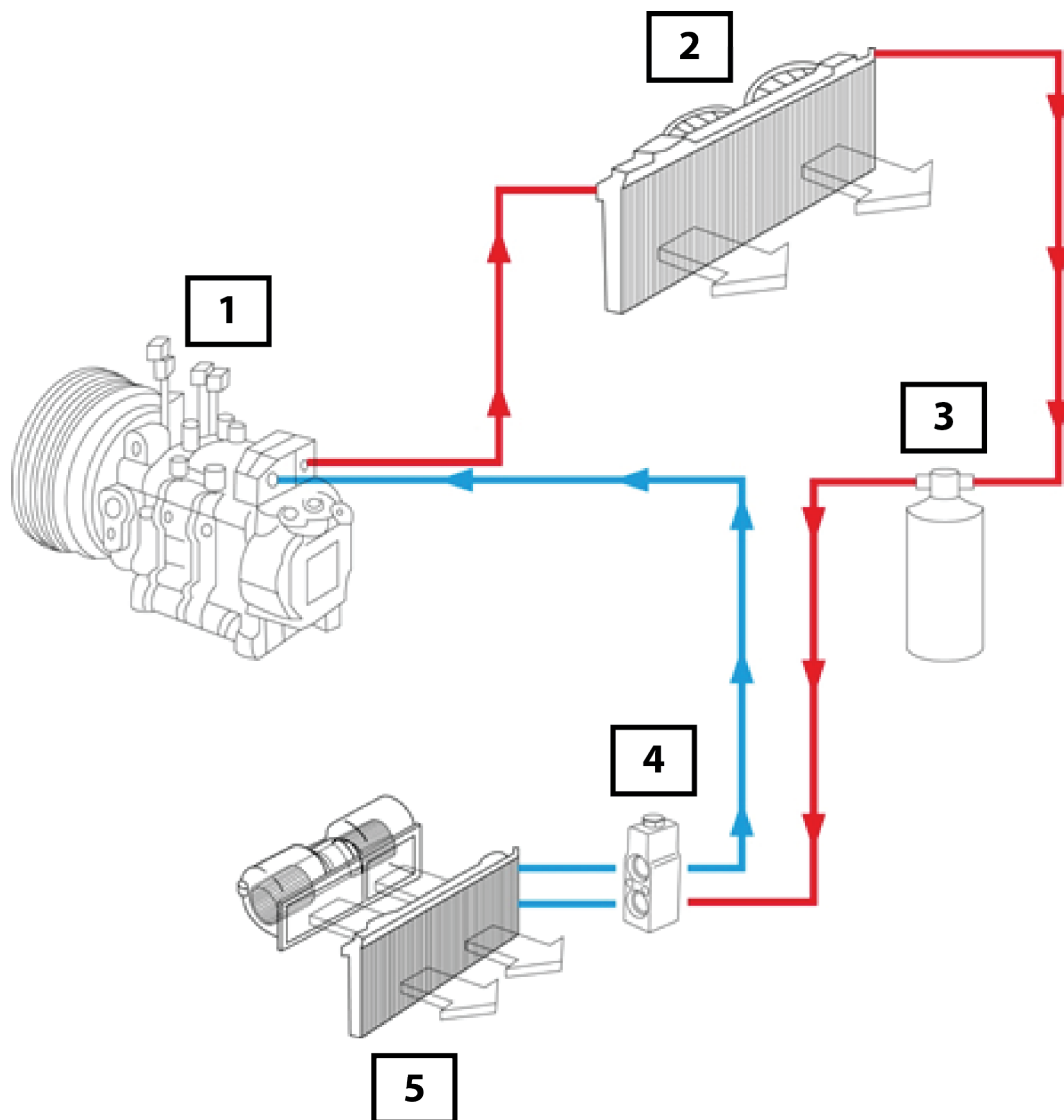

Legend	Components that must be Removed
<ol style="list-style-type: none">1. Compressor2. Condenser3. Dryer filter4. "Block" type expansion valve5. Evaporator	<ul style="list-style-type: none">• Compressor• Dryer filter• "Block" type expansion valve

Bridges / Adapters that must be Installed

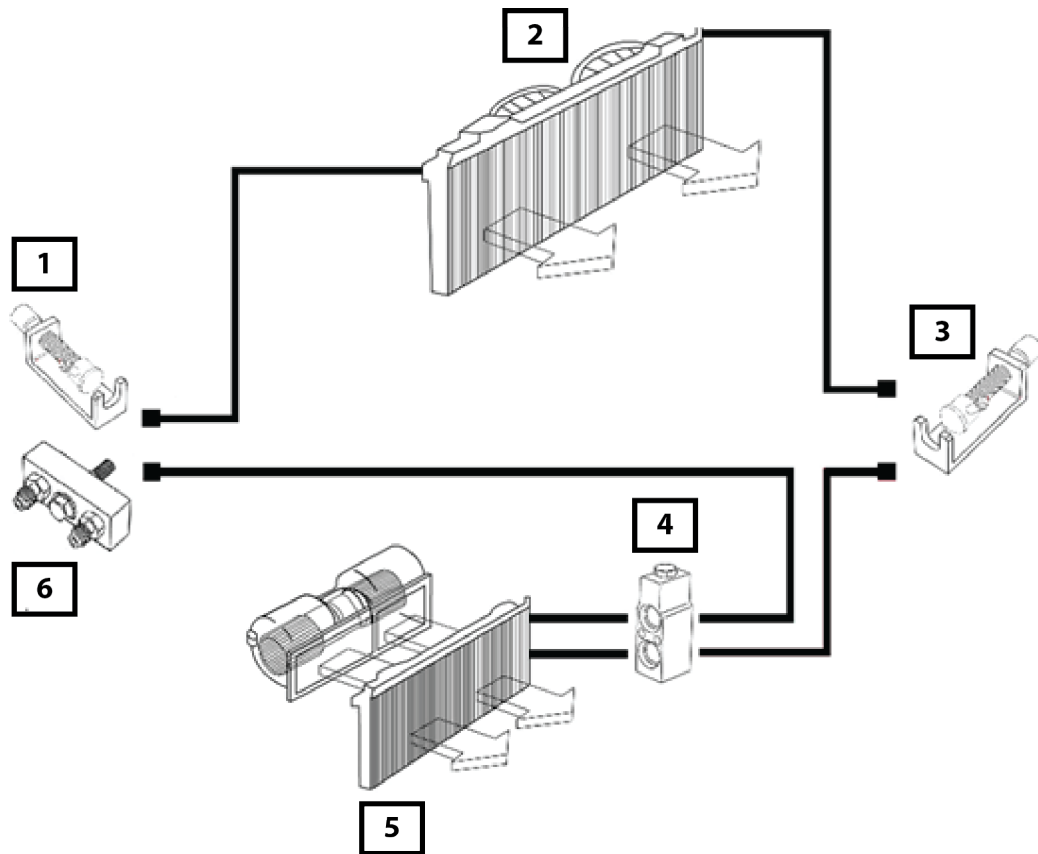

Legend	Bridges / Adapters that must be Installed
<ol style="list-style-type: none"> 1. Universal adapter 2. Condenser 3. Universal adapter 4. Bridge for the "block" type expansion valve 5. Evaporator 6. Bridge for the compressor 	<ul style="list-style-type: none"> • Universal adapter (x2) • Bridge for the compressor • Bridge for the "block" type expansion valve

Proceed as follows:

1. Install a universal adapter and the bridge for the compressor in place of the compressor.
2. Install a universal adapter in place of the dryer filter.
3. Install the bridge for the "block" type expansion valve.

7.2 System with the Thermostatic Expansion Valve (TXV)

Components that must be Removed

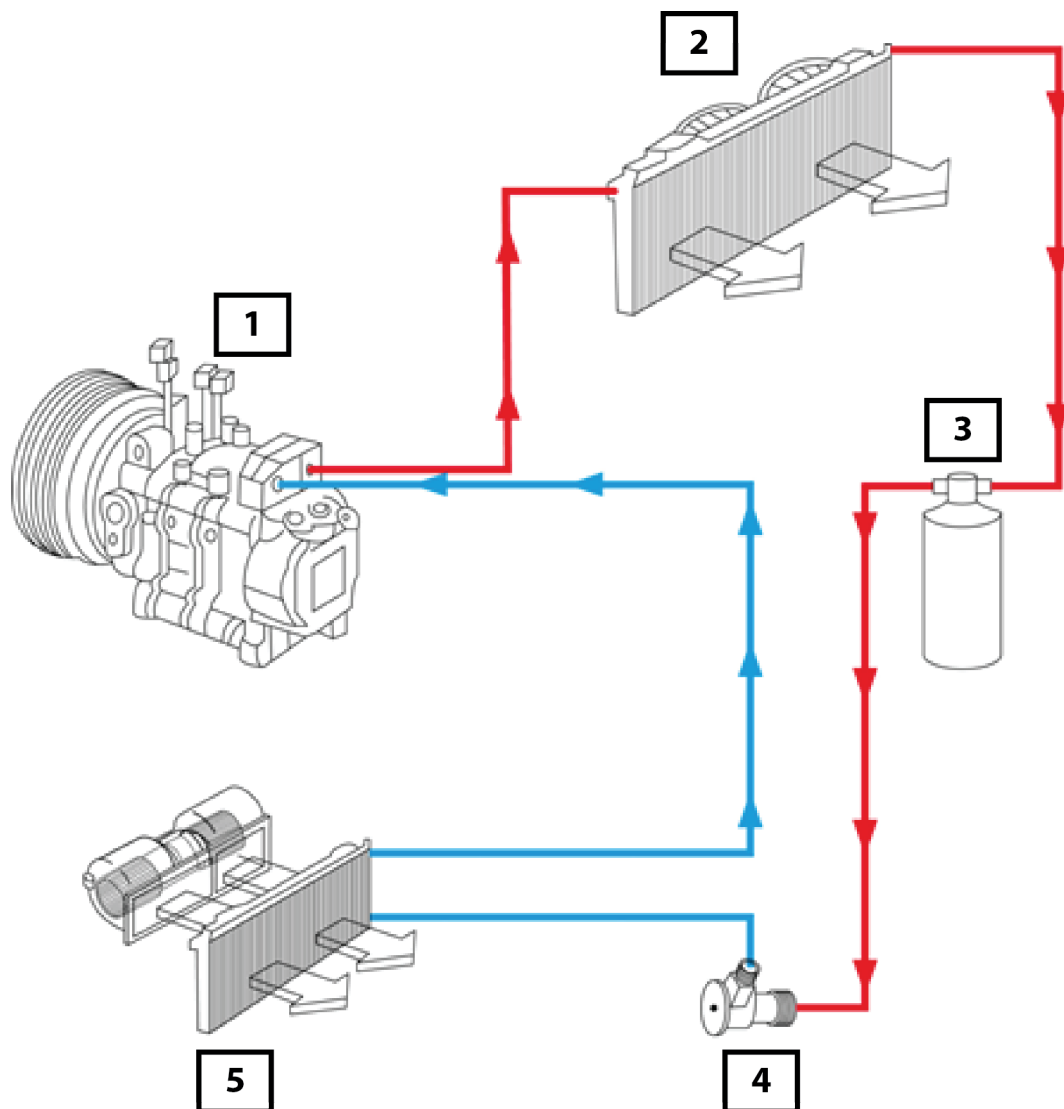

Legend	Components that must be Removed
<ol style="list-style-type: none">1. Compressor2. Condenser3. Dryer filter4. Thermostatic expansion valve5. Evaporator	<ul style="list-style-type: none">• Compressor• Dryer filter• Thermostatic expansion valve

Bridges / Adapters that must be Installed

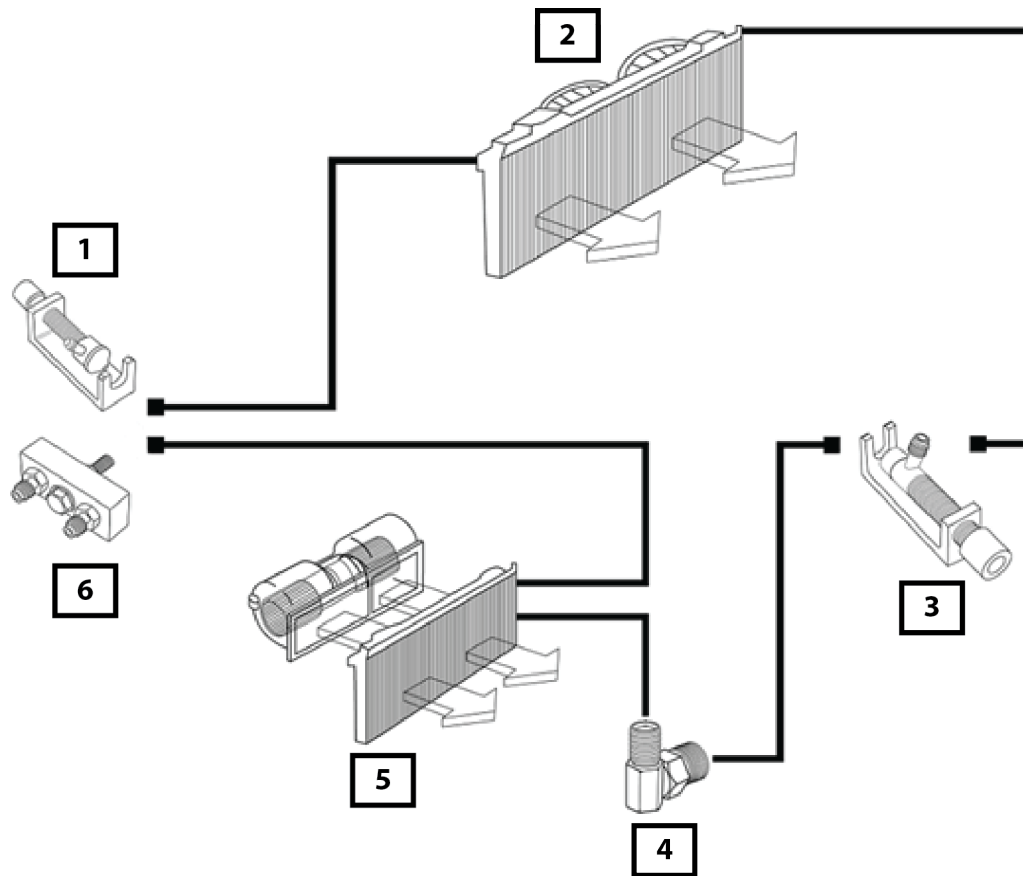

Legend	Bridges / Adapters that must be Installed
<ol style="list-style-type: none"> 1. Universal adapter 2. Condenser 3. Universal adapter 4. Bridge for the thermostatic expansion valve 5. Evaporator 6. Bridge for the compressor 	<ul style="list-style-type: none"> • Universal adapter (x2) • Bridge for the compressor • Bridge for the thermostatic expansion valve.

Proceed as follows:

1. Install a universal adapter and the bridge for the compressor in place of the compressor itself.
2. Install a universal adapter in place of the dryer filter.
3. Install the bridge for the thermostatic expansion valve.

7.3 System with an Orifice Tube

Components that must be Removed

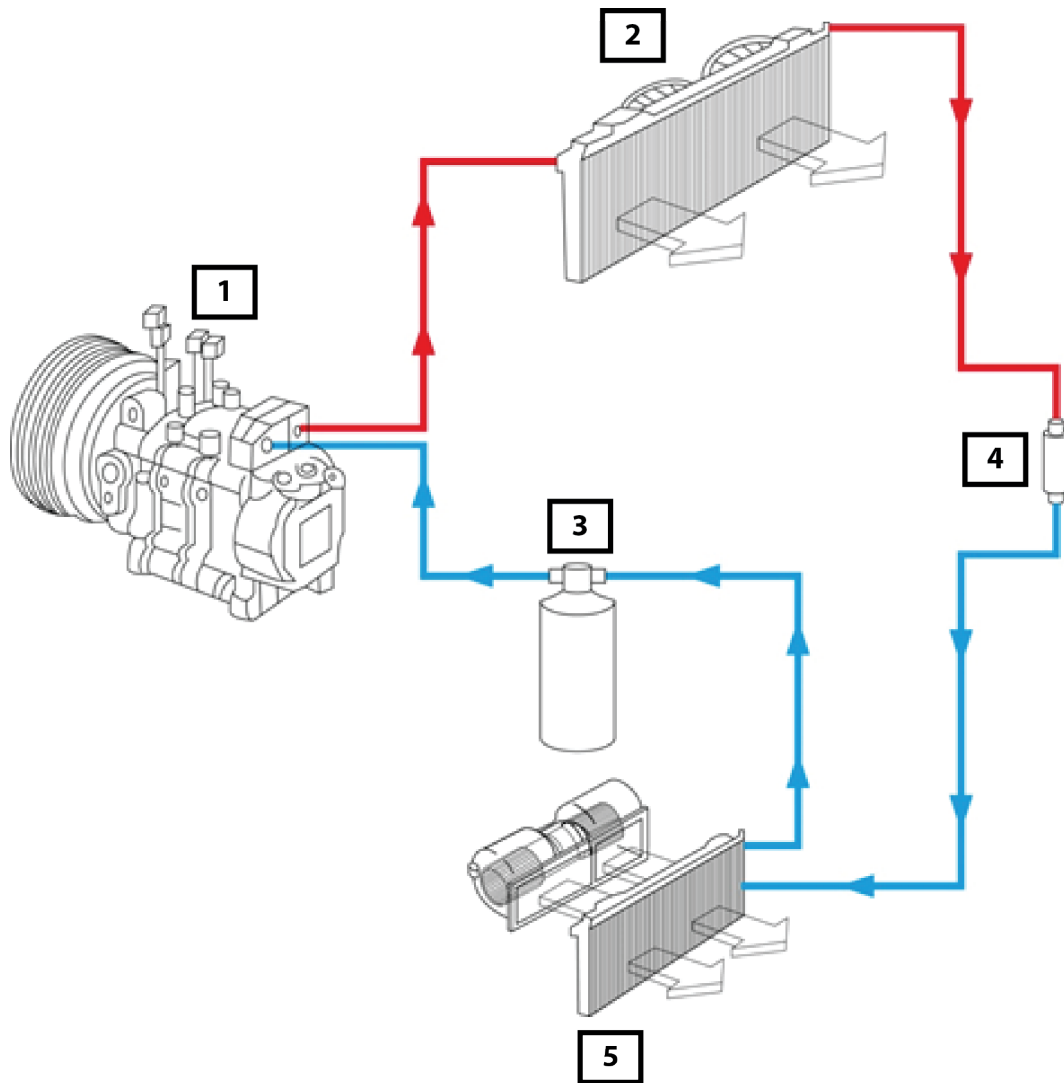

Legend	Components that must be Removed
1. Compressor	
2. Condenser	• Compressor
3. Dryer filter	• Dryer filter
4. Orifice tube	• Orifice tube
5. Evaporator	

Bridges / Adapters that must be Installed

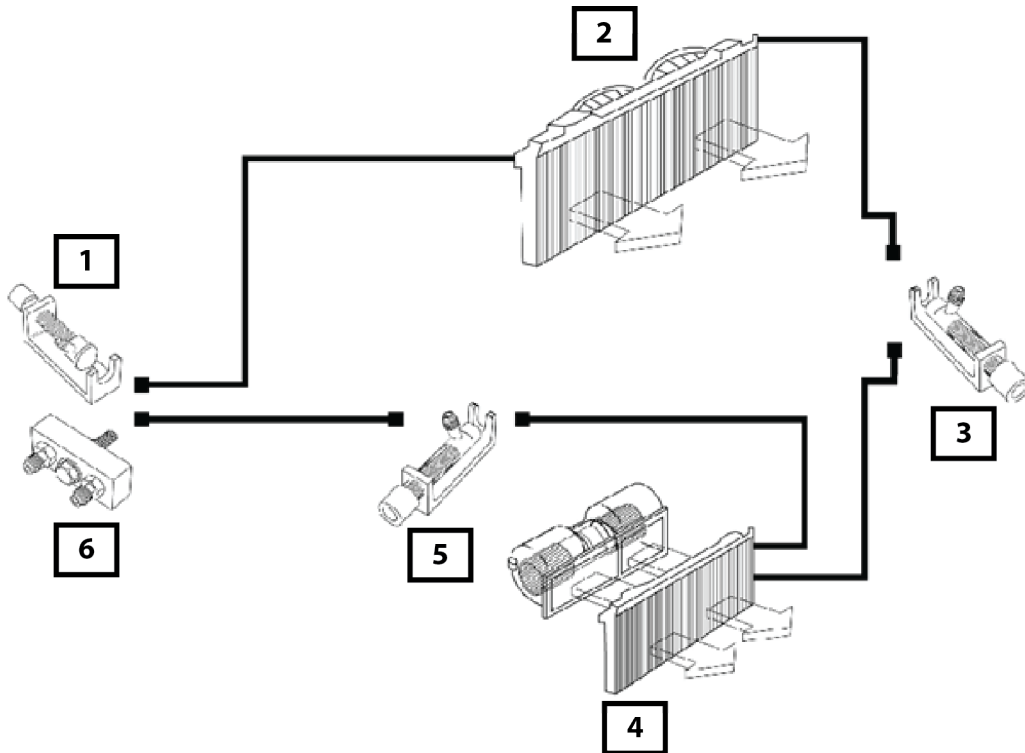

Legend	Bridges / Adapters that must be Installed
<ol style="list-style-type: none"> 1. Universal adapter 2. Condenser 3. Universal adapter 4. Evaporator 5. Universal adapter 6. Bridge for the compressor 	<ul style="list-style-type: none"> • Universal adapter (x3) • Bridge for the compressor • Bridge for the thermostatic expansion valve.

Proceed as follows:

1. Install a universal adapter and the bridge for the compressor in place of the compressor itself.
2. Install a universal adapter in place of the dryer filter.
3. Install a universal adapter in place of the orifice tube

8 KONFORT - A/C SYSTEM CONNECTION

8.1 Cleaning of Systems with an Expansion Valve

Cleaning on evaporator side

In order to prevent contamination in the entire system due to particles from the damaged compressor, you must start cleaning towards the location of the compressor and proceed according to the regular direction of the A/C system flow.

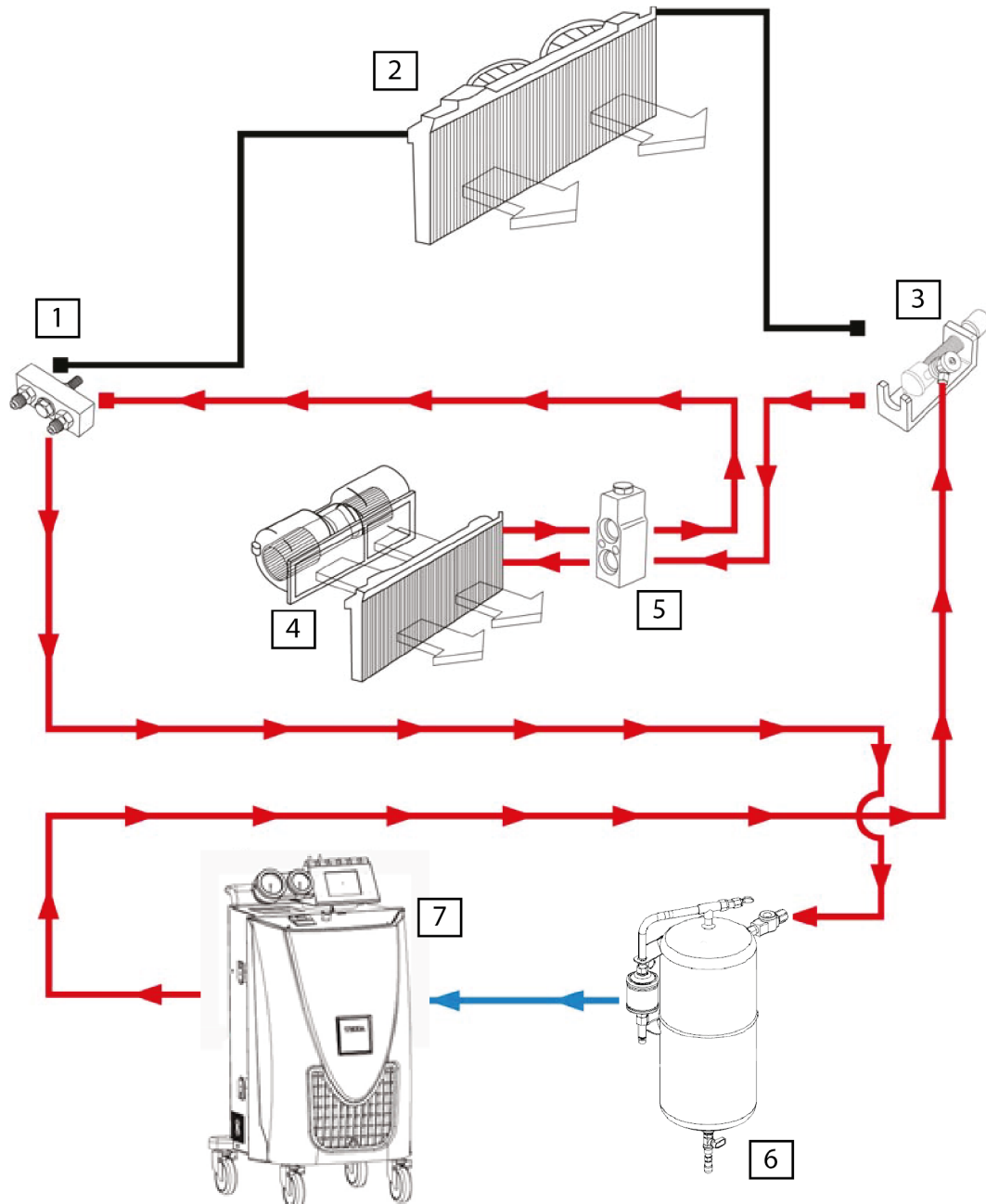

Legend	Notes
<ol style="list-style-type: none"> 1. <i>Bridge for the compressor*</i> 2. <i>Condenser</i> 3. <i>Universal adapter**</i> 4. <i>Evaporator</i> 5. <i>Bridge for the expansion valve</i> 6. <i>Cleaning vessel</i> 7. <i>Charging station</i> 	<p>* Location of the compressor</p> <p>** Location of the dryer filter</p>

Proceed as follows:

1. *Connect the HP coupler of the charging station's red service pipe to the universal adapter installed in place of the dryer filter.*
2. *Connect the red service pipe for the cleaning (code 3900171) to the bridge installed in place of the compressor.*

Backwashing on evaporator side

To carry out the last cleaning step, reverse the couplers previously connected to the system.

This way, backwashing towards the location of the dryer filter can be performed, proceeding in the opposite direction of the A/C system's regular flow.

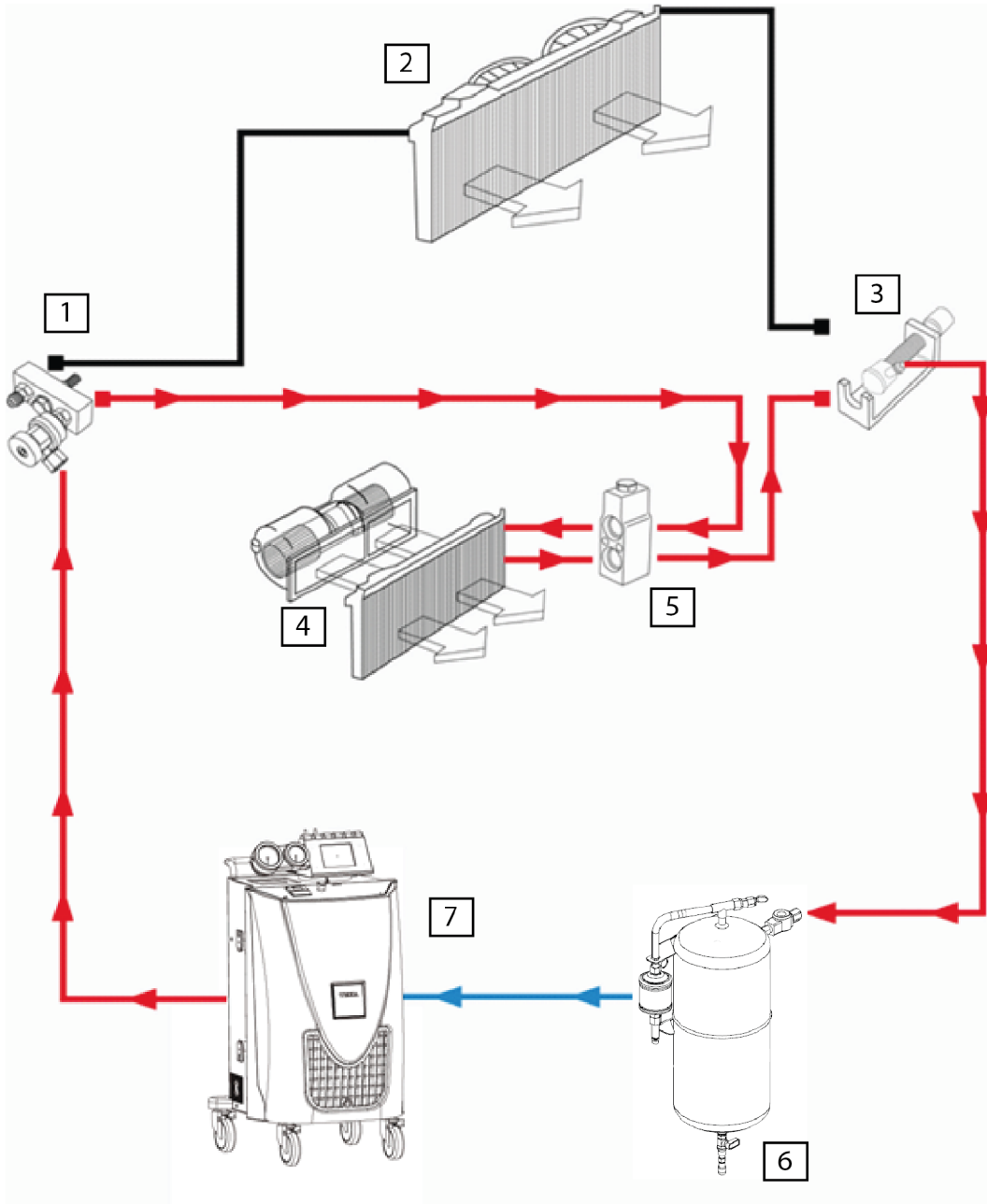

Legend	Notes
<ol style="list-style-type: none"> 1. <i>Bridge for the compressor*</i> 2. <i>Condenser</i> 3. <i>Universal adapter**</i> 4. <i>Evaporator</i> 5. <i>Bridge for the expansion valve</i> 6. <i>Cleaning vessel</i> 7. <i>Charging station</i> 	<p>* Location of the compressor</p> <p>** Location of the dryer filter</p>

Proceed as follows:

1. *Connect the HP coupler of the charging station's red service pipe to the bridge installed in place of the compressor.*
2. *Connect the red service pipe for the cleaning (code 3900171) to the universal adapter installed in place of the dryer filter.*

Cleaning on condenser side

In order to prevent contamination in the entire system due to particles from the damaged compressor, start cleaning towards the location of the compressor and proceed in the opposite direction of the A/C system's regular flow.

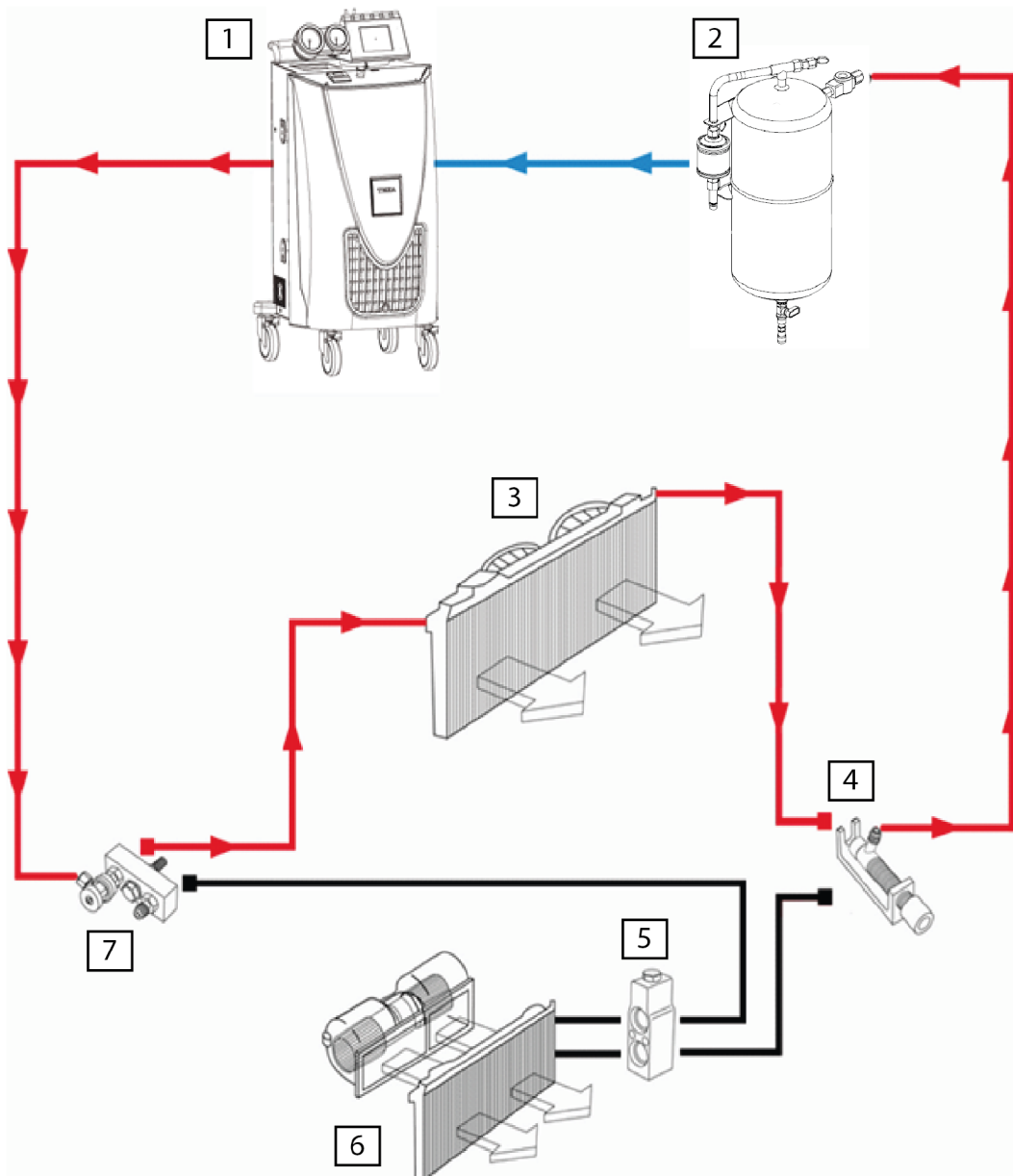

Legend	Notes
<ol style="list-style-type: none"> 1. Bridge for the compressor* 2. Condenser 3. Universal adapter** 4. Evaporator 5. Bridge for the thermostatic valve 6. Cleaning vessel 7. Charging station 	<p>* Location of the compressor</p> <p>** Location of the dryer filter</p>

Proceed as follows:

1. *Connect the HP coupler of the charging station's red service pipe to the universal adapter installed in place of the dryer filter.*
2. *Connect the red service pipe for the cleaning (code 3900171) to the bridge installed in place of the compressor.*

Backwashing on condenser side

To carry out the last cleaning step, reverse the couplers connected to the system.

This way, backwashing towards the location of the dryer filter can be performed, proceeding in the opposite direction of the A/C system's regular flow.

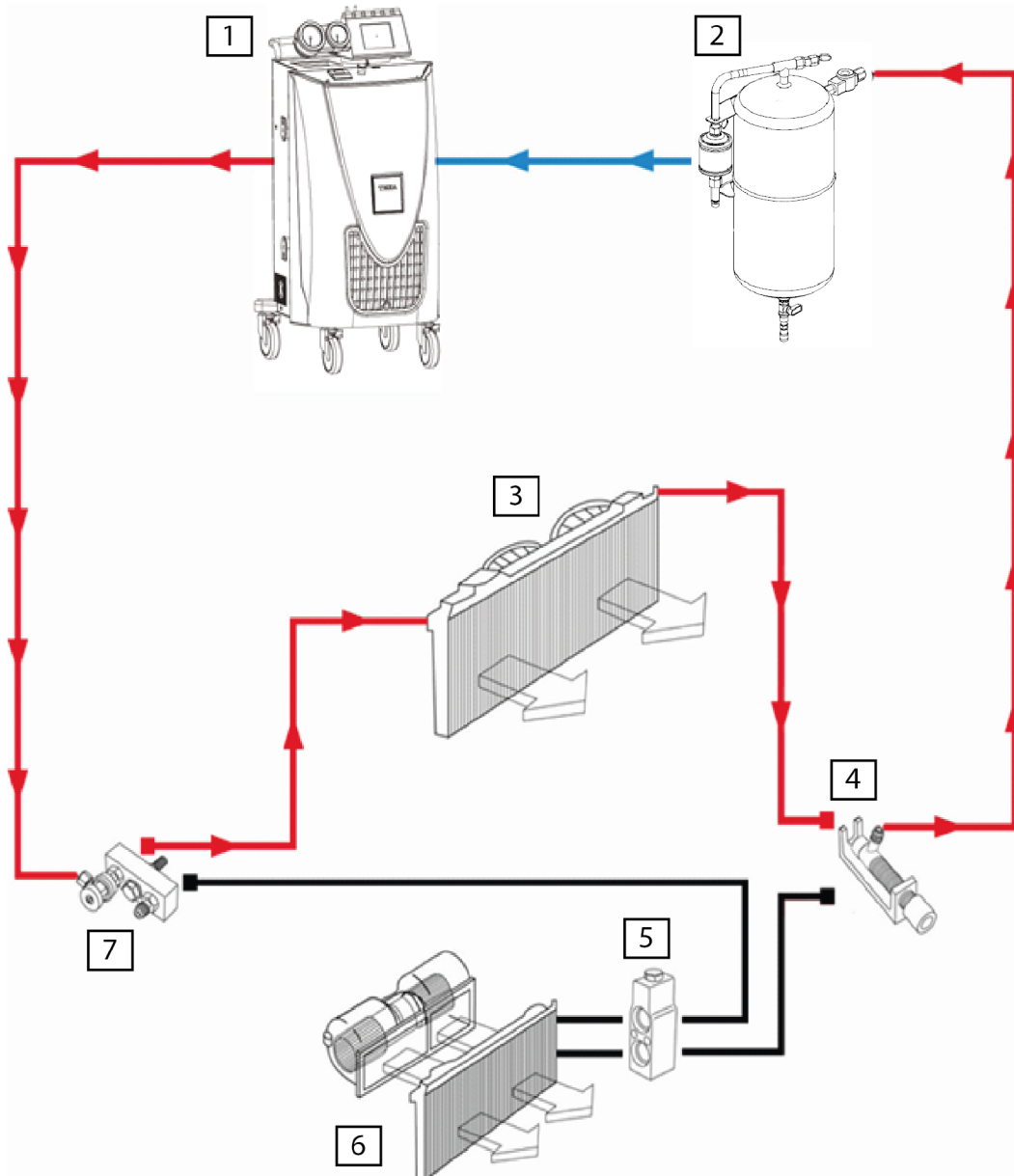

Legend	Notes
1. Bridge for the compressor*	* Location of the compressor ** Location of the dryer filter
2. Condenser	
3. Universal adapter**	
4. Evaporator	
5. Bridge for the thermostatic valve	
6. Cleaning vessel	
7. Charging station	

Proceed as follows:

1. *Connect the HP coupler of the charging station's red service pipe to the bridge installed in place of the compressor.*
2. *Connect the red service pipe for the cleaning (code 3900171) to the universal adapter installed in place of the dryer filter.*

8.2 Cleaning of Systems with a Orifice Tube

Cleaning on evaporator side

In order to prevent contamination in the entire system due to particles from the damaged compressor, start cleaning towards the location of the accumulator, according to the regular direction of the A/C system flow.

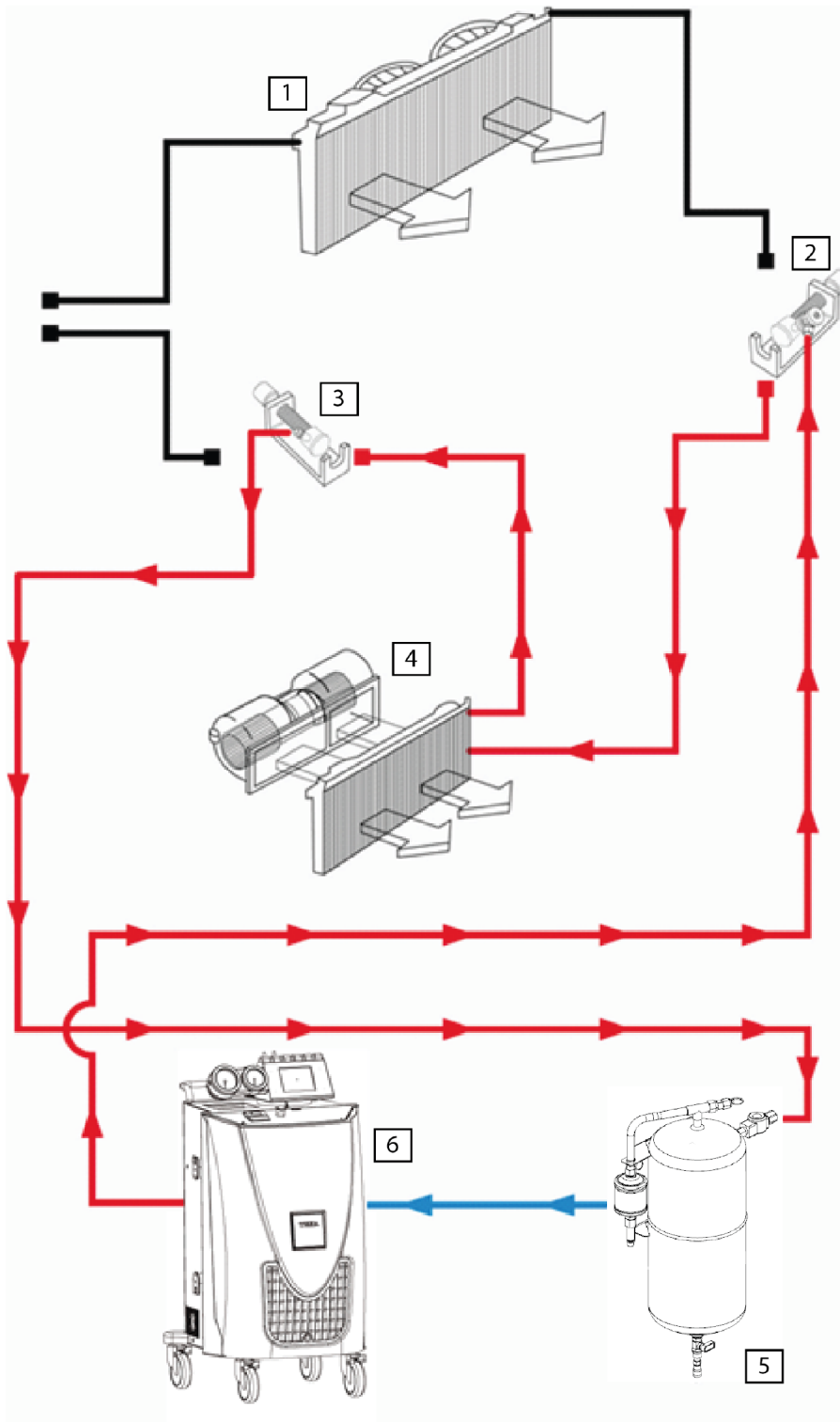

Legend	Notes
1. <i>Condenser</i>	
2. <i>Universal adapter*</i>	
3. <i>Universal adapter**</i>	* Location of the orifice tube
4. <i>Evaporator</i>	** Location of the accumulator
5. <i>Cleaning vessel</i>	
6. <i>Charging station</i>	

Proceed as follows:

1. *Connect the HP coupler of the charging station's red service pipe to the universal adapter installed in place of the orifice tube.*
2. *Connect the red service pipe for the cleaning (code 3900171) to the universal adapter installed in place of the accumulator.*

Backwashing on evaporator side

To carry out the last cleaning step, reverse the couplers connected to the system.

This way, backwashing towards the location of the orifice tube can be performed, proceeding in the opposite direction of the A/C system's regular flow.

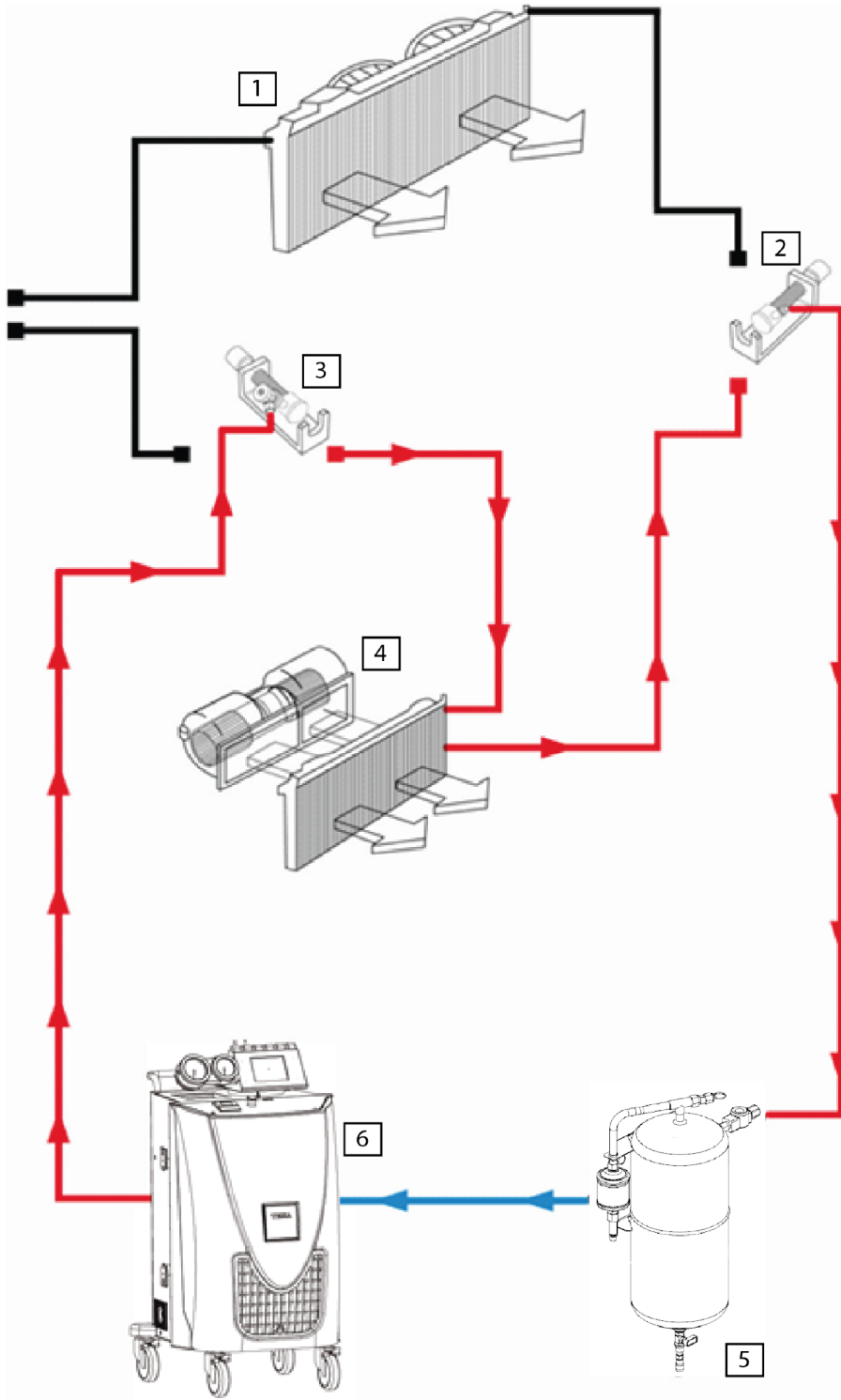

Legend	Notes
1. <i>Condenser</i>	
2. <i>Universal adapter*</i>	
3. <i>Universal adapter**</i>	* Location of the orifice tube
4. <i>Evaporator</i>	** Location of the accumulator
5. <i>Cleaning vessel</i>	
6. <i>Charging station</i>	

Proceed as follows:

1. *Connect the HP coupler of the charging station's red service pipe to the universal adapter installed in place of the accumulator.*
2. *Connect the red service pipe for the cleaning (code 3900171) to the universal adapter installed in place of the orifice tube.*

Cleaning of the accumulator-compressor coupler

In order to prevent contamination in the entire system due to particles from the damaged compressor, start cleaning towards the location of the compressor, according to the regular direction of the A/C system flow.

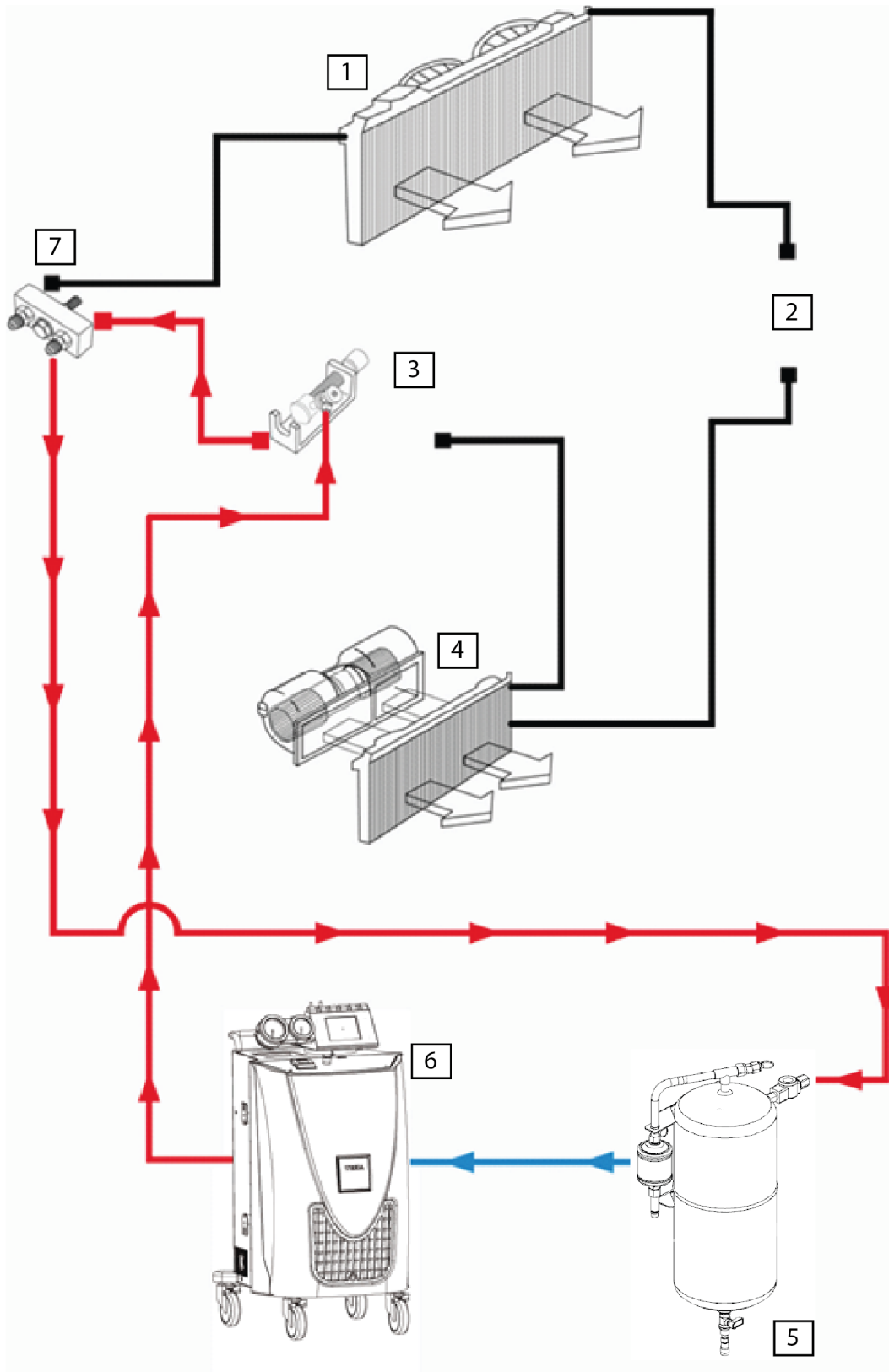

Legend	Notes
--------	-------

<ol style="list-style-type: none">1. <i>Condenser</i>2. <i>Location of the orifice tube</i>3. <i>Universal adapter*</i>4. <i>Evaporator</i>5. <i>Cleaning vessel</i>6. <i>Charging station</i>7. <i>Bridge for the compressor**</i>	<p>* Location of the accumulator</p> <p>** Location of the compressor</p>
---	---

Proceed as follows:

1. *Connect the HP coupler of the charging station's red service pipe to the universal adapter installed in place of the accumulator.*
2. *Connect the red service pipe for the cleaning (code 3900171) to the bridge for the compressor installed in place of the compressor.*

Backwashing of the accumulator-compressor coupler

To carry out the last cleaning step, reverse the couplers connected to the system.

This way, backwashing towards the location of the accumulator can be performed, proceeding in the opposite direction of the A/C system's regular flow.

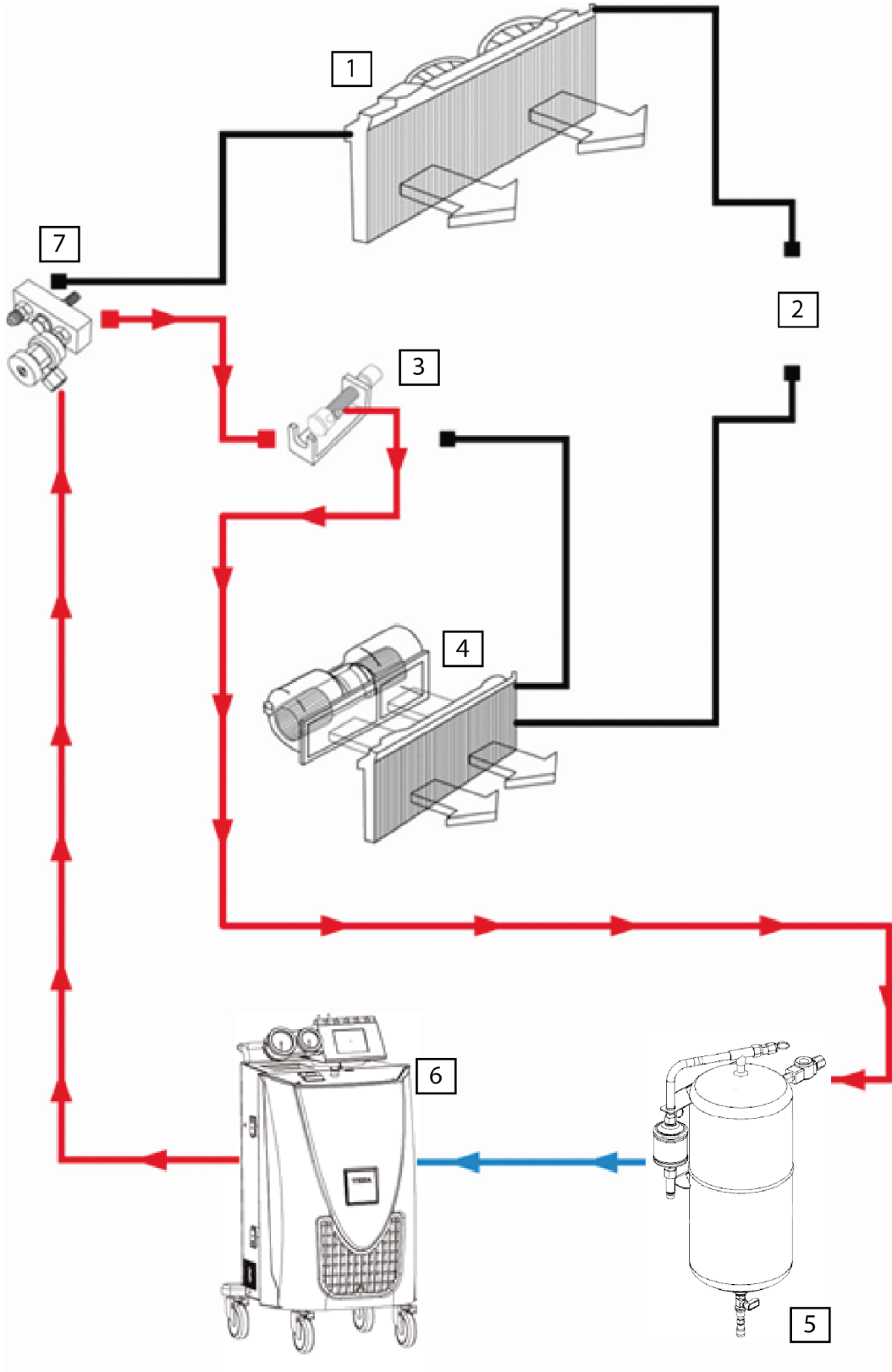

Legend	Notes
<i>1. Condenser</i> <i>2. Location of the orifice tube</i> <i>3. Universal adapter*</i> <i>4. Evaporator</i> <i>5. Cleaning vessel</i> <i>6. Charging station</i> <i>7. Bridge for the compressor**</i>	* Location of the accumulator ** Location of the compressor

Proceed as follows:

- 1. Connect the HP coupler of the charging station's red service pipe to the bridge for the compressor installed in place of the compressor.*
- 2. Connect the red service pipe for the cleaning (code 3900171) to the universal adapter installed in place of the accumulator.*

Cleaning on condenser side

In order to prevent contamination in the entire system due to particles from the damaged compressor, you must always start cleaning towards the compressor and proceed in the opposite direction of the A/C system's regular flow.

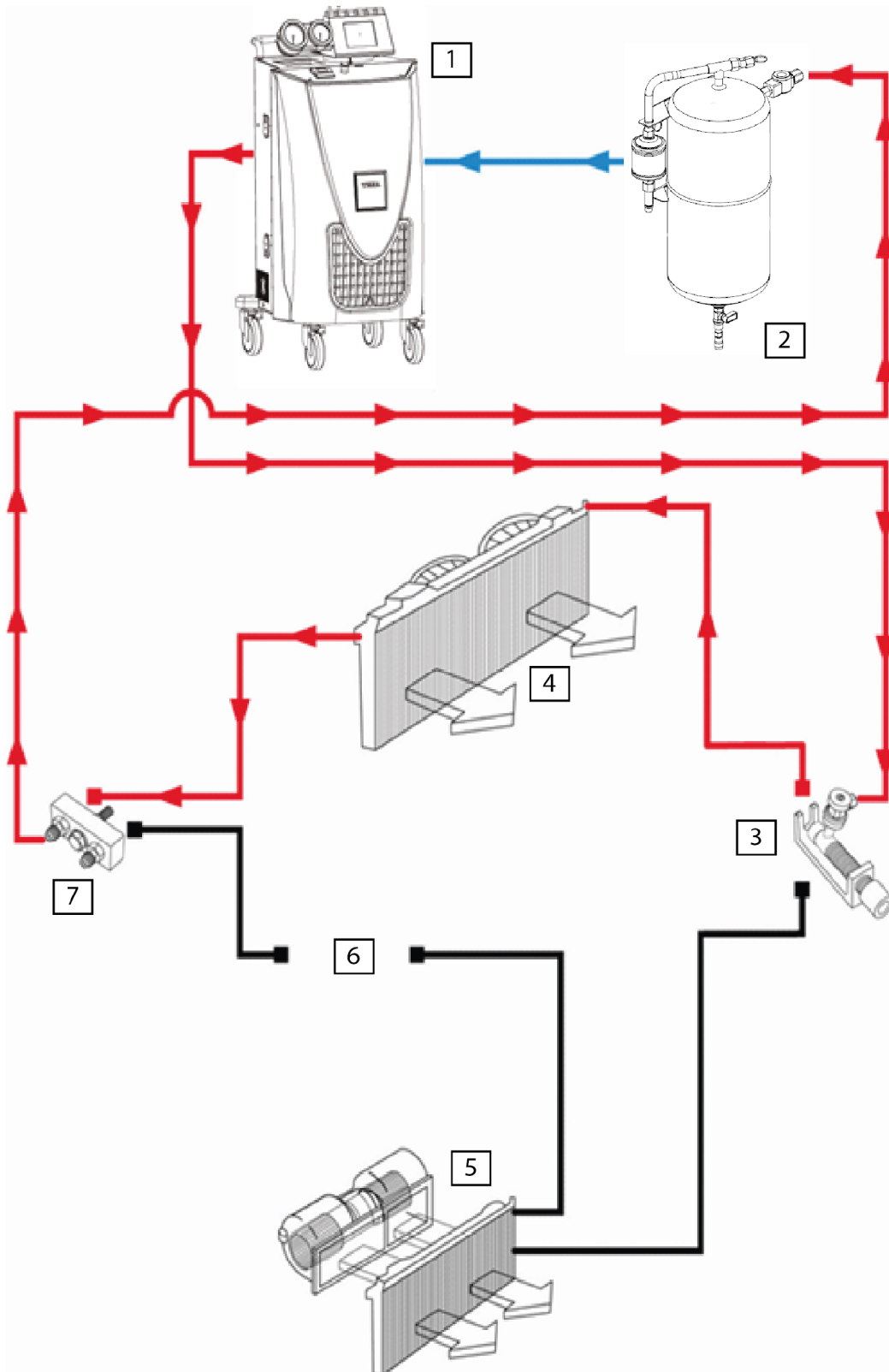

Legend	Notes
<i>1. Charging station</i> <i>2. Cleaning vessel</i> <i>3. Universal adapter*</i> <i>4. Condenser</i> <i>5. Evaporator</i> <i>6. Location of the accumulator</i> <i>7. Bridge for the compressor**</i>	* Location of the orifice tube ** Location of the compressor

Proceed as follows:

- 1. Connect the HP coupler of the charging station's red service pipe to the universal adapter installed in place of the orifice tube.*
- 2. Connect the red service pipe for the cleaning (code 3900171) in place of the accumulator.*

Backwashing on condenser side

To carry out the last cleaning step, reverse the couplers connected to the system.

This way, backwashing towards the location of the orifice tube can be performed, according to the regular direction of the A/C system flow.

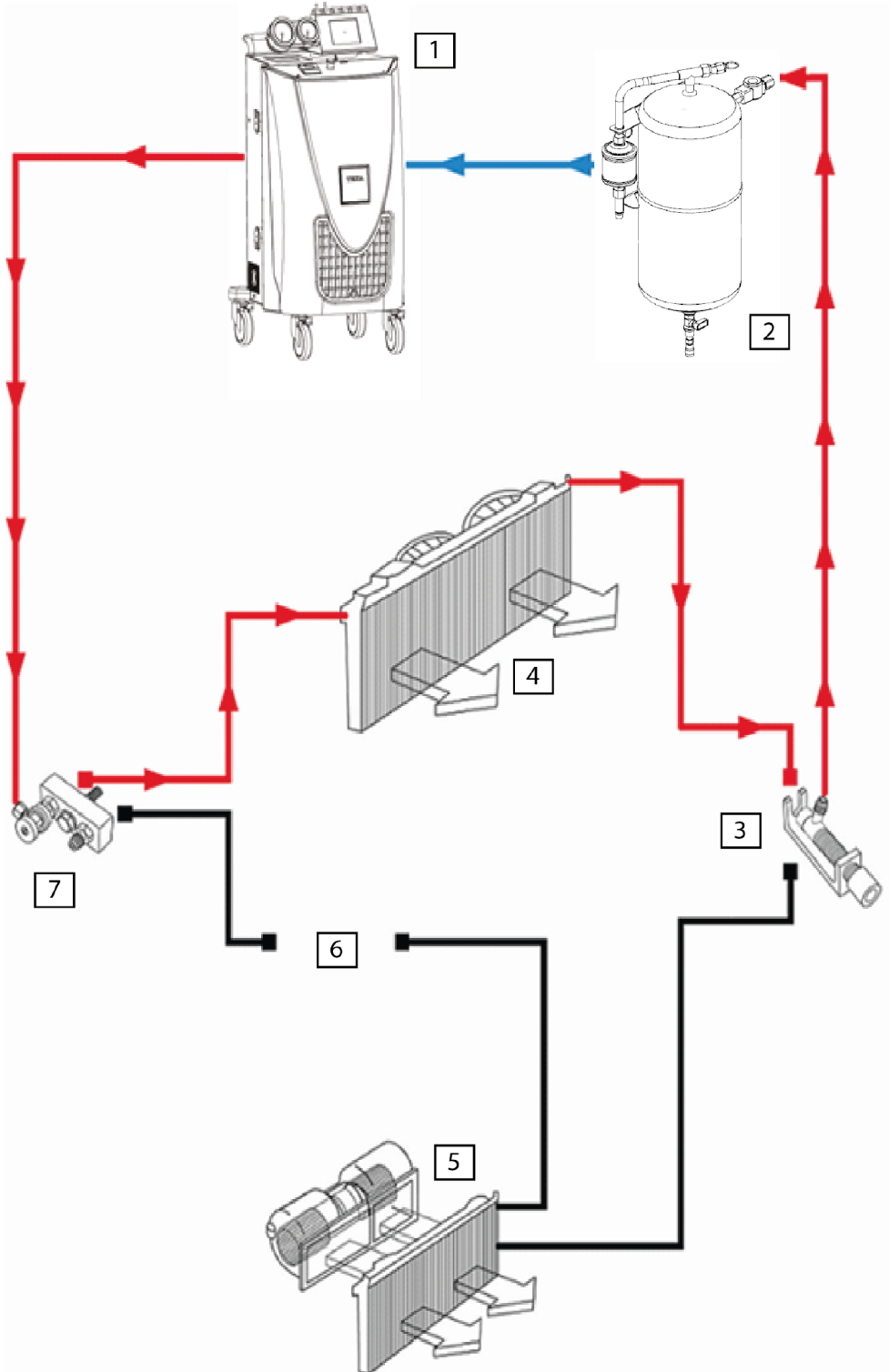

Legend	Notes
<i>1. Charging station</i> <i>2. Cleaning vessel</i> <i>3. Universal adapter*</i> <i>4. Condenser</i> <i>5. Evaporator</i> <i>6. Location of the accumulator</i> <i>7. Bridge for the compressor**</i>	* Location of the orifice tube ** Location of the compressor

Proceed as follows:

- 1. Connect the HP coupler of the charging station's red service pipe in place of the accumulator.*
- 2. Connect the red service pipe for the cleaning (code 3900171) to the universal adapter installed in place of the orifice tube.*

9 FLUSHING

The cleaning or flushing can be **single** or **multiple**:

SINGLE FLUSHING	This type of flushing performs only one cleaning cycle. The single flushing is recommended for small contaminations and/or for simply removing the oil / UV additive.
MULTIPLE FLUSHING	This type of flushing runs three or more consecutive cleaning cycles. The number of cycles can be set by the operator. The system or the component is put under vacuum only during the first cleaning cycle. The multiple flushing is recommended when there is a heavy contamination caused by relevant damage such as a broken compressor.

A standard cleaning cycle is composed of the following phases:

- 1. system or component that must be cleaned put under vacuum;*
- 2. leak test on the system and couplers;*
- 3. cleaning with a liquid refrigerant;*
- 4. recovery and recycling of the contaminated refrigerant;*
- 5. separation and discharge of the liquid contaminations.*

	Before starting to clean the system, make sure the charging station and the system are prepared as described in the previous chapters.
---	---

	The cleaning is carried out using the refrigerant initially recovered from the system or from the component that must be cleaned.
---	--

The cleaning vessel is equipped with a coupler that has a control window which allows you to monitor the progress of the cleaning and the conditions of the cleaning agent, the refrigerant.



Through this window you may verify the nature of the contamination that is transported by the refrigerant.

<p>Cleaning agent contaminated with UV additive. (The arrow indicates the direction of the flow)</p>	
<p>Cleaning agent contaminated with dirty oil and/or particles of various nature. (The arrow indicates the direction of the flow)</p>	
<p>Cleaning agent not contaminated. Clean A/C system. (The arrow indicates the direction of the flow)</p>	

The cleaning can be completed:

- *by letting the function advance on its own until the end of the cleaning cycle (single flushing) or cycles (multiple flushing);*
- *by monitoring the passage of the cleaning agent through the control window and interrupting the cleaning when the agent has a light colour (no contaminating elements) pressing  .*

The cleaning can be interrupted at any time by pressing  .

NOTE

As an example, below you will find the images of the screens and buttons on the 760R, 760R BUS, 780R BI-GAS and 770S charging stations.

With the exception of the graphic layout, menu and functions are the same on the 710R and 720R charging stations also.

Proceed as follows:

Turn on the charging station.
Wait for the self-test to complete.
The initial screen appears.

Press  or  .

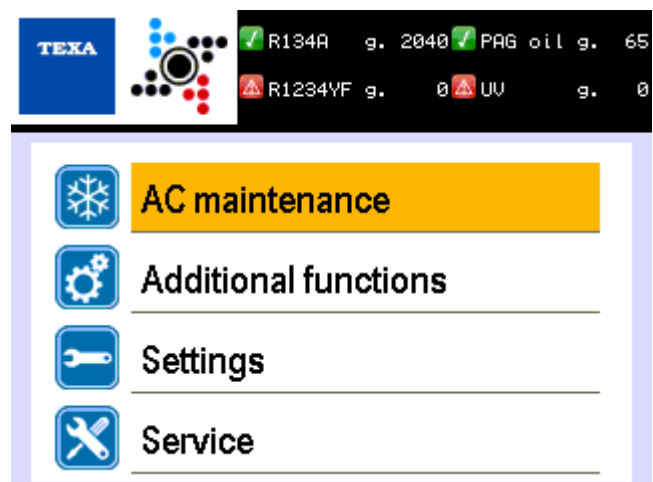

The main menu is displayed.

NOTE

By pressing the button  , all the data that identifies the charging station and the firmware version installed is displayed.

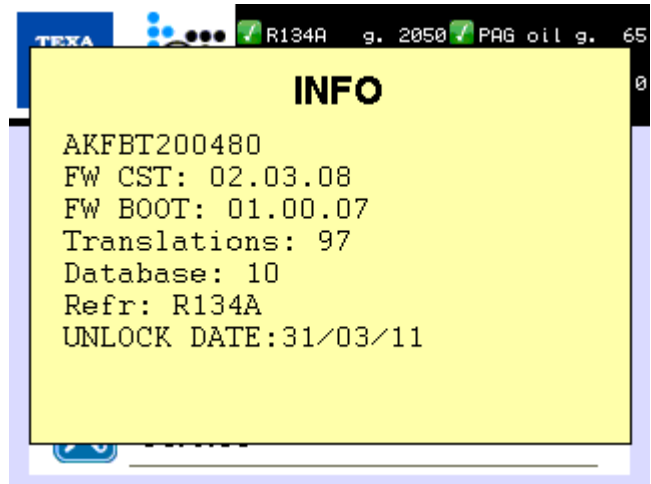

Press  to return to the main menu.

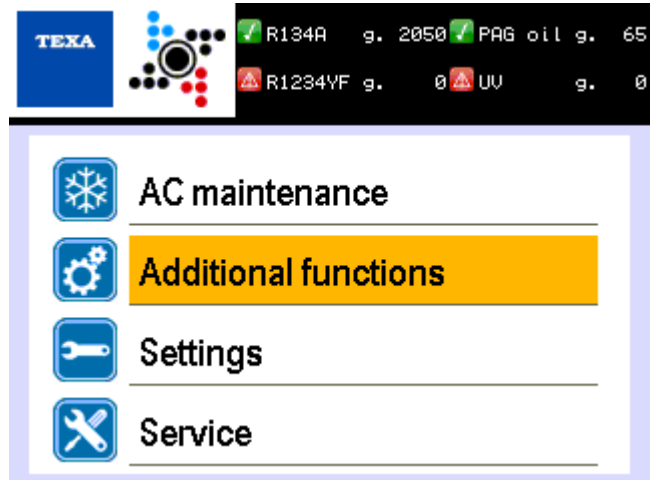

Press  or  until selecting **Additional Functions.**

Press  .



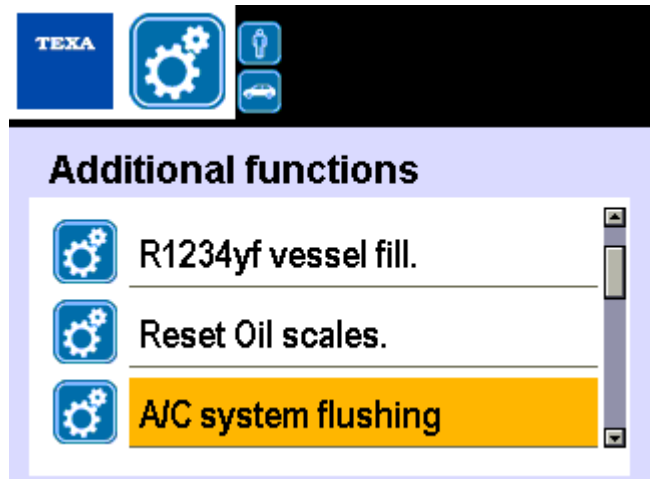

Press  or  until selecting **Flushing.**

Press  .



ONLY ON KONFORT 780R BI-GAS:

Press  or  until selecting the **type of refrigerant** that you wish to use for the cleaning

Press .

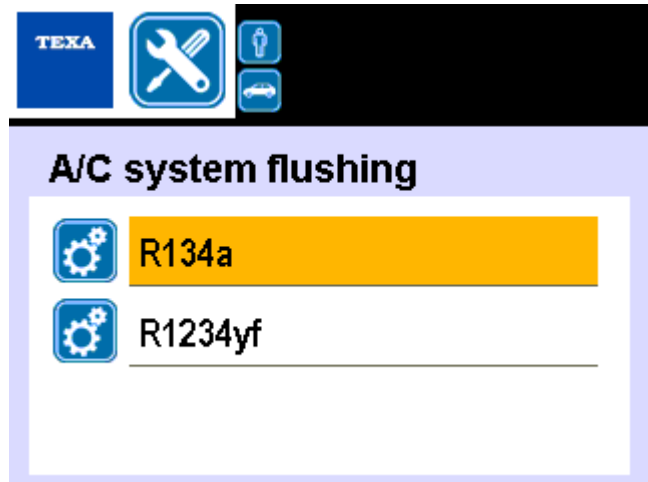

Press  or  until selecting the desired **type of flushing**.

Press .

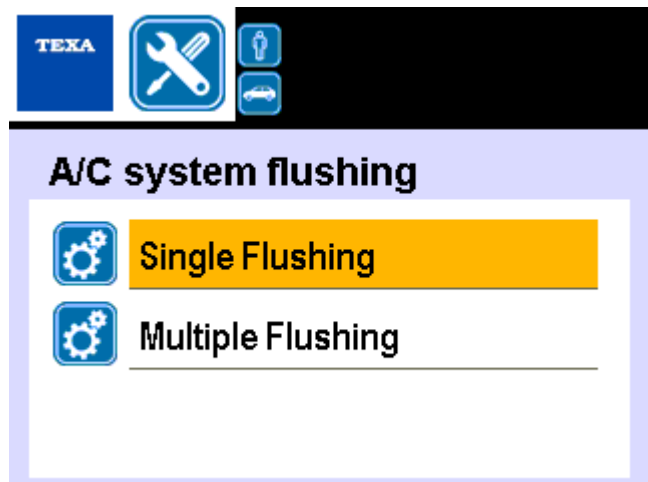

Enter the **customer data** using the alphanumeric keypad.

Press .

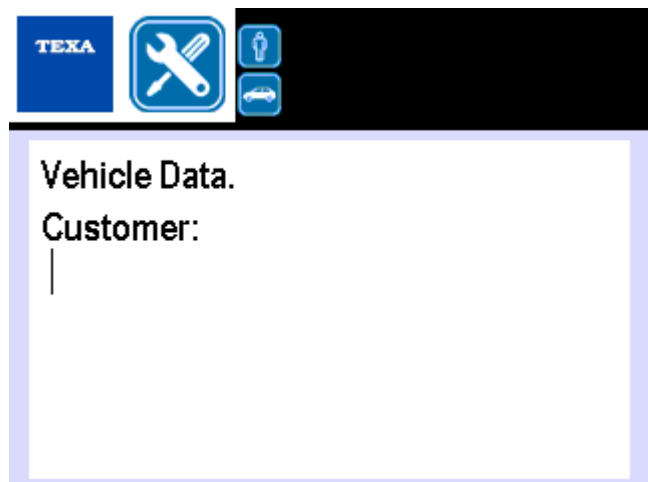

Enter the **vehicle data** using the alphanumeric keypad.

Press .

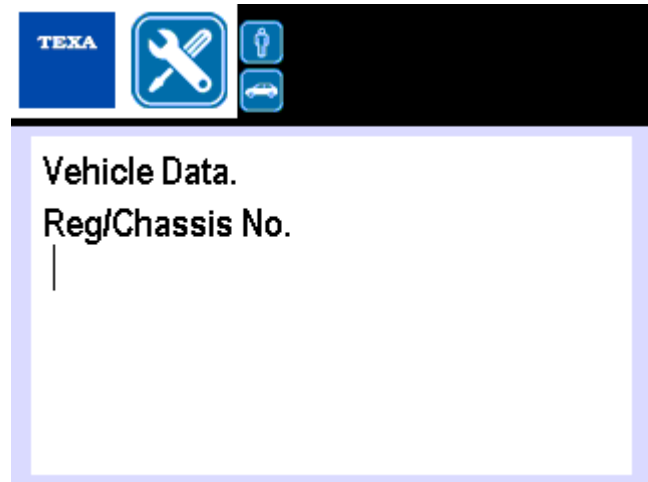

The charging station requires you to run the **Internal Konfort cleaning**.

Press .

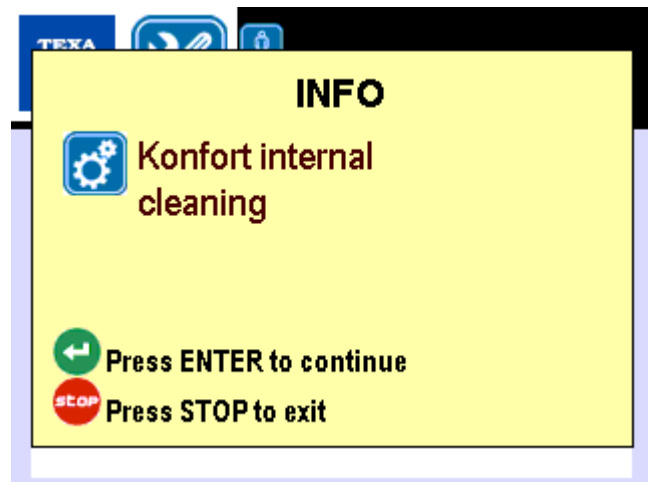

Connect the LP (blue) and HP (red) couplers to the related LP and HP fittings on the side of the charging station.

Press .

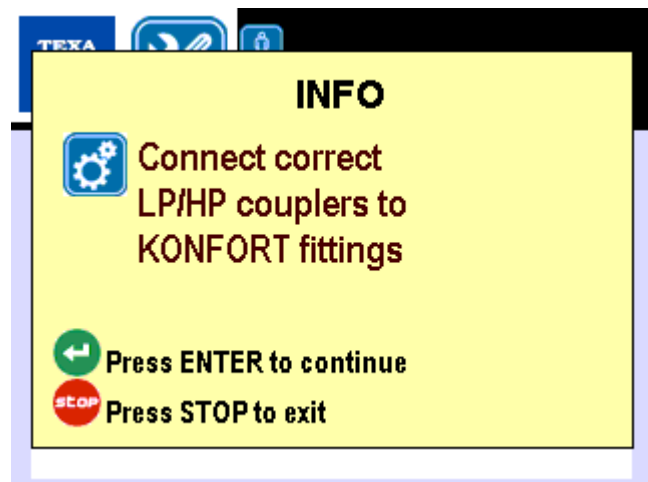

Open the valves on the couplers turning the handwheels clockwise.

Press  .

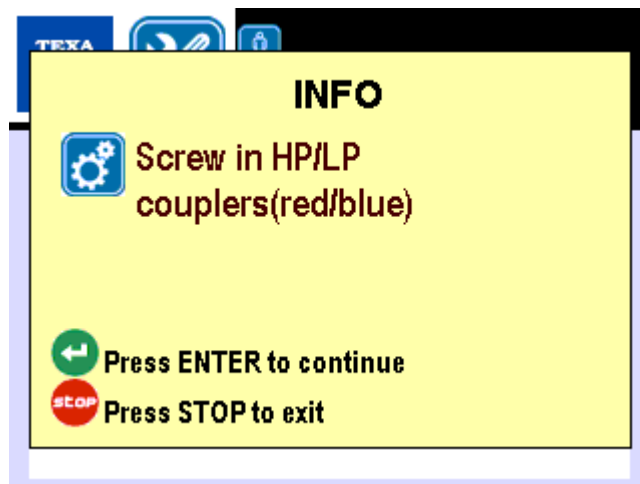

The internal cleaning is launched.

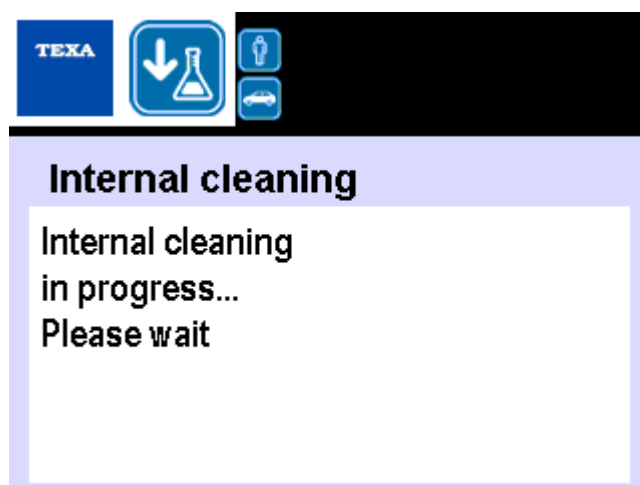

The final phase of the internal cleaning is the automatic check of the recovered oil.

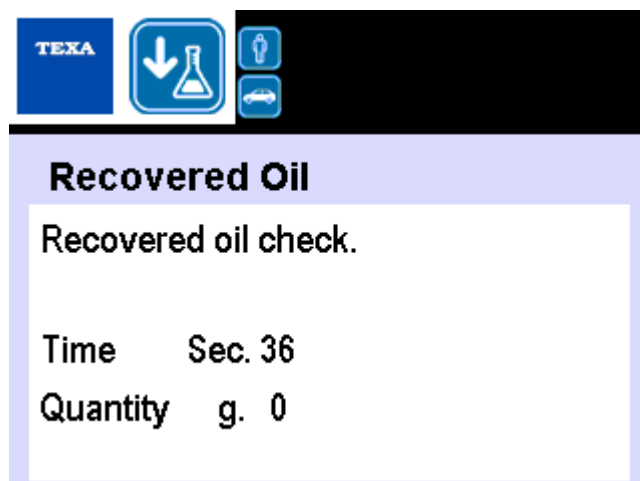

Close the valves on the couplers by turning the handwheels counter-clockwise.

Press .

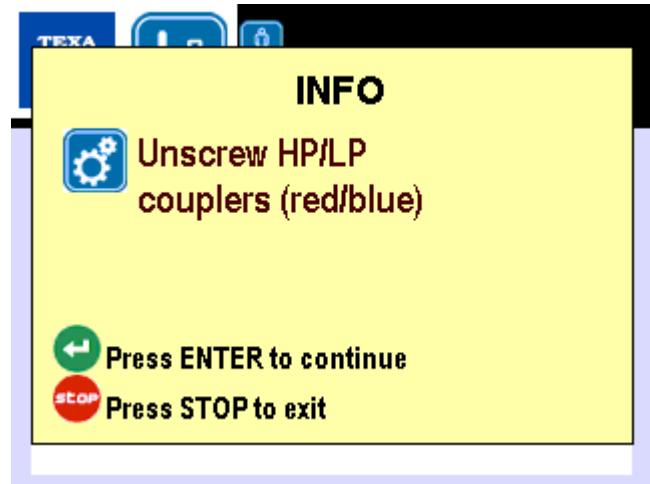

Connect the HP service pipe to the system that must be cleaned.

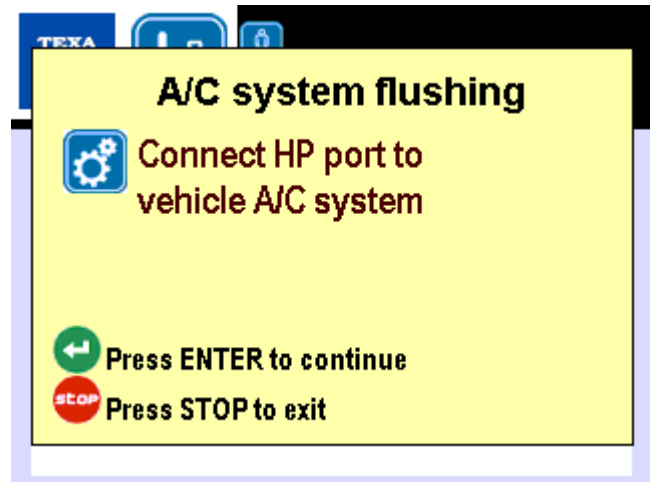

Wait for the system pressure check to end.

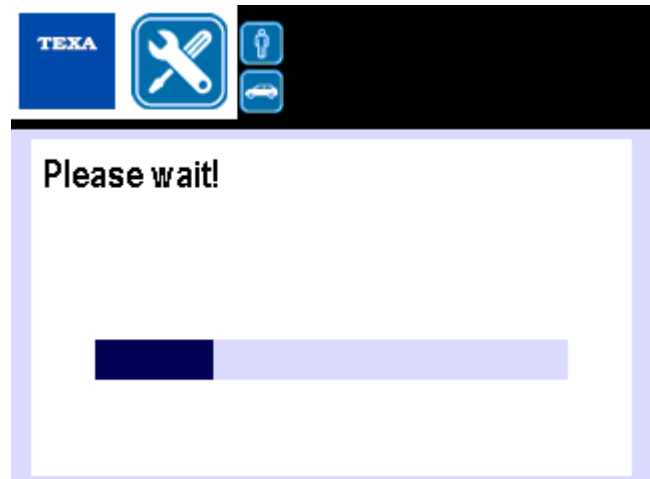

Connect the LP service pipe to the external tank.

Press  .

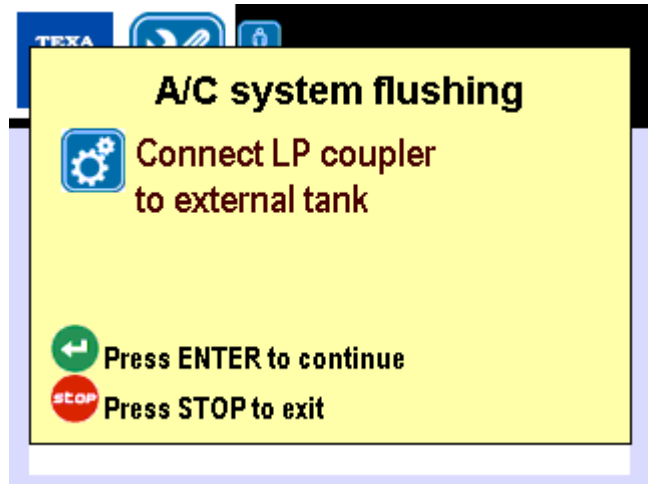

Wait for the system pressure check to end.

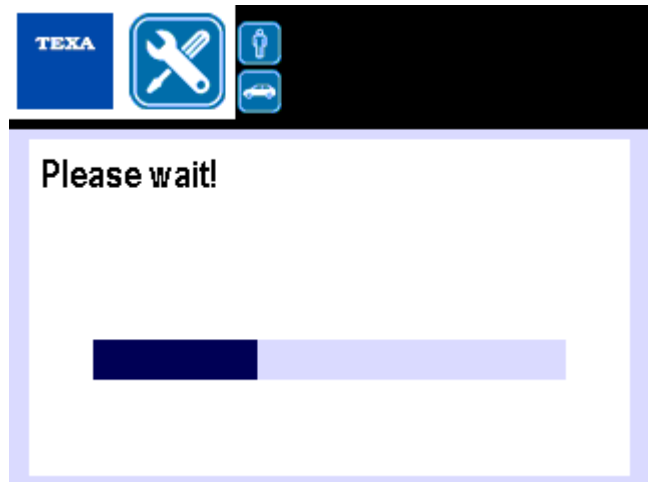

The **vacuum phase** is launched.
The predefined length of this phase is **5 minutes**.

This phase **can be interrupted at any time** by pressing  to go on to the following phase.

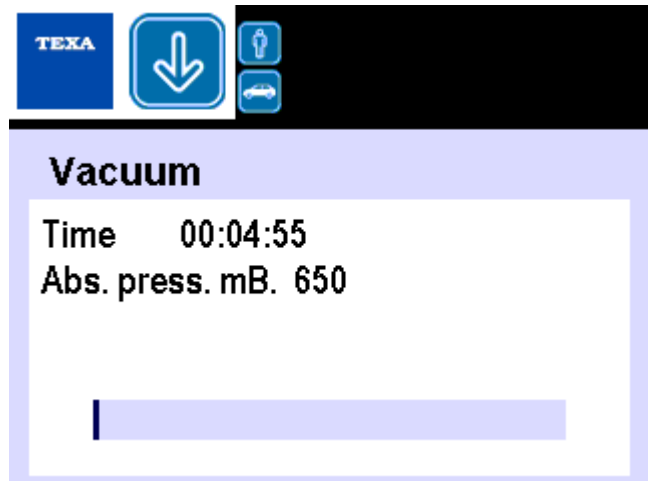

The **leak test** on the couplers is launched.

The predefined length of this phase is **3 minutes**.

This phase **can be interrupted at any**

time by pressing  to go on to the following phase.

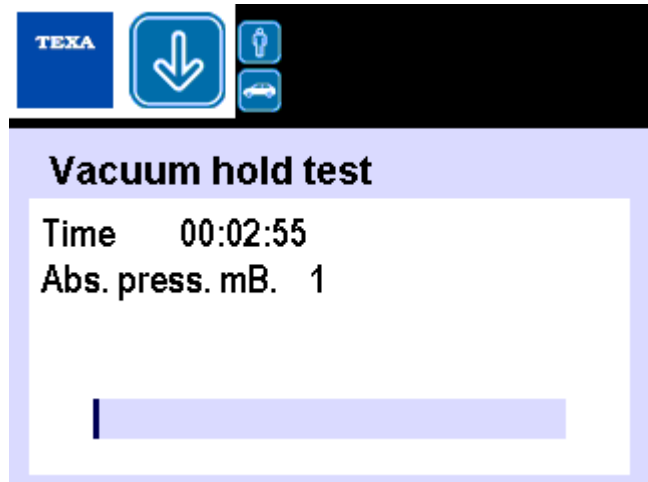



If there are not any leaks the following message is displayed.

The message indicates the value of the vacuum measured up to this moment.

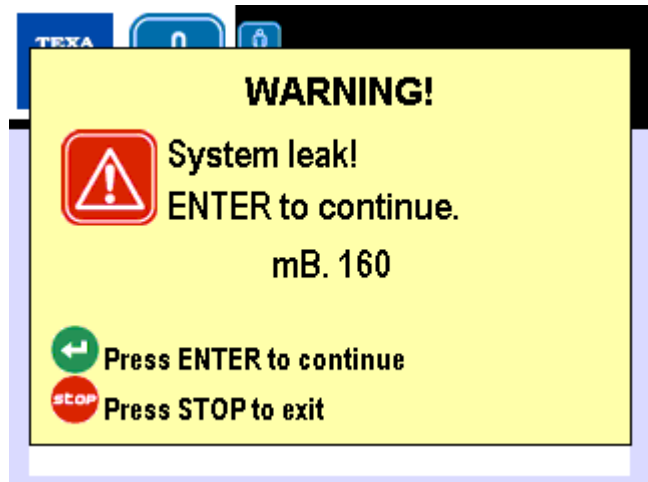
Check the connection to the system and/or to the components.



<p>Leak caused by problems with a prompt solution (ex.; the sealing of a coupler)</p>	<p>Solve the problem. Press . Proceed with the cleaning procedure</p>
<p>Leak caused by problems that are unknown or with a complex solution</p>	<p>Press . Identify the cause of the leak and solve the problem. Restart the cleaning procedure from the beginning.</p>

If there are not any faults, the system is ready for the cleaning.

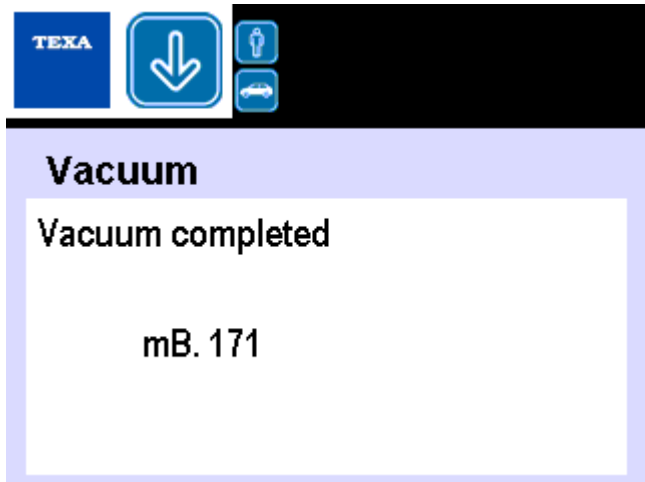

The **cleaning** phase starts.

The liquid refrigerant is loaded into the system, it flows through it and reaches the cleaning vessel filled with the impurities it removed.

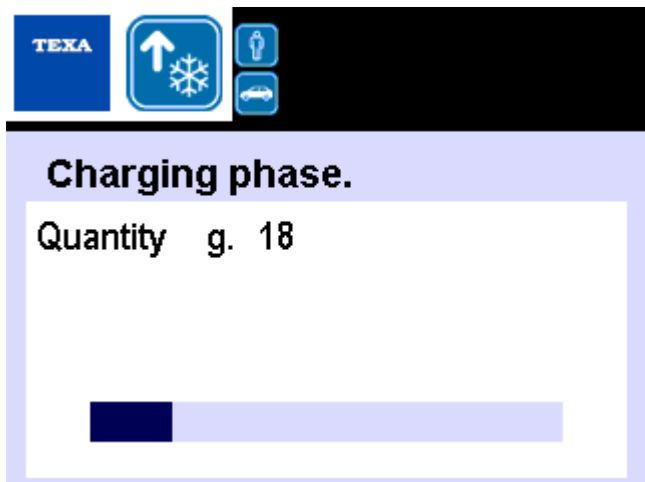

At the end of the **cleaning** phase, the system and/or the components are full of liquid refrigerant.

The cleaning vessel contains the contaminated refrigerant.

In order to empty the system and the cleaning vessel, the refrigerant **recovery** phase is launched.



Once the recovery is complete, the charging station runs a pressure test to verify if there is residual refrigerant trapped in the system and/or in the vessel due to freezing.

Sudden pressure increases may reactivate the recovery until the system is considered perfectly empty.

After the pressure test, the charging station **discharges the liquid contamination** (compressor oil, UV additive) into the waste oil bottle.

The contamination discharge is marked by a countdown.

The amount of liquid contamination is expressed in cc.

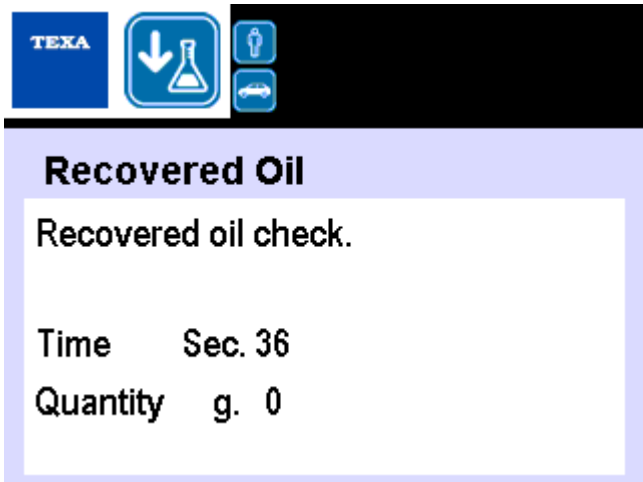

If the charging station is equipped with a printer, a report related to the completed procedure is printed.

The charging station warns about the end of the flushing procedure.

Press  .

The **Additional Functions** menu is displayed.

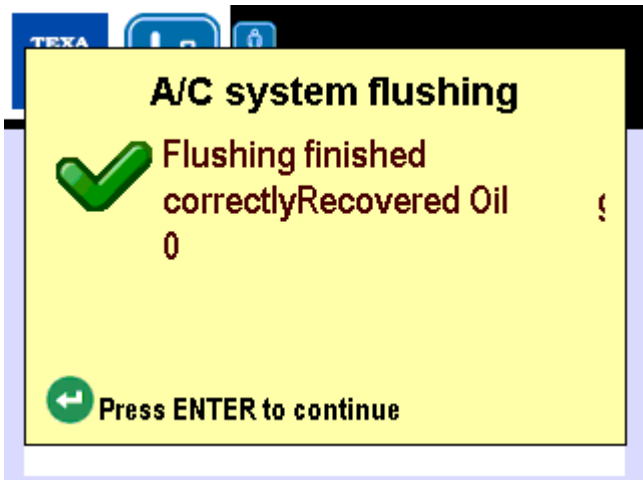

9.1 Alarm Notifications

In case of alarms, faults or need for maintenance, specific messages are displayed.

An audible warning sounds when these messages appear.

The message appears **during** the **recovery** phase if the temperature is high and/or the internal tank is at its pressure capacity limit.

Let it cool down for 30 minutes.

Press .

If the problem persists, contact **TEXA S.p.A.** or an authorised retailer.

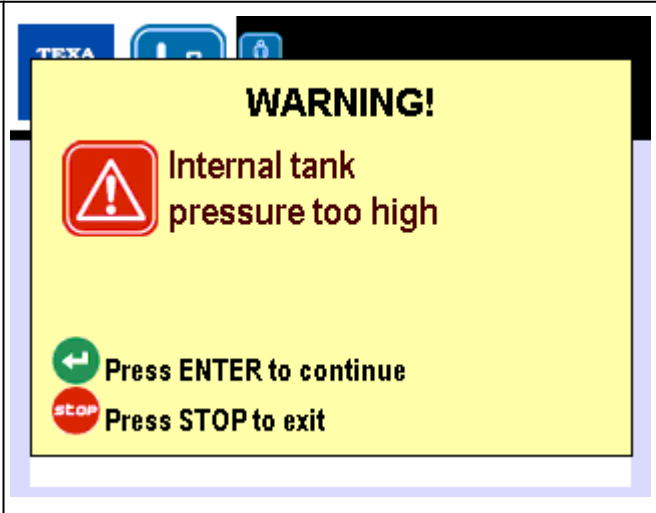

The message appears **at the beginning or during** the **vacuum** phase if pressure is detected inside the A/C system.

To exit, press .



The message appears **during** the **leak test** phase.

The vacuum value is indicated in mBar.

Check the A/C system.

Press  to continue.

Press  to exit.

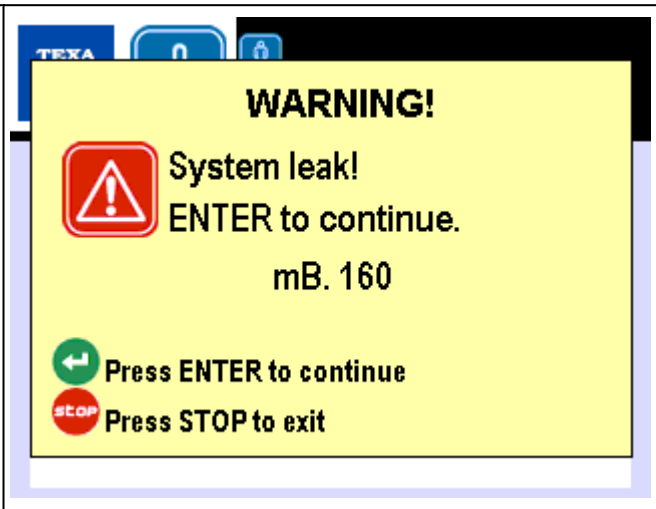

The amount of refrigerant is not enough for the cleaning.
Perform the Internal tank filling phase (refer to the charging station's technical manual).
Check the A/C system.

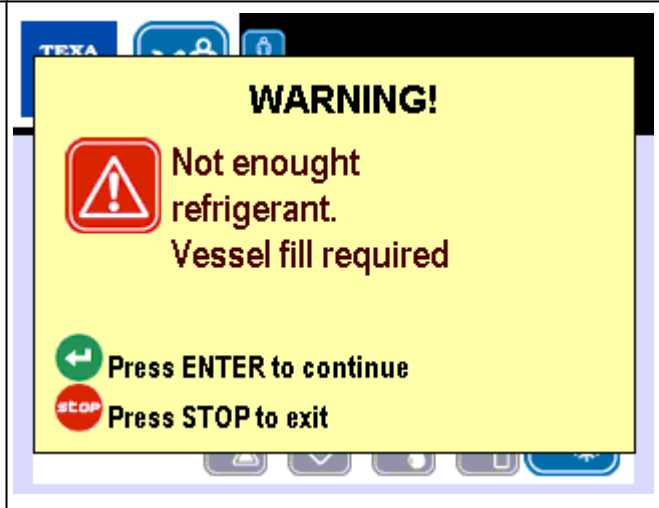

10 POST-CLEANING RECOMMENDATIONS

After cleaning a system, we recommend to proceed with some maintenance operations on the A/C system:

- *Replace all the system's O-rings.*
- *Replace the dryer filter or the accumulator.*
- *Discharge and replace the compressor oil.*
- *Reassemble the entire A/C system.*
- *Pressurise the system with nitrogen and check for leaks.*
- *Put the system under high-vacuum in order to remove the humidity.*
- *Inject the UV additive as a measure to prevent possible leaks.*
- *Reload the lubricant and the refrigerant as required by the manufacturer.*
- *Make sure the system works properly (noise, pressure, performances, leaks, etc.).*

11 MAINTENANCE

Following are the maintenance operations that must be carried out on the components of the flushing kit.

Refer to the charging station's technical manual for the maintenance operations related to the equipment.

11.1 Replacing the Dryer Filter of the Cleaning Vessel

Replace the dryer filter of the cleaning vessel periodically.



The dryer filter must be replaced every 10 single flushings or every 3 multiple cleanings (if the system is very dirty).



Do not remove the caps sealing the dryer filter before it is requested by the procedure.

Proceed as follows:

1. Turn off and disconnect the charging station.
2. Make sure the cleaning vessel does not contain refrigerant.

3. Remove the blue service pipe from the charging station.

4. Remove the coupler downstream of the dryer filter using the right sized wrench.



5. Remove the saturated dryer filter from the upstream coupler using the right sized wrench.



Carry out the operations below as quickly as possible, to prevent the deterioration of the dryer filter.

6. Remove the caps sealing the dryer filter.

7. Reinstall the dryer filter (code 3906914) on the upstream coupler.
8. Reconnect the coupler downstream of the dryer filter using the right sized wrench.

11.2 Internal Cleaning of the Cleaning Vessel

Clean the inside of the cleaning vessel periodically.



Protect eyes and hands from solid particles that could be ejected during the cleaning.

Proceed as follows:

1. Turn off and disconnect the charging station.
2. Make sure the cleaning vessel does not contain refrigerant.

3. Remove the chrome-plated cap at the bottom of the cleaning vessel.
4. Open the valve on the lower part of the cleaning vessel.



5. Clean by injecting compressed air in the vessel's input: the contaminations will be ejected through the hole.

We recommend to install a small container under the vessel that is capable of collecting the ejected contaminations.



6. Close the valve.
7. Put the chrome-plated cap back on.

12 ENVIRONMENTAL INFORMATION



For information regarding the disposal of this product please see the pamphlet supplied.

13 LEGAL NOTICES

TEXA S.p.A.

Via 1 Maggio, 9 - 31050 Monastier di Treviso - ITALY

Tax Code - Company Register of Treviso ID No. - VAT No.: 02413550266

Single-shareholder company subject to the direction and coordination activities of Opera Holding S.r.l.

Paid-up share capital 1,000,000 €- R.E.A. (Economic Administrative Index) No. 208102

Legal Representative Bruno Vianello

Phone +39 0422.791.311

Fax +39 0422.791.300

www.texa.com

For information regarding the legal notices, please refer to the **International Warranty Booklet** provided with the product.