

IN8231

Trade Van Racking - Single Unit

THANK YOU FOR PURCHASING A VAN GUARD TRADE VAN RACKING UNIT

TOOLS REQUIRED

TAPE MEASURE X1



SPANNER (10MM / M6) X 2



SPANNER (13MM / M8) X 2



DRILL (Ø8.5) X 1

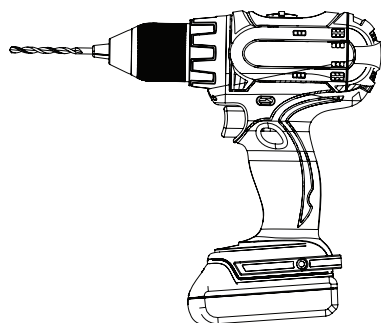

ONE PERSON



FITTING TIME
(APPROXIMATELY)



CAUTION



It is important that care is taken when drilling and fixing to your vehicle.

You should note that it is the responsibility of the installer/s to ensure that when drilling holes in to your vehicle to take fixings, care must be taken to ensure that the fuel line, tyres, fuel tank, wiring loom, exhaust, bodywork and brake lines etc. are not damaged.

If in doubt refer to the vehicle manufacturer's dealership.

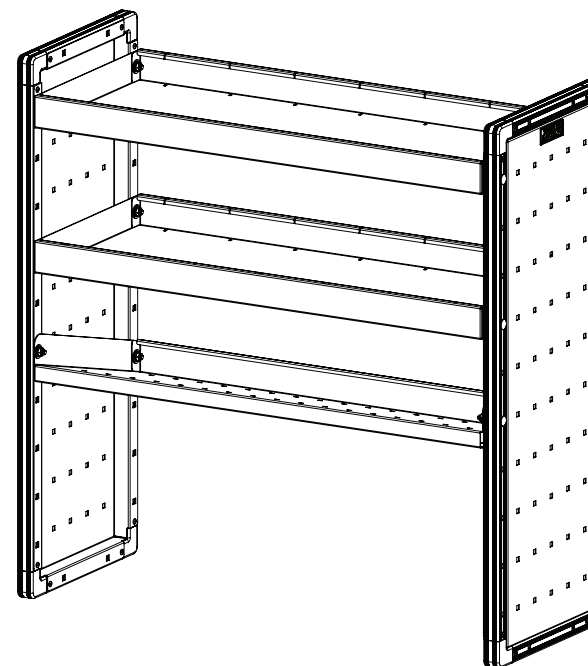

This FITTING INSTRUCTION is the property of VAN GUARD ACCESSORIES LTD. and must not be used for manufacturing purposes, copied nor communicated in any way to third parties without written permission from VAN GUARD ACCESSORIES LTD.

IN8231_B

Van Guard Accessories Ltd
Fair Oak Close, Exeter Airport Business Park,
Exeter, Devon, EX5 2UL
www.van-guard.co.uk



FAILURE TO TAKE NOTICE OF THE FOLLOWING INFORMATION MAY RESULT IN SERIOUS INJURY AND / OR DAMAGE TO THE VEHICLE.

1. You should note that it is the responsibility of the installer/s to ensure that when drilling holes in to your vehicle to take fixings, care must be taken to ensure that the fuel line, tyres, fuel tank, wiring loom, exhaust, bodywork and brake lines etc. are not damaged. If in doubt refer to the vehicle manufacturer's dealership.

2. When fitting the unit to the side of a vehicle we recommend that the fixing brackets are fixed to the inner steel skin of the vehicle. Fixing to a plywood lining alone is not adequate.

3. When fixing to the side of a vehicle, care should be taken to ensure there is sufficient room between the inner and outer skin, so as not to puncture the outer skin of the vehicle.

4. When drilling, use as short a drill bit as possible to prevent damaging the vehicle. Use corrosion protection when drilling.

5. Regularly inspect all fixings and parts. Any damaged or worn parts should be immediately removed the vehicle and replaced.

6. We recommend this product is only fitted to vehicles with a full bulkhead.

7. This product must be fixed in place, even if it is not to be fitted inside a vehicle.

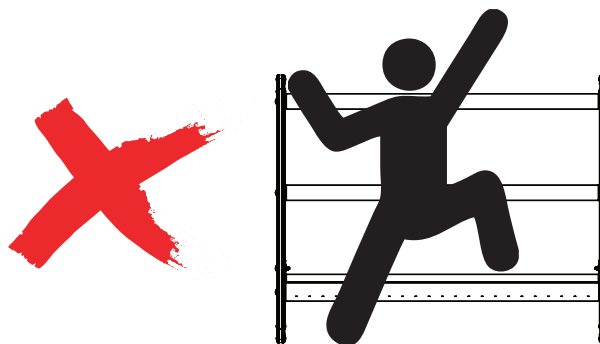

Do not climb or stand on the assembled unit.

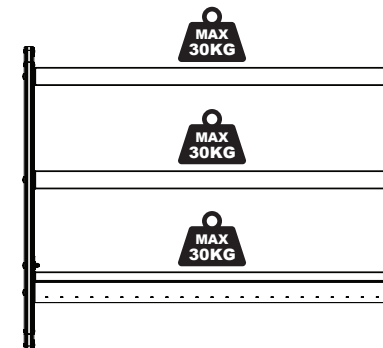

Do not exceed the maximum weight limit of 30KG per shelf.

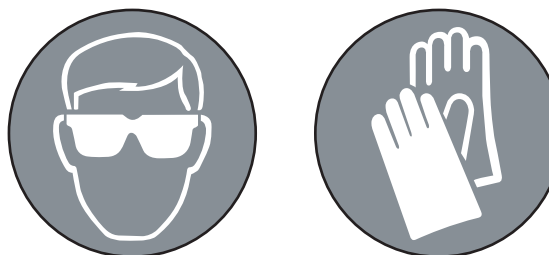

Wear the appropriate protective equipment (safety glasses & gloves) while fitting this product.

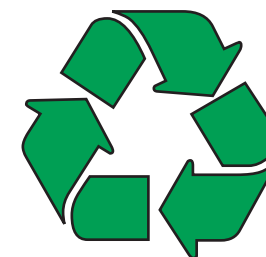

Dispose of packaging materials responsibly - Do not dispose until you have checked all parts and fixings are present.



Retain these fitting instructions for future reference.



It is important that the end user receives this instruction even if they are not the fitter.



WE ADVISE OPENING EACH FIXING KIT WHEN INSTRUCTED AT THE RELEVANT STEP

KT5447

SHELF FIXING KIT

FX4011 X4
(M8 FLANGE NUT)

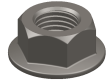

FX4040 X4
(M8 WASHER)



FX4138 X4
(M8X50 COACH BOLT - BLACK)



ME0918 X2



ME0919 X4

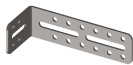

ME0920 X2



KT5449

FIXING KIT A

FX4002 X6
(M8 NYLOC NUT)



FX4011 X4
(M8 FLANGE NUT)



FX4040 X16
(M8 WASHER)



FX4048 X4
(M8X50 COACH BOLT)

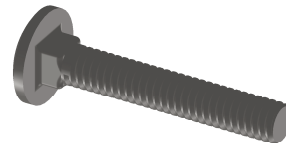

FX4140 X6
(M8X50 HEX BOLT)

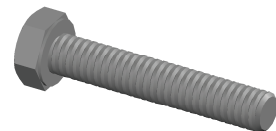

KT5450

FIXING KIT B

FX4011 X8
(M8 FLANGE NUT)

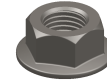

FX4040 X8
(M8 WASHER)



FX4048 X4
(M8X50 COACH BOLT)

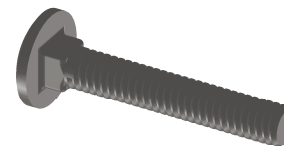

FX4141 X4
(M8X16 COACH BOLT)

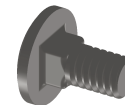

KT5451

FIXING KIT C

FX4013 X8
(M6 WASHER)



FX4016 X8
(M6 FLANGE NUT)



FX4040 X8
(M8 WASHER)



FX4061 X8
(M6X14 HEX BOLT)

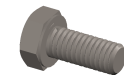

FX4142 X8
(No14 3/4" SELF TAP SCREW)

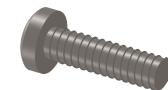



SHELF FIXING METHOD (PAGE 1 OF 1)

1.1 Open KT5447 (shelf fixing kit) - This fixing kit will be packed in the same box as the shelves (one fixing kit per shelf) and will provide the fixings required to assemble the shelves to the side panels. See page three for the parts included in this fixing kit.



WE ADVISE OPENING EACH FIXING KIT WHEN INSTRUCTED AT THE RELEVANT STEP

KT5447 SHelf FIXING KIT	KT5449 FIXING KIT A	KT5450 FIXING KIT B	KT5451 FIXING KIT C
FX4011 X4 (M8 FLANGE NUT)	FX4002 X5 (M8 W/Lock NUT)	FX4011 X8 (M8 FLANGE NUT)	FX4013 X8 (M8 FLANGE NUT)
FX4040 X4 (M8 FLANGE NUT)	FX4011 X4 (M8 FLANGE NUT)	FX4040 X5 (M8 FLANGE NUT)	FX4016 X5 (M8 FLANGE NUT)
FX1138 X4 (M8x10 COACH BOLT - BLACK)	FX4040 X16 (M8 FLANGE NUT)	FX4048 X4 (M8x10 COACH BOLT)	FX4040 X8 (M8 FLANGE NUT)
ME0918 X2	FX4048 X4 (M8x10 COACH BOLT)	FX4113 X4 (M8x10 COACH BOLT)	FX4081 X8 (M8x10 FLG NUT)
ME0919 X4	FX4140 X5 (M8x10 FLG BOLT)		FX4142 X8 (M8x10 FLG BOLT)
ME0920 X2			

IN8231 - PAGE 3 OF 8

1.2 Loosely secure the shelves to the side panels using M8x50 coach bolts, M8 washers and M8 flange nuts.

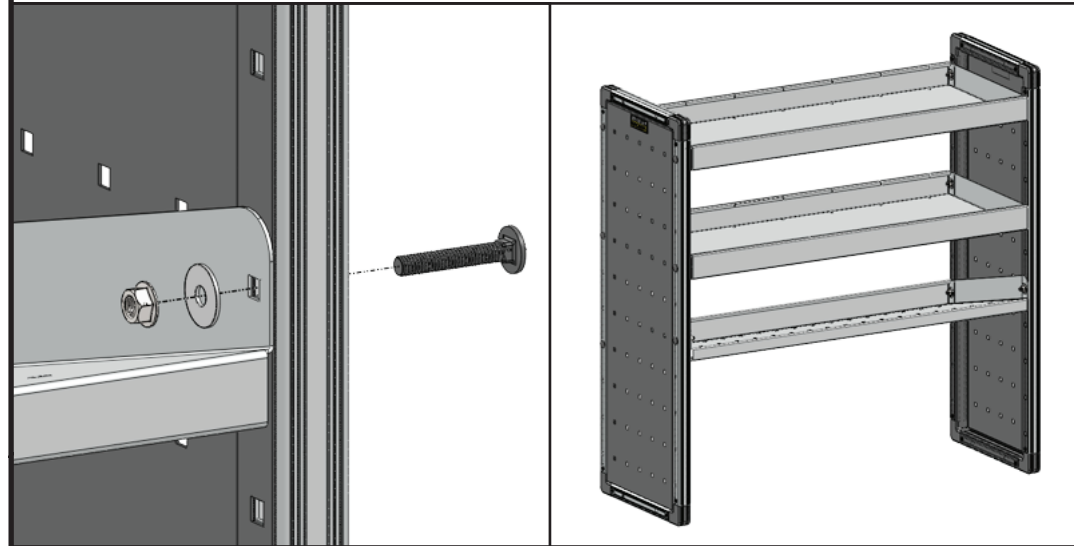

1.3 Ensure the assembled unit is on a flat surface prior to tightening the fixings.

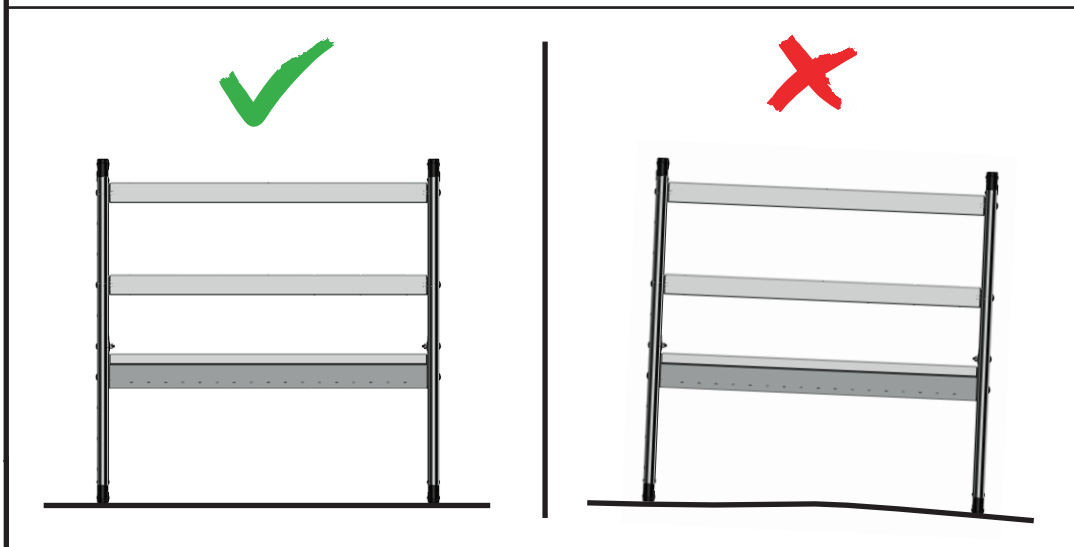

1.4 Tighten all fixings to 5Nm. Take care not to damage the unit by over tightening the fixings.

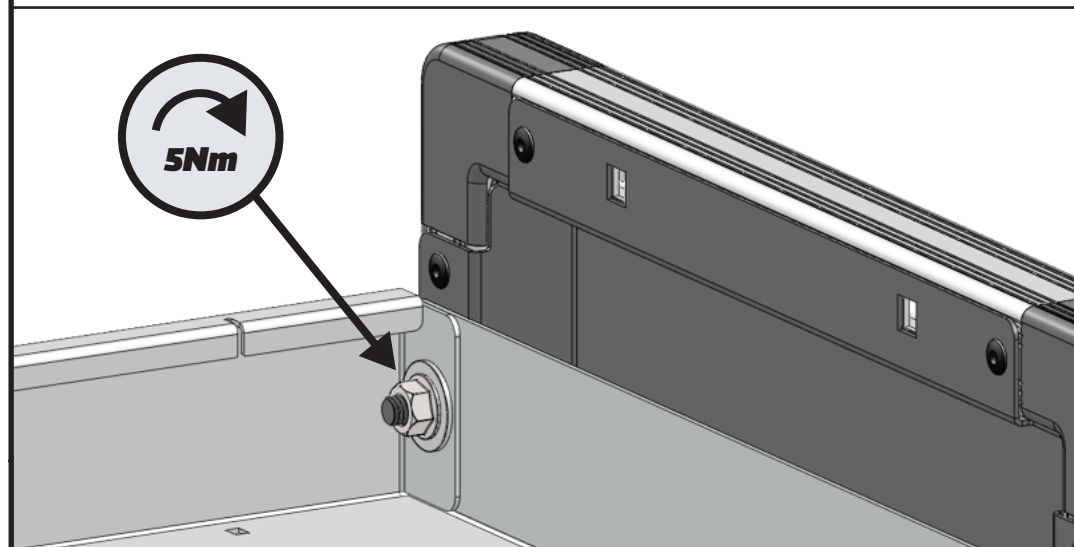



RECOMMENDED FLOOR FIXING METHOD (PAGE 1 OF 2)

2.1 The following steps list our recommended method for fixing the racking unit to the floor of a vehicle. **Prior to proceeding past this point please take the time to read through the important notes on page two.**

PLEASE TAKE THE TIME TO READ THROUGH THE IMPORTANT INFORMATION BELOW BEFORE PROCEEDING TO FIT THIS PRODUCT

FAILURE TO TAKE NOTICE OF THE FOLLOWING INFORMATION MAY RESULT IN SERIOUS INJURY AND / OR DAMAGE TO THE VEHICLE.

- You should note that it is the responsibility of the installer to ensure that when drilling holes in to your vehicle to take fixings, care must be taken to ensure that the fuel line, tyres, fuel tank, wiring loom, exhaust, bodywork and brake lines etc. are not damaged. If in doubt refer to the vehicle manufacturer's dealership.
- When fitting the unit to the side of a vehicle we recommend that the fixing brackets are fixed to the inner steel skin of the vehicle. Fixing to a plywood lining alone is not adequate.
- When fixing to the side of a vehicle, care should be taken to ensure there is sufficient room between the inner and outer skin, so as not to puncture the outer skin of the vehicle.
- When drilling, use as short a drill bit as possible to prevent damaging the vehicle. Use corrosion protection when drilling.
- Regularly inspect all fixings and parts. Any damaged or worn parts should be immediately removed the vehicle and replaced.
- We recommend this product is only fitted to vehicles with a full mainbeam.
- This product must be fixed in place, even if it is not to be fixed inside a vehicle.

Do not climb or stand on the assembled unit

Do not exceed the maximum weight limit of 30KG per shelf

Wear the appropriate protective equipment (safety glasses & gloves) while fitting this product.

Dispose of packaging materials responsibly - Do not dispose until you have checked all parts and fixings are present.

Retain these fitting instructions for future reference.

It is important that the end user receive this instruction even if they are not the fitter.

IN8231 - PAGE 2 OF 8

2.2 Open KT5449 (fixing kit A) - This fixing kit will provide the fixings to fix the unit to the floor of a vehicle. See page three for the parts included in this fixing kit.



WE ADVISE OPENING EACH FIXING KIT WHEN INSTRUCTED AT THE RELEVANT STEP

KT5447 FIXING KIT A	KT5449 FIXING KIT A	KT5450 FIXING KIT B	KT5451 FIXING KIT C
FX4011 X4 (PER FLANGE NUT)	FX4002 X6 (PER FLANGE NUT)	FX4011 X6 (PER FLANGE NUT)	FX4013 X8 (PER FLANGE NUT)
FX4040 X4 (PER WASHER)	FX4011 X4 (PER FLANGE NUT)	FX4040 X6 (PER WASHER)	FX4016 X6 (PER FLANGE NUT)
FX4138 X4 (M8x50 COACH BOLT) (BLACK)	FX4040 X16 (PER WASHER)	FX4048 X4 (M8x50 COACH BOLT)	FX4040 X6 (PER WASHER)
ME0918 X2	FX4048 X4 (M8x50 COACH BOLT)	FX4113 X4 (PER WASHER)	FX4061 X8 (M8x50 COACH BOLT)
ME0919 X4	FX4140 X6 (M8x50 HEX BOLT)		FX4142 X8 (M8x50 SELF TAP SCREW)
ME0920 X2			

IN8231 - PAGE 3 OF 8

2.3 Secure the floor brackets (ME0918) to the side panels using M8x50 coach bolts, M8 washers and M8 flange nuts. Tighten to 5Nm. **Take care not to damage the unit by over tightening the fixings.**

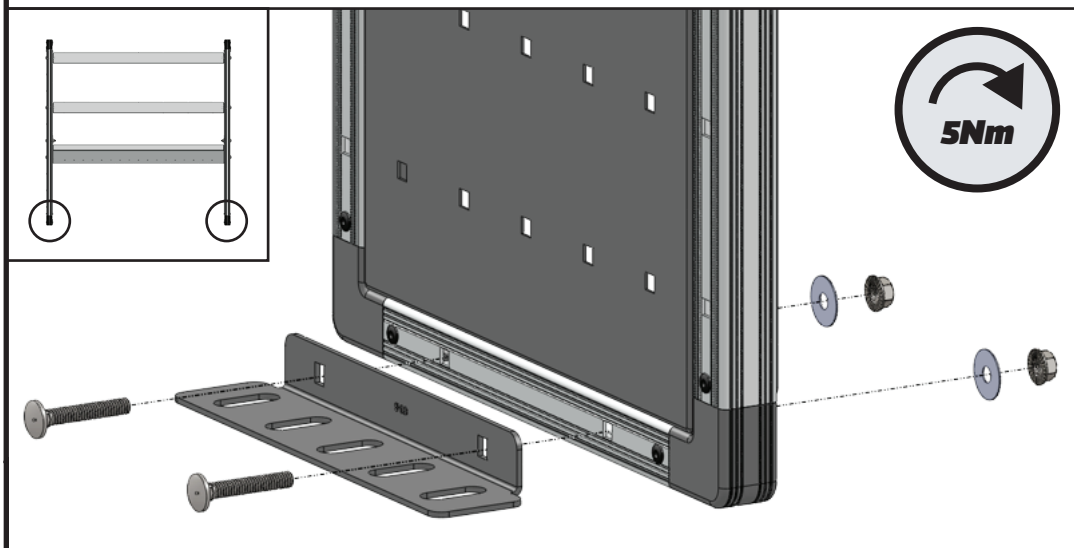

2.4 Position the unit inside the vehicle in desired position.

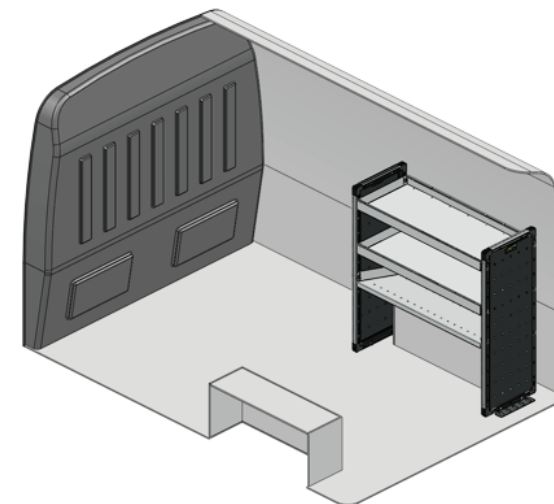



2.5



CAUTION



It is important that care is taken when drilling and fixing to your vehicle.

You should note that it is the responsibility of the installer/s to ensure that when drilling holes in to your vehicle to take fixings, care must be taken to ensure that the fuel line, tyres, fuel tank, wiring loom, exhaust, bodywork and brake lines etc. are not damaged.

If in doubt refer to the vehicle manufacturer's dealership.

2.6

Measure from the side and rear of the vehicle and note down the positions of the floor brackets. Use the same measurements underneath the vehicle to check that the underside is clear of any obstructions so drilling can take place.

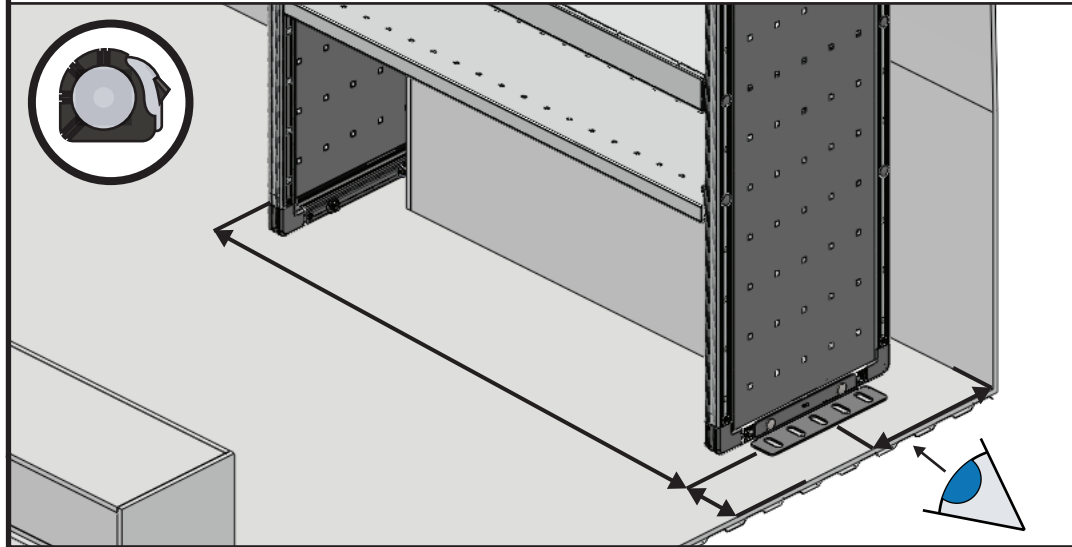

2.7

After ensuring the area under the floor bracket / vehicle floor is free from obstruction, mark the hole centres of the fixing slots. Move the unit to one side and drill Ø8.5mm through the floor of the vehicle (three positions for each bracket).

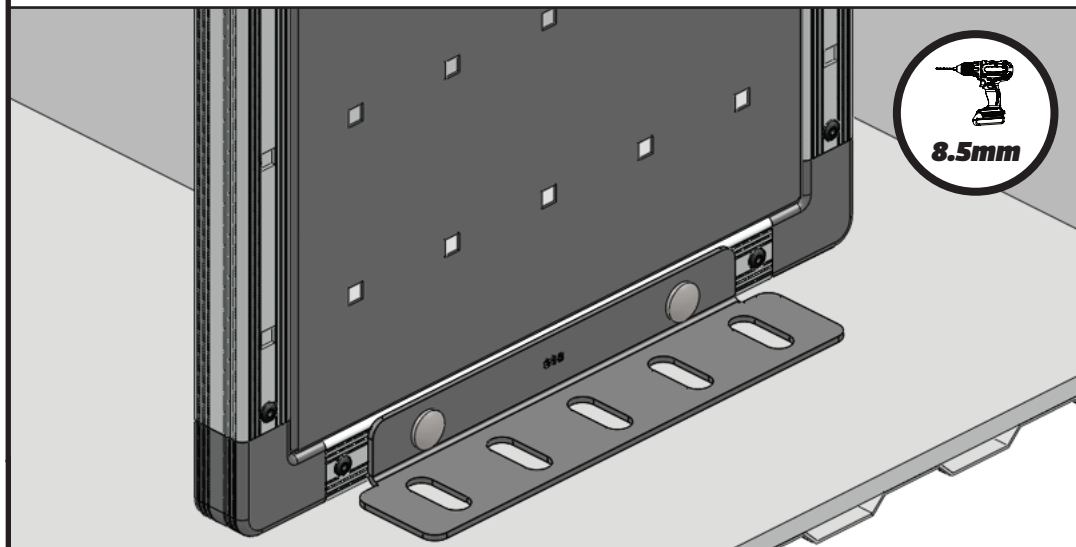

2.8

Bolt down through the floor brackets using M8x50 hex bolts and M8 washers, secure underneath the vehicle using M8 washers and M8 nyloc nuts.

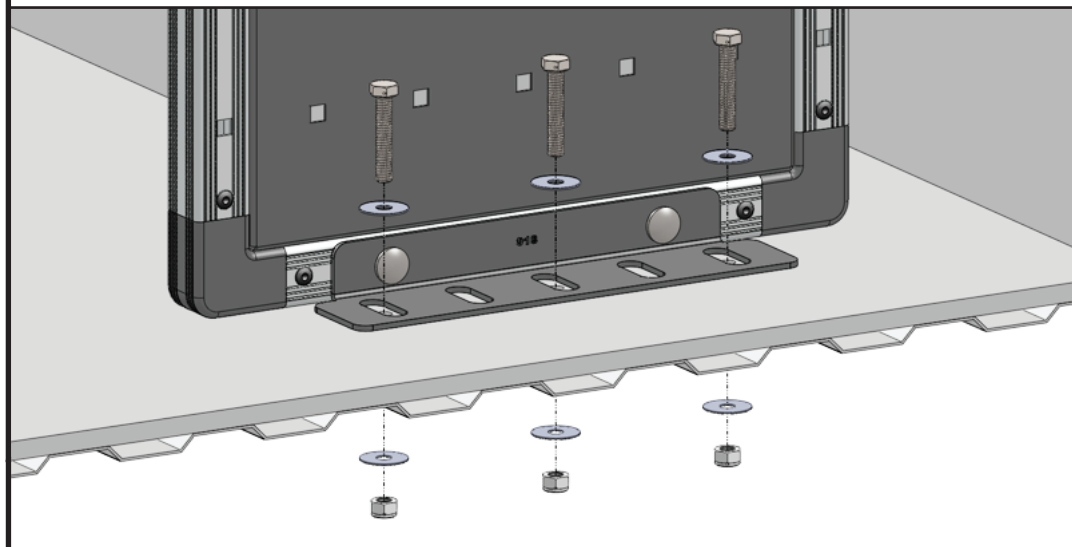



RECOMMENDED SIDE FIXING METHOD (PAGE 1 OF 2)

3.1 The following steps list our recommended method for fixing the racking unit to the side of a vehicle. **Prior to proceeding past this point please take the time to read through the important notes on page two.**

PLEASE TAKE THE TIME TO READ THROUGH THE IMPORTANT INFORMATION BELOW BEFORE PROCEEDING TO FIT THIS PRODUCT

FAILURE TO TAKE NOTICE OF THE FOLLOWING INFORMATION MAY RESULT IN SERIOUS INJURY AND / OR DAMAGE TO THE VEHICLE.

- You should note that it is the responsibility of the installer to ensure that when drilling holes in to your vehicle to take fixings, care must be taken to ensure that the fuel line, tyres, fuel tank, wiring loom, exhaust, bodywork and brake lines etc. are not damaged. If in doubt refer to the vehicle manufacturer's dealership.
- When fitting the unit to the side of a vehicle we recommend that the fixing brackets are fixed to the inner steel skin of the vehicle. Fixing to a plywood lining alone is not adequate.
- When fixing to the side of a vehicle, care should be taken to ensure there is sufficient room between the inner and outer skin, so as not to puncture the outer skin of the vehicle.
- When drilling, use as short a drill bit as possible to prevent damaging the vehicle. Use corrosion protection when drilling.
- Regularly inspect all fixings and parts. Any damaged or worn parts should be immediately removed the vehicle and replaced.
- We recommend this product is only fitted to vehicles with a full bulkhead.
- This product must be fixed in place, even if it is not to be fitted inside a vehicle.

Do not climb or stand on the assembled unit.

Do not exceed the maximum weight limit of 35KG per shelf.

Wear the appropriate protective equipment (safety glasses & gloves) while fitting this product.

Dispose of packaging materials responsibly - Do not dispose until you have checked all parts and fixings are present.

Retain these fitting instructions for future reference.

It is important that the end user receive this instruction even if they are not the fitter.

IN8231 - PAGE 2 OF 8

3.2 Open KT5450 (fixing kit B) & KT5451 (fixing kit C) - These fixing kits will provide the fixings to fix the unit to the side of a vehicle. See page three for the parts included in these fixing kits.



WE ADVISE OPENING EACH FIXING KIT WHEN INSTRUCTED AT THE RELEVANT STEP

KT5447 FIXING KIT A	KT5449 FIXING KIT B	KT5450 FIXING KIT C	KT5451 FIXING KIT D
FX4011 X4 (PER FLANGE NUT)	FX4002 X6 (PER W/LOC NUT)	FX4011 X6 (PER FLANGE NUT)	FX4013 X8 (PER NUT)
FX4040 X4 (PER NUT)	FX4011 X4 (PER FLANGE NUT)	FX4040 X6 (PER NUT)	FX4016 X6 (PER FLANGE NUT)
FX4138 X4 (M8X50 COACH BOLT) (BLACK)	FX4040 X16 (PER NUT)	FX4048 X4 (M8X50 COACH BOLT)	FX4040 X6 (PER NUT)
ME0918 X2	FX4048 X4 (M8X50 COACH BOLT)	FX4113 X4 (M8X50 COACH BOLT)	FX4061 X8 (PER NUT)
ME0919 X4	FX4140 X6 (M8X16 HEX BOLT)		FX4142 X8 (M8X16 SELF TAP SCREW)
ME0920 X2			

IN8231 - PAGE 3 OF 8

3.3 Each side panel requires 2x fixing brackets as shown in FIG.1. Secure the fixing brackets (ME0919) to the unit in the required positions using M8x50 coach bolts, M8 washers and M8 flange nuts as shown in FIG.2. **Take care not to damage the unit by over tightening the fixings.** Ensure the fixing brackets are positioned to pick up on the inner steel skin of the vehicle and are not against the outer skin. If required an extension bracket can be used as shown in FIG.3.

FIG.1

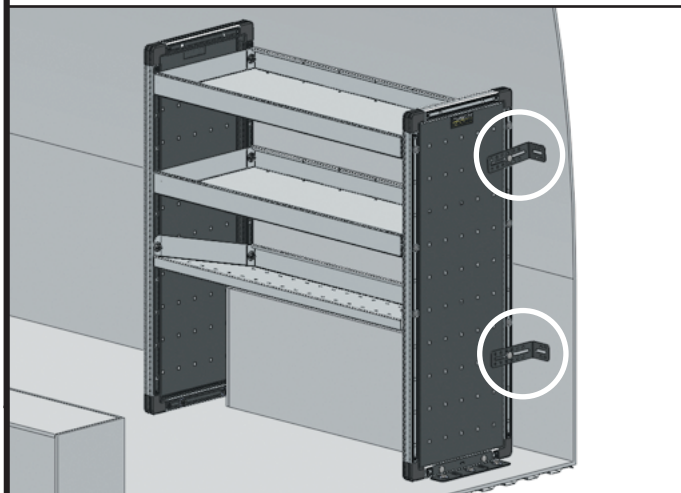

FIG.2

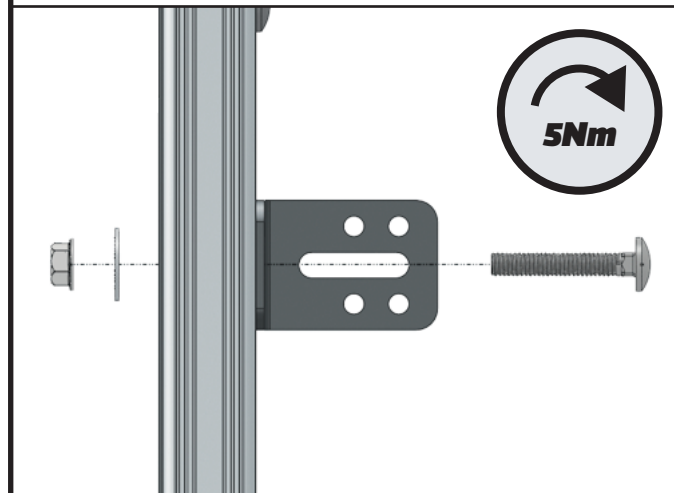
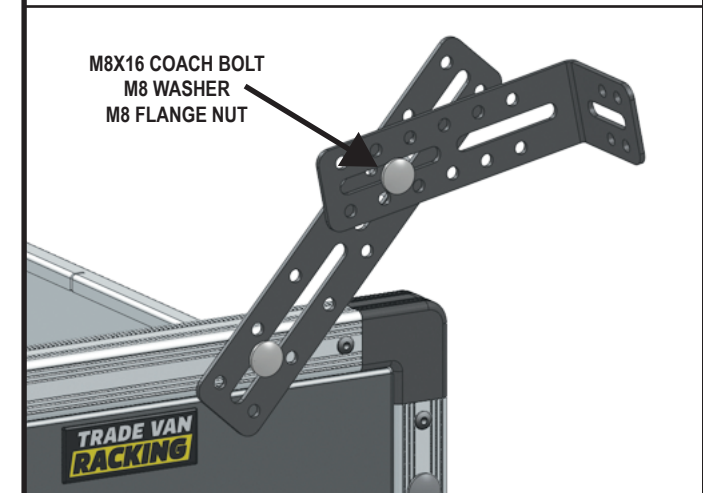

FIG.3





3.4



CAUTION



It is important that care is taken when drilling and fixing to your vehicle.

You should note that it is the responsibility of the installer/s to ensure that when drilling holes in to your vehicle to take fixings, care must be taken to ensure that the fuel line, tyres, fuel tank, wiring loom, exhaust, bodywork and brake lines etc. are not damaged.

If in doubt refer to the vehicle manufacturer's dealership.

3.5

Check the positions behind the fixing brackets are free from obstruction (wiring looms / electrical wires etc.). Once checked carefully drill through the fixing bracket holes using a suitable drill bit for the fixing.

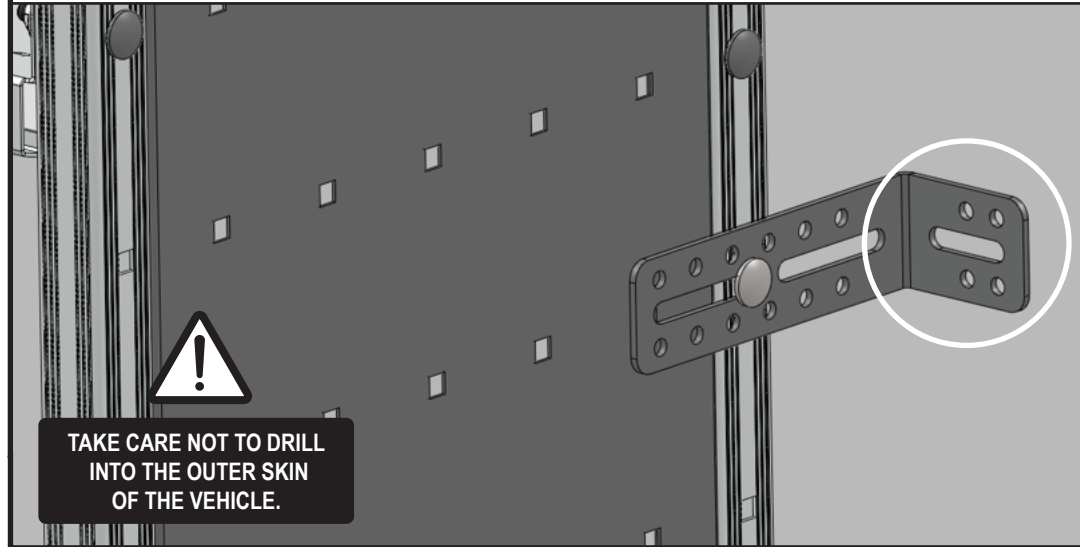

3.6

Secure the fixing brackets to the side of the vehicle using M6x14 hex bolts, M6 washers and M6 flange nuts.

