

VDO E-Gas[®] Set-Point Sender

Order- No. 445-804-005-014



Contents	Page
1. General Data	3
1.1 <i>Purpose</i>	3
1.2 <i>Block circuit diagram</i>	3
1.3 <i>Description of structure and function</i>	3
2. Operating Conditions	4
3. Mechanical Data	4
3.1 <i>Actuation angle</i>	4
3.2 <i>Torque values (for actuation towards full load)</i>	4
3.3 <i>Forces</i>	4
4. Electrical Data	5
4.1 <i>Terminal assignment</i>	5
4.2 <i>Potentiometer</i>	5
4.3 <i>Operating range of the set-point sender as a voltage-divider ratio</i>	5
4.4 <i>Voltage-divider ratio at the safety-contact switching point</i>	5
4.5 <i>Safety contact</i>	5
5. Qualification / Service-Life Test	6
5.1 <i>Combined temperature, climate and endurance test</i>	6
5.1.1 <i>Actuation cycles</i>	6
5.1.2 <i>Temperature cycle during the service-life test</i>	6
5.1.3 <i>Monitoring during the test</i>	6
5.2 <i>Storage-temperature test</i>	7
5.3 <i>Vibration test</i>	7
5.4 <i>Protection-type test</i>	7
5.5 <i>Corrosion test</i>	7
5.5.1 <i>Salt-spray test</i>	7
5.5.2 <i>Industrial atmosphere</i>	7
5.5.3 <i>Damp-heat alternating atmosphere</i>	7
5.6 <i>Insulation test</i>	7

1. General Data

1.1 Purpose

The set-point sender is used as an accelerator-pedal position sender as part of a VDO E-Gas® system.

1.2 Block circuit diagram

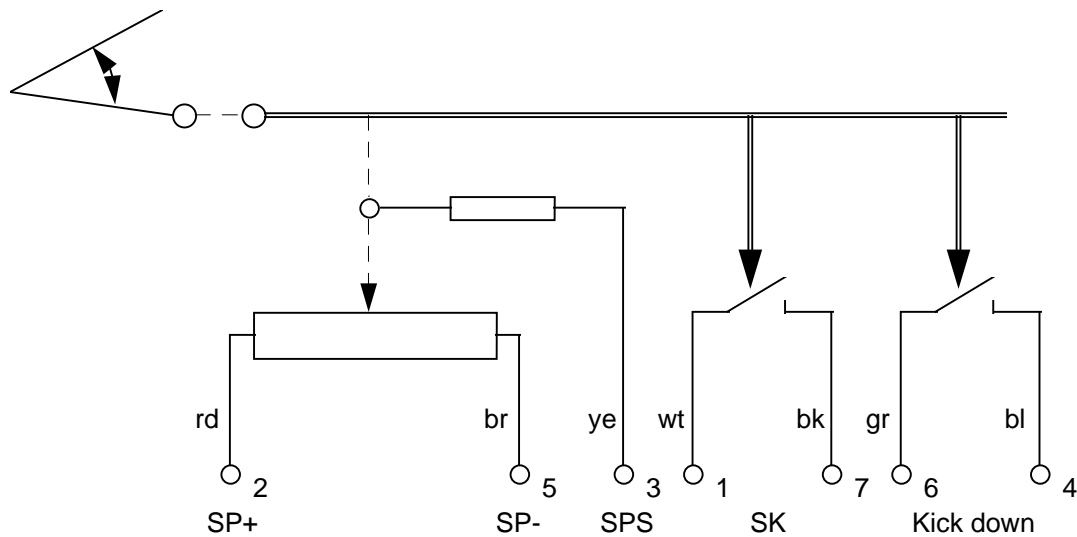

Figure: Block circuit diagram of VDO E-Gas® set-point sender in idling position.

1.3 Description of structure and function

The set-point sender converts the accelerator-pedal position into an electrical signal using a potentiometer. The potentiometer slider is linked to the drive lever via the potentiometer and drive shaft by means of a positive connection. The potentiometer casing is secured to the aluminum casing by means of a friction-type connection. The set-point signal is available at all times.

A switching contact is actuated within a defined range. The safety contact (SK) has a fixed relation to a potentiometer value. The actuation cam is connected to the drive shaft by means of a positive connection. When the drive lever is moved from full load to idling, the safety contact is forced open. The contact spring is designed to last for the full service life.

2. Operating Conditions

Operating temperature	-40°C to +80°C
Storage temperature	-40°C to +90°C
Protection class	IP 66

The set-point sender is designed for frame mounting with respect to ambient temperature, vibration strength and protection class.

3. Mechanical Data

3.1 Actuation angle

Adjustment angle	$73^\circ \pm 2^\circ$
Direction of rotation	Anti clockwise from a plan view of the drive axle
Position of the pivot of the output axle with elec. zero	$48^\circ + 2^\circ / - 1^\circ$ relative to securing plane
Full-load point	$60^\circ \pm 2^\circ$
Kickdown	$2^\circ + 4^\circ$ after full load
Switching point of safety contact	$3^\circ \pm 2^\circ$ relative to idling position

3.2 Torque values (for actuation towards full load)

Initial torque	160 Ncm + 20 / - 30 Ncm
Final torque	280 Ncm \pm 40 Ncm
Kickdown torque	550 Ncm \pm 70 Ncm
Hysteresis	mechanical start 50 Ncm \pm 20 Ncm
	mechanical end 50 Ncm \pm 20 Ncm

At temperatures below -20°C, an increase in hysteresis is possible, but the reset to idling is guaranteed.

Maximum theoretical bearing load on adjustment lever

Dynamic	500 N
Static	1000 N

Note: The set-point sender is not designed for use of the internal full-load stop. As a result of the force support of the adjustment torque between the full-load stop and the bearings, an excessive bearing load may occur. An external full-load stop is therefore required.

3.3 Forces

Pull-out strength of the cable	> 80 N
--------------------------------	--------

4. Electrical Data

4.1 Terminal assignment

See client drawing.

4.2 Potentiometer

Rated resistance	1.4 k Ω + 100% / - 25%
Slider protective resistance	1.5 k Ω \pm 30%
Linearity (absolute)	\pm 2%
Resistance value in the slider line without slider protective resistor	300 Ω (when new) max. 10 k Ω (throughout service- life test)
Slider current of the potentiometer	2 mA stat. max. \leq 15 μ A during operation
Max. potentiometer voltage	$U_{o \max.} = 10$ V
Voltage strength	for max. 1 hour at room temperature and $U_{\max} = 30$ V if the over voltage is between two terminal pins.

Note: After an incorrect connection the slider may be moved over the resistance for a maximum of two seconds.

4.3 Operating range of the set-point sender as a voltage-divider ratio

Electrical zero position (LL)	$U_s/U_o = 0.045 - 0.053$	corresponding to 0°
Full load	$U_s/U_o = 0.5367 - 0.6377$	corresponding to 60° \pm 2°
Maximum lever travel	$U_s/U_o = \max. 0.7350$	corresponding to max. 75°

4.4 Voltage-divider ratio at the safety-contact switching point

Mechanical angle relative to electrical zero position	from 1° to 5°
Voltage-divider ratio	$U_s/U_o = 0.0715 - 0.0835$

4.5 Safety contact

Minimum switching current	$I_{s \min} = 5$ mA; non inductive
Maximum switch current	$I_{s \max} = 1$ A; non inductive

5. Qualification / Service-Life Test

5.1 Combined temperature, climate and endurance test

5.1.1 Actuation cycles

The actuation process is to be completed mechanically using the set-point sender.

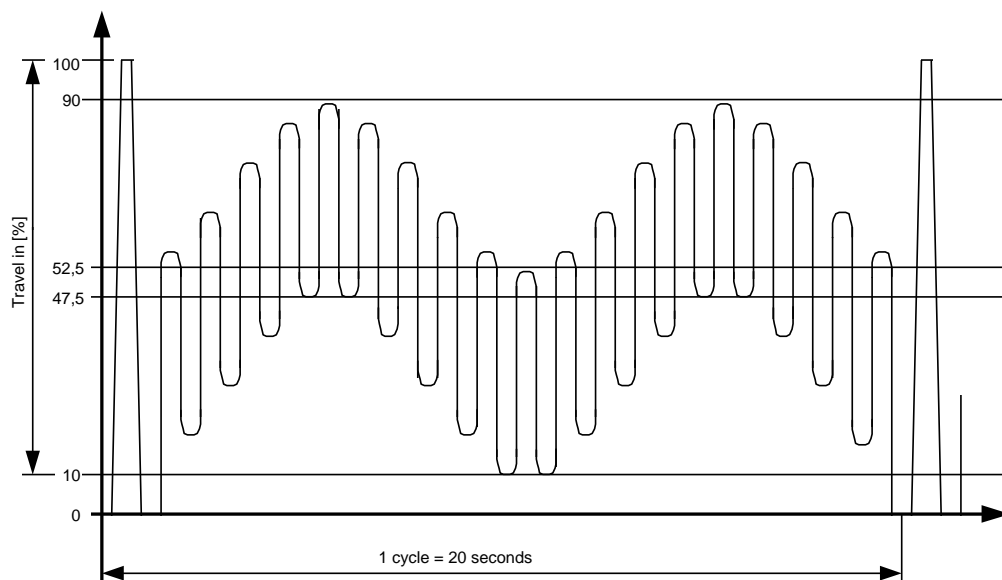

- $5 \cdot 10^5$ Cycles at the full-load point up to 100% angle of rotation
- 10^6 Cycles at the idling point down to 0% angle of rotation
- 10^7 Superimposed load cycle 42.5% angle of rotation within a range of 10% to 90% angle of rotation

5.1.2 Temperature cycle during the service-life test

- 10% of stroke reversals at -40°C
- 40% of stroke reversals at +80°C
- 20% of stroke reversals at temperature changes over 6 hours each at 80°C and -40°C
- 10% of stroke reversals at +40°C and 90% relative humidity
- 20% of stroke reversals at room temperature

Temperature = cabinet temperature
Temperature gradient approximately 1°C/min.

5.1.3 Monitoring during the test

Safety circuits must not trip during the test.

5.2 Storage-temperature test

24 hours:	Store at -40°C.
6 hours:	Store at room temperature, then conduct function test.

5.3 Vibration test

Acceleration	1 g from 10 Hz to 500 Hz
Frequency changes	1 octave/min.
Test duration	48 hours per room level
Other details	Test at room temperature
Move the lever from 20% to 80% of the total angle	

5.4 Protection-type test

Protection class	IP 66 to DIN 40050
Not applicable to terminal plug.	

5.5 Corrosion test

5.5.1 Salt-spray test

In accordance with DIN 50021-SS over a period of 144 hours.

5.5.2 Industrial atmosphere

In accordance with DIN EN ISO 6988 over 6 cycles.

5.5.3 Damp-heat alternating atmosphere

In accordance with DIN 50017-KWF over 18 cycles.

5.6 Insulation test

Test as set out in QPV 01.18-01.