

Ändring	Revision	Datum	Date	Namn	Name
Introducerad	Introduced	2020	11 15	GORSTE	
Paustid ändrad	Delay time changed				
Impulstid införd	Impulse time added	2020	11 15	GORSTE	

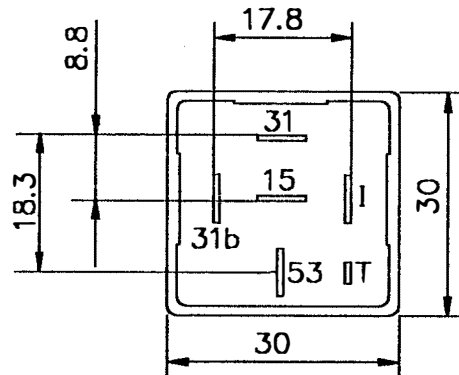

Inkopplingsexempel *Connection example*

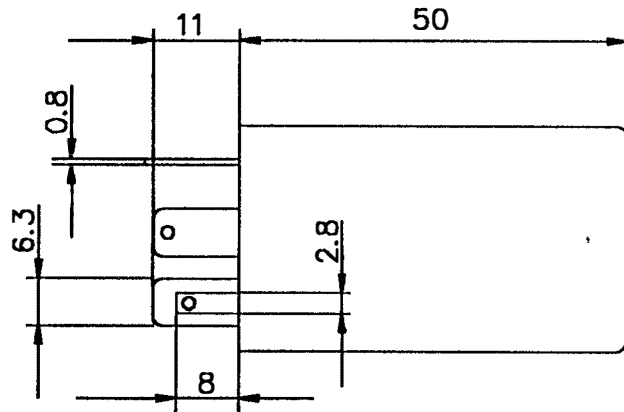
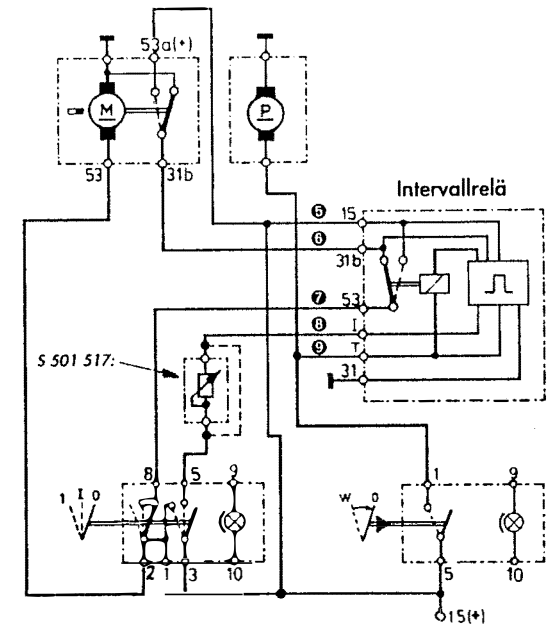

Arbetstemperatur	<i>Operating temperature</i>	-40°C -- +80°C
Intervalltorkning	<i>Intermittent wipe</i>	1 torkcykel 1 wipe cycle
Torkning efter spoln.	<i>Wipe-dry</i>	4 s ± 1 s
Paustid variabel	<i>Delay time variable</i>	2 s ± 1 s -- 8 s ± 2 s
Impulstid	<i>Impulse time</i>	0,5 s ± 0,1 s
Nominell spänning	<i>Nominal voltage</i>	24 V
Driftspänning	<i>Operating voltage</i>	21 V -- 32 V
Kapslingsklass	<i>Enclosure class</i>	IP 52

Ersätter <i>Replaces</i>		Material <i>Material</i>	Ytbehandling <i>Surface treatment</i>
Ritad <i>Drawn</i>	2020 11 15	TOLERANSER där ej annat angivits <i>TOLERANCES unless otherwise specified</i>	Diametrar enligt <i>Diameters as per</i>
Kontrollerad <i>Checked</i>	GORSTE	Övriga längdmått <i>Other dimensions</i>	Ytjämnhet <i>Surface quality</i>
Godkänd <i>Approved</i>	GORSTE	Benämning <i>Title</i>	
Projektion <i>Projection</i>		INTERVALLRELÄ TIMING CONTROL RELAY	
	Skala <i>Scale</i>	1:1	Artikelnummer <i>Article No.</i>
			S 601 668