

# H Installation documentation

Climate control "Webasto Comfort" for water heater Thermo Top Evo

BMW 1 Series (F20/F21) / 2 Series (F22/F23) / 2 Series Active Tourer (F45) / 2 Series Gran Tourer (F46) / 3 Series (F30/F31/F34) / 4 Series (F32/F36) / X1 (F48) / X2 (F39)

Mini (F55/F56/F57)

Left-hand drive vehicle

Manufacturer	Model	Type	Model year	EG-BE-No. / ABE
BMW	1 Series	F20/F21	from 2015	e1* 2007/46* 0283*...
BMW	2 Series	F22/F23	from 2015	e1* 2007/46* 0277*...
BMW	2 Series Active Tourer / Gran Tourer	F45/F46	from 2016	e1* 2007/46* 0371*...
BMW	2 Series Active Tourer	F45	from 2018	e1* 2007/46* 1675*...
BMW	3 Series	F30/F31	from 2015	e1* 2007/46* 0315*...
BMW	3 Series Gran Turismo	F34	from 2015	e1* 2007/46* 0559*...
BMW	4 Series	F32/F36	from 2015	e1* 2007/46* 0316*...
BMW	X1	F48	from 2016	e1* 2007/46* 0371*...
BMW	X1	F48	from 2017	e1* 2007/46* 1676*...
BMW	X2	F39	from 2018	e1* 2007/46* 1824*...
Mini	3-door	F56	from 2016	e1* 2007/46* 0371*...
Mini	3-door	F56	from 2021	e1* 2007/46* 1678*...
Mini	5-door	F55	from 2014	e1* 2007/46* 0371*...
Mini	5-door	F55	from 2021	e1* 2007/46* 1680*...
Mini	Convertible	F57	from 2016	e1* 2007/46* 0371*...
Mini	Convertible	F57	from 2018	e1* 2007/46* 1679*...

Validity	Equipment variants	Model							
		BMW						Mini	
		1 Series	2 Series	3 Series	4 Series	X1	X2	3-door 5-door	Convertible
Verified equipment variants	Manual air conditioning	---	---	---	---	---	---	x	---
	2 zone automatic air-conditioning	x	x	x	x	x	x	x	x

---

# Contents

<b>1</b>	<b>List of abbreviations</b>	<b>3</b>
<b>2</b>	<b>Installation notes</b>	<b>4</b>
2.1	Information on Validity	4
2.2	Components used	4
2.3	Validity Notes	5
<b>3</b>	<b>About this document</b>	<b>6</b>
3.1	Purpose of the document	6
3.2	Warranty and liability	6
3.3	Safety	6
3.4	Using this document	7
<b>4</b>	<b>Technical Information</b>	<b>8</b>
<b>5</b>	<b>Preparations</b>	<b>9</b>
5.1	Vehicle preparation	9
<b>6</b>	<b>Installation overviews</b>	<b>10</b>
<b>7</b>	<b>Electrical system</b>	<b>12</b>
7.1	Electrical system preparation	12
7.2	Glove box dismantling instructions (1 Series / 2 Series (F22/F23)/3 Series /4 Series only)	12
7.3	Wiring diagram	14
7.4	Fan controller of BMW 2 Series (F45/F46) / X1(F48) / X2(F39)	16
7.5	Fan controller of BMW 1 Series (F20/F21)/ 2 Series (F22/F23)/ 3 Series (F30/F31/F34)/ 4 Series (F32/F36)	18
7.6	Fan controller of Mini (F55/F56/F57)	21
7.7	Connecting same colour wires of wiring harnesses, all vehicles	24
<b>8</b>	<b>Final work</b>	<b>25</b>
<b>9</b>	<b>Operating instructions</b>	<b>27</b>
9.1	Installation location of fuses for BMW 2 Series (F45/F46) / X1(F48) / X2 (F39)	27
9.2	Installation location of fuses for BMW 1 Series (F20/F21)/ 2 Series (F22/F23)/ 3 Series (F30/F31/F34)/ 4 Series (F32/F36)	28
9.3	Installation location of fuses for Mini (F55/F56/F57)	28

---

## 1 List of abbreviations

CCL	Micro Gateway CAN CAN LIN
K2	Additional relay
K3	Additional relay
SH2	Engine compartment fuse holder for F1/F2
Veh.	Vehicle

---

## 2 Installation notes

### 2.1 Information on Validity

This installation documentation applies to vehicles listed on page 1, assuming technical modifications to the vehicle do not affect installation, any liability claims excluded. Depending on the vehicle version and equipment, modifications may be necessary during installation with respect to this installation documentation. Vehicle and engine types, equipment variants and other specifications not listed in this installation documentation have not been tested. However, installation according to this installation documentation may be possible.

### 2.2 Components used

Designation	Order number
Additional 'Webasto Comfort' A/C control kit for Mini / BMW 2 Series / 3 Series / X1 / X2	1324388J



Please observe the Validity Notes on the next page.

## 2.3 Validity Notes

This installation documentation applies only in combination with:

Designation	Identification number
Installation kit for BMW 2 Series Active Tourer/2 Series Gran Tourer/X1 petrol and diesel/X2 diesel 'Island'	1324379_
Installation documentation for BMW 2 Series/X1	1324380_

or

Installation kit for BMW 2 Series Active Tourer/2 Series Gran Tourer/X1 petrol and diesel/X2 diesel 'Inline'	1325209_
Installation documentation for BMW 2 Series	1325207_

or

Installation kit for BMW X1/X2/2 Series Active Tourer petrol 'Island' 2018	1326525_
Installation documentation for BMW X2 petrol 2018/ BMW X1 petrol 2019	1326526_
or	
Installation documentation for BMW 2 Series Active Tourer petrol 'island' 2018	1327565_

or

Installation kit for BMW 1 Series/3 Series petrol and diesel, 2 Series/4 Series petrol 2015	1324710_
Installation documentation for BMW 1 Series/3 Series petrol and diesel; 2 Series/4 Series petrol 2015	1324709_
or	1325381_
Installation documentation for 3 Series Gran Turismo petrol and diesel 2015	

or

Installation kit for BMW 4 Series diesel 2016	1326040_
Installation documentation for BMW 4 Series diesel 2016	1326135_

or

Installation kit for Mini petrol	1324863_
Installation documentation for Mini petrol	1324864_

or

Installation kit for Mini 5-door diesel	1324865_
Installation documentation for Mini 5-door diesel	1324866_

or

Installation kit for Mini petrol 2021	1329088_
Installation documentation for Mini petrol 2021	1329089_

## 3 About this document

### 3.1 Purpose of the document

This installation documentation is part of the product and contains all the information required to ensure professional vehicle specific installation of the:

'Webasto Comfort' air-conditioning control installation kit

### 3.2 Warranty and liability

Webasto shall assume no liability for defects, damage and injuries resulting from a failure to observe the installation, repair and operating instructions of the information contained in them.

This liability exclusion particularly applies to improper installations and repairs by untrained persons or in the case of a failure to use genuine spare parts.

The liability due to culpable disregard to life, limb or health and due to damage or injuries caused by a wilful or reckless breach of duty remain unaffected, as does the obligatory product liability.

Installation should be carried out according to the general, standard rules of technology. Unless specified otherwise, fasten hoses, lines and wiring harnesses to original vehicle lines and wiring harnesses using cable ties. Insulate loose wire ends and tie back. Connectors on electronic components must audibly snap into place during assembly.

Spray unfinished body areas, e.g. drilled holes, with anti-corrosion wax (Tectyl 100K).

Observe the instructions and guidelines of the respective vehicle manufacturer for demounting and mounting vehicle specific components.

The initial start-up is to be executed with the Webasto Thermo Test Diagnosis.

When installing a programmable control module (e.g. a PWM Gateway), the corresponding settings must be checked or adjusted.

#### 3.2.1 Statutory regulations governing installation

The Thermo Top Evo heater has been type-tested and approved in accordance with ECE-R 10 (EMC) and ECE-R 122 (heater). The regulations of these guidelines are binding in the scope of the Directive 70/156/EEC and/or 2007/46/EC (for new vehicle models from 29/04/2009) and should also be observed in countries in which there are no special regulations.

The heater is licensed in accordance with paragraph 19, section 3, No. 2b of the StVZO (German Road Traffic Licensing Authority).

### 3.3 Safety

#### Qualifications of installation personnel

The installation personnel must have the following qualifications:

- Successful completion of Webasto training
- Corresponding qualification for working on technical systems

#### Regulations and legal requirements

The regulations from the heater's general installation and operating instructions must be observed.

#### 3.3.1 Safety information on installation

##### Danger posed by live parts

- ▶ Prior to installation, disconnect the vehicle from the voltage supply.
- ▶ Make sure the electrical system is earthed correctly.
- ▶ Always comply with legal requirements.
- ▶ Observe data on type label.

##### Danger of fire and leaking toxic gases due to improper installation

- ▶ Vehicle parts in the vicinity of the heater must be protected against excessive heating by the following measures:
  - ⇒ Maintain minimum safety distances.
  - ⇒ Ensure adequate ventilation.
  - ⇒ Use fire-resistant materials or heat shields.

##### Danger due to sharp edges









- Lacerations
- Short circuit due to electrical wire damage
- ▶ Fit protectors on sharp edges.

### 3.4 Using this document

Before installing and operating the heater, read this installation documentation, the installation instructions of the heater, the operating instructions and supplementary sheets provided.

#### 3.4.1 Explanatory Notes on the Document

There is an identification mark near the respective work step to allow you to quickly allocate the other applicable documents to the Webasto components to be installed:

Generally valid Webasto documentation	
Vehicle-specific installation documentation	
Vehicle-specific installation documentation of the cold start kit	
Webasto Comfort A/C control	
Webasto Standard A/C control	
Tank extracting device (e.g. FuelFix)	
Exhaust end fastener (EFIX)	
Combustion air intake silencer	
Spacer bracket (ASH)	

#### 3.4.2 Use of symbols



#### DANGER

Type and source of the risk

Consequences: Failure to follow the instructions can result in death.

► Actions to protect yourself against risks.



#### WARNING

Type and source of the risk

Consequences: Failure to follow the instructions can lead to serious or even fatal injuries.

► Actions to protect yourself against risks.



#### CAUTION

Type and source of the risk

Consequences: Failure to follow the instructions can lead to minor injuries.

► Actions to protect yourself against risks.



Type and source of the risk

Consequences: Failure to follow the instructions can lead to material damage.

► Actions to protect yourself against risks.











Reference to the vehicle manufacturer's specific documents.

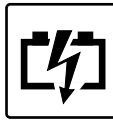

Note on a special technical feature

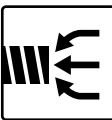
#### 3.4.3 Work step identification marks

The ongoing work step is indicated on the outside top corner of the page:

Mechanical system	Electrical system	High-voltage	Coolant
			
Combustion air	Fuel	Exhaust	Software
			

#### 3.4.4 Orientation aid

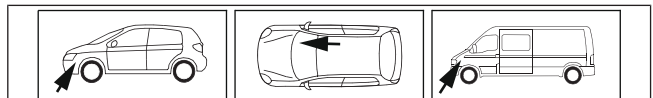

The arrow indicates the position on the vehicle and the viewing angle.

#### 3.4.5 Use of highlighting

Highlight	Explanation
✓	Action
►	Necessary action
⇒	Result of an action
<b>1</b> / <b>12</b> / <b>a1</b>	Position numbers for the image descriptions
<b>①</b> / <b>⑫</b> / <b>Ⓐ</b>	Position numbers for the image descriptions for electrical wires and components as well as coolant hose sections

---

## 4 Technical Information

### Dimension specifications

- All dimensions specified in mm
- Perforated brackets and mounting angles are shown to scale
- Observe data regarding scale on the templates

### Tightening torque specifications

- Tighten all screw connections in accordance with manufacturer's instructions or in accordance with state-of-the-art-technology

### Necessary special tools

- Automatic wire stripper 0.2 - 6 mm<sup>2</sup>
- Crimping pliers for connector 0.25 – 6 mm<sup>2</sup>
- Torque wrench for 2.0 - 10 Nm
- Deep-hole marker



## 5 Preparations

### 5.1 Vehicle preparation



Further information can be found in the vehicle manufacturer's technical documentation.

Vehicle area	Components to be removed	Other applicable documents
Engine compartment and body	<ul style="list-style-type: none"> <li>▶ Disconnect the battery (in case of BMW 1 Series/2 Series (F22/F23) / 3 Series and 4 Series / X1 and X2 in the boot)</li> </ul>	

#### BMW 2 Series (F45/F46) / X1 (F48) / X2 (F39)

Passenger compartment	<ul style="list-style-type: none"> <li>▶ Side instrument panel trim on the driver's and front passenger's side</li> <li>▶ Lower instrument panel trim on the driver's side</li> <li>▶ Air duct footwell on the driver's side</li> <li>▶ Footwell trim on the front passenger's side</li> <li>▶ Front centre console trim on the driver's and front passenger's side</li> </ul>	
-----------------------	--	--

#### BMW 1 Series (F20/F21) / 2 Series (F22/F23) / 3 Series (F30/F31/F34) / 4 Series (F32/F36)

Passenger compartment	<ul style="list-style-type: none"> <li>▶ Side instrument panel trim on the front passenger's side</li> <li>▶ Footwell trim on the front passenger's side</li> <li>▶ Glove box</li> <li>▶ Air-conditioning control unit</li> </ul>	
-----------------------	---	--

#### Mini (F55/F56/F57)

Passenger compartment	<ul style="list-style-type: none"> <li>▶ Side instrument panel trim on the driver's side</li> <li>▶ Lower instrument panel trim on the driver's side</li> <li>▶ Footwell trim on the front passenger's side</li> <li>▶ Side trim of the centre console on the driver's and front passenger's side</li> </ul>	
-----------------------	--	--

## 6 Installation overviews

BMW 2 Series (F45/F46) / X1 (F48) / X2 (F39)

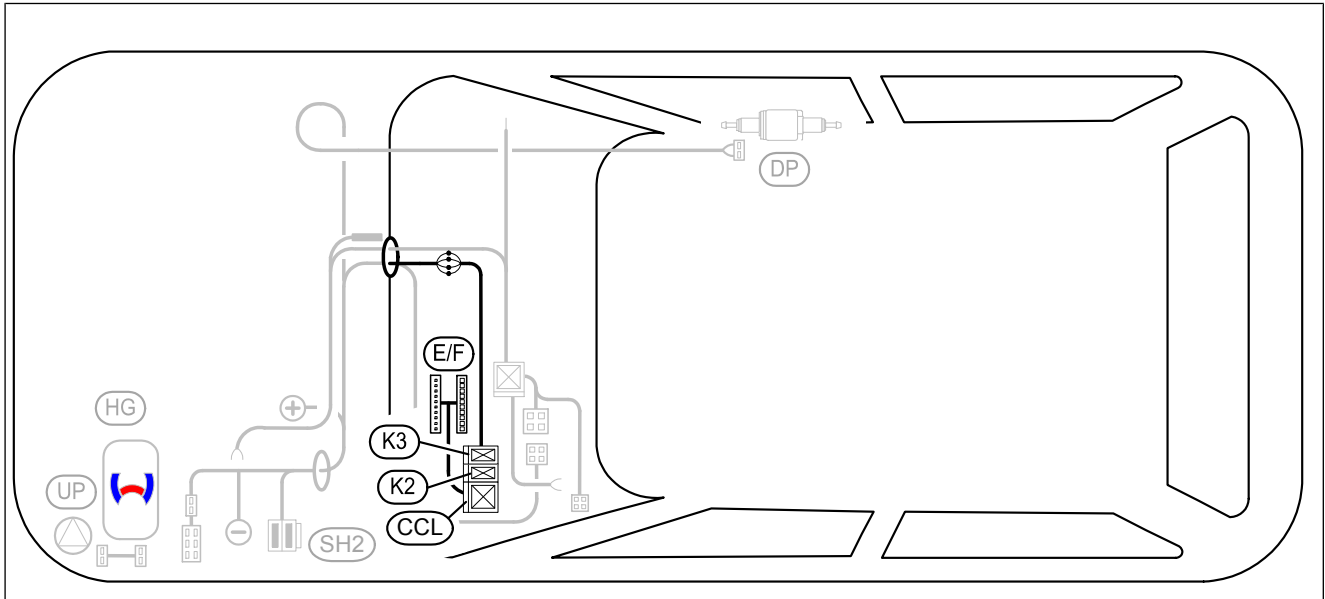

Fig. 1

BMW 1 Series (F20/F21) / 2 Series (F22/F23) / 3 Series (F30/F31/F34) / 4 Series (F32/F36)

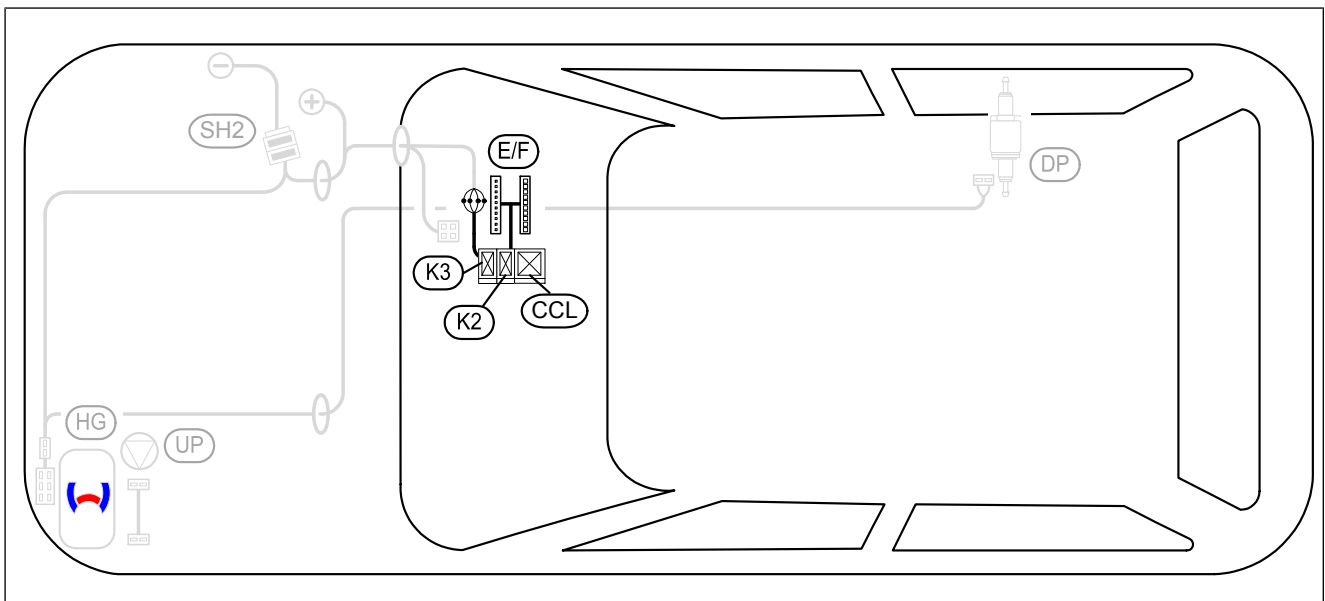

Fig. 2

## Mini (F55/F56/F57)

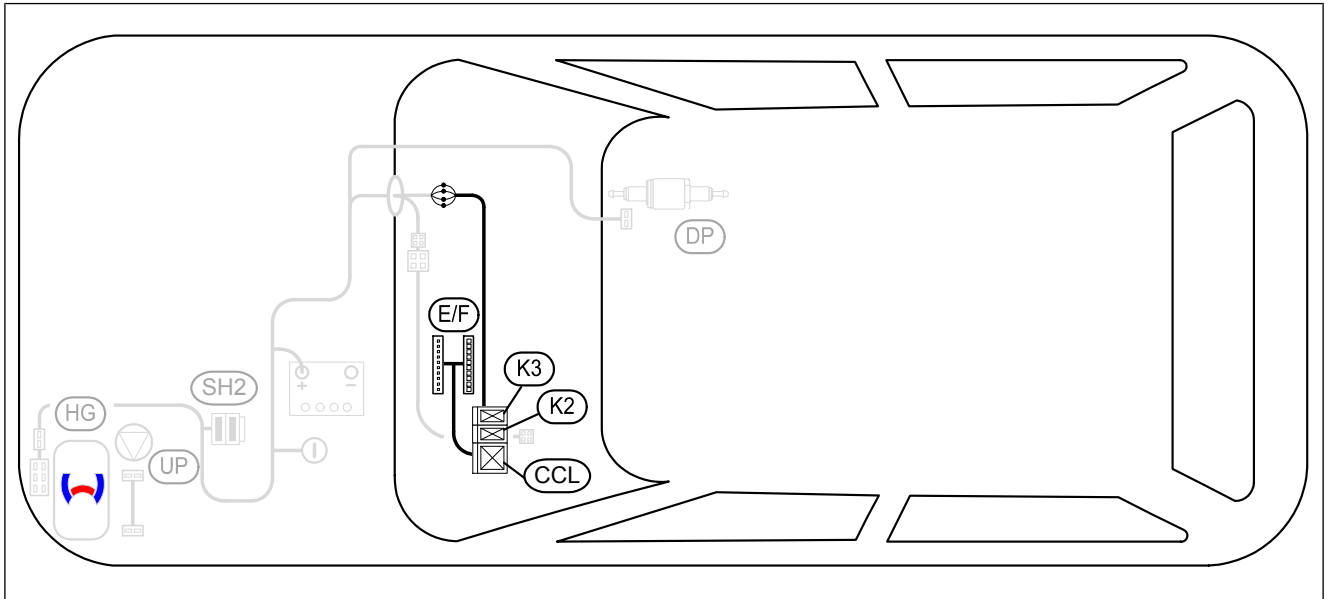

Fig. 3

### Legend to installation overview

Abbr.	Component
CCL	CCL Gateway
E/F	Wiring harness adapter connector Plug&Play
K2	Additional relay K2
K3	Additional relay K3



## 7 Electrical system

### 7.1 Electrical system preparation

#### Preparing SH2

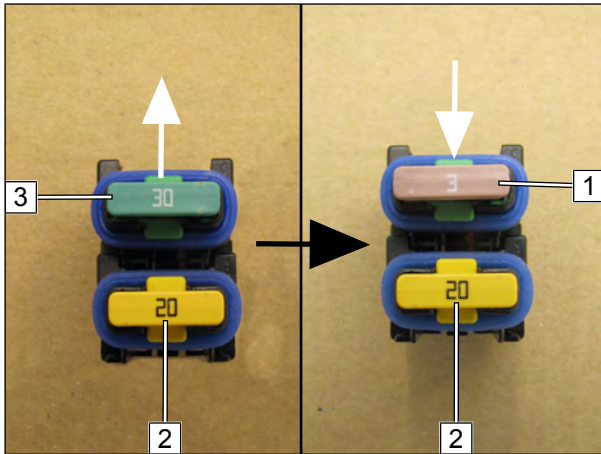

Fig. 4

► Replace 30A passenger compartment main fuse F2 **3** with 3A fuse **1**.

**2** Fuse F1: 20A

### 7.2 Glove box dismantling instructions (1 Series / 2 Series (F22/F23)/3 Series /4 Series only)

#### Removing trim piece

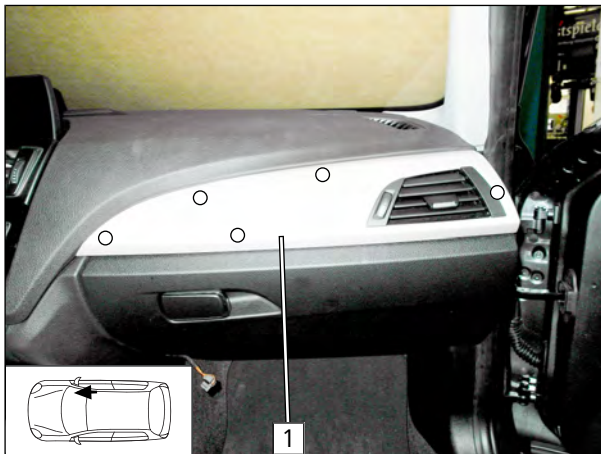

Fig. 5



Trim piece not present in all vehicle models.

► Detach trim piece **1** from clips by pulling it forwards.

○ Retaining clip

#### Removing bolts

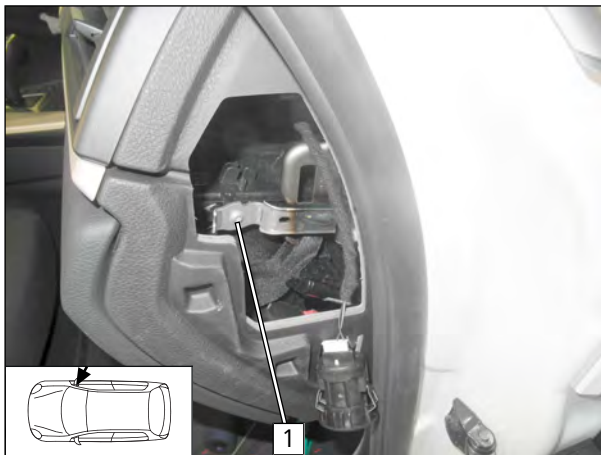

Fig. 6



This and the next figures show a vehicle of the 3 Series but apply to all models.

**1** Original vehicle bolt, if present

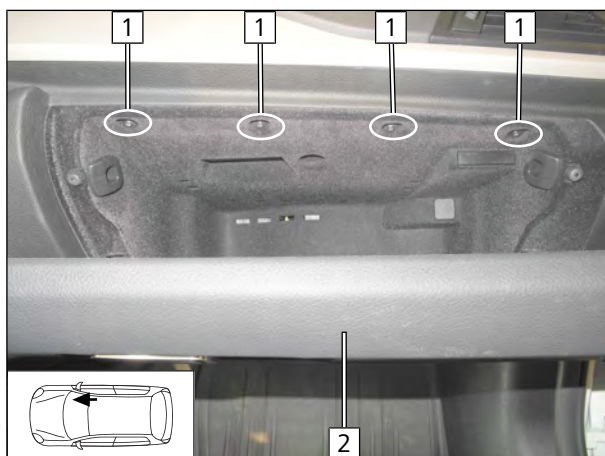

Fig. 7

► Open glove box **2**.

**1** Original vehicle bolt



Fig. 8

**1** Original vehicle bolt



Fig. 9

► Remove the glove box.

**1** Original vehicle bolt



### 7.3 Wiring diagram

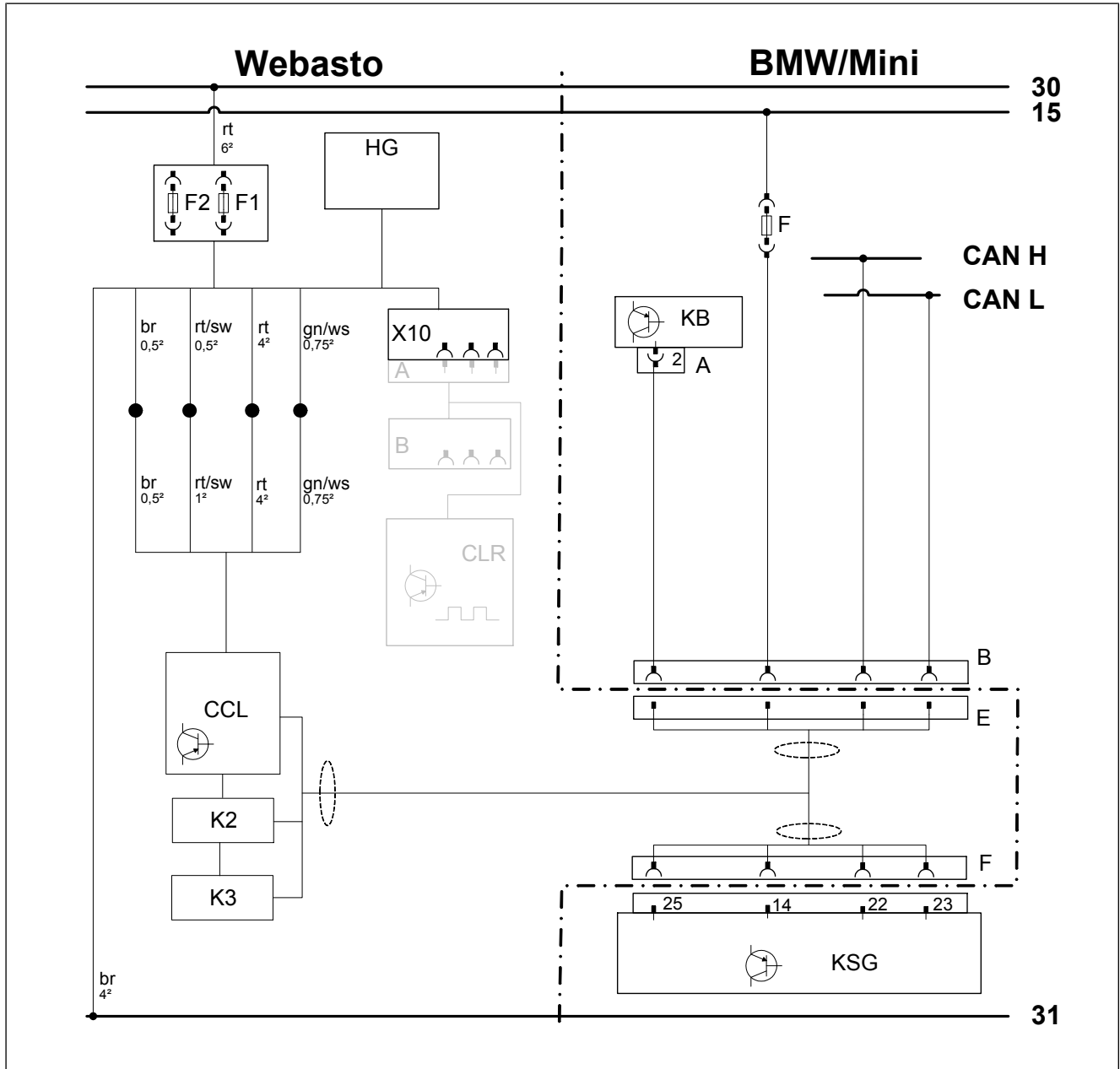

Fig. 10



## Legend to wiring diagram



The vehicle connector and component designations are freely chosen by Webasto.  
Wiring colours may vary.

Vehicle components		Note	
Abbreviation	Component	Graphic	Designation
F	KSG fuse		
KB	A/C control panel		
A	KB connector		
KSG	Air-conditioning control unit		
B	26-pin KSG connector		

Webasto components		Symbols	
Abbreviation	Component	Graphic	Designation
A	Male plug for CLR module wiring harness	X	Cutting point
B	Female plug for CLR module wiring harness	●	existing electrical connection
C	Male plug for adapter wiring harness	●	new electrical connection
D	Female plug for adapter wiring harness		Wiring harness section or protective sleeving
E	Male plug for Plug&Play wiring harness		Insulate and tie back wire
F	Female plug for Plug&Play wiring harness		The connection is carried out as described in the heater installation documentation
CCL GW	Micro Gateway CAN CAN LIN		
CL GW	Micro SPS CAN / WBus (Gateway CAN LIN)		
CLR	CAN LIN Rxx (cold start module)		
D1	Diode		
D2	Diode group		
F0	Additional fuse for power supply		
F1	Heater main fuse		
F2	Passenger compartment fan controller main fuse		
F3	Control element fuse		
F4	Fan controller fuse		
F5	Additional fuse		
HG	Heater TT-Evo		
K1	Relay K1		
K2	Relay K2		
K3	Relay K3		
LA	Power adapter		
LIN GW	LIN Gateway		
MV	Solenoid valve		
PWM GW	LIN Gateway / PWM (pulse width modulator)		
RSH	Relay and fuse holder of passenger compartment		
RTD	Temperature sensor		
X10	Female plug for control element		

Wire colours	
Abbreviation	Colour
bg	beige
bl	blue
br	brown
dbl	dark blue
dgn	dark green
ge	yellow
gn	green
gr	grey
hbl	light blue
hgn	light green
la	salmon
or	orange
pk	pink
ro	Pink
rt	red
sw	black
vi	violet
ws	white



## 7.4 Fan controller of BMW 2 Series (F45/F46) / X1(F48) / X2(F39)

### Premounting CCL, relay K2 and relay K3 sockets

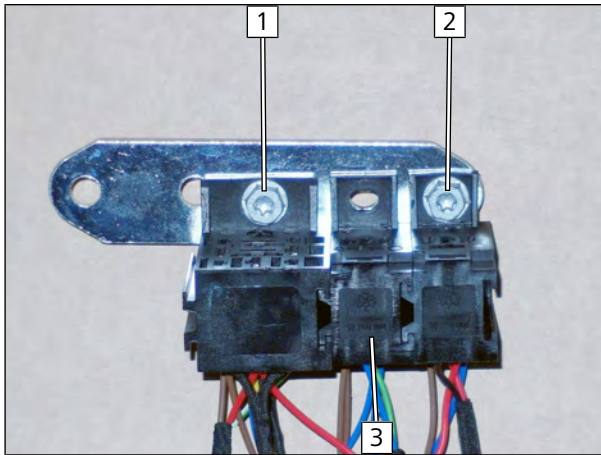

Fig. 11



Produce all following electrical connections as shown in the system wiring diagram.

- 1 M5x13 bolt, CCL socket, perforated bracket, flanged nut
- 2 M5x13 bolt, relay K3 socket, perforated bracket, flanged nut
- 3 Relay K2 socket

### Mounting CCL, relay K2 and relay K3

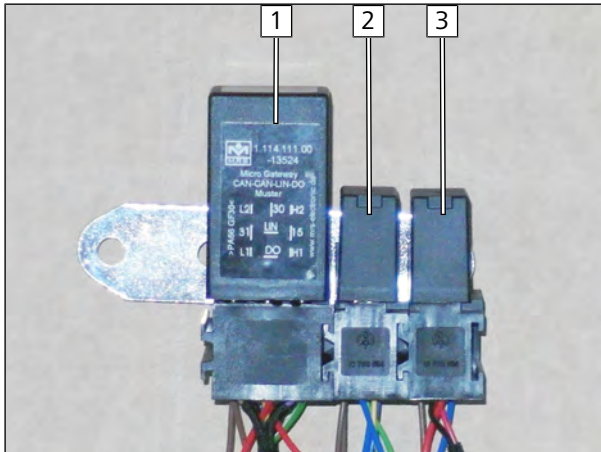

Fig. 12

- 1 CCL
- 2 Relay K2
- 3 Relay K3

### Mounting eyelet cable tie

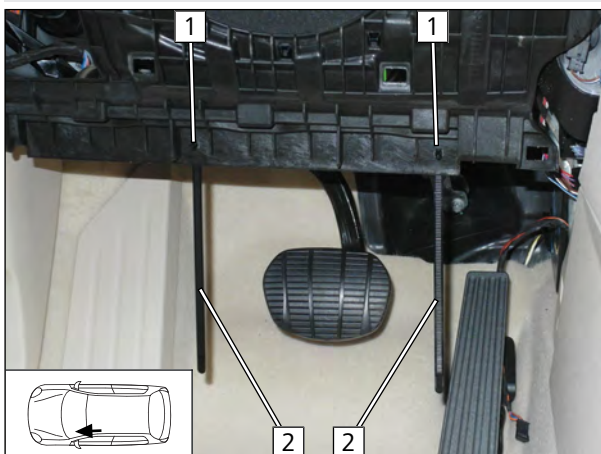

Fig. 13

► Drill a  $\varnothing 6.0$  hole at position 1.

- 2 Eyelet cable tie





## Mounting CCL, relay K2 and relay K3 sockets

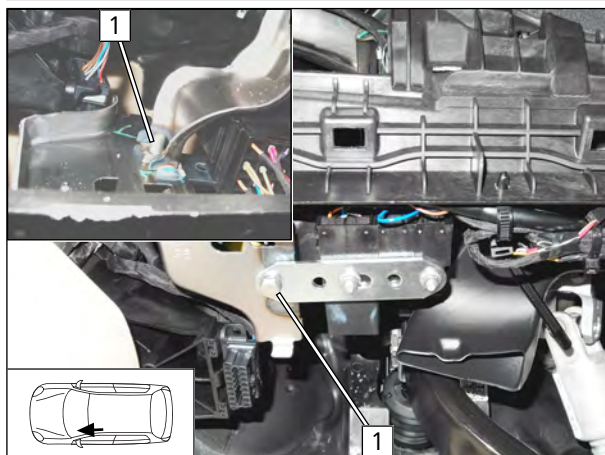

Fig. 14

- 1 M6x20 bolt, spring lock washer, premounted perforated bracket, original vehicle threaded hole

## Routing wiring harness

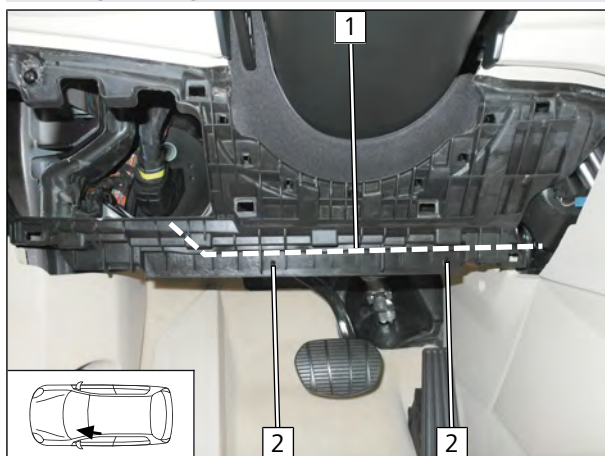

Fig. 15

- Route Plug&Play wiring harness 1 to the centre console and fasten with premounted eyelet cable tie 2.

## Disconnecting 26-pin connector B

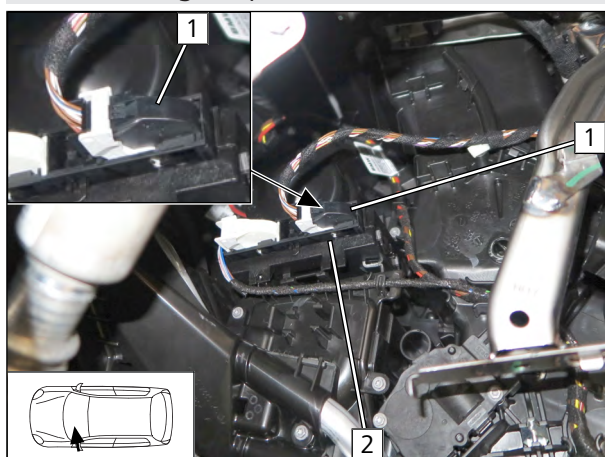

Fig. 16

- Disconnect 26-pin connector B 1 from A/C control unit.
- 2 Air-conditioning control unit



## Mounting Plug&Play wiring harness

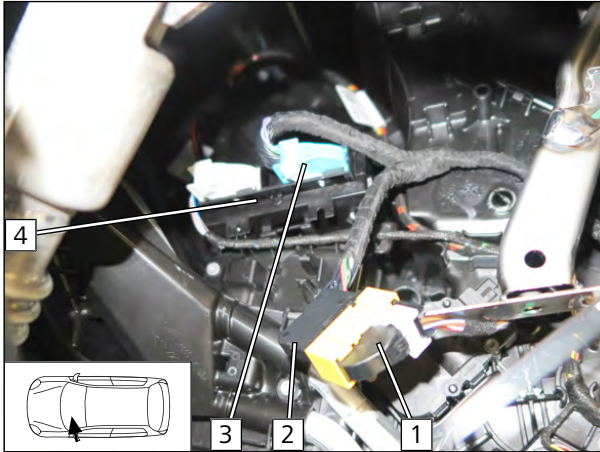

Fig. 17

- ▶ Connect 26-pin A/C control unit connector B **1** with 26-pin male plug E **2** of Plug&Play wiring harness.
- ▶ Connect 26-pin female plug F **3** of Plug&Play wiring harness to control unit **4**.
- ▶ Route wire ends of Plug&Play wiring harness to the front passenger's side.

## 7.5 Fan controller of BMW 1 Series (F20/F21)/ 2 Series (F22/F23)/ 3 Series (F30/F31/F34)/ 4 Series (F32/F36)

### Cutting perforated bracket to length

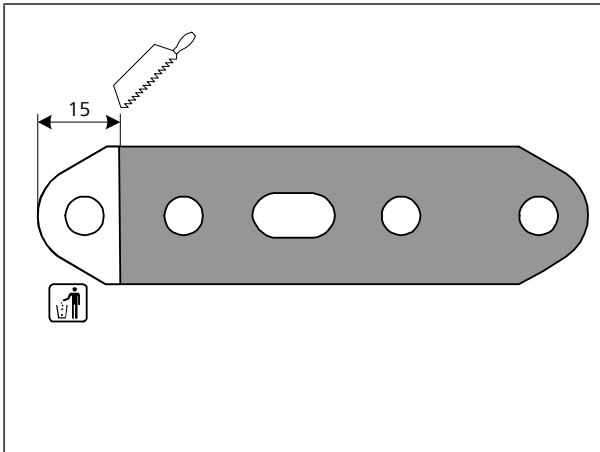

Fig. 18

### Premounting CCL, relay K2 and relay K3 sockets

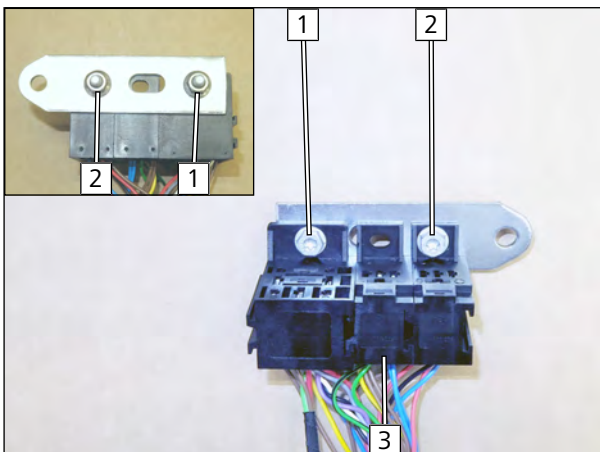

Fig. 19



Produce all following electrical connections as shown in the system wiring diagram.

- 1** M5x13 bolt, CCL socket, perforated bracket, flanged nut
- 2** M5x13 bolt, relay K3 socket, perforated bracket, flanged nut
- 3** Relay K2 socket



## Mounting CCL, relay K2 and relay K3

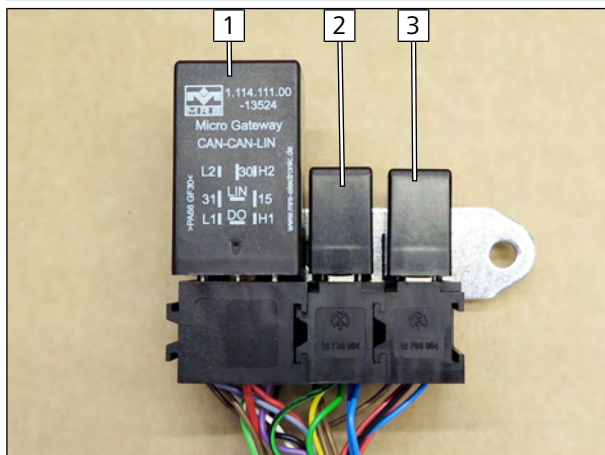

Fig. 20

- 1 CCL
- 2 Relay K2
- 3 Relay K3

## Premounting bolts

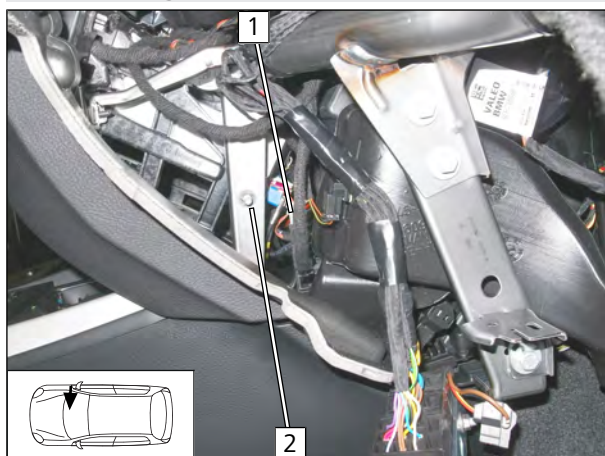

Fig. 21

- ▶ Detach plastic clip 1 on original vehicle line at pos. 2.
- 2 M6x12 bolt (inserted from behind), original vehicle hole, lock washer

## Mounting CCL, relay K2 and relay K3 sockets



Fig. 22

- 1 Pre-mounted M6x12 bolt, original vehicle hole, pre-mounted perforated bracket, flanged nut



## Dismantling A/C control unit

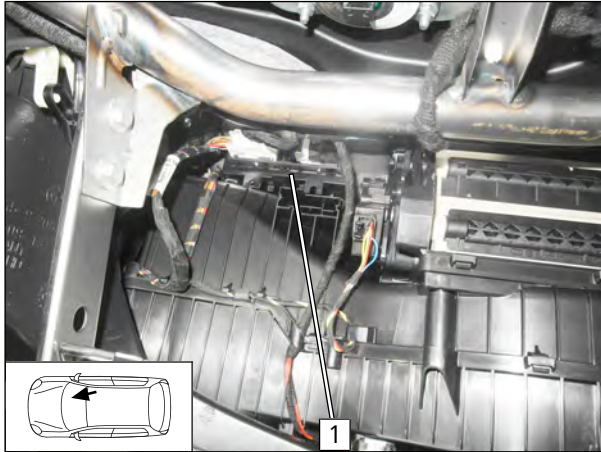

Fig. 23

- ▶ Remove A/C control unit **1** from bracket.

## Disconnecting 26-pin connector B from A/C control unit

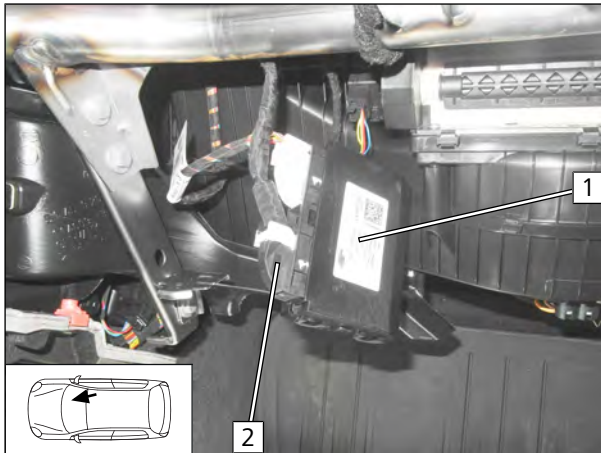

Fig. 24

- 1** Air-conditioning control unit
- 2** 26-pin connector B

## Mounting Plug&Play wiring harness

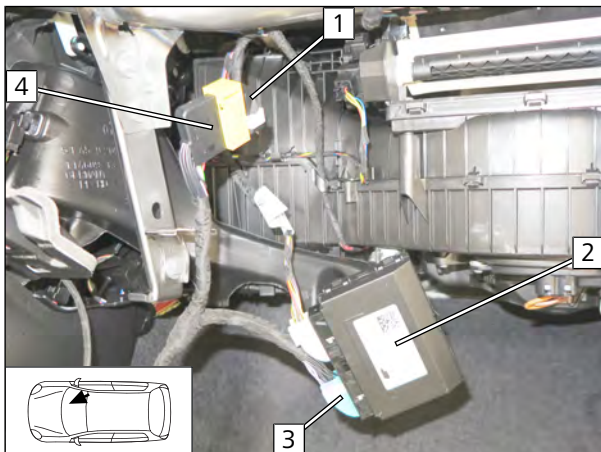

Fig. 25

- ▶ Connect 26-pin A/C control unit connector B **1** with 26-pin male plug E **4** of Plug&Play wiring harness.
- ▶ Connect 26-pin female plug F **3** of Plug&Play wiring harness to control unit **2**.
- ▶ Mount control unit **2** again and fasten wiring harnesses.



## 7.6 Fan controller of Mini (F55/F56/F57)

### Premounting CCL, relay K2 and relay K3 sockets

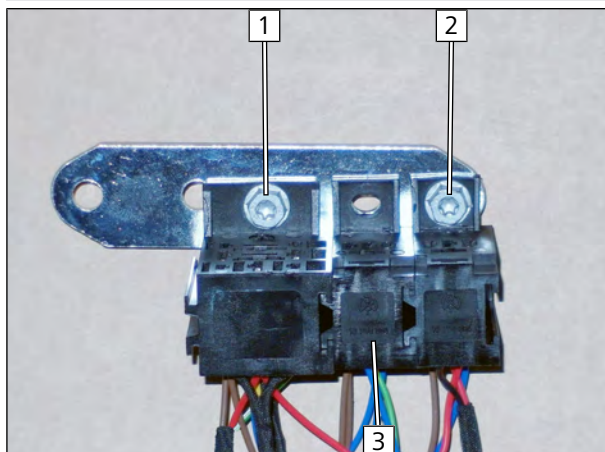

Fig. 26



Produce all following electrical connections as shown in the system wiring diagram.

- 1 M5x13 bolt, CCL socket, perforated bracket, flanged nut
- 2 M5x13 bolt, relay K3 socket, perforated bracket, flanged nut
- 3 Relay K2 socket

### Mounting CCL, relay K2 and relay K3

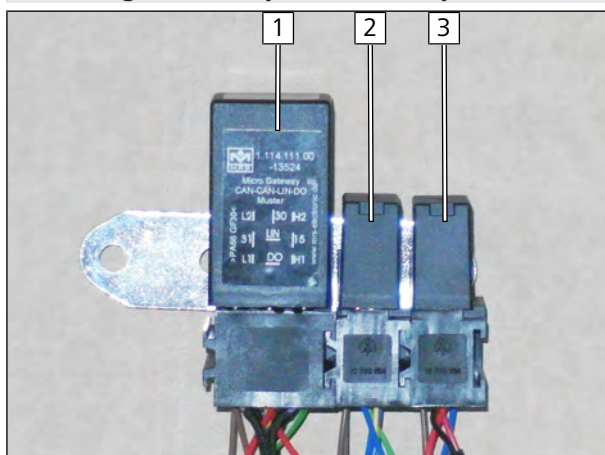

Fig. 27

- 1 CCL
- 2 Relay K2
- 3 Relay K3

### Mounting eyelet cable tie

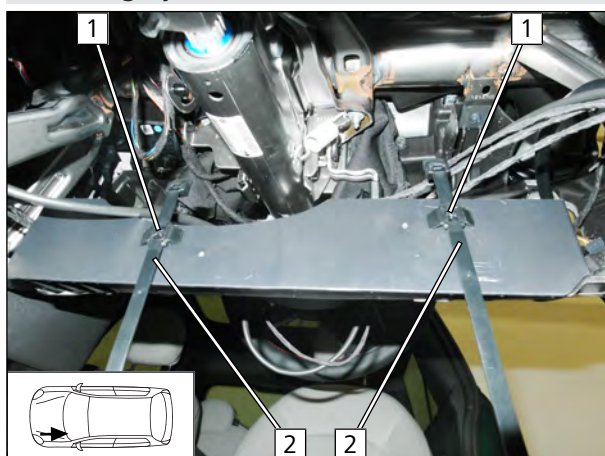

Fig. 28



see also next figure

- Drill a  $\varnothing 6.0$  hole at position **1**.
- 2** Eyelet cable tie

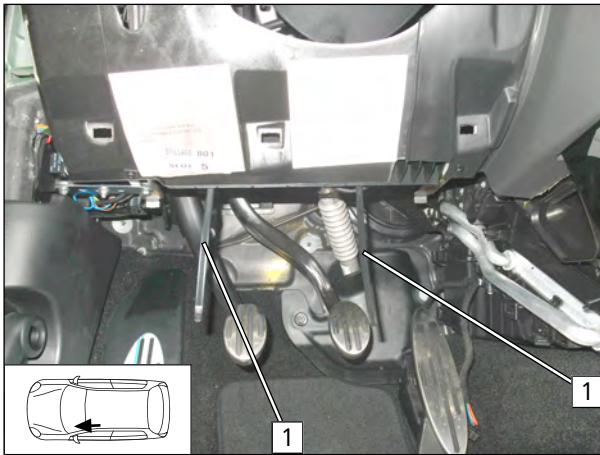

Fig. 29

1 Eyelet cable tie

### Mounting CCL, relay K2 and relay K3 sockets

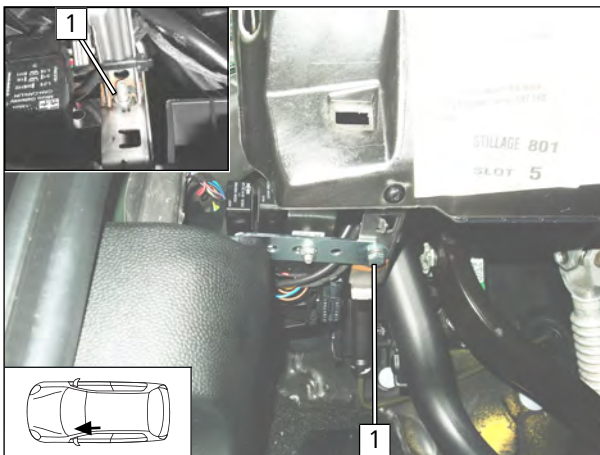

Fig. 30

1 M6x20 bolt, spring lock washer, premounted perforated bracket, original vehicle threaded hole

### Routing wiring harness

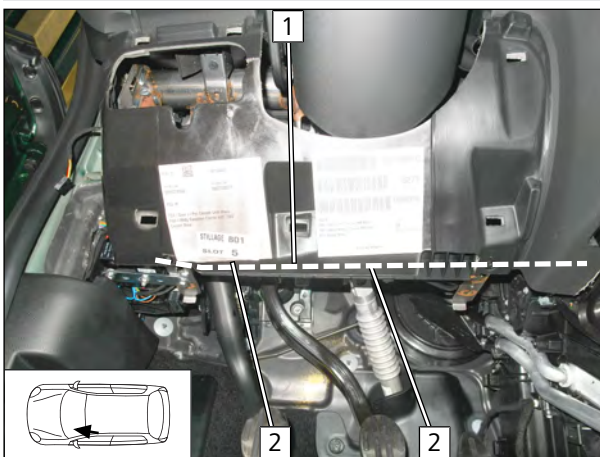



Fig. 31

 see also next figure

► Route Plug&Play wiring harness 1 to the centre console and fasten with premounted eyelet cable tie 2.

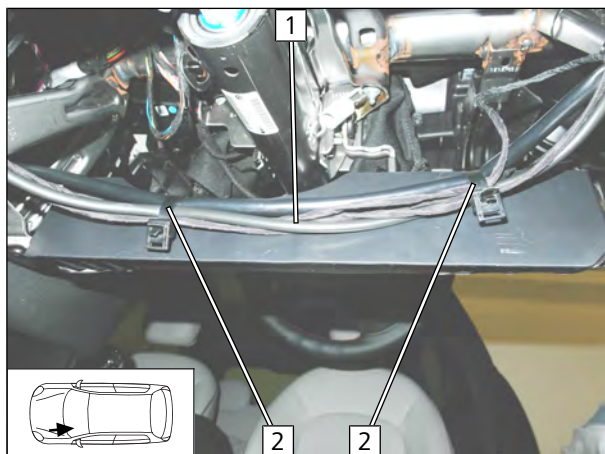

Fig. 32

- 1 Plug&Play wiring harness
- 2 Premounted eyelet cable tie

### Disconnecting 26-pin connector B

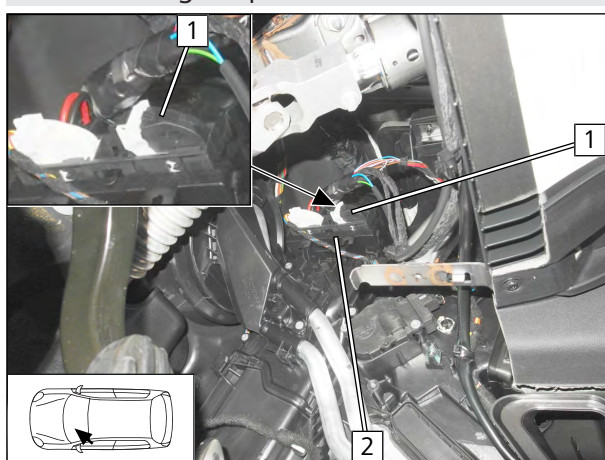

Fig. 33

- ▶ Disconnect 26-pin connector B **1** from A/C control unit **2**.

### Mounting Plug&Play wiring harness

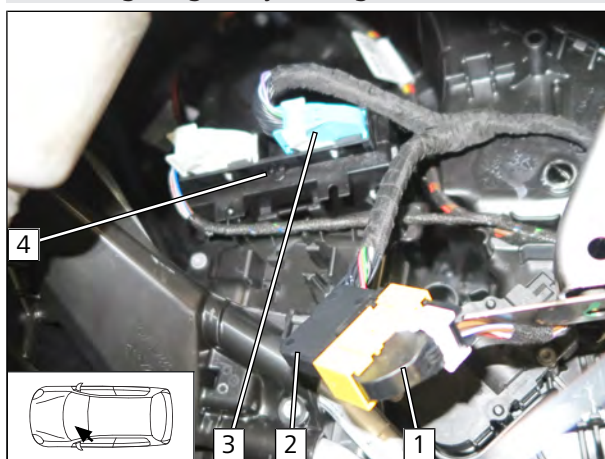

Fig. 34

- ▶ Connect 26-pin A/C control unit connector B **1** with 26-pin male plug E **2** of Plug&Play wiring harness.
- ▶ Connect 26-pin female plug F **3** of Plug&Play wiring harness to control unit **4**.



## Routing 4-pin connecting wire of Plug&Play wiring harness to the front passenger's side

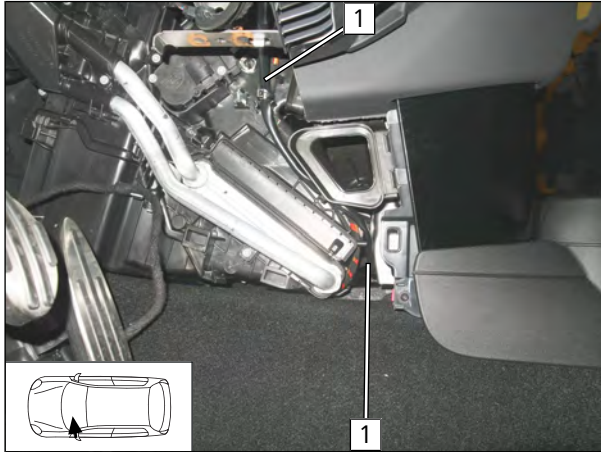

Fig. 35

1 4-pin connecting wire of Plug&Play wiring harness

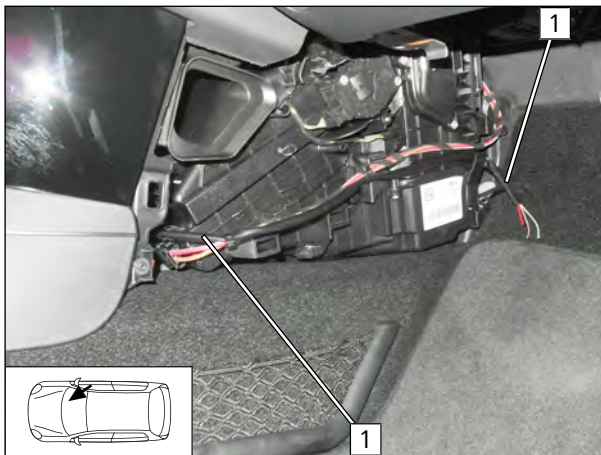

Fig. 36

1 4-pin connecting wire of Plug&Play wiring harness

## 7.7 Connecting same colour wires of wiring harnesses, all vehicles

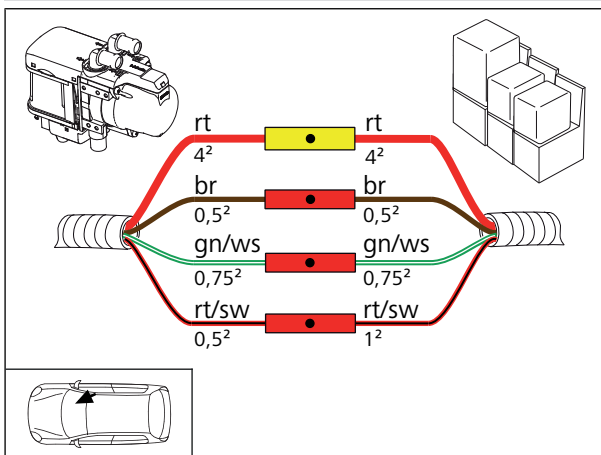

Fig. 37





## 8 Final work



- ▶ Final work is not carried out until the installation of the heater in the vehicle has been completed
- ▶ Check all electrical connections for firm seating
- ▶ Insulate and tie back loose lines



### **Fill in the note field for the parking heater function**

- ▶ Fill in the note field for the parking heater function on the 'Operating instructions' page according to the type of heater installation in the vehicle.



This is a translation from the original German installation instructions.  
To request this Installation Documentation in another language, please locate and contact your local Webasto dealer.  
You can find your nearest dealer at: <https://dealerlocator.webasto.com/en-int>.

© Copyright 2022 - The contents of this document, including but not limited to text, photographs and graphics, are protected by copyright. All rights, including reproduction, publication, editing and translation in any way, shape or form, are reserved by Webasto.

Webasto Thermo & Comfort SE  
Postfach 1410  
82199 Gilching  
Germany

Company address:  
Friedrichshafener Str. 9  
82205 Gilching  
Germany

Technical Extranet: <https://dealers.webasto.com>



[WWW.WEBASTO.COM](http://WWW.WEBASTO.COM)

## 9 Operating instructions



### Vehicles with passenger compartment monitoring

Further information can be found in the vehicle operating instructions.

- ▶ Deactivate passenger compartment monitoring for the heating operation.



### Notes about the A/C control panel presettings

Your vehicle is equipped with a comfort air-conditioning control. As a result, **no** settings are required on the A/C control panel when switching off the vehicle. All necessary presettings, such as fan speed, temperature and flap positions are set automatically.



### Notes about the active parking heating mode

The vehicle fan is deactivated when the vehicle is opened and is available again once the ignition is switched on.

After the vehicle is closed again, it can take several minutes for it to be active again.



### Note for current consumption in case of parking heating mode

Depending on the vehicle model, there may be an increased quiescent current consumption message in the vehicle information system during or directly after operation in parking heating mode.

- ▶ This is not an error that can affect the vehicle on a technical level.



### Note for parking heater function

Your vehicle is equipped with a passenger compartment and engine preheating unit.



### Note for parking heater function

Your vehicle is equipped with a passenger compartment preheating unit. There is **no** engine pre-heating.

## 9.1 Installation location of fuses for BMW 2 Series (F45/F46) / X1(F48) / X2 (F39)

### Fuses in engine compartment

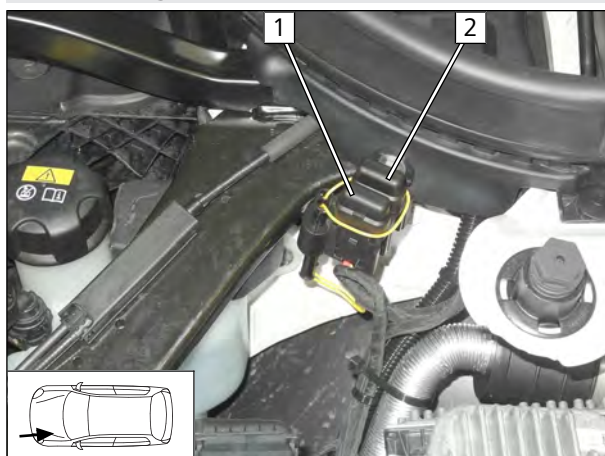

Fig. 38

- 1 F1 - 20A heater main fuse
- 2 F2 - 3A main fuse of passenger compartment

## 9.2 Installation location of fuses for BMW 1 Series (F20/F21)/ 2 Series (F22/F23)/ 3 Series (F30/F31/F34)/ 4 Series (F32/F36)

### Fuses in engine compartment

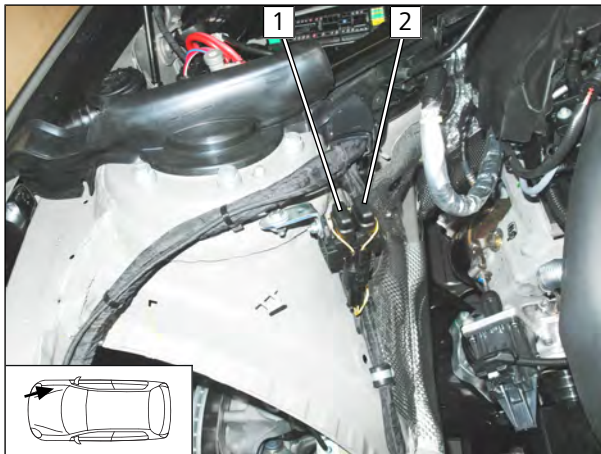

Fig. 39

- 1 F1 - 3A main fuse of passenger compartment
- 2 F2 - 20A heater main fuse

## 9.3 Installation location of fuses for Mini (F55/F56/F57)

### Fuses in engine compartment

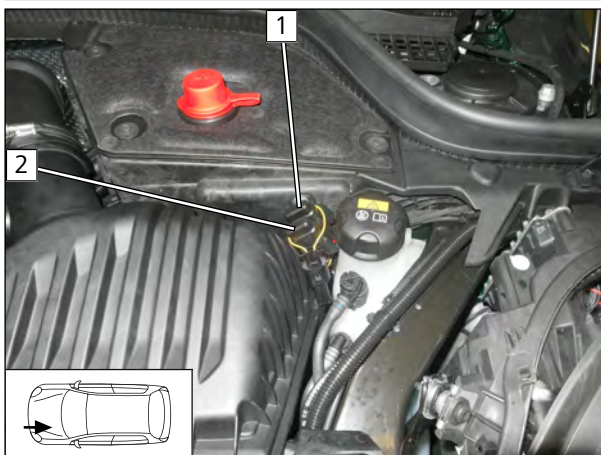

Fig. 40

- 1 F1 - 3A main fuse of passenger compartment
- 2 F2 - 20A heater main fuse