

**7900-M006-2**

**GIDW - GIDF - GIDCOL  
G1000A46 - G1000A47**

INSTRUCTION MANUAL

**GB**

TRANSLATION FROM THE  
ORIGINAL INSTRUCTIONS

---

*For spare parts drawings refer to the section "LIST OF COMPONENTS" enclosed to this manual.*

---

- For any further information please contact your local dealer.

**SUMMARY**

<b>1.0 GENERAL INFORMATION</b> _____	<b>5</b>	<b>10.5 Inflation procedure</b> _____	<b>11</b>
<b>2.0 INTENDED USE</b> _____	<b>5</b>	<b>10.5.1 Inflation of wheels for truck</b> _____	<b>11</b>
<b>2.1 Personnel training</b> _____	<b>5</b>	<b>10.6 Setting of beading-in overpressure and of the number of tyre washing cycles with nitrogen</b> _____	<b>11</b>
<b>3.0 SAFETY DEVICES</b> _____	<b>5</b>	<b>10.6.1 How to modify the prearranged values</b> _____	<b>11</b>
<b>4.0 GENERAL SAFETY RULES</b> _____	<b>6</b>	<b>10.6.2 Functioning of the inflating device</b> _____	<b>12</b>
<b>5.0 PACKAGING AND HANDLING FOR TRANSPORT</b> _____	<b>6</b>	<b>10.7 Procedure for controlled beading-in of run-flat tyres (function activated only in the program "Car")</b> _____	<b>12</b>
<b>6.0 UNPACKING</b> _____	<b>6</b>	<b>10.8 Checking of the actual pressure measured (for the annual inspection and the checking of device calibration)</b> _____	<b>12</b>
<b>7.0 ASSEMBLY AND COMMISSIONING</b> _____	<b>6</b>	<b>11.0 ROUTINE MAINTENANCE</b> _____	<b>13</b>
<b>7.1 Accessories inside the packaging</b> _____	<b>6</b>	<b>11.1 GIDW version</b> _____	<b>13</b>
<b>7.2 Assembly procedure GIDW</b> _____	<b>7</b>	<b>11.2 GIDF + GIDCOL version on column</b> _____	<b>13</b>
<b>7.3 Assembly procedure GIDF + GIDCOL (fixing on column)</b> _____	<b>7</b>	<b>11.3 G1000A46 - G1000A47 version on tyre demounting device</b> _____	<b>13</b>
<b>7.4 Assembly procedure G1000A46 - G1000A47 (fixing on tyre demounting device)</b> _____	<b>8</b>	<b>12.0 TROUBLESHOOTING TABLE</b> _____	<b>14</b>
<b>7.5 Connecting procedure of automatic digital Inflator to tyre demounting device</b> _____	<b>8</b>	<b>13.0 TECHNICAL DATA</b> _____	<b>15</b>
<b>8.0 LIGHTING</b> _____	<b>9</b>	<b>13.1 Dimensions</b> _____	<b>15</b>
<b>9.0 CONTROLS</b> _____	<b>9</b>	<b>14.0 STORING</b> _____	<b>15</b>
<b>10.0 USING THE DEVICE</b> _____	<b>10</b>	<b>15.0 SCRAPPING</b> _____	<b>15</b>
<b>10.1 Environmental conditions of use</b> _____	<b>10</b>	<b>16.0 NAMEPLATE DATA</b> _____	<b>15</b>
<b>10.2 Inflating a tyre</b> _____	<b>10</b>	<b>17.0 LIST OF COMPONENTS</b>	
<b>10.3 Selection of the inflation program</b> _____	<b>10</b>		
<b>10.4 Handling of the tyre</b> _____	<b>10</b>		

FIG. 1 - GIDW

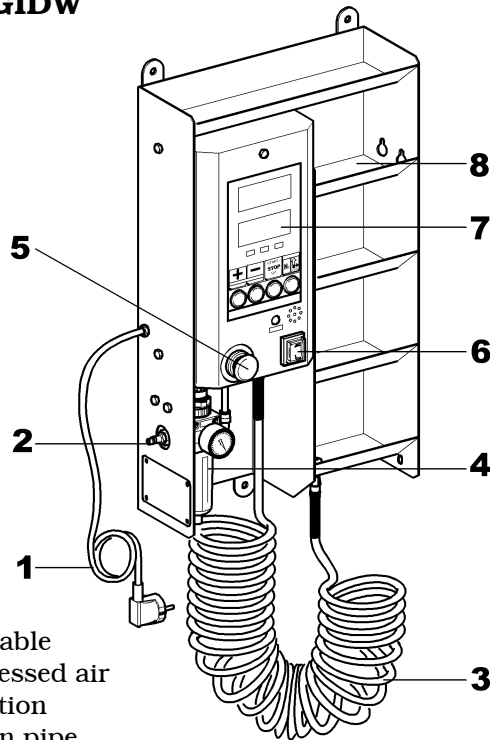

## KEY

- 1 - Input cable
- 2 - Compressed air connection
- 3 - Inflation pipe
- 4 - Filtration unit
- 5 - Emergency push button
- 6 - Ignition switch
- 7 - Control console
- 8 - Equipment compartment

FIG. 2 - G1000A46 - G1000A47- ASSEMBLY ON TYRE DEMOUNTING DEVICE

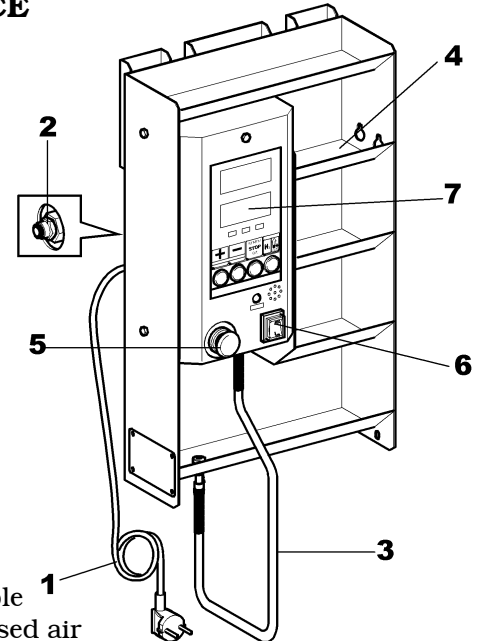

## KEY

- 1 - Input cable
- 2 - Compressed air connection
- 3 - Inflation pipe
- 4 - Equipment compartment
- 5 - Emergency push button
- 6 - Ignition switch
- 7 - Control console

FIG. 3 - GIDF + GIDCOL - ASSEMBLY ON COLUMN

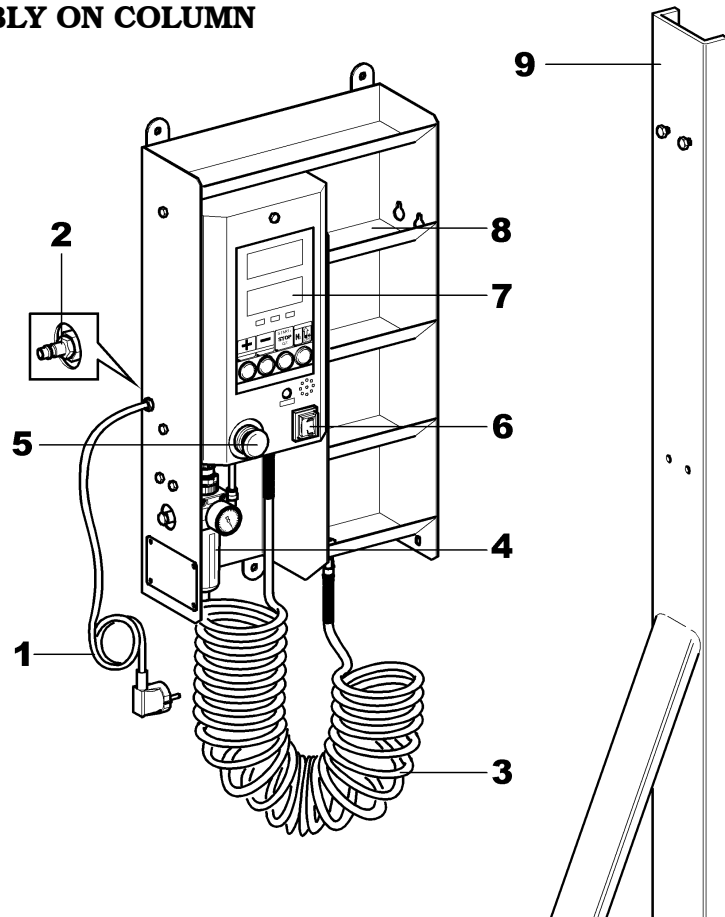

## KEY

- 1 - Input cable
- 2 - Compressed air connection
- 3 - Inflation pipe
- 4 - Filtration unit
- 5 - Emergency push button
- 6 - Ignition switch
- 7 - Control console
- 8 - Equipment compartment
- 9 - Column (GIDCOL)

**INFORMATION PLATE LOCATION TABLE**

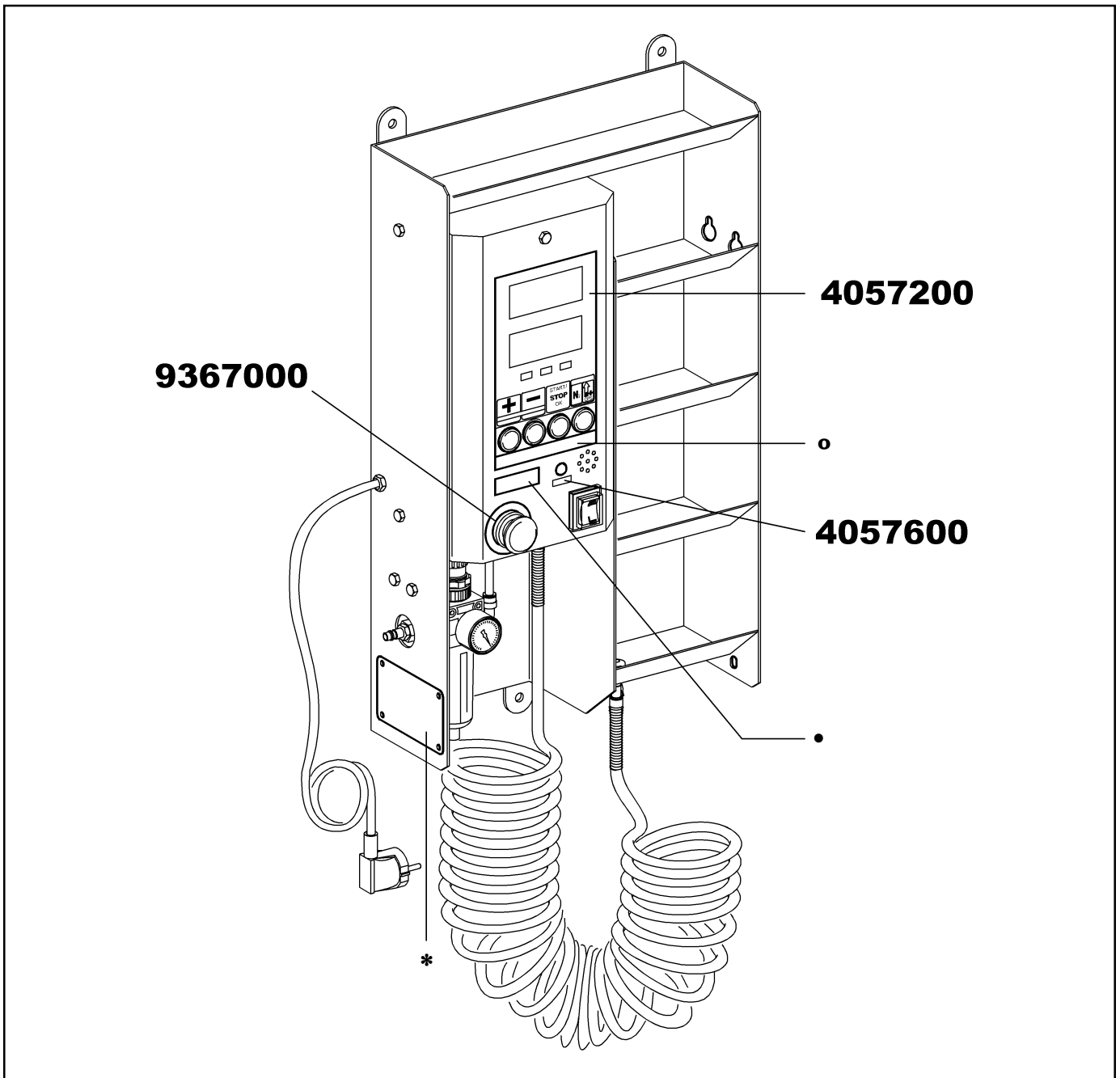

**Code numbers of plates placed on the machine**

<b>4057200</b>	<i>Control plate</i>
°	<i>"Automatic digital Inflator" data plate</i>
<b>4057600</b>	<i>"Truck" program selection indicating plate</i>
*	<i>Data plate</i>
•	<i>Little trade-mark plate</i>
<b>9367000</b>	<i>Emergency pushbutton plate</i>



**IF ONE OR MORE DECALS ON THE MACHINE ARE LOST OR BECOME ILLEGIBLE, THEY MUST BE REPLACED, STATING THE RELATIVE CODE NUMBER WHEN ORDERING THE REPLACEMENT.**

**N.B.:** Some illustrations in this manual have been obtained from photographs of prototypes; standard production machines may therefore differ in some components.

## 1.0 GENERAL INFORMATION

**This manual constitutes an integral part of the product.**

Read the warnings and instructions in this manual carefully, since they provide important information concerning **SAFETY IN USE AND MAINTENANCE**.



**KEEP THIS MANUAL IN A SAFE PLACE FOR FUTURE CONSULTATION WHENEVER REQUIRED.**

The technical documentation supplied is an integral part of the machine; therefore, if the equipment is sold all the documentation must be consigned with it.

## 2.0 INTENDED USE

The “**Automatic digital Inflator**” is an electronic device projected to be utilized exclusively for manual inflation and deflation of vehicle wheels. “**Truck**” version is assigned to inflate and deflate truck wheels. The inflator can't be utilized to inflate bicycle wheels or other small-size wheels.

### 2.1 Personnel training

**The equipment may only be used by specifically trained, authorised personnel.**

In view of the importance of the operations needed to carry out procedures efficiently and safety, the personnel using the machine must be correctly trained, so that they acquire the information required for operation in line with the guidelines provided by the manufacture.

A careful reading of this instruction manual for use and maintenance and a short period of training with skilled personnel can be an enough preventive preparation.

This appliance must only be used for the purpose for which it is specifically designed.

Any other use is to be considered as improper and thus unreasonable.

**The manufacturer can not be considered responsible for any damage caused by improper, incorrect or unreasonable use.**

## 3.0 SAFETY DEVICES

- Red emergency button with two stable positions. It can be pressed to stop the inflation procedure in case of an anomaly, a failure or any other hazard. Because of this button excludes only the mechanical part, continuing the inflation can damage the device.

#### 4.0 GENERAL SAFETY RULES

- **Any tampering with or modification of the equipment not authorised in advance by the manufacturer relieves the latter of liability for damage consequent on or related to such operations.**
- Removal of or tampering with safety devices is a breach of European Regulations on safety.
- Use of the fitting is only permitted in places free from **explosion** or **fire** hazard and in **dry places under cover**.
- Original spare parts and accessories should be used.
- Installation must be carried out by qualified staff, in full accordance with the instructions provided below.
- Check that no dangerous situations arise during operation; if malfunctions are noted, stop the machine immediately, and contact your authorised dealer's after sales service.
- The machine's dimensions allow the operator to check that the working area around the machine is unobstructed and free of people, that there are no potentially hazardous items in the vicinity and that there is no oil present, in order to prevent possible damage to the tyre. Moreover, oil spills on the floor represent a hazard for the operator.
- The operator must wear appropriate working clothing, protective goggles, gloves and mask to avoid damage deriving from hazardous dust emissions, and if necessary provide protection against back strain caused by lifting heavy parts. Dangling objects such as bracelets must not be worn, long hair must be suitably protected, and shoes must be suitable for the type of operation to be carried out.
- During inflation, do not lean on or over the tyre; during bead insertion, keep hands well away from the tyre and the edge of the rim.

#### 5.0 PACKAGING AND HANDLING FOR TRANSPORT

The device is supplied completely assembled ready to be fastened on work station.

#### 6.0 UNPACKING

**Carry out the unpacking, assembly, lifting and installation operations described below with care. Failure to comply with these recommendations may cause damage to the equipment and put the operator at risk.**

The packaging components (plastic bags, expanded polystyrene, nails, screws, pieces of wood, etc.) must not be left within reach of children because they are potentially dangerous.

Take these materials to the special collection points if they are pollutant or not biodegradable.

#### 7.0 ASSEMBLY AND COMMISSIONING

After freeing the various components from the packaging check them for damage and anomalies, then comply with the instructions below for assembly of the components, following the series of illustrations enclosed for reference.

##### 7.1 Accessories inside the packaging

There is a cardboard box inside the packing, containing all the accessories (for assembling and equipping the machine).

Check that all the parts listed are included:

##### G1000A46 - G1000A47 "ASSEMBLY ON TYRE DEMOUNTING DEVICE"

Code	Description	N.
1163000	Fe 6,4x13x2 washer	4
0250000	TCEI M6x16 screw	4
3483000	Pipe	1
0396000	T-8 union	1
4096000	D.8 plastic plug	1
6145000	8x6 blue pipe L=780	1

##### GIDF + GIDCOL "ASSEMBLY ON COLUMN"

Code	Description	N.
5844000	Screw anchor M8	1
1163000	Fe 6,4x13x2 washer	4
0250000	TCEI M6x16 screw	4
1813000	M6 flange nut	4
6033000	Column	1
3483000	Pipe	1
0396000	T-8 union	1
4096000	D.8 plastic plug	1
6145000	8x6 blue pipe L=780	1

## 7.2 Assembly procedure GIDW

To assemble the device keep the following instructions:  
(See **Fig. 4**)

1. Remove the package.
2. After that the device is free from the package, check overall and installment dimensions.
3. Carry out the wall drilling at scheduled height and fix all with appropriate screw anchors #9275000 (1) (See **Fig. 4**), screws #9297000 (3) and washers #9298000 (2) supplied in equipment.

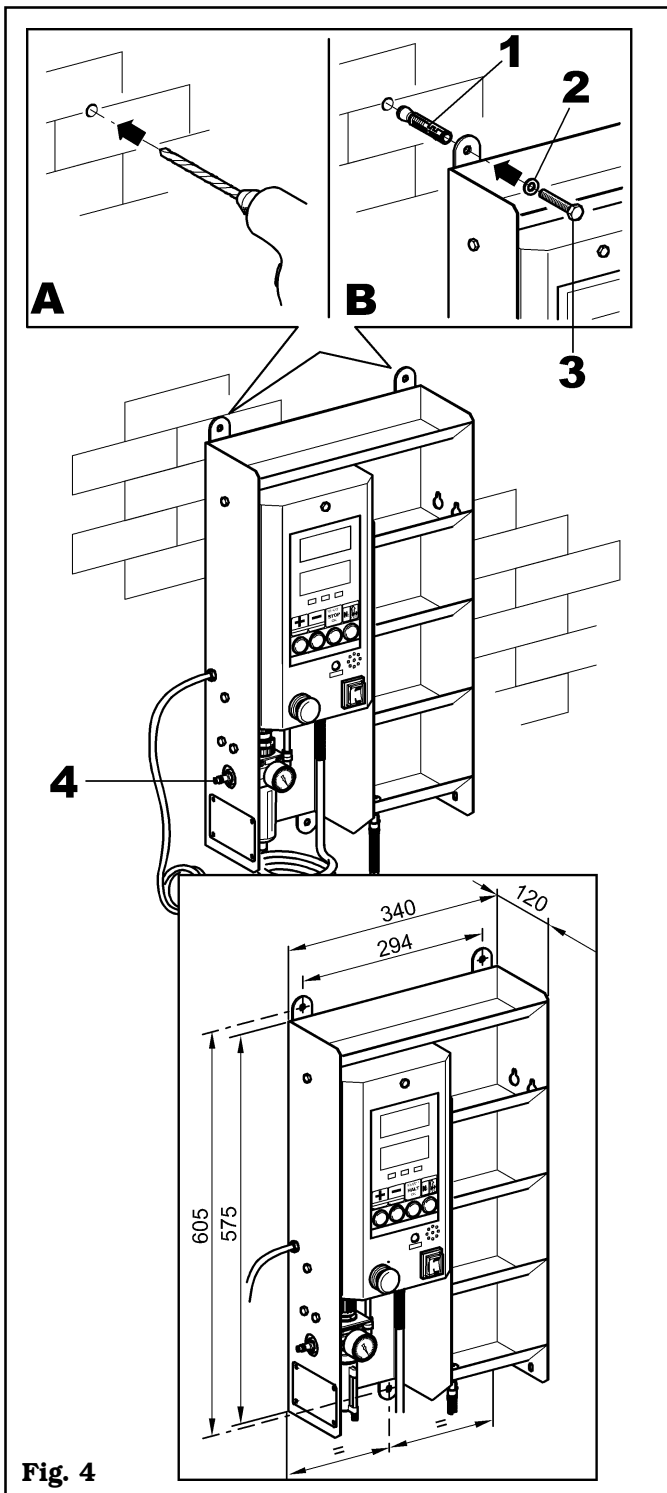

**Fig. 4**

4. Connect the mains pneumatic feeding through the union located on device side (**pos. 4**).

## 7.3 Assembly procedure GIDF + GIDCOL (fixing on column)

To assemble the device keep the following instructions:  
(See **Fig. 5**)

1. Remove the package.
2. Screw down **not completely** the screws (9) #0250000 to the pile utilizing the nuts #1813000 (10).
3. Fasten to the ground the pile #6033000 (1) with the appropriate screw anchor #5844000 (2) supplied in equipment.
4. Fix the device (3) through appropriate slots (7), to the pile.
5. At the end secure all through screws #0250000 (5) and washers #1163000 (6) and nuts #1813000 (4) supplied in equipment.

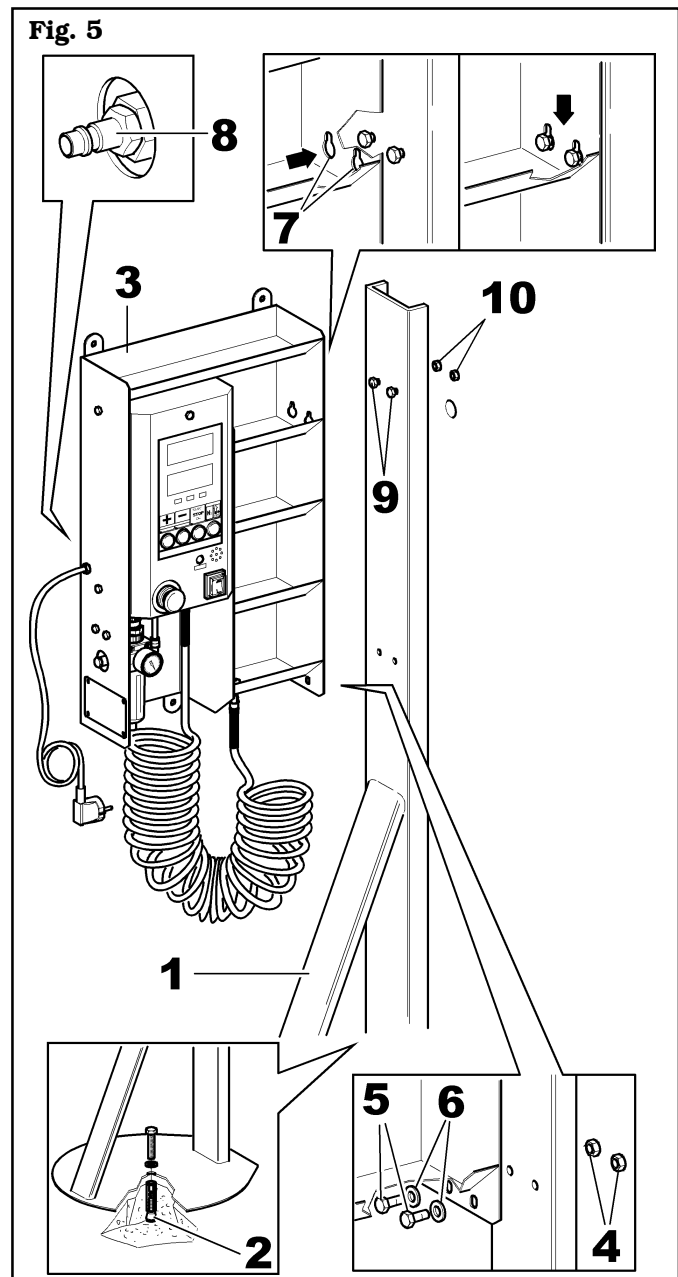

**Fig. 5**

6. Connect the mains pneumatic feeding through the union located on device back side (**8**).

#### 7.4 Assembly procedure G1000A46 - G1000A47 (fixing on tyre demounting device)

To assemble the device keep the following instructions: (See **Fig. 6**)

1. Remove the package.
2. Screw down not completely the screws #0250000 (6) to the machine.
3. Fasten the device (1) to the machine through appropriate slots (4).
4. At the end secure all through screws #0250000 (3) and washers #1163000 (2) supplied in equipment.

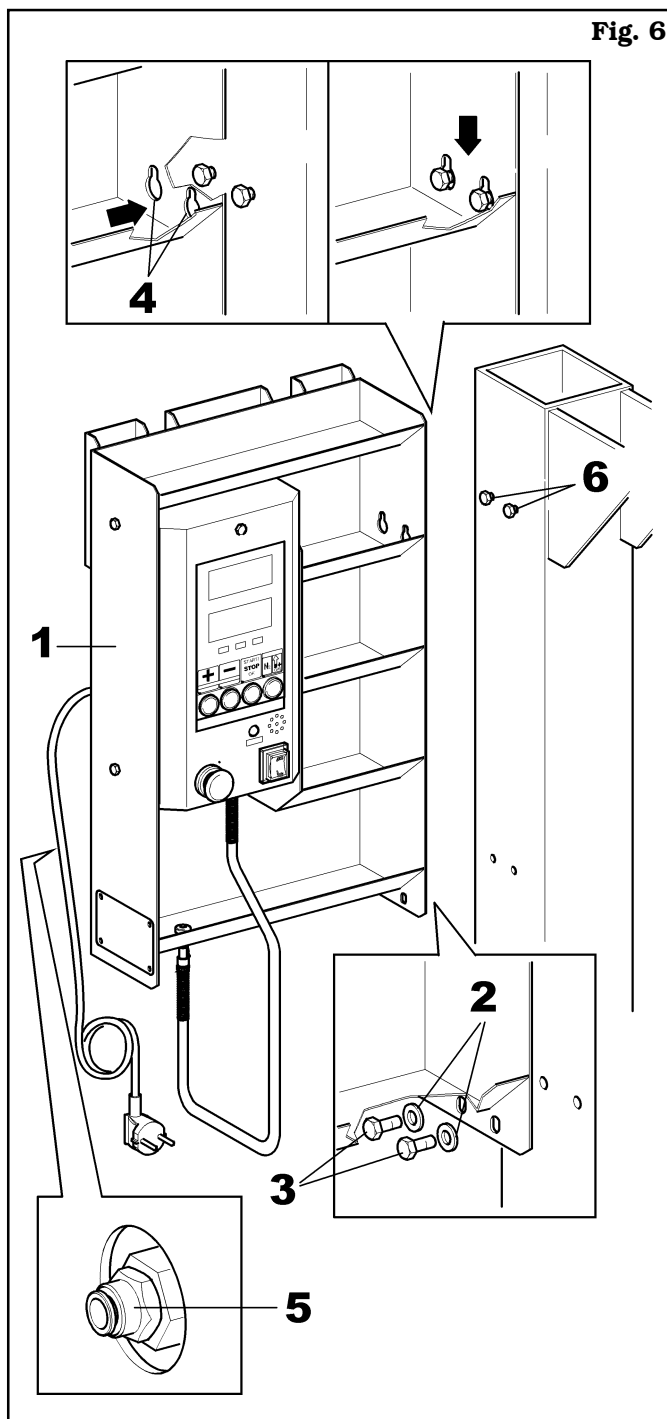

**Fig. 6**

5. Connect the mains pneumatic feeding through the union located on device back side (5).

#### 7.5 Connecting procedure of automatic digital Inflator to tyre demounting device

1. Disconnect the tyre demounting device from all its power supply parts.
2. Remove the protection cover on the left side (frontal view of the machine)(1).
3. Disjoint the red hose (2) from the fitting of the inflating pedalboard and plug the fitting using a red plug #4096000 (3) supplied in equipment.
4. Disjoint the blue hose (4) from the fitting located in the middle of regulator-oiler filter unit.
5. Connect to the available fitting of regulator-oiler filter (5) the blue hose #3483000 (6) and joint to this one the "T" fitting #3960000 (7) supplied in equipment.
6. Connect to the two available ends of the "T" fitting the blue hose (4A) previously disjoined from the regulator-oiler filter unit and the blue hose #6145000 (8) coming from automatic digital inflator.
7. Assemble the left lateral protection guard (1).
8. Finally connect the tyre demounting device to its power sources.

**WHEN ASSEMBLY OPERATIONS ARE OVER CHECK ALL MACHINE FUNCTIONS.**

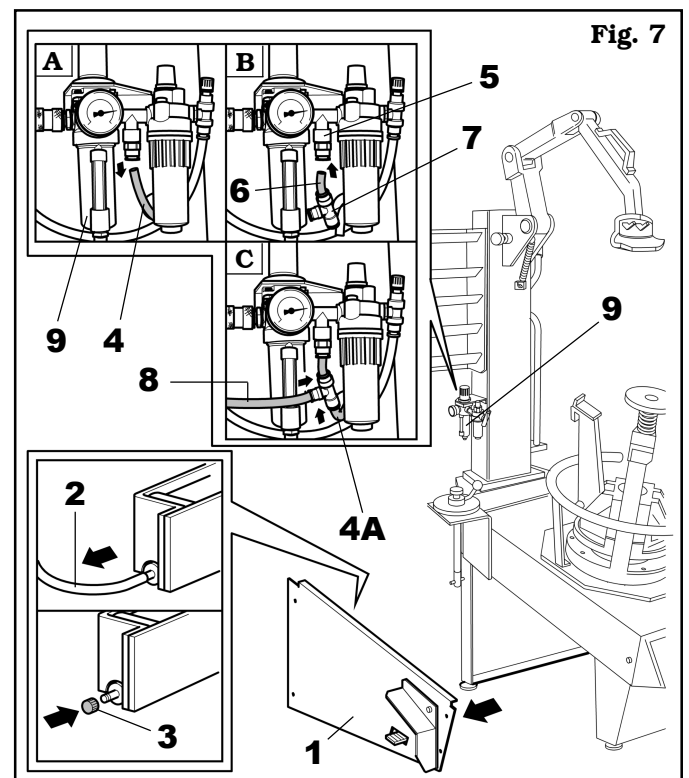

**Fig. 7**

If the tyre demounting device is equipped with TUBELESS inflating system this one will be able to be utilized pushing the inflation pedal until its bottom. If not, the pedal will be not operating.



## 8.0 LIGHTING

The machine does not require its own lighting for normal working operations.

However, it must be placed in an adequately lit environment. For correct lighting, use lamps having total power 800/1200 Watt as envisaged by UNI 10380.

## 9.0 CONTROLS

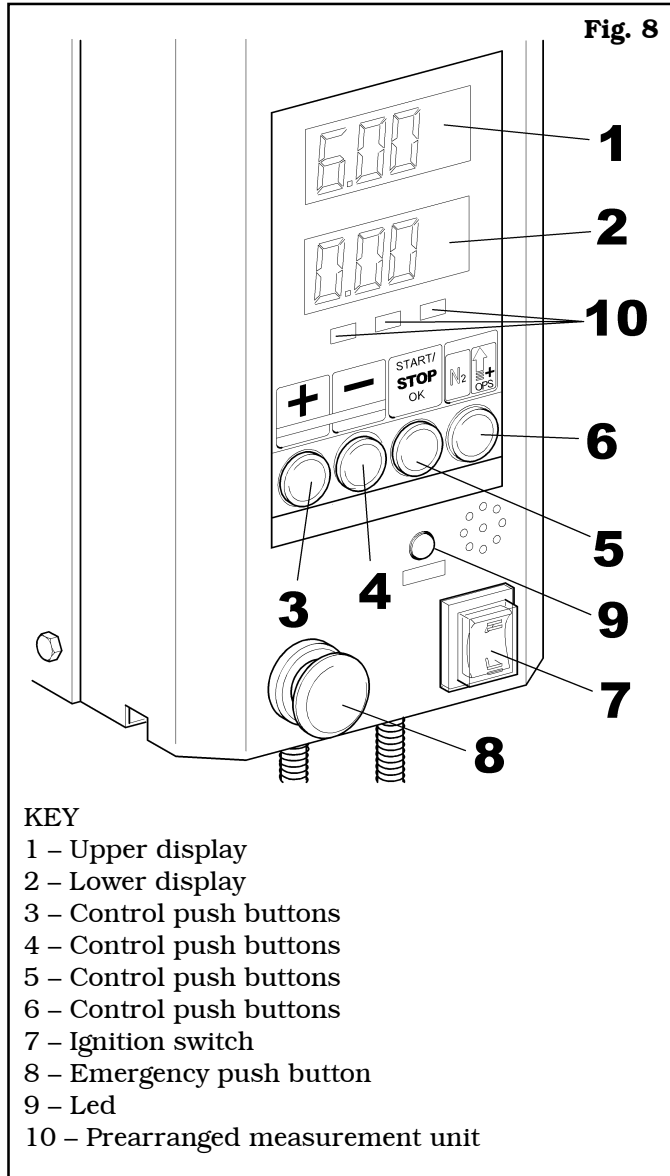

In device front part (**Fig. 8**) two liquid crystal displays and four keys are located. The display of the upper part (**pos. 1**) permits to visualize the pressure value prearranged for inflation. The lower display (**pos. 2**) has a double function:

- display the pressure reached during the inflation operation;
- display of the overpressure of beading-in or number of tyre washing cycles with nitrogen.

The key "+" (**pos. 3**) increases the inflation pressure values of bead breaking overpressure and of the number of washing cycles with nitrogen.

The key "-" (**pos. 4**) decreases the inflation pressure values of bead breaking overpressure and of the number of washing cycles with nitrogen.

The key **OPS/N<sub>2</sub>** (**pos. 6**) allows to set by using the keys + and - the required overpressure or the number of washing cycles of the tyre with nitrogen (also until their reset). When it is kept pushed and the program "Car" is selected, it allows to slowly increase the pressure of the tyre until a maximum of 6,5 bar (94,5 PSI) for its beading-in (**CONTROLLED BEADING-IN OF RUN-FLAT**).

The key **START/STOP/OK** (**pos. 5**) has the function of starting and stopping the inflation and of confirming the beading-in overpressure or the number of the entered cycles with nitrogen.

Pushing the two keys + and - at the same time to switch from the program "Car" to the program "Truck" and vice versa.

When the program "Truck" is in process the red led (**pos. 9**) will be lighted up indicating that the inflation device will manage high pressures of inflation.

The measuring unit (Bar, Kpa or PSI) of the utilized pressure is lighted up and visible in **pos. 10**.

**NOTE:** the measuring unit of pressure can't be modified by the user but it is prearranged by the manufacturer.

## 10.0 USING THE DEVICE

### 10.1 Environmental conditions of use

The device is prearranged to work at a temperature included between -10°C and +50°C.

The use of dry compressed air is recommended.

For the pressure of utilization for the various models refer to chapter 13.0 "Technical data".



**THE MANUFACTURER ACCEPTS NO LIABILITY FOR ANY DAMAGE CAUSED BY FAILURE TO COMPLY WITH THE INSTRUCTIONS GIVEN ABOVE, WHICH WILL CAUSE THE WARRANTY CONDITIONS TO BECOME NULL AND VOID!**

### 10.2 Inflating a tyre



**TYRE INFLATION IS A DANGEROUS OPERATION. ALWAYS INFLATE TYRES IN THE STRICTEST OBSERVANCE OF THE FOLLOWING INSTRUCTIONS.**



**IT'S RECOMMENDED THE INFLATION OR THE BEADING-IN OF THE TYRE INSIDE APPROPRIATE CAGES OR SHIELDS.**

Connect the machine to electric and pneumatic feeding sources, therefore act the start switch (**Fig. 8 Pos. 7**).



**BEFORE ACTING THE DEVICE THROUGH THE START KEY, GRASP THE INFLATION PIPE TERMINAL KEEPING IT FAR FROM FACE; AFTER THE IGNITION, WAIT FOR AN AIR BLOW.**

**NOTE:** If the emergency push button is used (**Fig. 8 Pos. 8**) it's required to put it in standard position (pulling it toward the operator) and it's recommended to switch off and on the device before carrying out new inflation operations.

### 10.3 Selection of the inflation program

The device is able to perform two different programs according to the requirements of the user:

- a program "Car" utilizable for the inflation of car tyres until a maximum pressure of 4,2 bar (61 PSI) and, exceptionally, for the beading-in at higher pressures of the run-flat tyres;
- a program "Truck" to perform the inflation of truck wheels until a maximum of 10 bar (145 PSI).

When the program "Truck" is in progress the red led (**Fig. 8 Pos. 9**) will be lighted up showing that the inflating device will manage high pressures of inflation.

The pushing at the same time of the keys + and - allows to switch from the program "Car" to the program "Truck" and vice versa.

**NOTE:** in the automatic digital inflator, for the fixing on tyre demounting device, the performing of the program "Truck" is disenabled: the device therefore allows to inflate a tyre until maximum 4,2 bar (61 PSI).

### 10.4 Handling of the tyre



**THE LIFTING OF WEIGHT MORE HEAVY THAN 25 KG (FOR AN ADULT MEN WITH GOOD HEALTH CONDITIONS) INVOLVES A STRESS FOR THE ARTICULATIONS AND A REMARKABLE EFFORT OF THE LOIN VERTEBRAS.**

The operator who handles the tyre must observe the following indications:

- Put on individual safety devices ( at least shoes and gloves against accidents).
- Carry out carefully, as possible, the rotation of the tyre on the floor.
- In case of lifting, ensure that the weight is included within the safety ergonomic parameters previously described.
- In case the weight is more heavy than the permissible maximum one it's opportune to act using particular precautions like the utilization of lifting devices or the help (if it's possible for the weight in object) of another person with adequate health conditions.

## 10.5 Inflation procedure

- 1) Set on the upper display the required value of pressure by using the keys "+" and "-".
- 2) Push the key (**START/STOP/OK**).
- 3) Connect the inflation pipe terminal to tyre valve, the inflation will start automatically.

In case the wheel is completely deflated, push another time the key "**START/STOP/OK**".

- 4) An acoustic signal informs that the inflation operation is finished.
- 5) For the inflation in sequence of more tyres at the same pressure the inflation terminal can be repetitively connected to the valve of each tyre and each inflation will be automatically started as shown in point 3.

### 10.5.1 Inflation of wheels for truck

The inflation device is equipped, only in the program "Truck", with a system for "automatic control of tyre volume" that helps to prevent possible danger situations caused by an error in the data setting by the user.

The inflation device, following a initial blow with short duration, determines what is the capacity of the tyre and decides if enabling the consent for the inflation or not. If the tyre is too small to be inflated at high pressures, the inflating device will be set to alarm condition and signal on the display the relative error ("**Err Vol**") emitting at the same time a sound and automatically stopping the inflation.

To enable the inflation again it's possible to carry out one of the two following operations:

- a) disconnect the inflation terminal of the tyre and push **START/STOP/OK**.
- b) in case the interrupted inflation is intentionally wanted to be anyway carried out, for example because a tyre of a light "Truck" is being inflated at a pressure of 5 bar (the tyre has a value that can be compared to the one of a car tyre, but it must be inflated at high pressures), it's possible to restart the inflation at the set pressure pushing at the same time the keys **START/STOP/OK** and **OPS/N<sub>2</sub>**.  
Once this inflation is over, exceptionally enabled, the control of tyre volume will be restored for the next inflation.



**THIS OPERATION MUST BE CARRIED OUT ONLY BY SKILLED AND OPPORTUNELY TRAINED PERSONNEL.**

If the electronic inflating device is connected to an inflation cage of the manufacturer, it will inflate the tyre only until 1,5 bar (22 PSI) with the doors of the cage opened. Once the cage is closed, the electronic inflating device allows to reach upper pressures. If the cage is not installed, or the doors of the cages are closed from the beginning, the inflation toward the final pressure will be carried out without any interruption.

## 10.6 Setting of beading-in overpressure and of the number of tyre washing cycles with nitrogen

In both the programs of the inflating device, acting on the key **OPS/N<sub>2</sub>**, it's possible to set the value of overpressure and the number of tyre washing cycles for the inflation with nitrogen. The adjustment of the overpressure-OPS is the function that permits to over-inflate the tyre over its rated pressure on road to allow the tyre to perfectly adhere on the rim.

The inflation with nitrogen performed with washing cycles of the tyre consists of inflating and deflating the tyre several times before leading it to the rated pressure to obtain optimum purities (close to 95 %) inside the tyre.

The maximum settable overpressure is equal to 1,5 bar (22 PSI).

To nullify the overpressure it's required to reset its value.

The number of tyre washing cycles with nitrogen which can be set is included between 0 and 6.

### 10.6.1 How to modify the prearranged values

- 1) Pushing more times the key **OPS/N<sub>2</sub>** the value of overpressure and the number of tyre washing cycles actually in use (previously prearranged) can be alternatively displayed. On the upper display the following writing is displayed:

0 P 5      or      n 2

and in the lower one the correspondent value of overpressure or the number of tyre washing cycles with nitrogen are displayed.

- 2) Push the keys "+" or "-" to modify the values on the lower display.
- 3) Push **START/STOP/OK** to confirm the value on the display and escape or wait for a few seconds to automatically escape from the setting phase of the values without storing them.

**NOTE:** setting a **OPS** value different from zero the value of **N<sub>2</sub>** is automatically reset and vice versa.

### 10.6.2 Functioning of the inflating device

During the operation of inflation with overpressure, the values of rated pressure on the upper display and of true pressure on the lower display blink. When the true pressure, increased of the overpressure value, is reached, an acoustic signal will inform that the tyre will be deflated until the rated pressure of inflation. If the sum of the required final pressure and of the overpressure exceeds the maximum pressure manageable by the inflating device with that type of program selected (4,2 bar (61 PSI) in the program "Car" and 10 bar (145 PSI) in the program "Truck"), the actual overpressure utilized during the inflation will be reduced in order to not exceed the maximum limit of the inflating device.

During the washing cycle the upper display shows the number of the current washing cycle, the lower one (blinking) shows the pressure reached second by second inside the tyre.

In the program "Truck" each washing cycle consists of bringing the tyre until 3 bar (43,5 PSI) and then deflating it until 0,2 bar (3 PSI).

Each washing cycle in the program "Car" consists of bringing the tyre until 2 bar (29 PSI) and then deflating it until 0,2 bar (3 PSI).

### 10.7 Procedure for controlled beading-in of run-flat tyres (function activated only in the program "Car")

This operation must be carried out only by skilled personnel opportunely trained to follow the instructions given by the manufacturer.

It's better to carry out this operation utilizing the appropriate inflation cage.

Keeping the key **OPS/N<sub>2</sub>** pushed it's possible to manually and intentionally deliver air until the tyre is brought to pressures higher than 4,2 bar (61 PSI).

This operation of **controlled beading-in of run-flat tyres** is necessary to bead-in run-flat tyres particularly rigid.

During this phase of beading-in the red led (**fig. 8 pos. 9**) blinks to remember that, even if the program "Car" is activated, dangerous pressures are being reached. In this phase an acoustic signal is also emitted.

During the air delivery, on the upper display no writing is displayed. Lifting for a short time the finger from the key **OPS/N<sub>2</sub>** it's possible to check the pressure reached by the tyre on the lower display.

Pushing again the key **OPS/N<sub>2</sub>** the continuous delivery of air restarts while releasing it definitively the tyre is suddenly deflated to the inflation pressure previously prearranged and the inflating device switches to its normal programming "Car" limited in pressure at 4,2 bar (61 PSI).

If at the release, even if only temporary, of the key **OPS/N<sub>2</sub>** the inflating device senses a pressure in the tyre  $\geq 6,5$  bar (94,5 PSI), the tyre will be automatically led to a lower pressure than this value.

In case the inflating device is connected to an inflation cage of the manufacturer, keeping the key **OPS/N<sub>2</sub>** pushed, the closing of both doors will be electronically ensured when the pressure value exceeds the 1,5 bar (22 PSI), otherwise the inflation will be stopped.

### 10.8 Checking of the actual pressure measured (for the annual inspection and the checking of device calibration)

- Switch off the device by using the master switch.
- Switch on the device again keeping the two external keys **+** and **OPS/N<sub>2</sub>** pushed at the same time. The inflation device will show the measured pressure with a resolution of 0,01 bar. The user therefore can compare the accuracy of the pressure measured by the device to the one detected by a test equipment.

**The device set to this mode doesn't work as an automatic inflating device.**

- Switching off and on the unit will return to normally work.

## 11.0 ROUTINE MAINTENANCE



**BEFORE CARRYING OUT EVERY ROUTINE MAINTENANCE INTERVENTION DISCONNECT THE MACHINE FROM ITS FEEDING SOURCES.**

To keep the machine at top efficiency and in good working order, the instructions given below must be followed, carrying out the daily or weekly cleaning procedure and the routine servicing procedure every week. Routine cleaning and maintenance must be carried out by authorised staff in accordance with the instructions provided below:

- Use a vacuum cleaner to remove any tyre dust and waste materials from the machine.
- **NEVER BLOW WITH COMPRESSED AIR.**
- Never use solvents to clean the pressure regulator.

### 11.1 GIDW version

- Drain the condensate from the pressure regulator reservoir **every day (pos. 1)**; for this aim push the valve **(pos. 2)** located on regulator base to discharge the accumulated condensate (**Fig. 9**).

**Fig. 9**

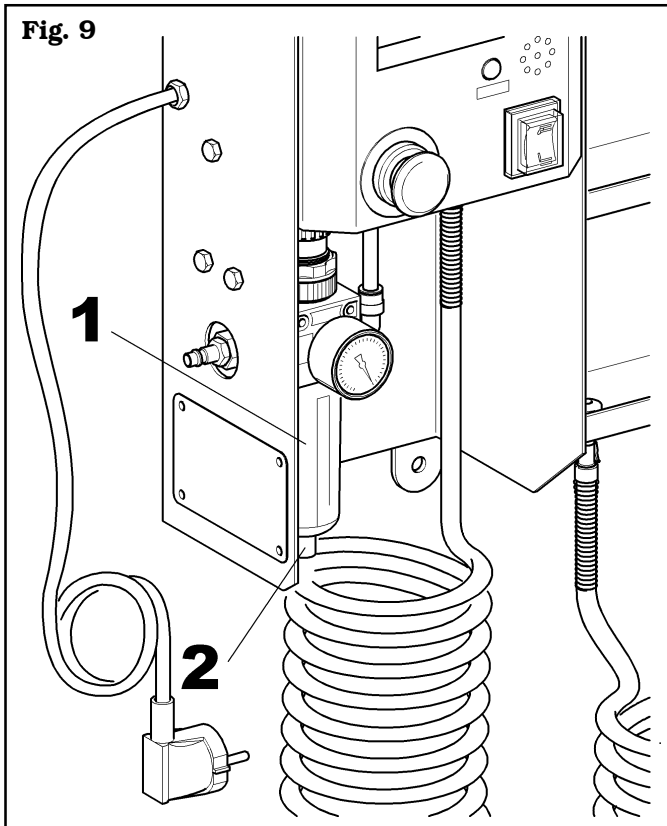

### 11.2 GIDF + GIDCOL version on column

- Carry out **daily** the drainage of the condensate of the reservoir **(pos. 1)** of the pressure control filter; for this purpose push the valve **(pos. 2)** placed on the base of the regulator to discharge the accumulated condensate (**Fig. 10**).

**Fig. 10**

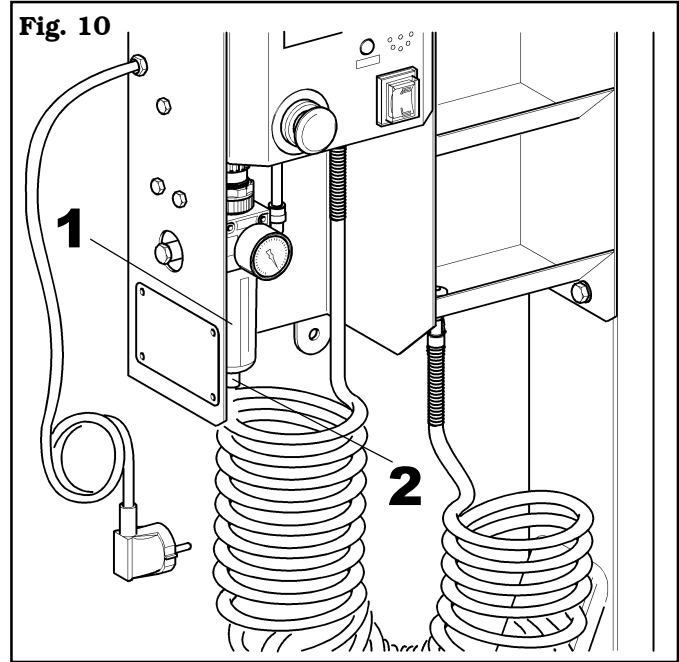

### 11.3 G1000A46 - G1000A47 version on tyre demounting device

- Carry out **daily** the drainage of the condensate of the reservoir (**Fig. 7 pos. 9**) of the pressure control filter.
- Periodically (better once a month) carry out a complete control check for the correspondence between controls themselves and scheduled actions.



**THE MANUFACTURER ACCEPTS NO LIABILITY FOR DAMAGE DERIVING FROM FAILURE TO COMPLY WITH THE ABOVE INSTRUCTIONS, WHICH MAY ALSO CAUSE THE WARRANTY TO BECOME NULL AND VOID!!**

**12.0 TROUBLESHOOTING TABLE**

<b>Trouble</b>	<b>Errors</b>	<b>Possible cause</b>	<b>Remedy</b>
Err	HA	Hardware error	Call assistance.
Err	SOft	Software error	Call assistance.
Err	ini	Errors at starting: <ul style="list-style-type: none"> <li>• At starting the pipe is connected to a tyre.</li> <li>• At starting the pipe is obstructed.</li> <li>• At starting the emergency pushbutton is pushed.</li> <li>• At starting the delivery pressure is not enough.</li> </ul>	Act consequently to remove the error cause.
Err	inFL	The inflating device can't inflate. <ul style="list-style-type: none"> <li>• Inflation terminal not properly connected to the tyre (it leaks) or completely disconnected.</li> <li>• Inflation pressure of the tyre set too close to the infeed one of the device.</li> </ul>	Act consequently to remove the error cause.
Err	OUtF	The inflating device can't deflate. <ul style="list-style-type: none"> <li>• The inflation terminal is disconnected.</li> <li>• The emergency pushbutton is pushed.</li> </ul>	Act consequently to remove the error cause.
Err	Air	Troubles with compressed air pipeline. <ul style="list-style-type: none"> <li>• Infeed pressure not enough.</li> <li>• Pipe throttled.</li> <li>• The emergency pushbutton is pushed.</li> </ul>	Act consequently to remove the error cause.
Err	Vol	Attempt of tyre inflation at a too high pressure.	1 - Change the type of tyre. 2 - Enable the inflation procedure again according to what reported in § 10.5.1.

### 13.0 TECHNICAL DATA

Model	Recommended air feeding (bar)	Feeding maximum pressure (bar)	Inflation maximum pressure (bar)
GIDW	7-12,5 (101,5-181,5 PSI)	12,5 (181,5 PSI)	10 ("Truck" program) (145 PSI)
GIDF + GIDCOL assembly on column	7-12,5 (101,5-181,5 PSI)	12,5 (181,5 PSI)	4,2 ("Car" program) (61 PSI)
G1000A46 - G1000A47 assembly on tyre demounting device	7-10 (101,5-145 PSI)	10 (145 PSI)	4,2 (only "Car" program) (61 PSI)

Permissible maximum error: ..... **0,08 bar (0÷4 bar)**  
**0,16 bar (4÷10 bar)**

Noise: ..... **< 70 dB**

Electric feeding (checkable on rating plate): ..... **230V 50 Hz (\*)**  
**115V 50 Hz (\*)**

Electric absorption: ..... **ca. 18 VA**

(\*) **According to models**

### 13.1 Dimensions

Model	Dimensions			Weight
	H	L	W	Kg
GIDW	640	345	120	~13
GIDF + GIDCOL assembly on column	1470	375	360	~24
G1000A46 - G1000A47 assembly on tyre demounting device	640	345	120	~13

### 14.0 STORING

In case of storing for long periods, disconnect the main power supply and take measures to protect the machine from dust build-up.

### 15.0 SCRAPPING

If this machine is to be taken permanently out of service, it must be made inoperative by removing the pressure connection lines.

The inflation cage must be considered as a special waste and dismantled dividing it into homogeneous parts. Dispose of parts in accordance with the local laws in force.

### 16.0 NAMEPLATE DATA

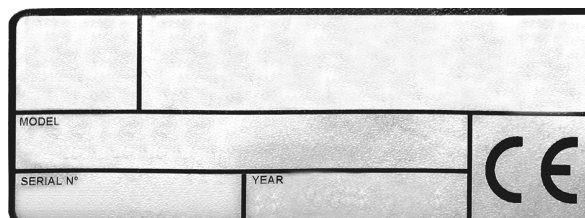

## 7900-R006-1

**GIDW - GIDF - GIDCOL  
G1000A46 - G1000A47**

- I** 17.0 LISTA DEI COMPONENTI
- GB** 17.0 LIST OF COMPONENTS
- D** 17.0 TEILELISTE
- F** 17.0 LISTE DES PIÈCES DETACHÉES
- E** 17.0 LISTA DE PIEZAS



**GLI ESPLOSI SERVONO SOLO PER L'IDENTIFICAZIONE DELLE PARTI DA SOSTITUIRE. LA SOSTITUZIONE DEVE ESSERE EFFETTUATA DA PERSONALE PROFESSIONALMENTE QUALIFICATO.**



**THE DIAGRAMS SERVE ONLY FOR THE IDENTIFICATION OF PARTS TO BE REPLACED. THE REPLACEMENT MUST BE CARRIED OUT PROFESSIONALLY QUALIFIED PERSONNEL.**



**DIE ZEICHNUNGEN DIENEN NUR ZUR IDENTIFIZIERUNG DER ERSATZTEILE. DIE ERSETZUNG MUß DURCH QUALIFIZIERTES PERSONAL ERFOLGEN.**



**LES DESSINS NE SERVENT QU'À L'IDENTIFICATION DES PIÈCES À REMPLACER. LE REMPLACEMENT DOIT ÊTRE EFFECTUÉ PAR UN PERSONNE PROFESSIONNELLEMENT QUALIFIÉ.**



**LOS DIBUJOS EN DESPIECE SIRVEN ÚNICAMENTE PARA IDENTIFICAR LAS PIEZAS QUE DEBEN SUSTITUIRSE. LA SUSTITUCIÓN DE PIEZAS DEBE EFECTUARLA EXCLUSIVAMENTE PERSONAL PROFESIONALMENTE CUALIFICADO.**

- Per eventuali chiarimenti interpellare il più vicino rivenditore.
- For any further information please contact your local dealer.
- Für Rückfragen wenden Sie sich bitte an den nächsten Wiederverkäufer.
- Pour tout renseignement complémentaire s'adresser au revendeur le plus proche.
- En caso de dudas, para eventuales aclaraciones, póngase en contacto con el distribuidor más próximo.



**SOMMARIO-SUMMARY-INHALT  
SOMMAIRE-SUMARIO**

**Tavola N°1.....2**

GIDW  
GIDW  
GIDW  
GIDW  
GIDW

**Tavola N°3 .....6**

GIDF + GIDCOL MONTAGGIO SU COLONNA  
GIDF + GIDCOL ASSEMBLY ON COLUMN  
GIDF + GIDCOL MONTAGE AUF SAULE  
GIDF + GIDCOL MONTAGE SUR COLONNE  
GIDF + GIDCOL MONTAJE EN COLUMNA

**Tavola N°2 .....4**

G1000A46 - G1000A47 MONTAGGIO SU SMONTAGOMME  
G1000A46 - G1000A47 ASSEMBLY ON TYRE DEMOUNTING DEVICE  
G1000A46 - G1000A47 MONTAGE AUF REIFENABMONTIERER  
G1000A46 - G1000A47 MONTAGE SUR DEMONTE-PNEUS  
G1000A46 - G1000A47 MONTAJE EN DESMONTAGOMAS

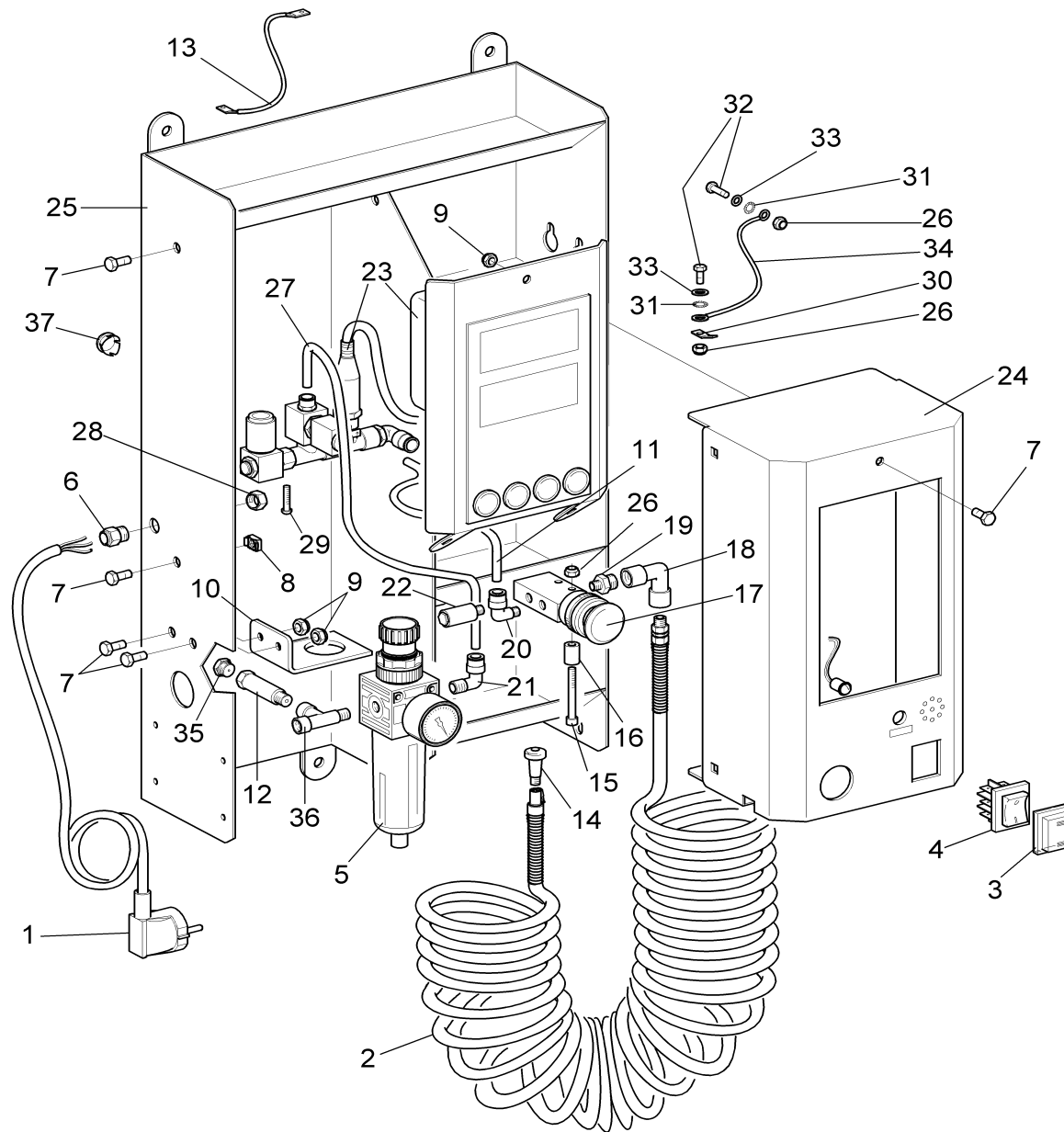

**LISTA DEI COMPONENTI - LIST OF COMPONENTS - TEILELISTE  
LISTE DES PIÈCES DÉTACHÉES - LISTA DE PIEZAS**

**Tavola N°1**

GIDW  
GIDW  
GIDW  
GIDW  
GIDW

**Pag. 2 di 7**

GIDW - GIDF - GIDCOL  
G1000A46 - G1000A47

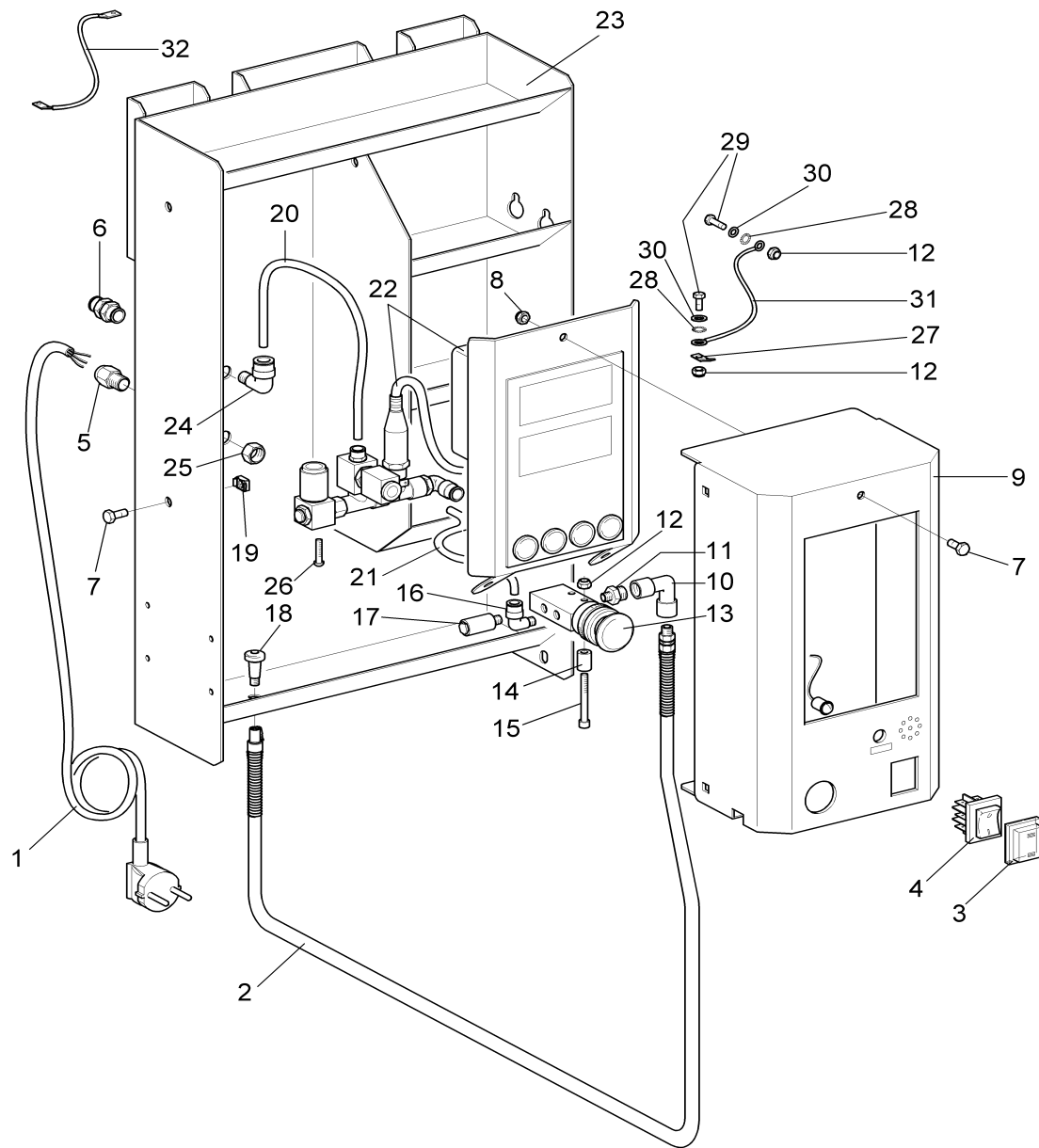

**LISTA DEI COMPONENTI - LIST OF COMPONENTS - TEILELISTE  
LISTE DES PIÈCES DÉTACHÉES - LISTA DE PIEZAS**

**Tavola N°2**

G1000A46 - G1000A47 MONTAGGIO SU SMONTAGOMME  
G1000A46 - G1000A47 ASSEMBLY ON TYRE DEMOUNTING DEVICE  
G1000A46 - G1000A47 MONTAGE AUF REIFENABMONTIERER  
G1000A46 - G1000A47 MONTAGE SUR DEMONTE-PNEUS  
G1000A46 - G1000A47 MONTAJE EN DESMONTAGOMAS

**Pag. 4 di 7**

GIDW - GIDF - GIDCOL  
G1000A46 - G1000A47

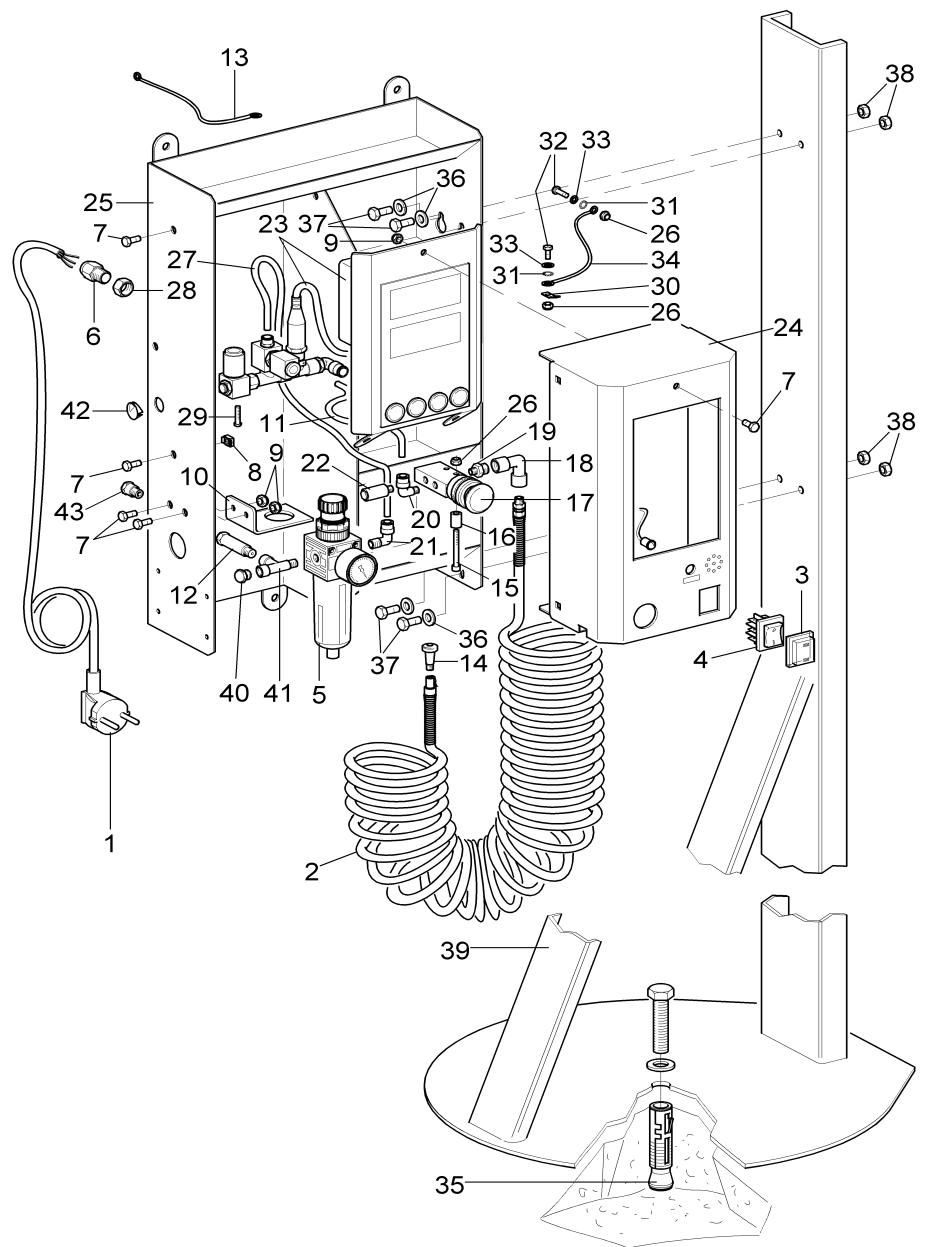

**LISTA DEI COMPONENTI - LIST OF COMPONENTS - TEILELISTE**  
**LISTE DES PIÈCES DÉTACHÉES - LISTA DE PIEZAS**

**Tavola N°3**

GIDF + GIDCOL MONTAGGIO SU COLONNA  
 GIDF + GIDCOL ASSEMBLY ON COLUMN  
 GIDF + GIDCOL MONTAGE AUF SAULE  
 GIDF + GIDCOL MONTAGE SUR COLONNE  
 GIDF + GIDCOL MONTAJE EN COLUMNA

**Pag. 6 di 7**

GIDW - GIDF - GIDCOL  
 G1000A46 - G1000A47