

**8162 Series - Easy Fit LED Courtesy Lamp**

<b>Light Source</b>	LED
<b>Installation</b>	Pre-wired with Tinned Marine Cable
<b>Operating Voltage</b>	Multivolt™ 12 / 24V DC
<b>Power Consumption</b>	0.5W
<b>Degree of Protection</b>	Completely Sealed 

**Wiring Colour Coding**

LED modules are polarity conscious. Reverse polarity will not damage this product but will inhibit its function. Hella recommends wire connections be soldered and heat shrink tubing applied to seal the joint.

Cable Colour	Connect to	Power Consumption
Black	Negative (-)	
White/Colour	Power (+)	0.5W

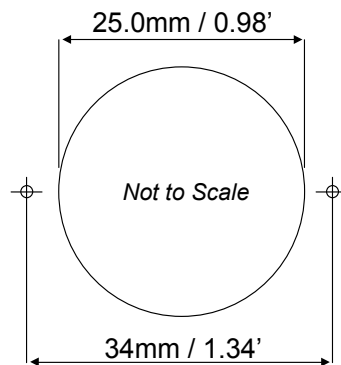

**Note:** Recommended screw size (4G X 3/8 Pan Head)

**TIP: Cap Fitment**

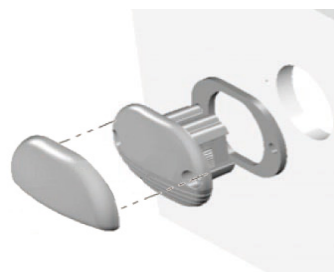

After mounting lamp align cap with top edge and push firmly to secure

958 315-43 V01

**Congratulations !** The product you have selected comes from Hella - one of the world's leading manufacturers of lighting products. The product comes with a 5 year warranty from end user purchase covering faults in materials, components or workmanship.

In the unlikely event that you should experience a confirmed warranty related problem with your purchase, Hella will, at its discretion, either repair, replace or refund the purchase price of the product. Warranty services may be obtained by returning the product within the warranty period to the Hella Dealer where the product was originally purchased.

This warranty is in addition to and does not preclude any other rights or remedies available to the consumer under any local legislation related to the provision of goods or services.

Our goods come with guarantees that cannot be excluded under the Australian Consumer Law. You are entitled to a replacement or refund for a major failure and for compensation for any other reasonably foreseeable loss or damage. You are also entitled to have the goods repaired or replaced if the goods fail to be of acceptable quality and the failure does not amount to a major failure.

This warranty does not cover:

1. Claim/s as a result of normal wear and tear or of any modifications and / or alterations to the product in any shape or form.
2. Claim/s as a result of non-compliance of the assembly, service and operating instructions and/or any unfit or improper use.
3. Any expenses incurred in the process of making the claim.

Note: For lamps sold in Australia warranty services are provided by: Hella Australia Pty Ltd, 54-76 Southern Rd, Mentone VIC 3194  
Customer Service 1800 061 729 [www.hella.com/hella-au/21.html](http://www.hella.com/hella-au/21.html)

For general comments about Hella marine products please email [techfeedback@hellamarine.com](mailto:techfeedback@hellamarine.com) or visit [www.hellamarine.com](http://www.hellamarine.com)

