

Brake Tester BD 6xx (without BD 66x)



en Planning file
Brake tester for passenger vehicles

Contents

1.	Assembly requirements	3
1.1	General information	3
	1.1.1 Delivery	3
	1.1.2 Utilities	3
	1.1.3 Measuring units	3
1.2	Foundation	3
1.3	Electrical system	4
1.4	Wall fastening	4
1.5	Outdoor assembly	4
1.6	Miscellaneous	4
2.	Overview of the item references	5
3.	Plans of pit and installation	7
3.1	BD 6xx with wall bracket	7
	3.1.1 Plan of pit	7
	3.1.2 Installation plan	11
3.2	BD 6xx with column	15
	3.2.1 Plan of pit	15
	3.2.2 Installation plan	19
3.3	BD 6xx with assembling case	23
4.	Load diagram	26
5.	Auxiliary equipment	27
5.1	Edge Protection	27
5.2	Support	27
5.3	Assembling case	27

1. Assembly requirements

1.1 General information

Following assembly requirements have to be fulfilled before a technician starts to assembly or rewire the device:

! The specifications given in this planning file are minimal requirements in order to guarantee a correct installation of the BD 6xx. According the implementation of the given specifications, special national regulations, directives and standards have to be taken in account!

The Beissbarth GmbH is not liable for defects according to nonobservance of national regulations.

! The reproduction, distribution and utilization of the construction plans as well as the communication of its contents to others without explicit authorization is prohibited. Offenders will be held liable for the payment of damages. All rights reserved in the event of the grant of a patent, utility model or design.

1.1.1 Delivery

The following components / materials are not included in the standard delivery capacity:

- Fitting frame / assembling case
- Support material
- Edge protection
- Plastic pipes

ii These components / materials can be ordered additionally as an option.

1.1.2 Utilities

To ease the assembly, the following utilities must be available:

- An appropriate lifting jack to bring the brake tester in the foundation.
- A draw wire to be laid in the empty pipes between the foundation and the display and between the foundation and the control cabinet.

1.1.3 Measuring units

Measuring unit	Conversion
1 ft	0,305 m
1 m	3,281 ft
1 inch	0,0254 m = 25,4 mm
1 m = 1000 mm	39,37 inch
1 cm = 0,01 m	0,394 inch
10 N	1 kgf

1.2 Foundation

Establish the foundation following the plan of pit.

! *Follow the instructions precisely!*

- The foundation must be laid on load-bearing soil and extend down to the frost line.
- The dimensions of the foundation must correspond with soil conditions.
- Concrete quality according to EN 206-1, with reinforcing steel mesh complying with max. test bed vehicle load.
- A draw wire is to be installed if pipes are laid.
- All dimensions on the drawing are minimum dimensions and allow for a tolerance of + 1cm.
- Surface level according to DIN 18202, Table 3, level tolerances line 4, column 5, distance = 15m. (Floor level to tolerance must be upheld 5m for and after the pit, taken from pit upper edge).
- Fix the mounting frame, edge protection etc. before concreting in order to avoid a buoying upwards or slipping of these devices during the concreting procedure.
- Positioning of an empty pipe DN70 between the foundation for the mechanics and the display.

! The empty pipe must be put with its underside on the floor.



Fig. 1: Assembling case concret-casted (example)

1.3 Electrical system

The local power connection 400V / 3Ph~N (230 V / 3 Ph~) must be directed to the main switch box, following the foundation plan.

! The electric connection to the machine (inlet) has to be executed by a local authorized electrician.

! Fuse Protection of the Power Supply
It is absolutely necessary to use a 3-pole circuit breaker of type "C" for the fuse protection of the power supply. Single circuit breakers are not permissible. Disregard of this notice can damage your test stand.

! When using the column, make sure that the feed under the stand takes place (see the plan of pit).

1.4 Wall fastening

In deliveries with wall bracket, make sure that the wall is suitable for the fastening (fastening anchor).

ii Special fastening anchor for pit walls or similar are not included in the delivery capacity.

1.5 Outdoor assembly

! For outdoor assembly, make sure that display and printer are protected from environment influences (rain, snow). Outdoor operation with a suitable rain shield and observation of the permissible temperature range is possible. Otherwise it is not possible to give a guarantee for eventual damages.

1.6 Miscellaneous

For repairing and restoring works on foundation and wires that exceed the delivered length of 15 meters, we will charge for time and extra material.

ii Addresses of german producers of permanent safety markings:

- Argelith Bodenkeramik H. Bitter GmbH
Postfach 1240
49145 Bad Essen
Tel. 0049-(0)5472-402-0
Fax. 0049-(0)5472-1512



Produkt: black / yellow glazed tile

<http://www.eco-select.de>

- Permalight Aktiengesellschaft
Hoher Holzweg 32
30966 Arnum
Tel. 0049- (0)5101-6263-0
Fax. 0049- (0)51051-5013
<http://www.permalight.com>

2. Overview of the item references

The following table gives an overview on the reference numbers used in the pit and installation plans.

Nr	Description	Note
1	Minimum requirements for the concrete quality: <ul style="list-style-type: none"> • Outdoor area (without de-icing salt exposure) • Outdoor area (with de-icing salt exposure) • Indoor area (without any particular exposure) 	Strength properties / type of exposure: <ul style="list-style-type: none"> • C 25/35 XC4, XF1 • C 30/37 LP XC4, XD2, XF4 • C 20/25 XC3
2	Top surface of finished floor	
3	PVC pipe DN70	 Do not lay pipe in tight curves. Prepare cable pulls to centre of pit.
4	Site requirements: Mains feed cable	5 x 2,5 mm ² , if mains voltage 3 x 400 V (3 Ph, N, PE) fuse protection 3 x 25 A / C-3pole or 4 x 4 mm ² , if mains voltage 3 x 230 V (3 Ph, PE) fuse protection 3 x 32 A / C-3pole
5	Fixing of the Power Supply Box on the wall	Mounting kit Order number: 935 603 247 4 dowels S6 (Fa. Fischer) 4 screws DIN 96 4x40
6	Fixing of the Power Supply Box on the column	4 screws DIN 84 M4x12
7	Water draining pipe	 Water draining pipe as required.
8	Leveling kit	Order number: 935 603 159 Only required for brake testers with integrated weight cells.
9	Mounting kit suspension tester (clamping units)	Order number: 935 662 012
10	Mounting kit suspension tester (dowels)	Order number: 935 694 001
11	Resting surface	The testline must be levelled at all resting surfaces (max. tolerance 2 mm).
12		
13	Hazard areas	Must be marked with yellow and black stripes in accordance with DIN 4844 T1.
14	Analogue display	
15	IPB-beams	The customer is responsible for obtaining 2 I-beams IPB 100 x 100 x 2500 mm long centric drilled Ø = 70mm.
16	PC-Station	Or customer-PC
17	Fitting frame ST 600	Order number: 935 634 019 Must be ordered and concreted by customers.
18	Direction of travel	
19	Fitting frame ST 600 V2.0 with compensation plate	Order number: 935 634 052 Must be ordered and concreted by customers.
20	Wall on site	
21	Structurals dimension in cm	Make a careful on site check of all foundation work.
22	Power supply 230V for PC	
23	Support frames	<ul style="list-style-type: none"> • Only for brake testers with integrated weight cells. • 1 set order number: 935 603 109 If you ordered weight cells: order 1 set • Must be ordered and concreted by customers.
24	Distance support frame	Only for weight cells.
25	Distance height compensation with weight cells	

Nr	Description	Note
26		
27	Edge protection BD 5xx, BD 6xx	Order number: 935 604 008 Optional accessory, must be ordered and concreted by customers.
28	Edge protection SA 640, SA 680	Order number: 935 624 005 Optional accessory, must be ordered and concreted by customers.
29	Edge protection BD 6xx, TL/SL	Order number: 935 694 001 Optional accessory, must be ordered and concreted by customers.
30	Alternative bottom attachment (dowels)	See plan: 925 690 024
31		
32	Fixing of the column	Fixing kit, order number: 935 603 229 4 dowels S12 (Fa. Fischer), 4 screws DIN 571-10 x 80 4 washers DIN9021-10,5
33	Fixing of the wall bracket	Fixing kit, order number: 935 603 229 4 dowels S12 (Fa. Fischer), 4 screws DIN 571-10 x 80 4 washers DIN9021-10,5 See load diagramm chapter 4
34	Assembling case for BD series	Assembling case complete, order number: 935 604 179 Optional accessory, must be ordered and concreted by customers.
35	Fixing of the control box	Fixing kit, order number: 935 603 250 4 dowels S8 (Fischer) 4 screws DIN 96, 5 x 50
36	Ramp for mb 60 - DC	2 x ramp, order number: 935 603 304
37	Assembling case for test lane mtl 69 - DC / stl 70 - DC	Assembling case complete, order number: 935 603 305 Optional accessory, must be ordered and concreted by customers.
38	Assembling case for TL/SL test lane	Assembling case complete, order number: 935 604 170 Optional accessory, must be ordered and concreted by customers.
39	Edge protection mss 8400	Order number: 935 834 010 Must be ordered and concreted by customers.
40	Edge protection BD 66x	Order number: 935 604 229 Optional accessory, must be ordered and concreted by customers.
41	Edge Protection BD 7xx	Order number: 935 874 012 Optional accessory, must be ordered and concreted by customers.
42	Assembling case for test lane with SAT 69x	Order number: 1 691 602 241 Optional accessory, must be ordered and concreted by customers.
43	Edge Protection for test lane with SAT 69x	Order number: 1 691 602 242 Optional accessory, must be ordered and concreted by customers.
50	Plane concrete slab	
51	Fill with concrete up to top edge of the U-profile. Pay attention to the cant to the middle profile.	
52	Fill with concrete all around up to the top edge of the assembling case.	
53	Fill with concrete up to top edge of the L-profile. Pay attention to the cant to the water drain.	
54		
55	Plan of pit drawn without assembly case.	
56	Plan of pit drawn with assembly case.	

Tab. 1: Overview item references

3. Plans of pit and installation

3.1 BD 6xx with wall bracket

3.1.1 Plan of pit

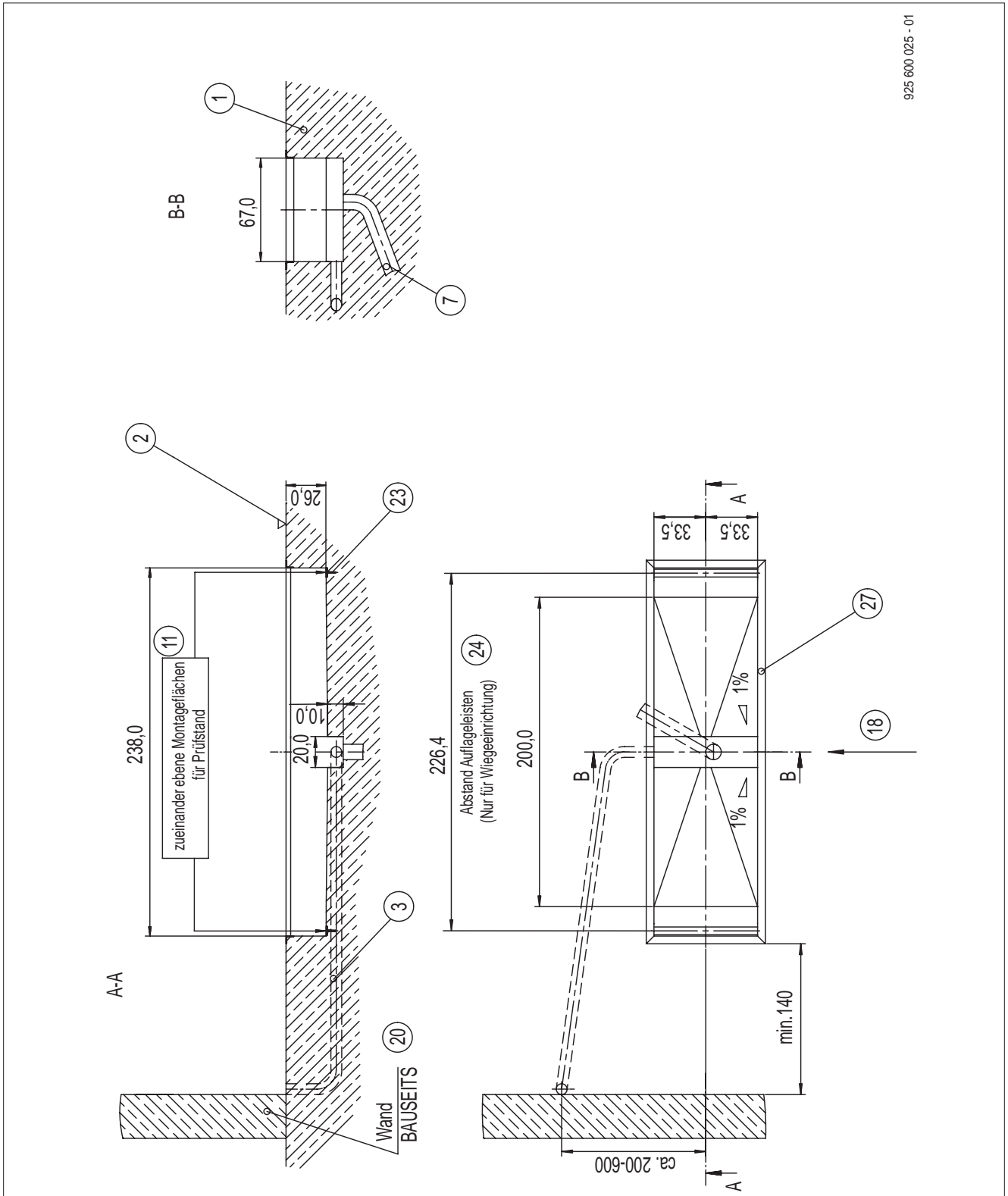
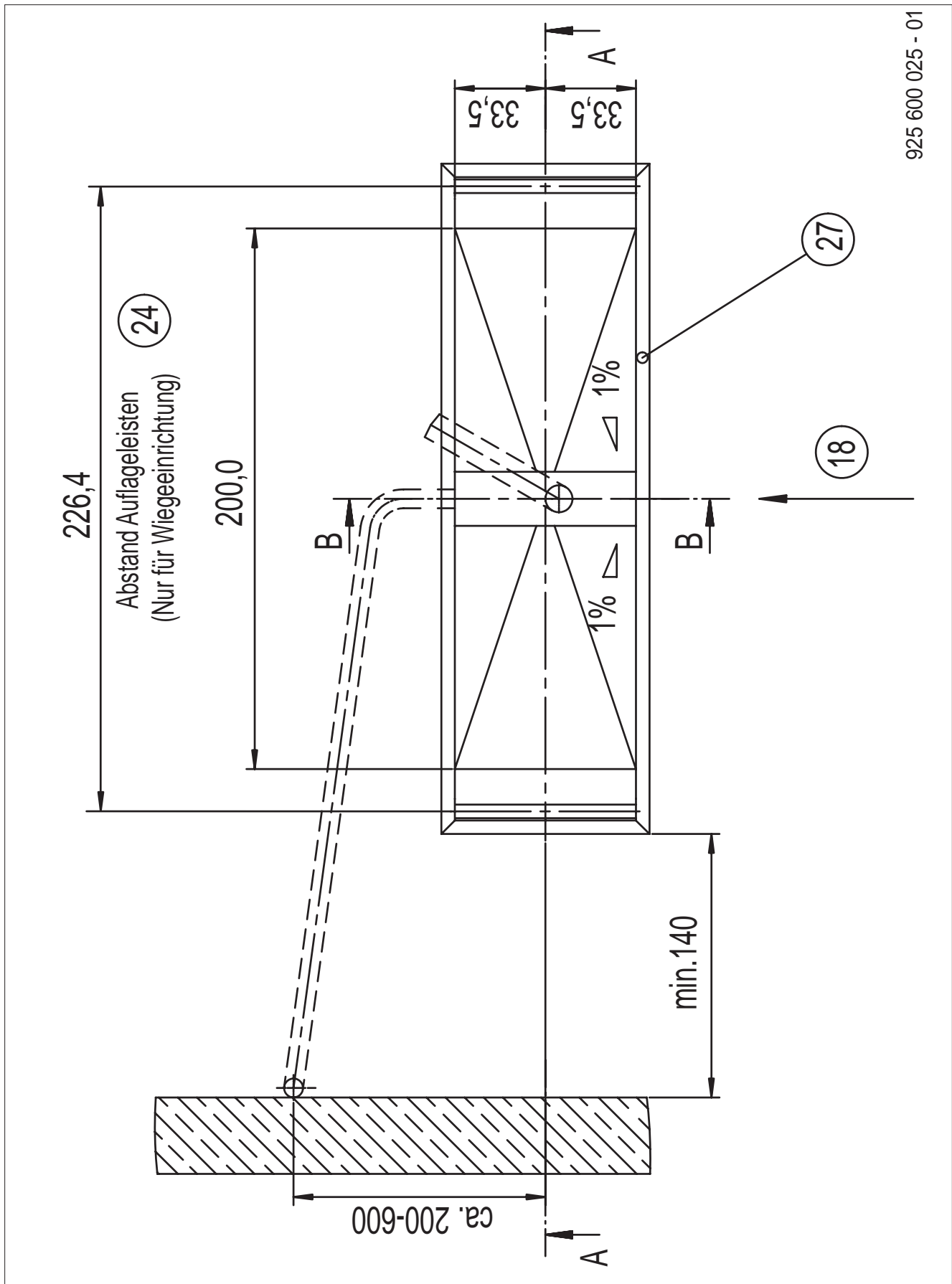
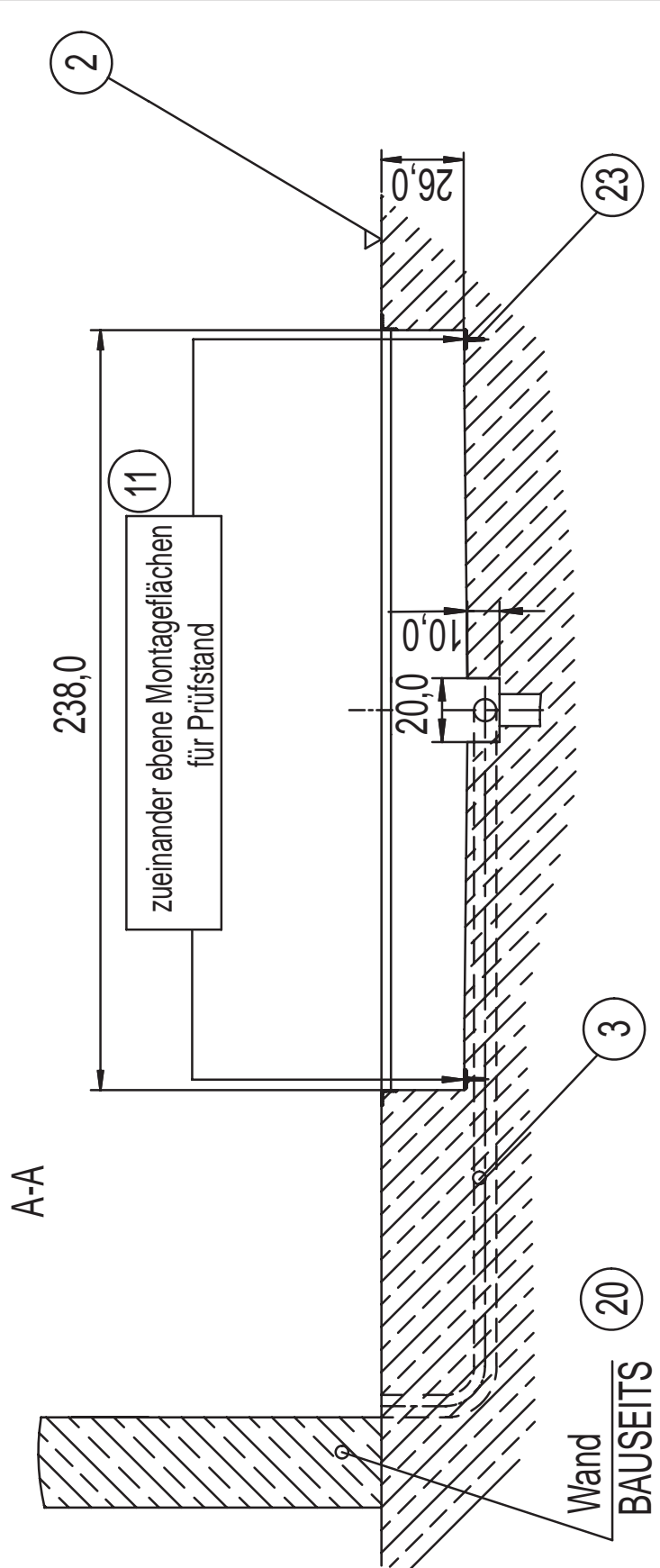

Fig. 2: Plan of pit BD 6xx with wall bracket - Overview
Item references see chapter 2



925 600 025 - 01

Fig. 3: Plan of pit BD 6xx with wall bracket - Ground plan
Item references see chapter 2



925 600 025 - 01

Fig. 4: Plan of pit BD 6xx with wall bracket - Sectional view A-A
 Item references see chapter 2

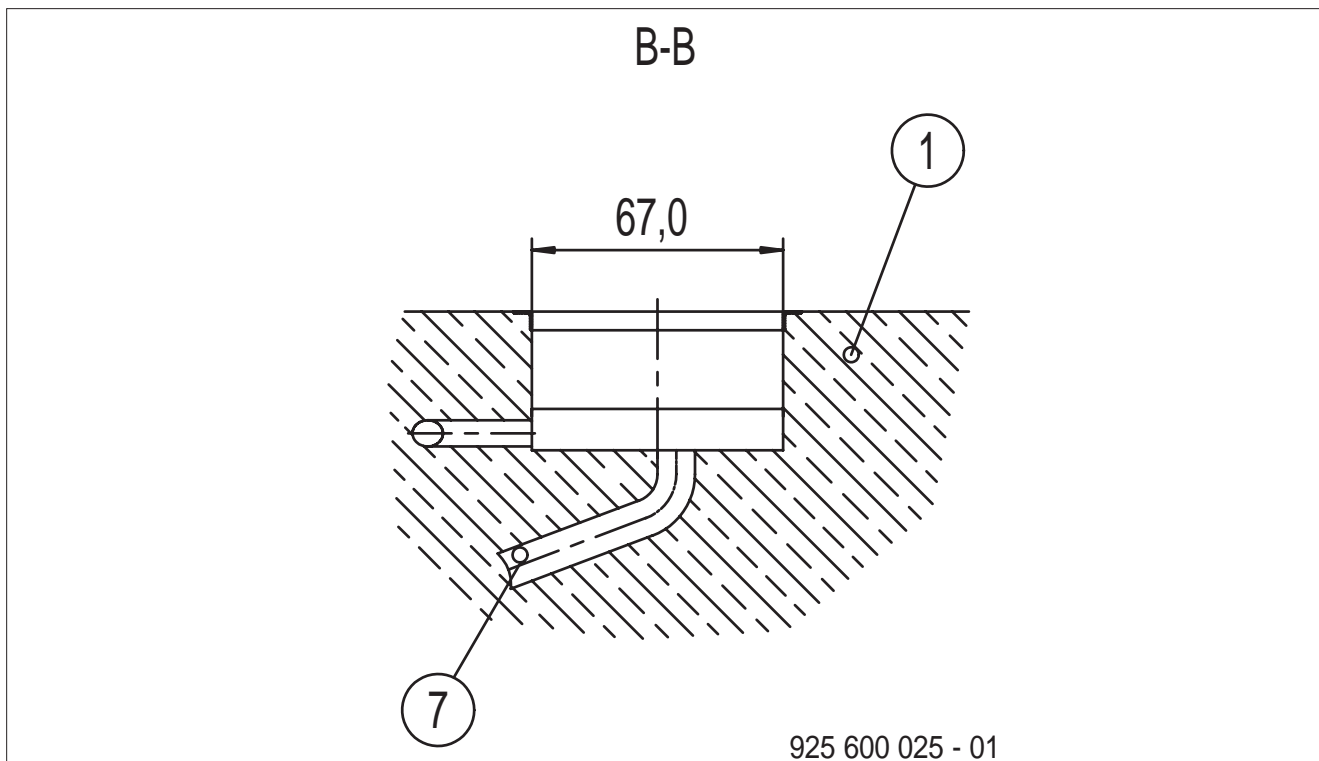
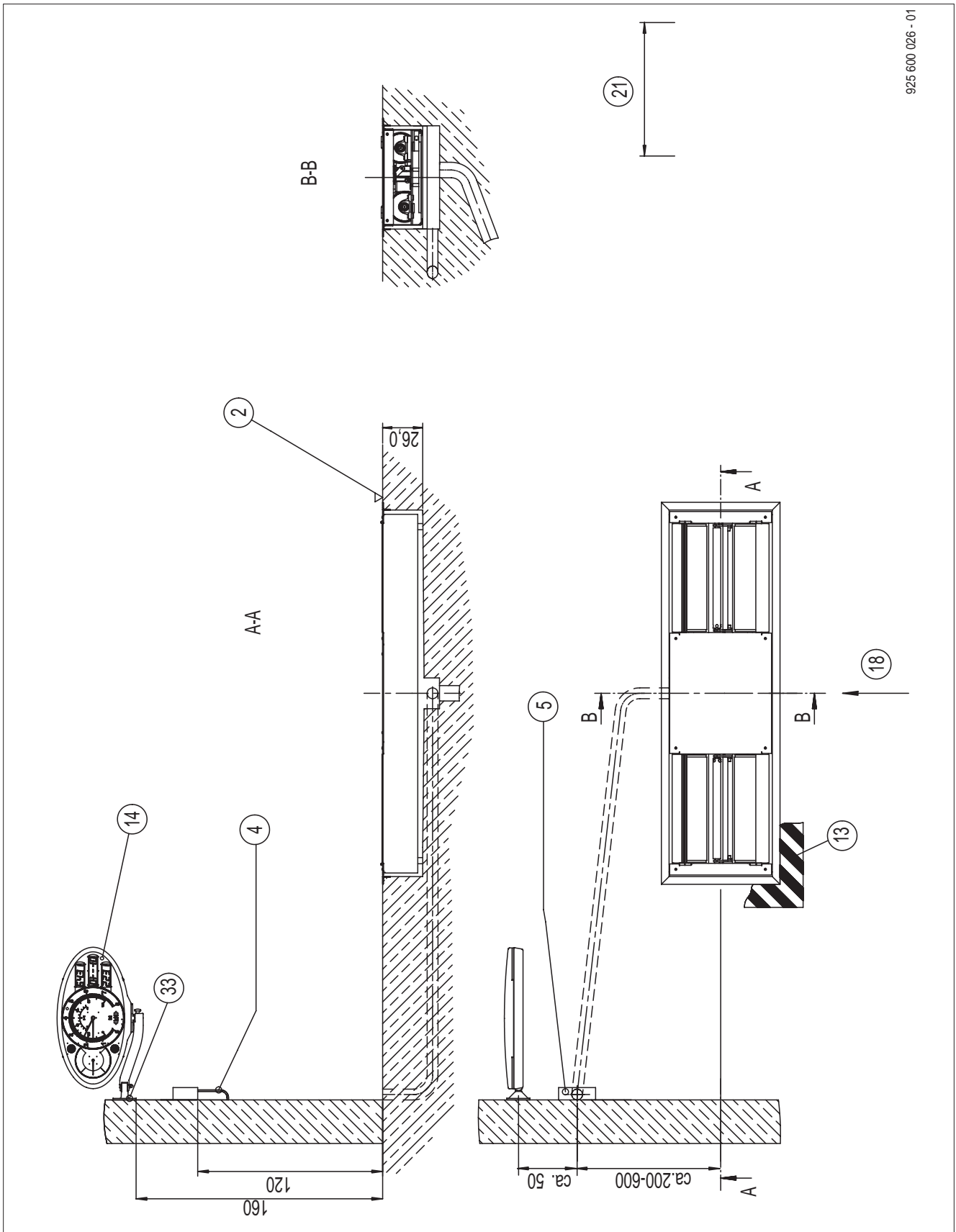

Fig. 5: Plan of pit BD 6xx with wall bracket - Sectional view B-B
Item references see chapter 2

3.1.2 Installation plan



925 600 026 - 01

Fig. 6: Installation plan BD 6xx with wall bracket - Overview
 Item references see chapter 2

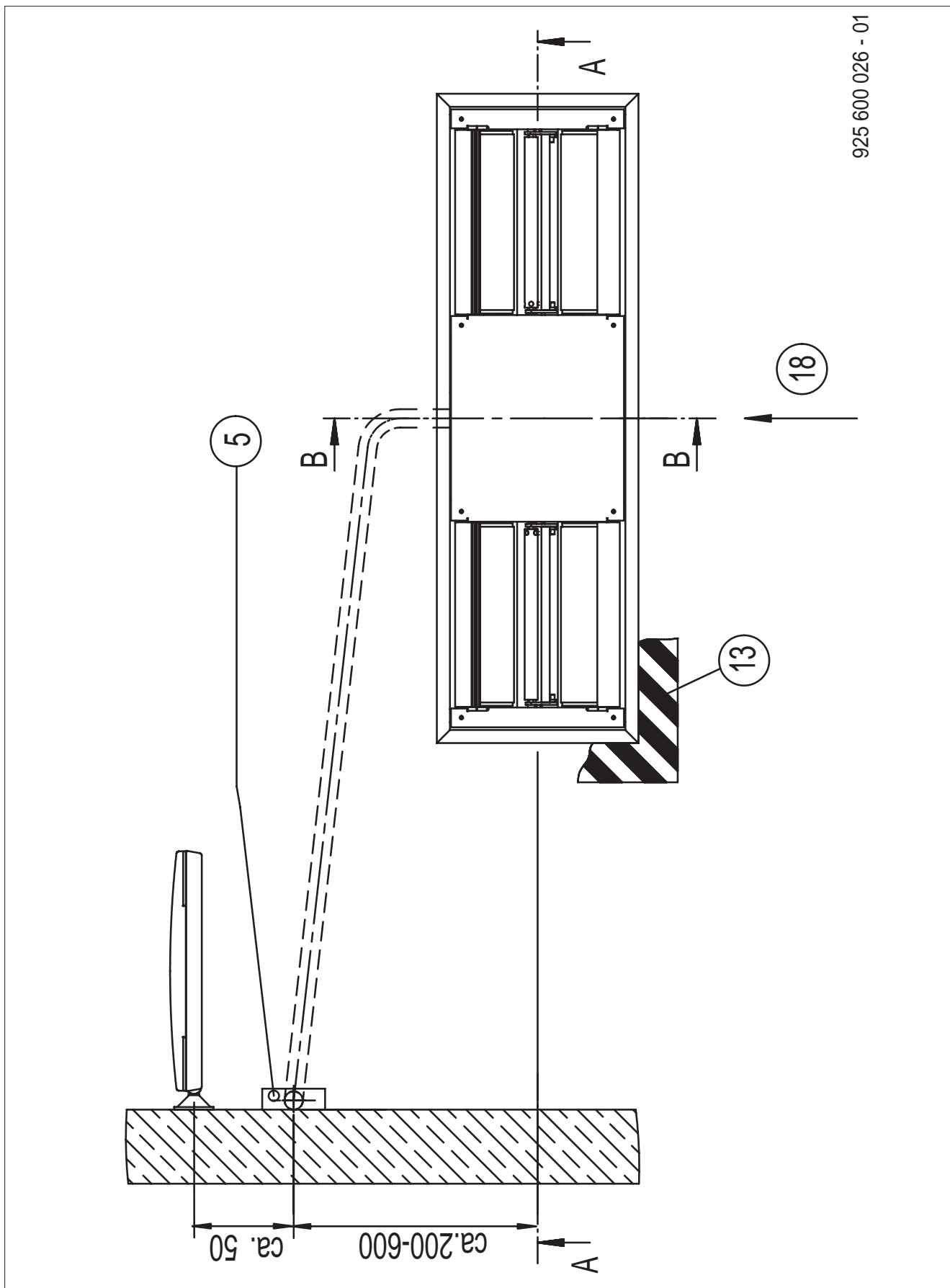

Fig. 7: Installation plan BD 6xx with wall bracket - Ground plan
Item references see chapter 2

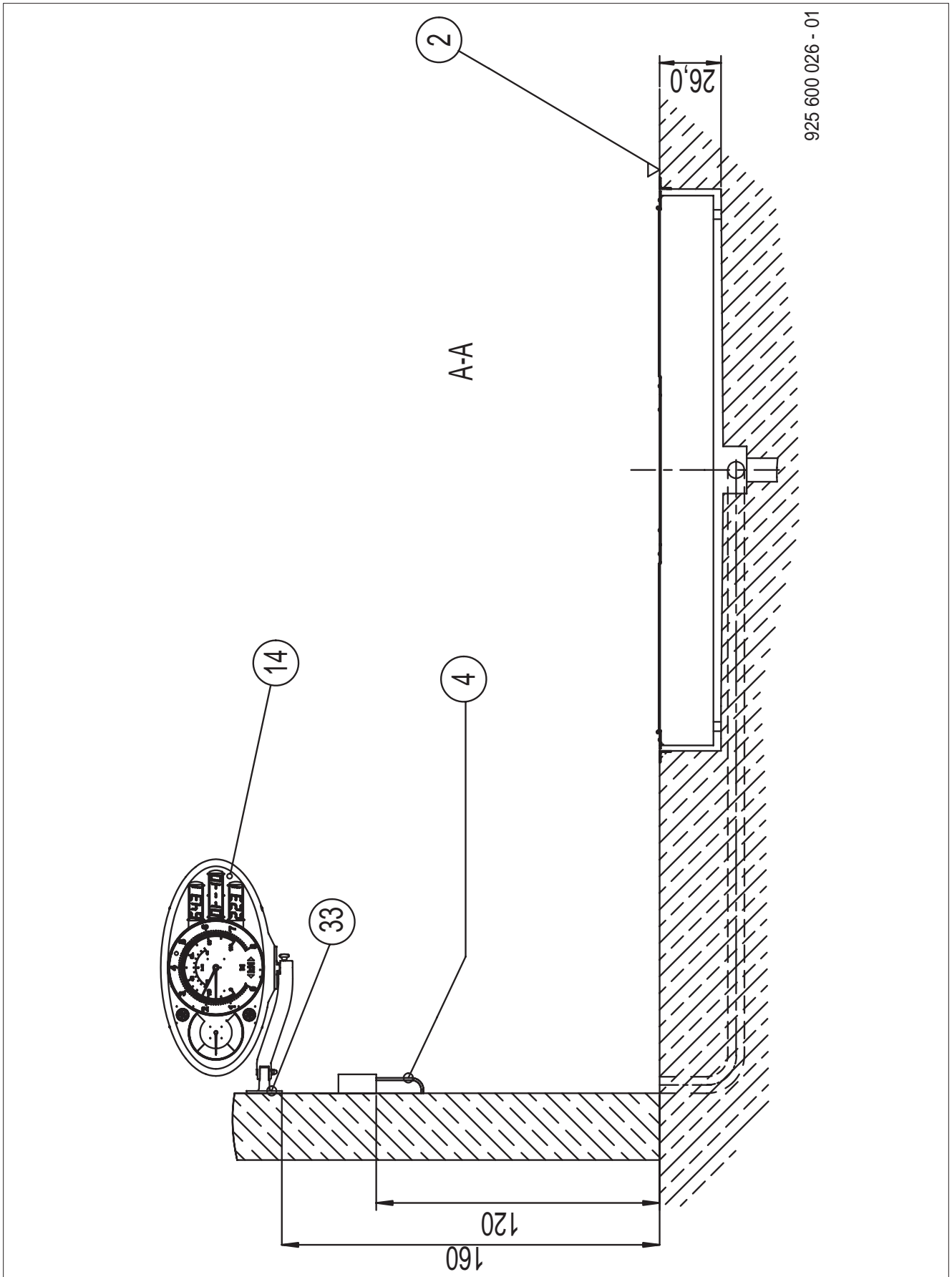

Fig. 8: Installation plan BD 6xx with wall bracket - Sectional view A-A
Item references see chapter 2

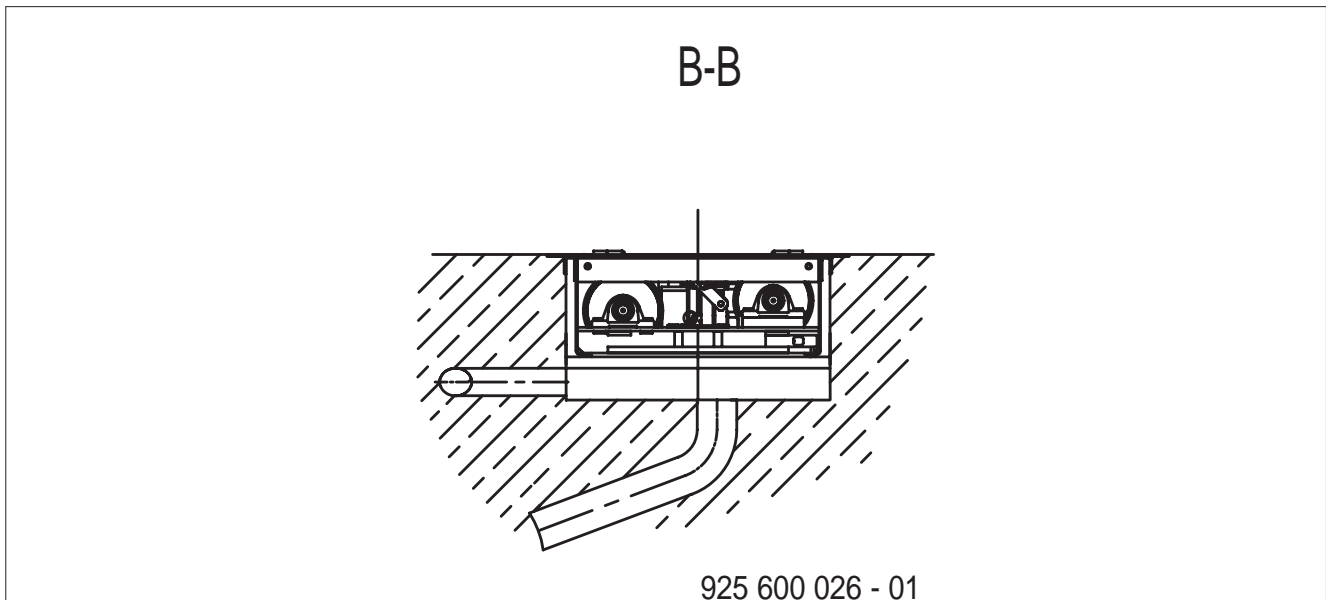

Fig. 9: Installation plan BD 6xx with wall bracket - Sectional view B-B
Item references see chapter 2

3.2 BD 6xx with column

3.2.1 Plan of pit

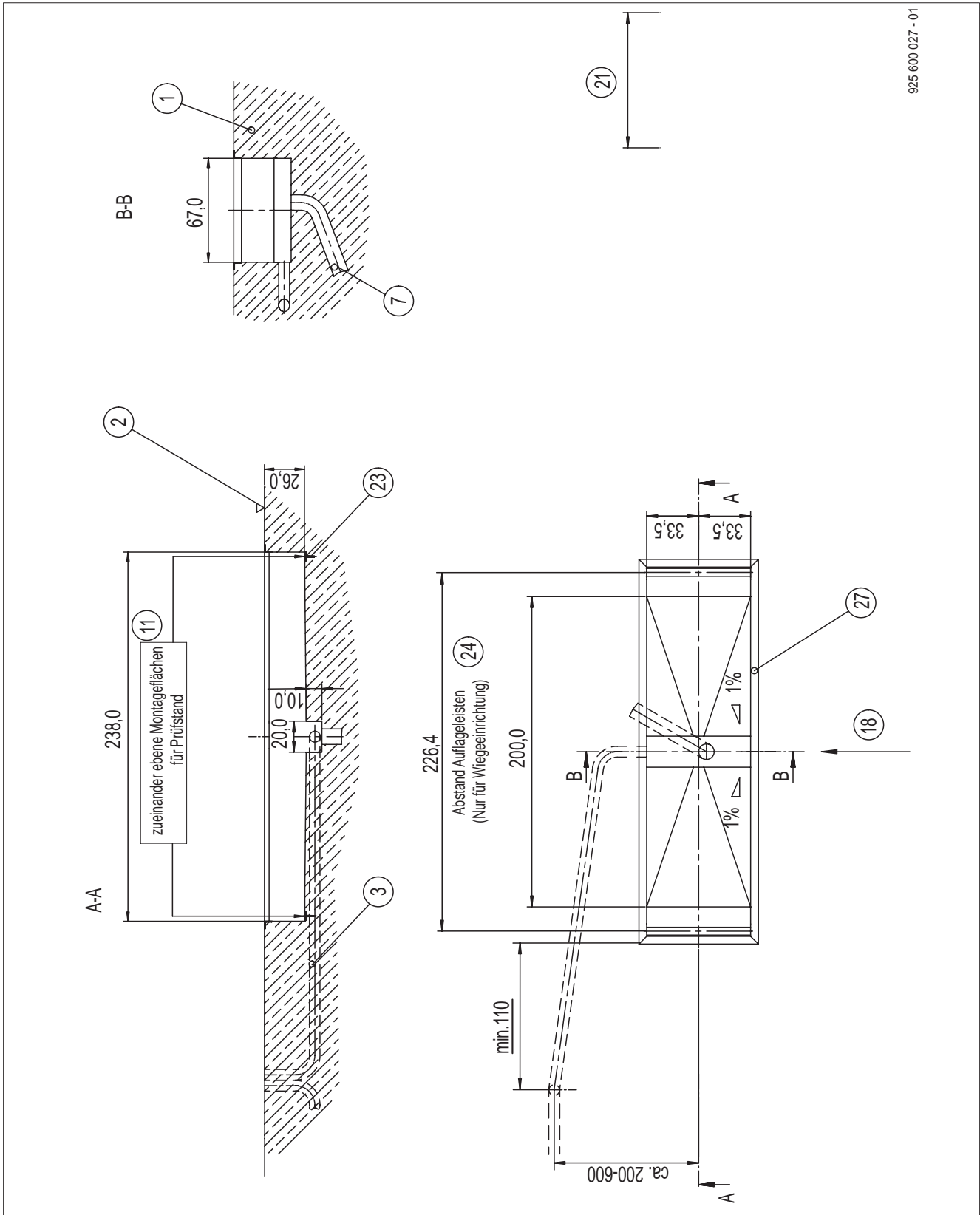

Fig. 10: Plan of pit BD 6xx with column- Overview
Item references see chapter 2

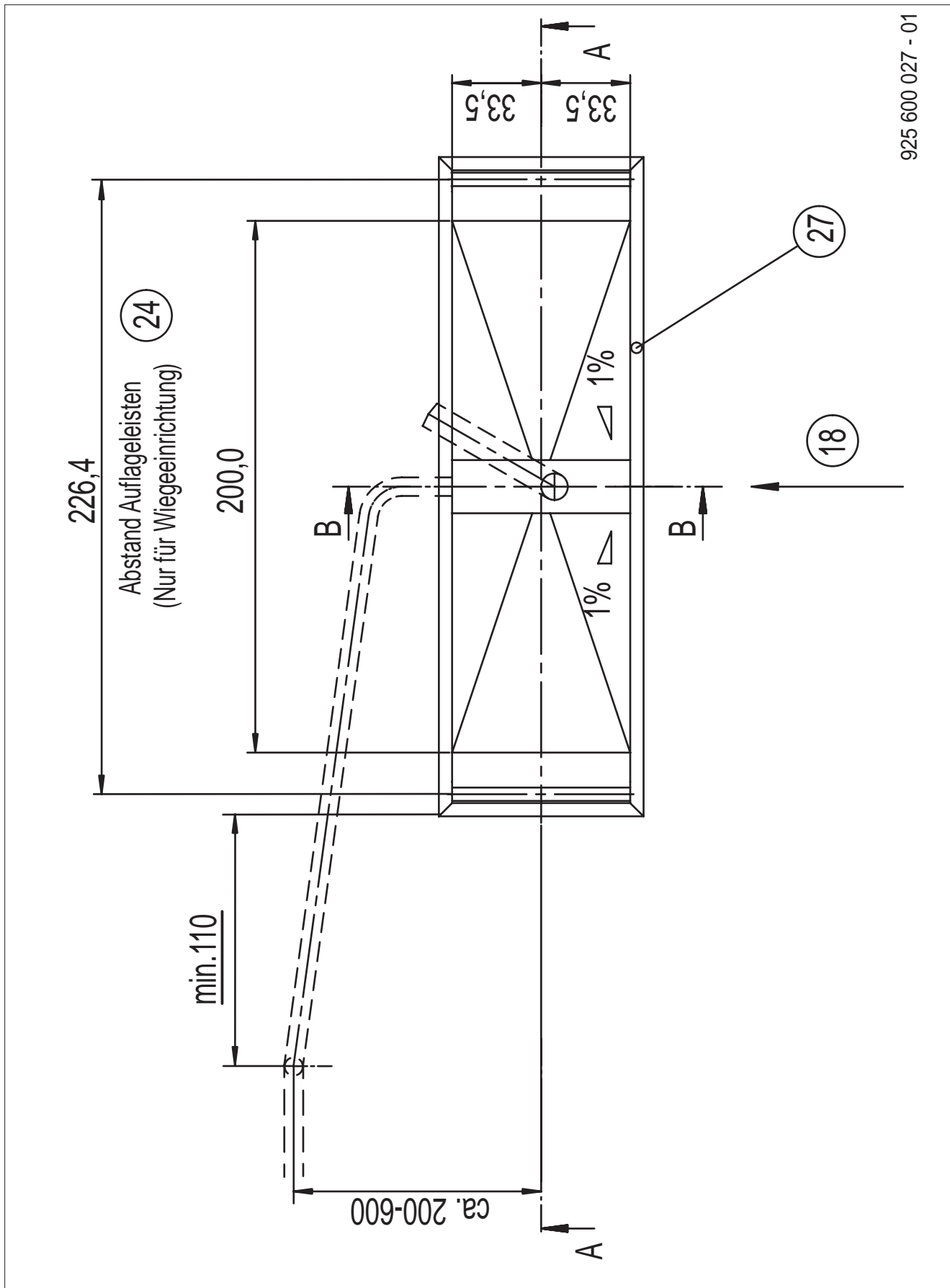
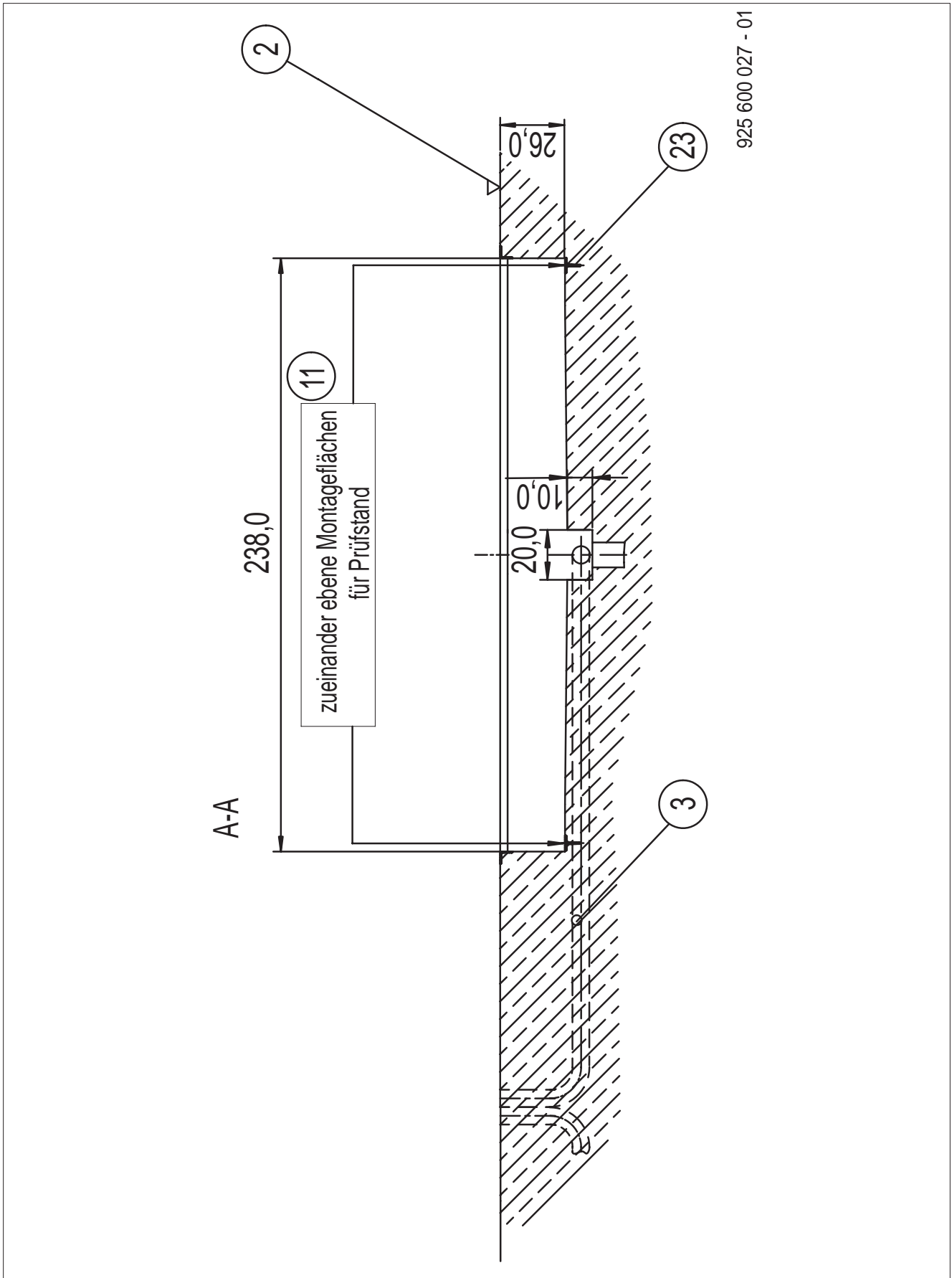

Fig. 11: Plan of pit BD 6xx with column- Ground view
Item references see chapter 2



925 600 027 - 01

Fig. 12: Plan of pit BD 6xx with column - Sectional view A-A
Item references see chapter 2

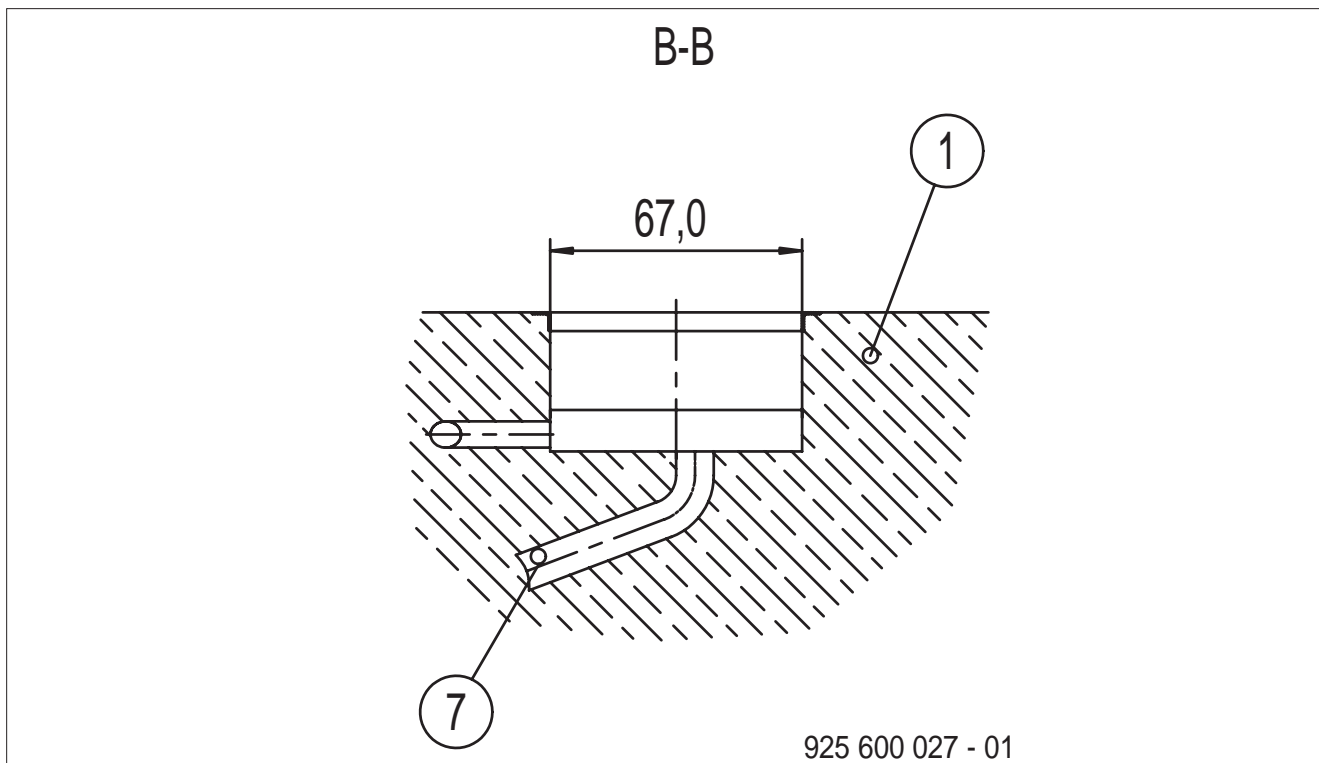

Fig. 13: Plan of pit BD 6xx with column - Sectional view B-B
Item references see chapter 2

3.2.2 Installation plan

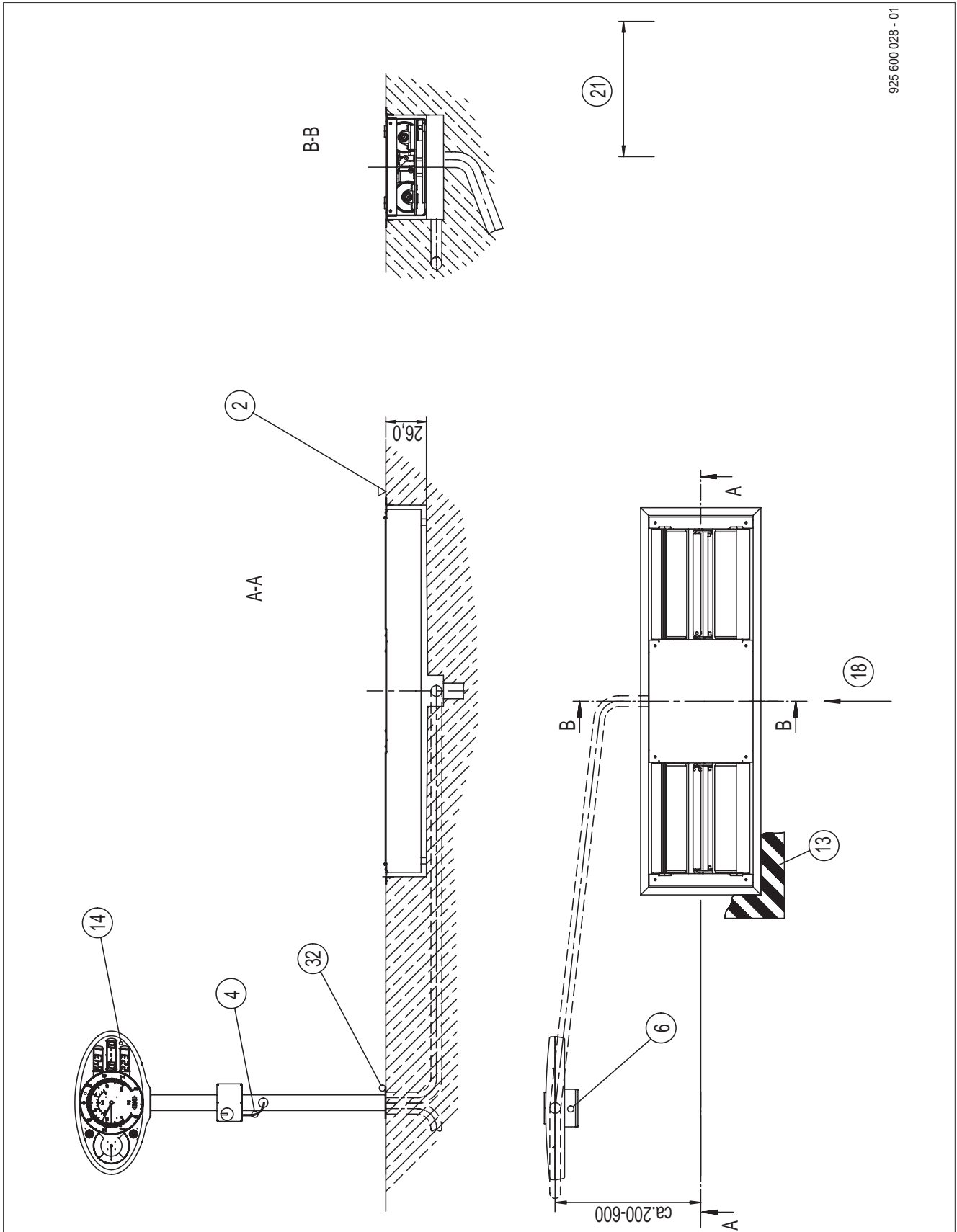
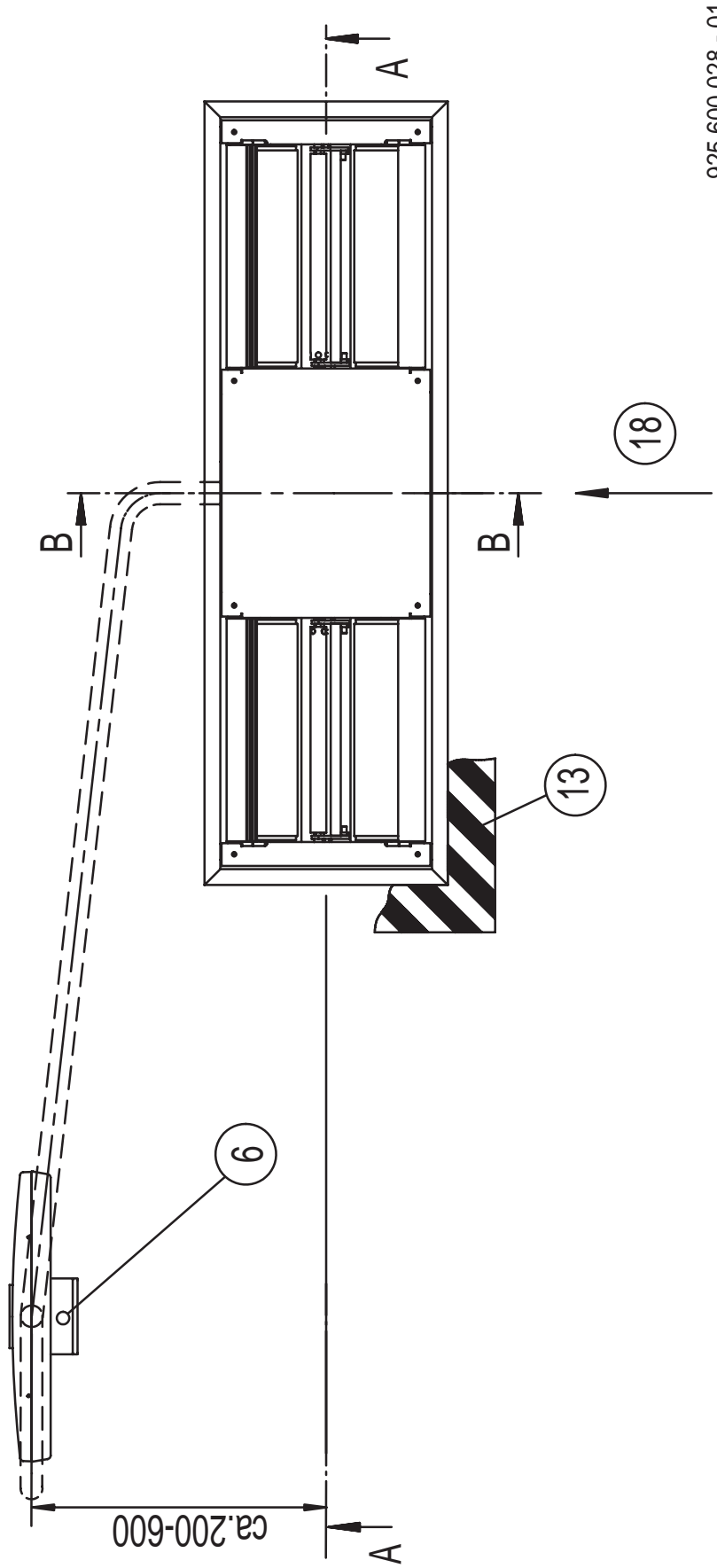

Fig. 14: Installation plan BD 6xx with column - Overview
Item references see chapter 2



925 600 028 - 01

Fig. 15: Installation plan BD 6xx with column - Ground plan
Item references see chapter 2

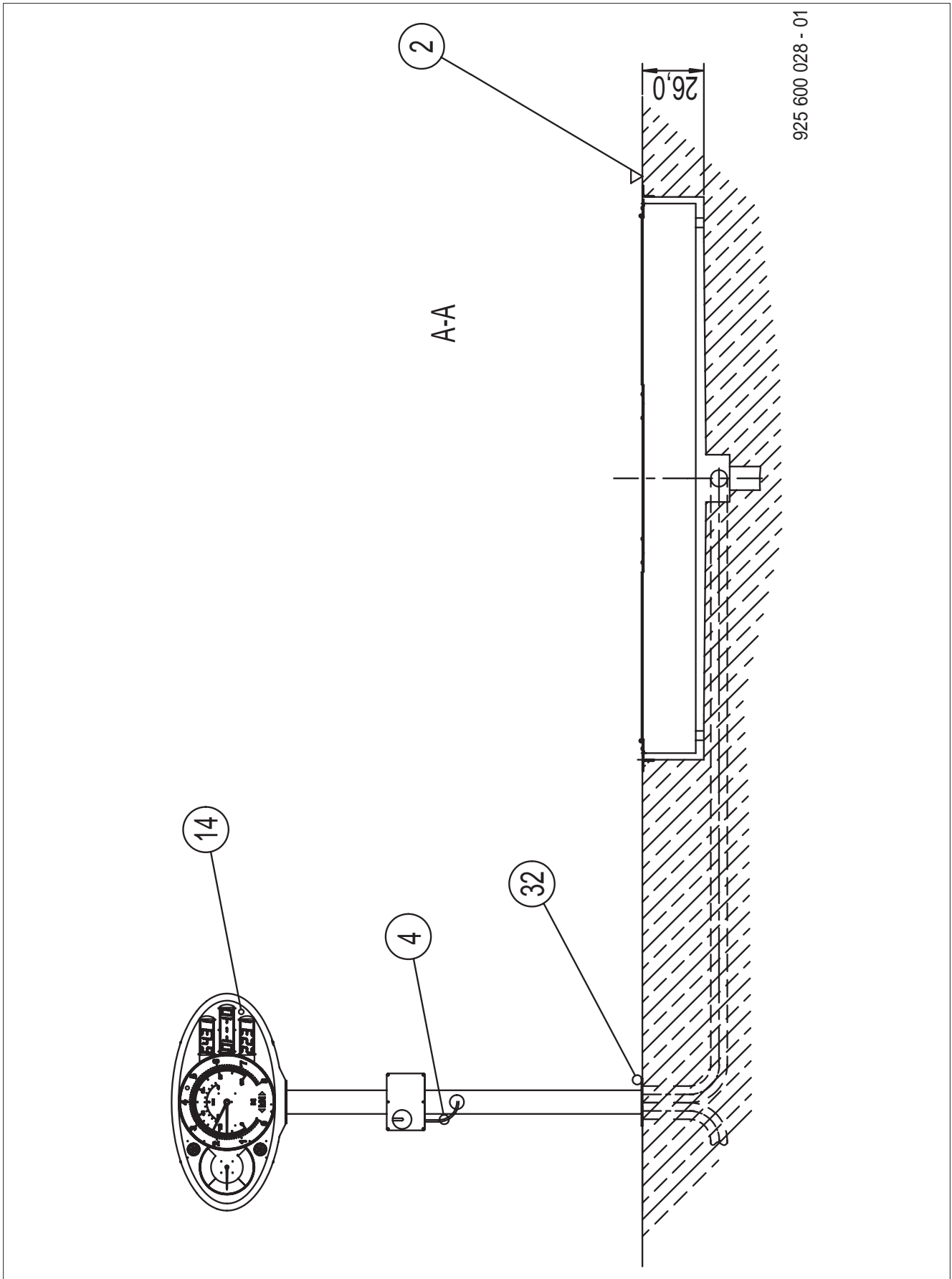

Fig. 16: Installation plan BD 6xx with column - Sectional view A-A
Item references see chapter 2

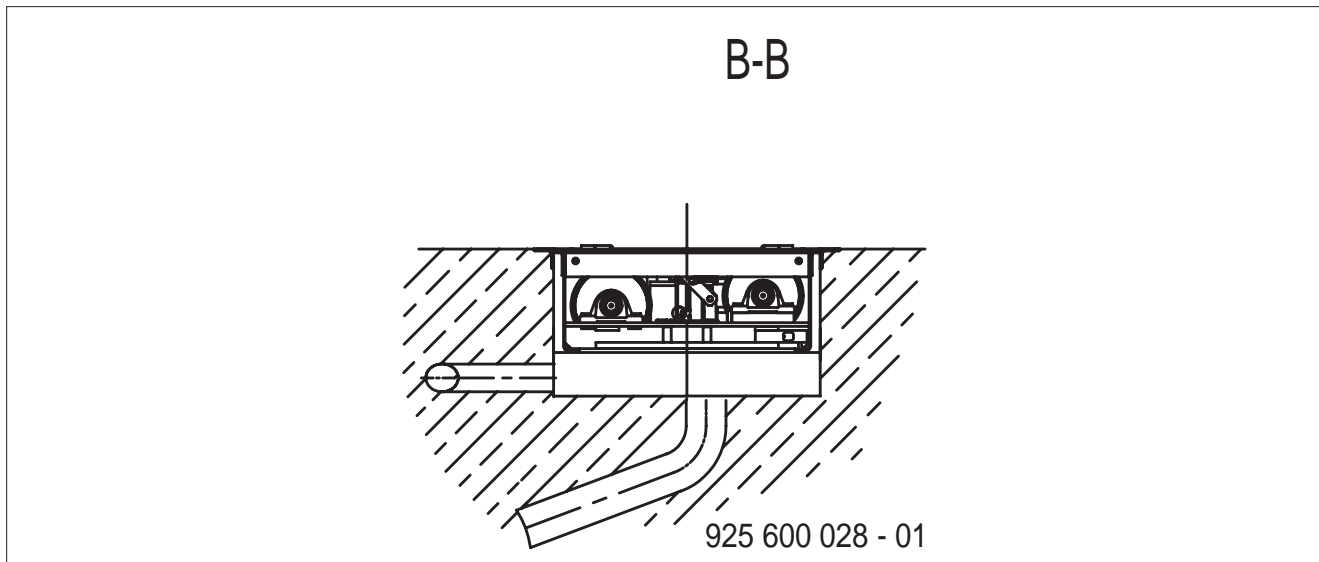
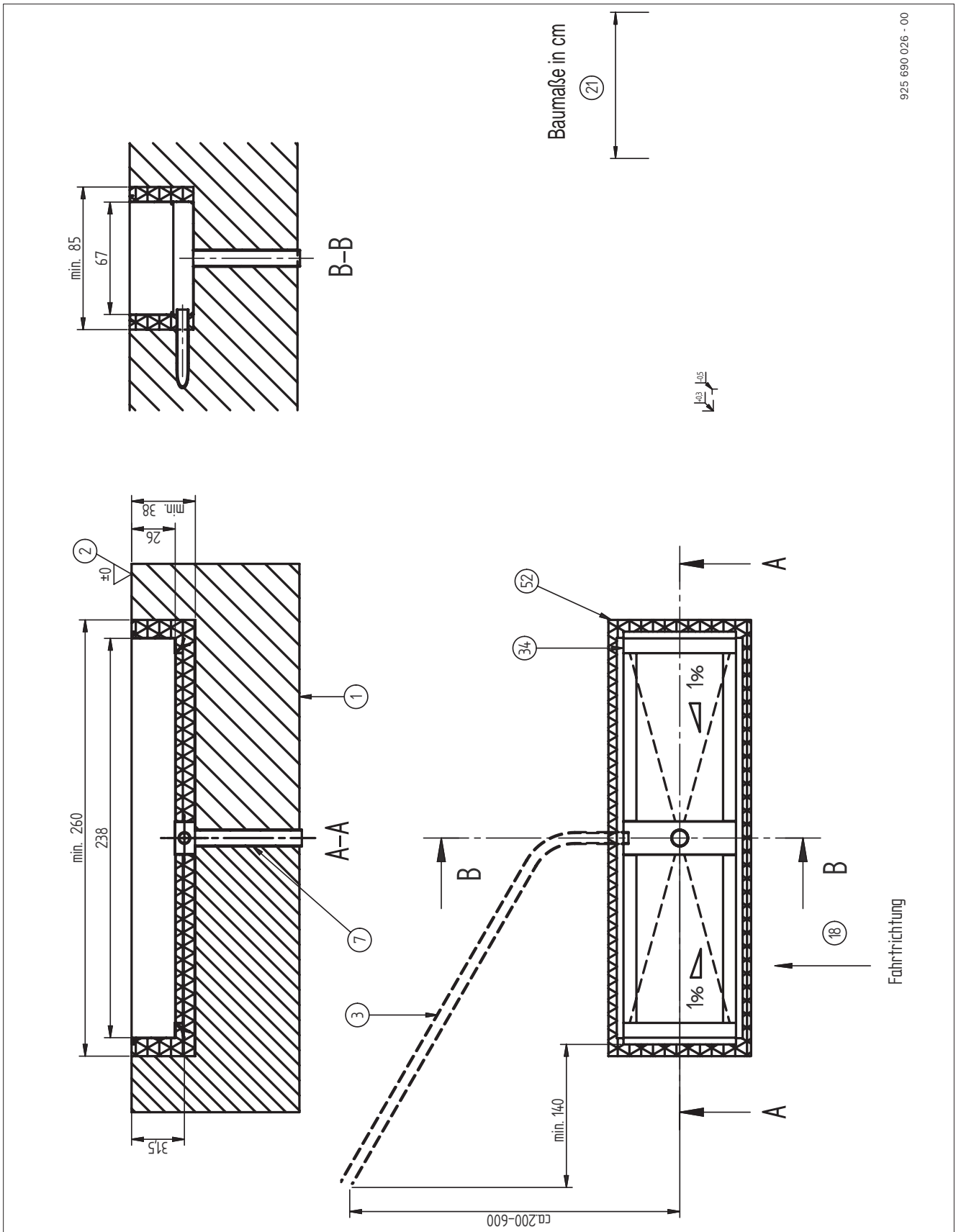

Fig. 17: Installation plan BD 6xx with column - Sectional view B-B
Item references see chapter 2

3.3 BD 6xx with assembling case



925 690 026 - 00

Fig. 18: Plan of pit BD 6xx with assembling case - Overview
Item references see chapter 2

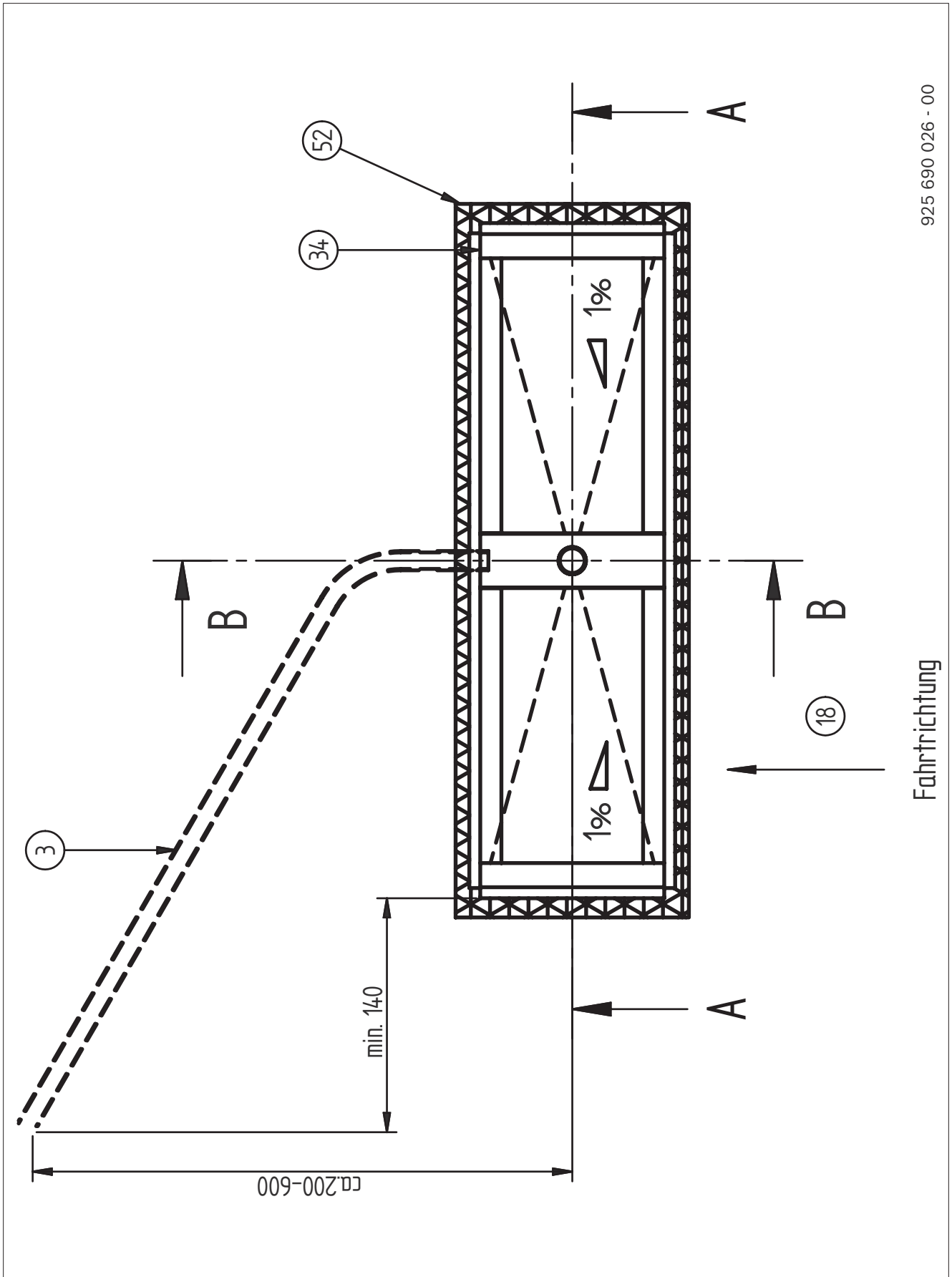

925 690 026 - 00

Fahrtrichtung

Fig. 19: Plan of pit BD 6xx with assembling case - Ground view
Item references see chapter 2

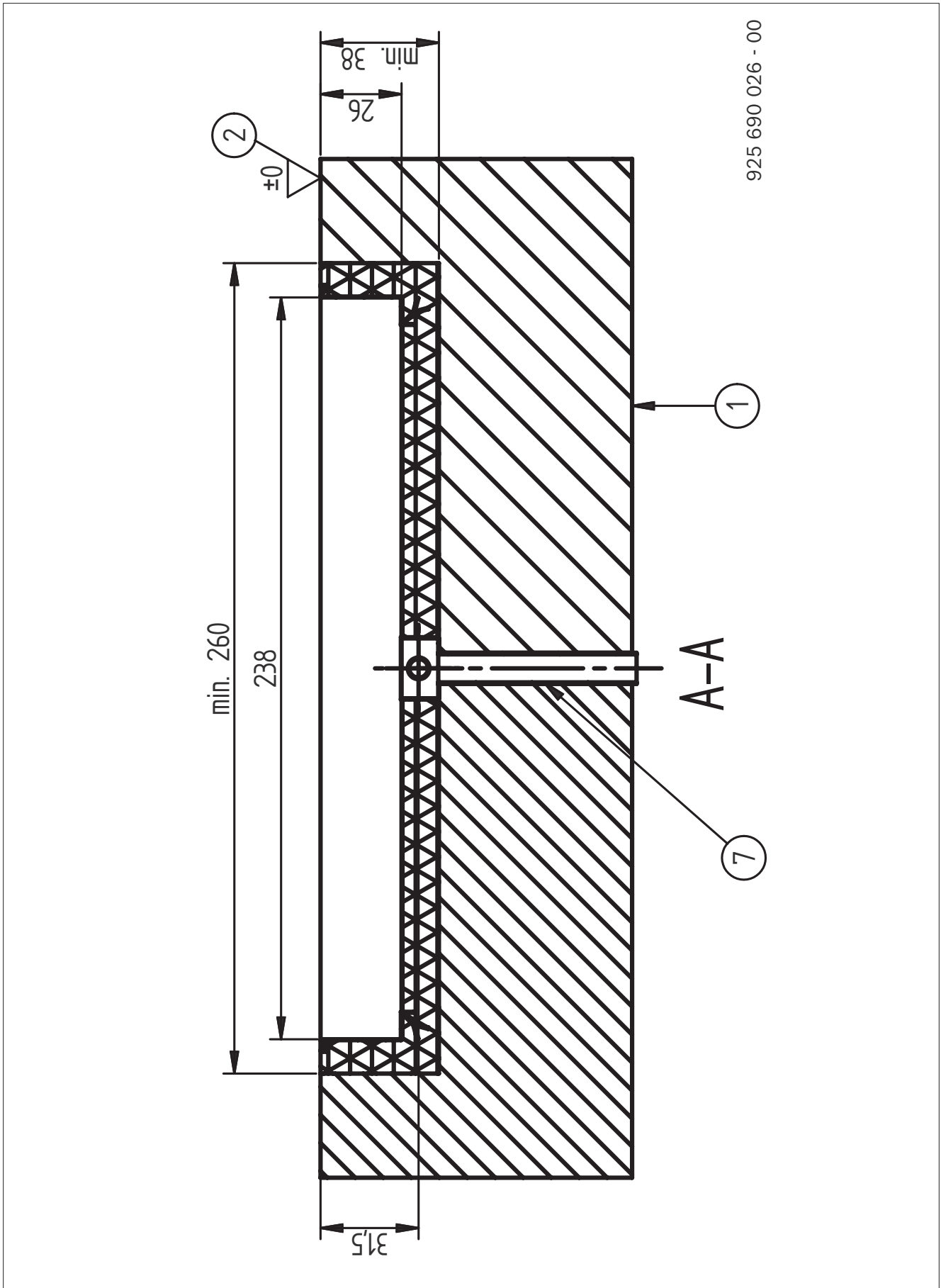

925 690 026 - 00

Fig. 20: Plan of pit BD 6xx with assembling case - Sectional view A-A
Item references see chapter 2

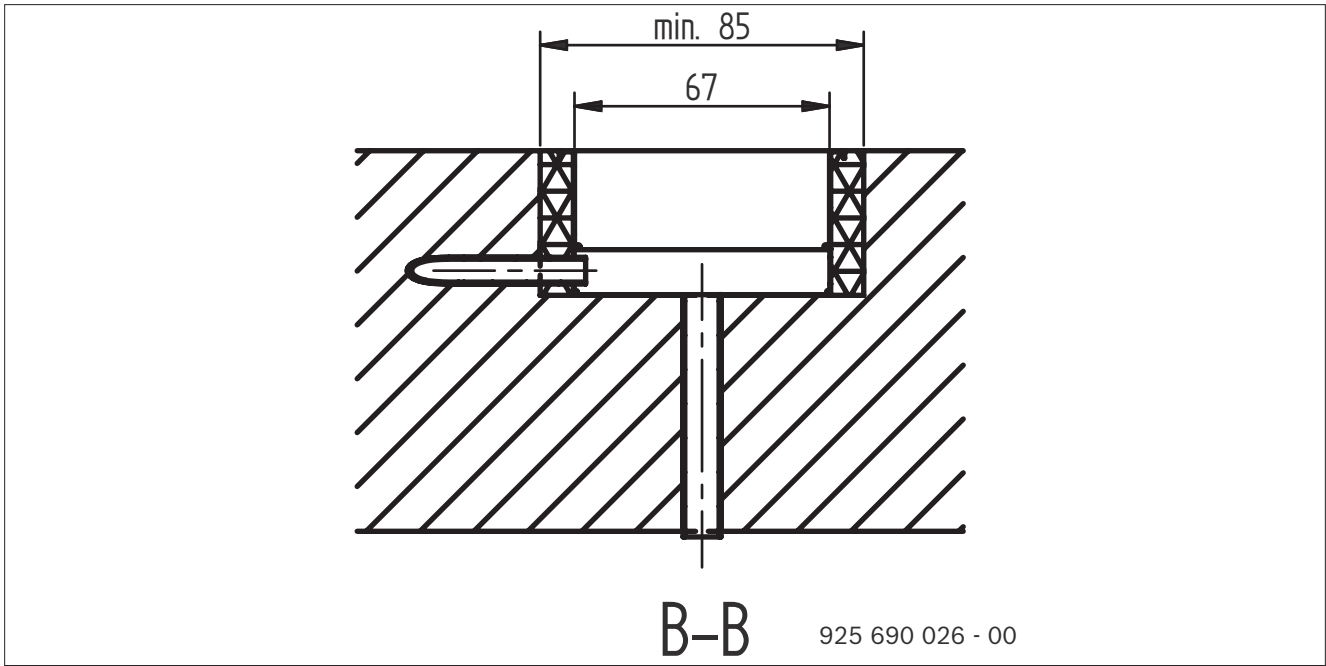

Fig. 24: Plan of pit BD 6xx with assembling case - Sectional view B-B
Item references see chapter 2

4. Load diagram

Calculated load per dowel:

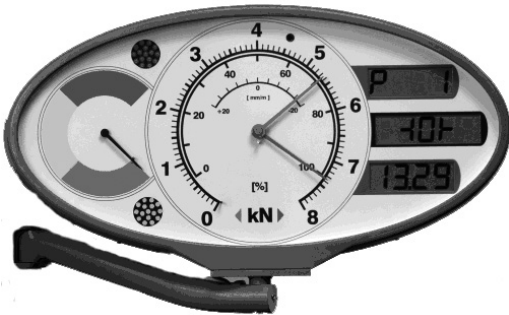

Fig. 21: Analogue display

Net weight	= 200 N
External load	= 200 N
Arm lever l ₁	= 531 mm
Bracket lever l ₂	= 133 mm

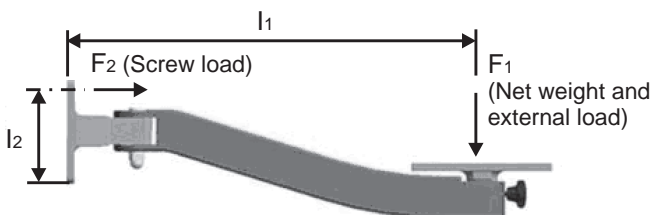

Fig. 22: Load diagram

Max. tensile force F₂ in a screw:

$$F_2 = \frac{F_1 \times l_1}{l_2} = \frac{(200\text{ N} + 200\text{ N}) \times 531\text{ mm}}{2 \times 133\text{ mm}} = \underline{\underline{800\text{ N}}}$$

Fig. 23: Calculation of the max. tensile force

Four suitable wall plugs with M10 screws are to be provided by the sutomer for the above loads. The condition of the wall must be taken into consideration.

Examples of plugs in concrete wall B15: Fischer S12

- Fischer S12
- Fischer Automatic Stahldübel FA 10/15-1
- Hilti Hülseanker HLC 10x40
- Hilti Kompaktdübel HKD M10 or equivalent

! If you have any doubt about the fastening, please contact the well-know dowel manufacturers or their agents.

! If the texture of material of the wall does not allow it to be plugged perfectly, column 935 602 134 is to be used instead of the wall bracket.

5. Auxiliary equipment

5.1 Edge Protection



Fig. 25: Edge Protection

Order number: 935 604 008
Main dimensions incl. armouring: approx. 2700 x 900 x 120 mm

5.2 Support



Fig. 26: 1 Set Support (2 pieces)

Order number: 935 603 109
Main dimensions incl. armouring: approx. 670 x 200 x 120 mm

5.3 Assembling case



Fig. 27: Assembling case (EDP)

Order number: 935 604 179
Main dimensions incl. armouring: approx. 750 x 2460 x 350 mm

Ihr Händler vor Ort:
Local distributor:

Beissbarth GmbH
Ein Unternehmen der Bosch-Gruppe
A Bosch Group Company
Hanauer Straße 101
80993 München (Munich, Bavaria)
GERMANY

Tel. +49-89-149 01-0
Fax +49-89-149 01-285/-240

www.beissbarth.com
sales@beissbarth.com

905 607 041 | 2009-07-29 |

