



7522-M001-15_R

**G9256.11SL - G9256.11ST
G9256.15 - G9256T.15 - G9256A.15
G9256D.15 - G9256TD.15
G9256.15SL
G10360.15 - G10360T.15 - G10360A.15
G10360D.15 - G10360TD.15**

INSTRUCTION MANUAL

GB

TRANSLATION FROM THE
ORIGINAL INSTRUCTIONS

For spare parts drawings refer to the section "LIST OF COMPONENTS" enclosed to this manual.

- For any further information please contact your local dealer or call:

Technical services: **RAVAGLIOLI S.p.A.** - Via 1° Maggio, 3 - 40037 Pontecchio Marconi - Bologna Italy
Phone (+39) 051 6781511 - Telex 510697 RAV I - Fax (+39) 051 846349 - e-mail: aftersales@ravaglioli.com

7522-M001-15_R - Rev. n. 15 (03/2018)



SUMMARY

SYMBOLS USED IN THE MANUAL AND ON THE MACHINE _____	11	12.4 Wheel clamping _____	23
1.0 GENERAL INTRODUCTION _____	13	12.5 Functioning of tool holder arm _____	25
1.1 <i>Introduction</i> _____	13	12.5.1 <i>Tools rotation</i> _____	26
2.0 INTENDED USE _____	13	12.5.2 <i>Tools unit extraction/insertion</i> _____	26
2.1 <i>Training of personnel</i> _____	14	12.5.3 <i>Quick-fit device (G9256.11SL, G9256.11ST and G9256.15SL)</i> _____	26
3.0 SAFETY DEVICES _____	14	12.6 Tubeless tyres _____	27
3.1 <i>Residual risks</i> _____	15	12.6.1 <i>Bead breaking</i> _____	27
4.0 GENERAL SAFETY RULES _____	15	12.6.2 <i>Demounting</i> _____	29
5.0 PACKING AND MOBILIZATION FOR TRANSPORT _____	16	12.6.3 <i>Mounting</i> _____	31
6.0 UNPACKING _____	16	12.7 Tyres with inner tube _____	33
7.0 MOBILIZATION _____	16	12.7.1 <i>Bead breaking</i> _____	33
8.0 WORKING ENVIRONMENT CONDITIONS _____	17	12.7.2 <i>Demounting</i> _____	34
8.1 <i>Working position</i> _____	17	12.7.3 <i>Mounting</i> _____	35
8.2 <i>Installation space</i> _____	17	12.8 Wheels with bead wire _____	37
8.3 <i>Lighting</i> _____	17	12.8.1 <i>Beading and demounting</i> _____	37
9.0 MACHINE ASSEMBLY _____	17	12.8.2 <i>Mounting</i> _____	38
9.1 <i>Anchoring system</i> _____	17	13.0 ROUTINE MAINTENANCE _____	39
9.2 <i>Fixtures contained in the packing</i> _____	18	14.0 TROUBLESHOOTING TABLE _____	42
10.0 ELECTRICAL CONNECTIONS _____	18	15.0 TECHNICAL DATA _____	44
10.1 <i>Oil check on oil-pressure power unit</i> _____	18	15.1 <i>G9256.11SL technical data</i> _____	44
10.2 <i>Check of motor rotation direction</i> _____	19	15.2 <i>G9256.11ST technical data</i> _____	44
10.3 <i>Electrical checks</i> _____	19	15.3 <i>Technical data G9256.15 - G9256T.15</i> _____	44
11.0 CONTROLS _____	20	15.4 <i>G9256A.15 technical data</i> _____	44
11.1 <i>Cable control device</i> _____	20	15.5 <i>Technical data G9256D.15 - G9256TD.15</i> _____	44
11.2 <i>Control device with bluetooth transmission (optional)</i> _____	21	15.6 <i>G9256.15SL technical data</i> _____	45
11.3 <i>Handle control in air (standard for G9256A.15 - G10360A.15 versions) (optional for G9256.11SL (VARGNAV43AD - VARGNAV43ASL) - G9256.15SL (VARGNAV43AD - VARGNAV43ASL) - G9256.15 and G9256T.15 (VARGNAV43A) - G10360.15 and G10360T.15 (VARGNAV63A.15) - G10360D.15 and G10360TD.15 (VARGNAV63AD))</i> _____	22	15.7 <i>Technical data G10360.15 - G10360T.15</i> _____	45
12.0 USING THE MACHINE _____	23	15.8 <i>G10360A.15 technical data</i> _____	45
12.1 <i>Precaution measures during tyre removal and fitting</i> _____	23	15.9 <i>Technical data G10360D.15 - G10360TD.15</i> _____	45
12.2 <i>Preliminary operations</i> _____	23	15.10 <i>Dimensions</i> _____	46
12.3 <i>Preparing the wheel</i> _____	23	16.0 STORING _____	53
		17.0 SCRAPPING _____	53
		18.0 REGISTRATION PLATE DATA _____	53
		19.0 FUNCTIONAL DIAGRAMS _____	53
		Table A - <i>Electric diagram (G9256.11SL - G9256.15SL)</i> _____	54
		Table B - <i>Electric diagram (G9256.11ST)</i> _____	63
		Table C - <i>Electric diagram (G9256.15 - G9256T.15 - G10360.15 - G10360T.15)</i> _____	72
		Table D - <i>Electric diagram (G9256A.15 - G10360A.15) (VARGNAV43A) (VARGNAV63A)</i> _____	76



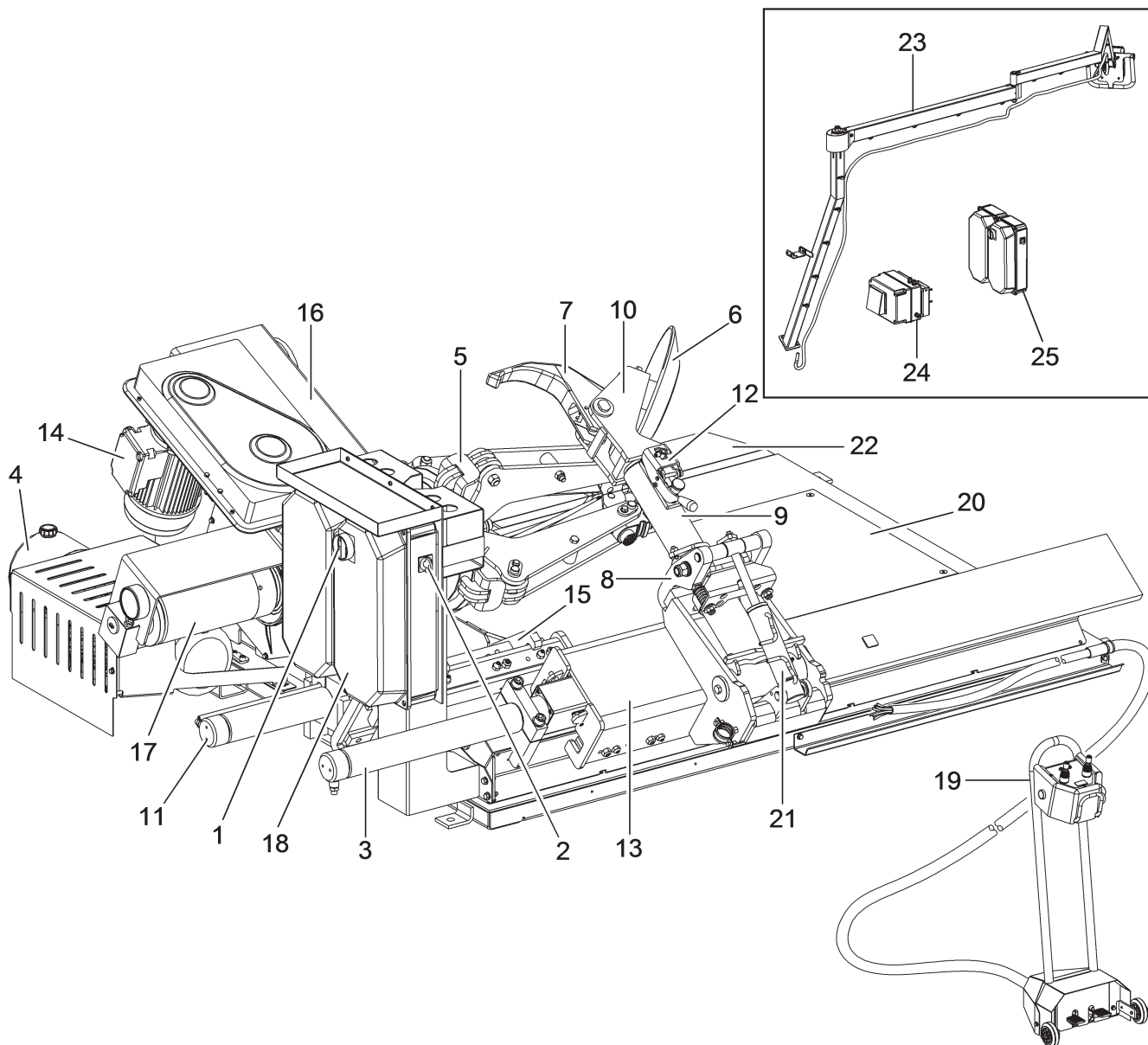
Table E - Electric diagram (G9256D.15 - G9256TD.15 - G10360D.15 - G10360TD.15) _____	79
Table F - Electric diagram (G9256.11SL - G9256.15SL) (VARGNAV43AD) _____	83
Table G - Electric diagram (G9256.15SL) (Inverter version) _____	93
Table H - Electric diagram (G9256.11SL - G9256.15SL (VARGNAV43ASL)) _____	112
Table I - Electric diagram (G9256.15 - G9256T.15 - G10360.15 - G10360T.15 (VARGNAVBT)) _____	121
Table I - Electric diagram (G9256.11SL - G9256.15SL (VARGNAV43AD)) (G9256D.15 - G9256TD.15 - G10360D.15 - G10360TD.15 (VARGNAVDBT)) _____	138

Table M - Electric diagram (G10360D.15 - G10360TD.15 (VARGNAV63AD)) _____	156
Table N - Oil-pressure diagram (G9256.11SL - G9256.15SL) _____	165
Table O - Oil-pressure diagram (G9256.11ST) _____	166
Table P - Oil-pressure diagram (G9256.15 - G9256T.15 - G9256A.15 - G9256D.15 - G9256TD.15) _____	167
Table Q - Oil-pressure diagram (G10360.15 - G10360T.15 - G10360A.15 - G10360D.15 - G10360TD.15) _____	168

20.0 LIST OF COMPONENTS

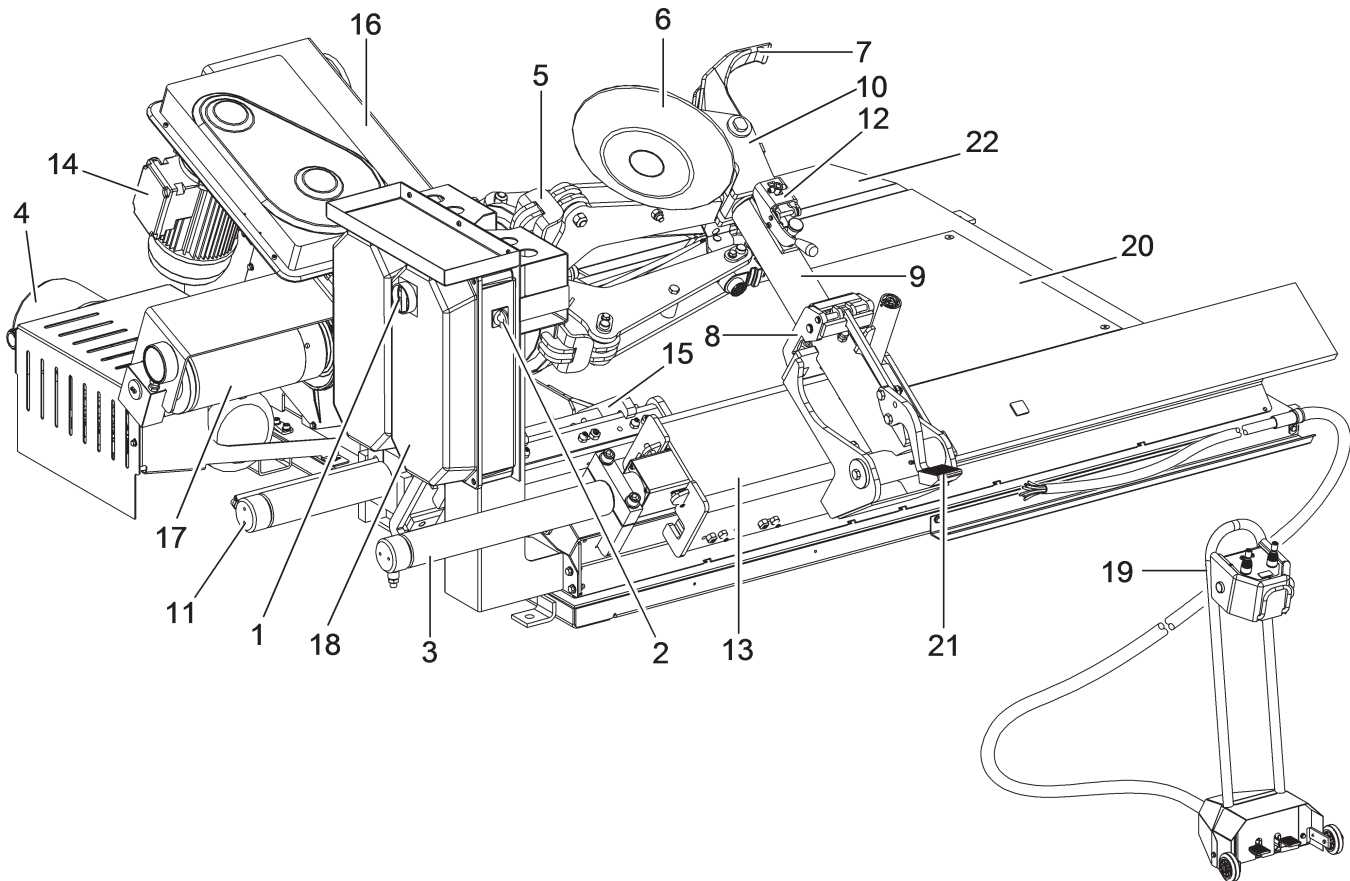


FIG. 1 - G9256.11SL



KEY

- | | |
|--|--|
| 1 - Main switch | 16 - Mandrel arm |
| 2 - Selector 1-0-2 self-centring chuck speed control | 17 - Mandrel opening/closing cylinder |
| 3 - Tools carriage translation cylinder | 18 - Electric panel |
| 4 - Hydraulic power unit | 19 - Control unit |
| 5 - Self-centring chuck | 20 - Platform |
| 6 - Bead breaking disc | 21 - Tools holder arm unlock cylinder |
| 7 - Tool | 22 - Ramp |
| 8 - Jack | 23 - Handle control in air (aerial handle control version - VARGNAV43ASL) (inverter version - VARGNAV43AD) |
| 9 - Tool holder arm | 24 - Inverter (inverter version - VARGNAV43AD) |
| 10 - Tools unit | 25 - Electric panel (aerial handle control version - VARGNAV43ASL) (inverter version - VARGNAV43AD) |
| 11 - Mandrel carriage translation cylinder | |
| 12 - Quick fit tool | |
| 13 - Tools carriage | |
| 14 - Mandrel rotation motor | |
| 15 - Mandrel carriage | |

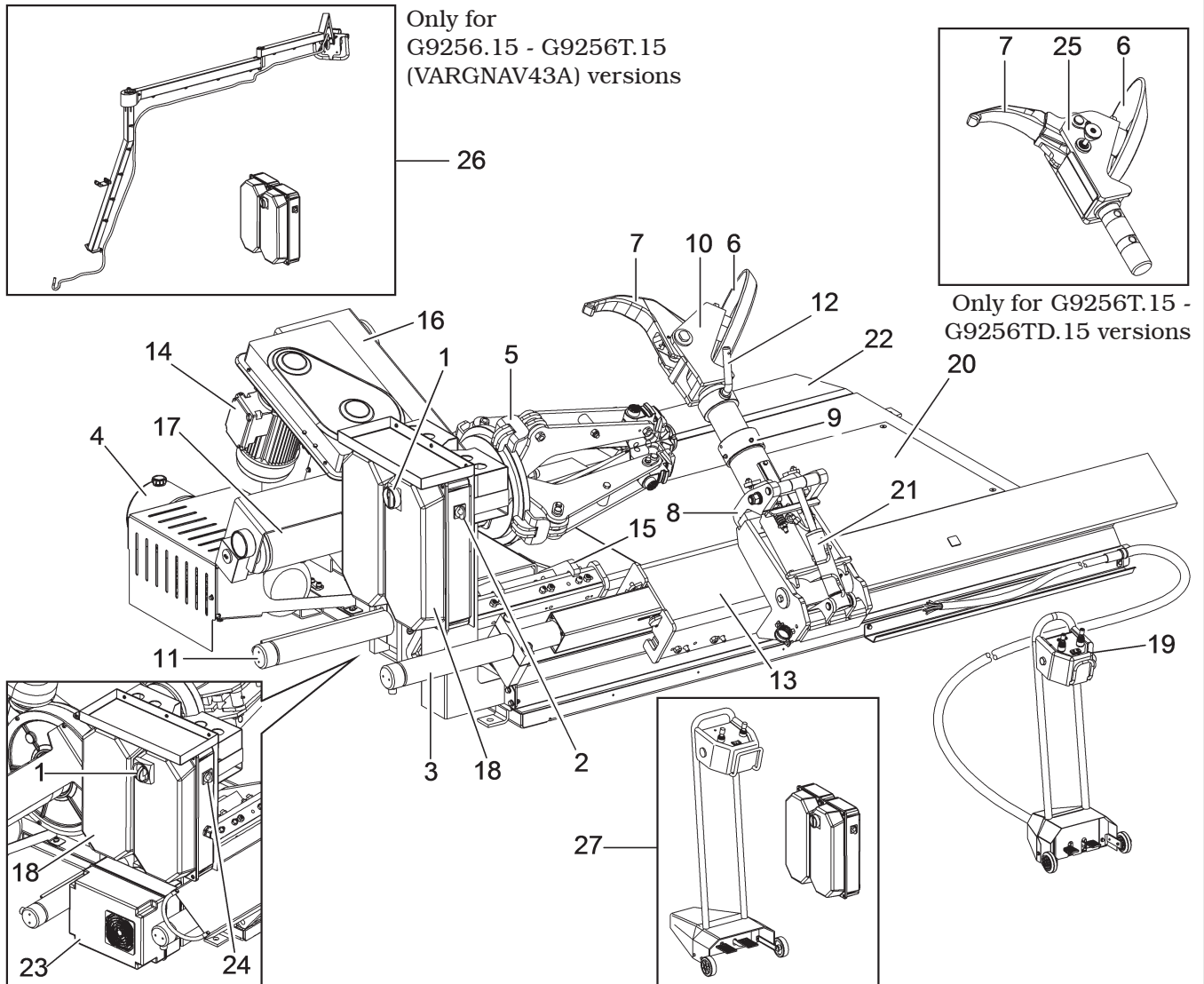
FIG. 2 - G9256.11ST

KEY

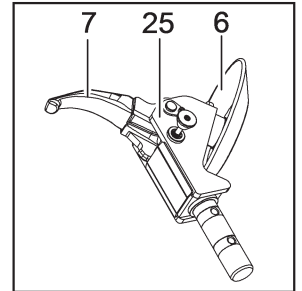
- | | |
|--|---------------------------------------|
| 1 - Main switch | 12 - Quick fit tool |
| 2 - Selector 1-0-2 self-centring chuck speed control | 13 - Tools carriage |
| 3 - Tools carriage translation cylinder | 14 - Mandrel rotation motor |
| 4 - Hydraulic power unit | 15 - Mandrel carriage |
| 5 - Self-centring chuck | 16 - Mandrel arm |
| 6 - Bead breaking disc | 17 - Mandrel opening/closing cylinder |
| 7 - Tool | 18 - Electric panel |
| 8 - Jack | 19 - Control unit |
| 9 - Tool holder arm | 20 - Platform |
| 10 - Tools unit | 21 - Tools holder arm unlock pedal |
| 11 - Mandrel carriage translation cylinder | 22 - Ramp |



FIG. 3 - G9256.15 - G9256T.15 - G9256D.15 - G9256TD.15



Only for
G9256.15 - G9256T.15
(VARGNAV43A) versions



Only for G9256T.15 -
G9256TD.15 versions

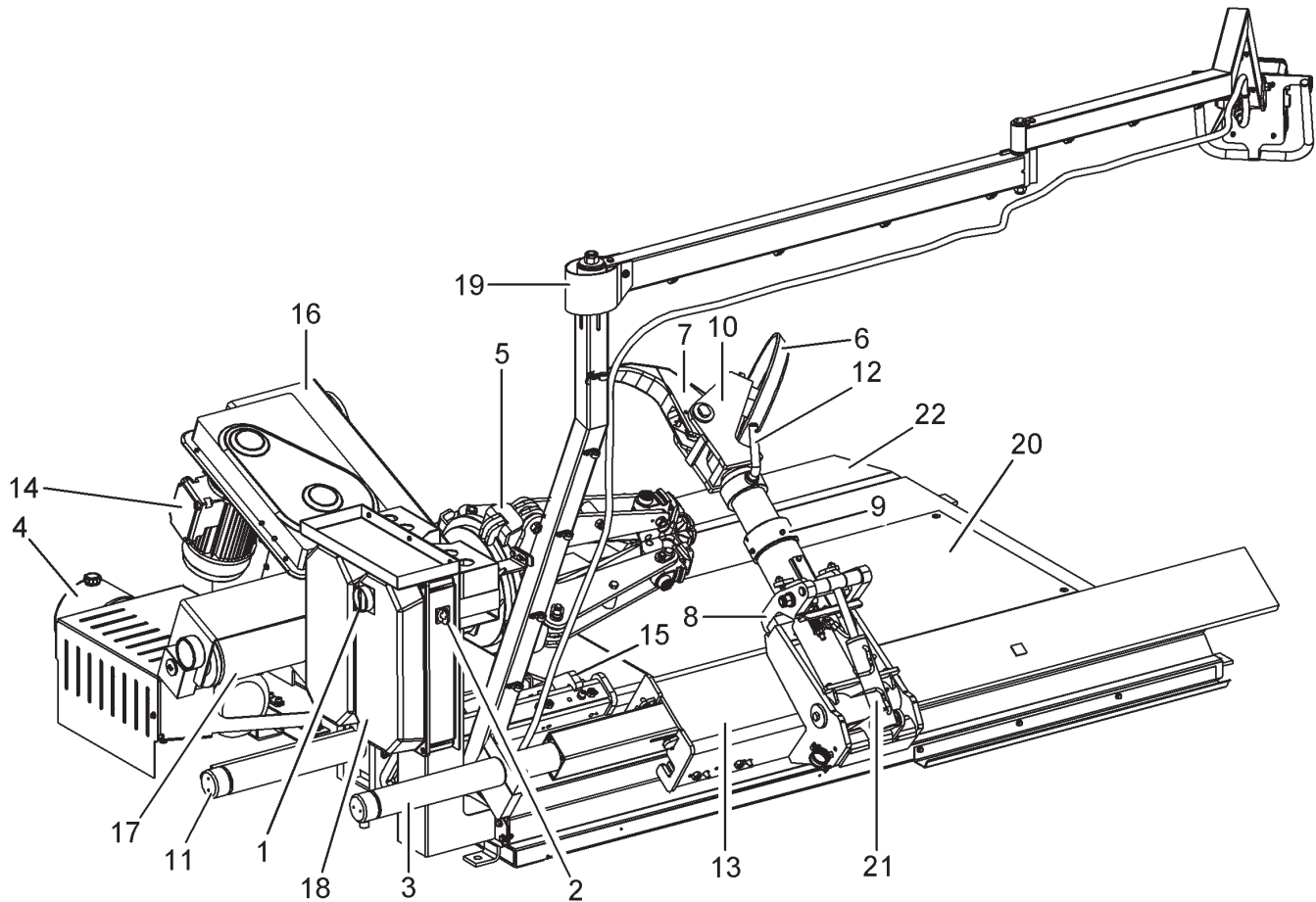
Only for G9256D.15 - G9256TD.15 versions

Only for G9256.15 - G9256T.15
(VARGNAVBTH) and G9256D.15 - G9256TD.15
(VARGNAVBTH) versions

KEY

- 1 - Main switch
- 2 - Selector 1-0-2 self-centring chuck speed control
- 3 - Tools carriage translation cylinder
- 4 - Hydraulic power unit
- 5 - Self-centring chuck
- 6 - Bead breaking disc
- 7 - Tool
- 8 - Jack
- 9 - Tool holder arm
- 10 - Tools unit
- 11 - Mandrel carriage translation cylinder
- 12 - Tool unit positioning lever
- 13 - Tools carriage
- 14 - Mandrel rotation motor
- 15 - Mandrel carriage
- 16 - Mandrel arm
- 17 - Mandrel opening/closing cylinder
- 18 - Electric panel
- 19 - Control unit
- 20 - Platform
- 21 - Tools holder arm unlock cylinder
- 22 - Ramp
- 23 - Inverter (only for G9256D.15 - G9256TD.15 versions)
- 24 - 1-2-3 Selector self-centring speed control (only for G9256D.15 - G9256TD.15 versions)
- 25 - Tool unit (only for G9256T.15 - G9256TD.15 versions)
- 26 - Handle control in air (aerial handle control version only for G9256.15 - G9256T.15 (VARGNAV43A) versions)
- 27 - Control unit (bluetooth version only for G9256.15 and G9256T.15 (VARGNAVBTH)) (bluetooth version only for G9256D.15 and G9256TD.15 (VARGNAVBTH))

FIG. 4 - G9256A.15

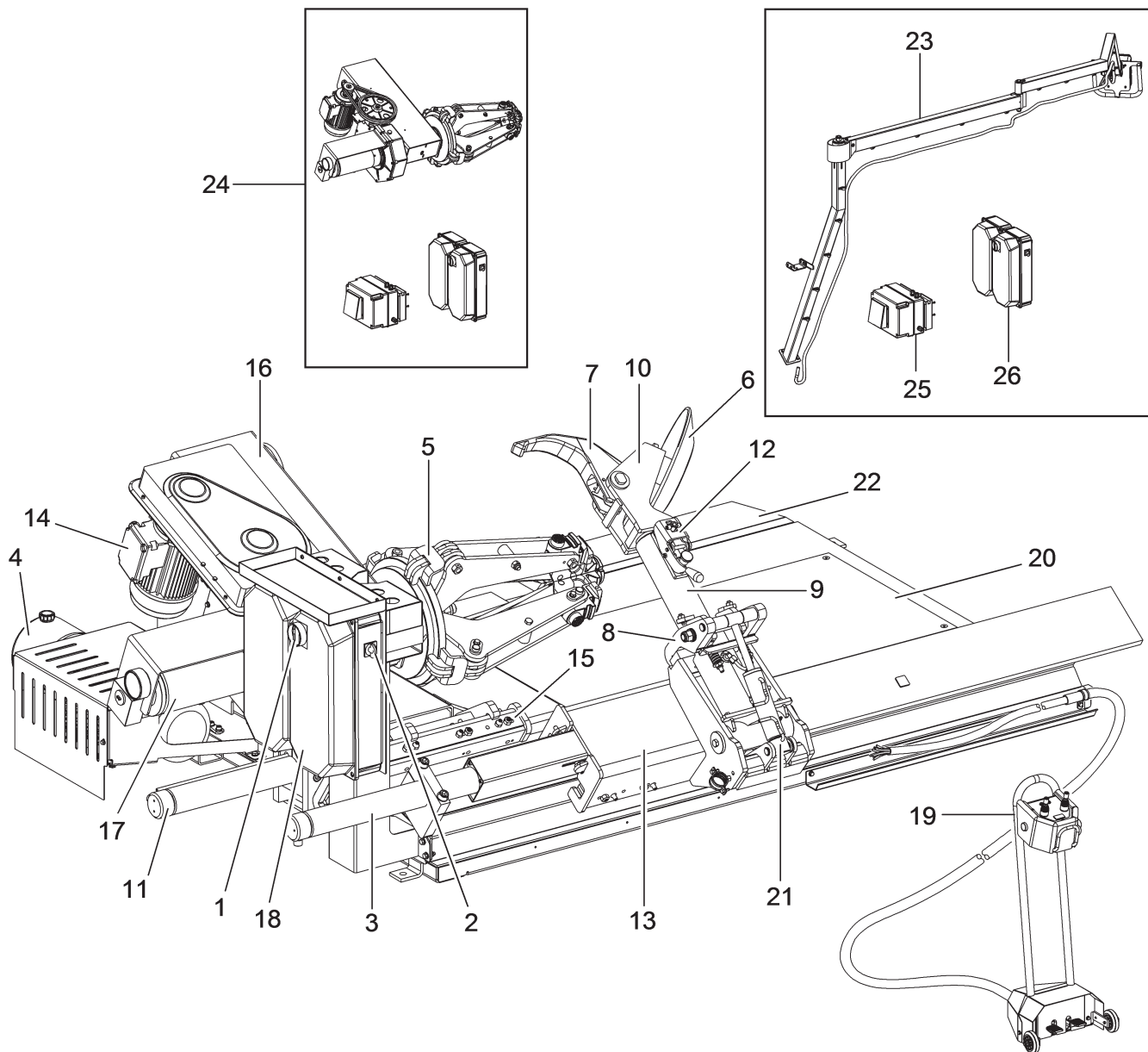


KEY

- | | |
|--|---------------------------------------|
| 1 - Main switch | 12 - Quick fit tool |
| 2 - Selector 1-0-2 self-centring chuck speed control | 13 - Tools carriage |
| 3 - Tools carriage translation cylinder | 14 - Mandrel rotation motor |
| 4 - Hydraulic power unit | 15 - Mandrel carriage |
| 5 - Self-centring chuck | 16 - Mandrel arm |
| 6 - Bead breaking disc | 17 - Mandrel opening/closing cylinder |
| 7 - Tool | 18 - Electric panel |
| 8 - Jack | 19 - Control unit |
| 9 - Tool holder arm | 20 - Platform |
| 10 - Tools unit | 21 - Tools holder arm unlock cylinder |
| 11 - Mandrel carriage translation cylinder | 22 - Ramp |

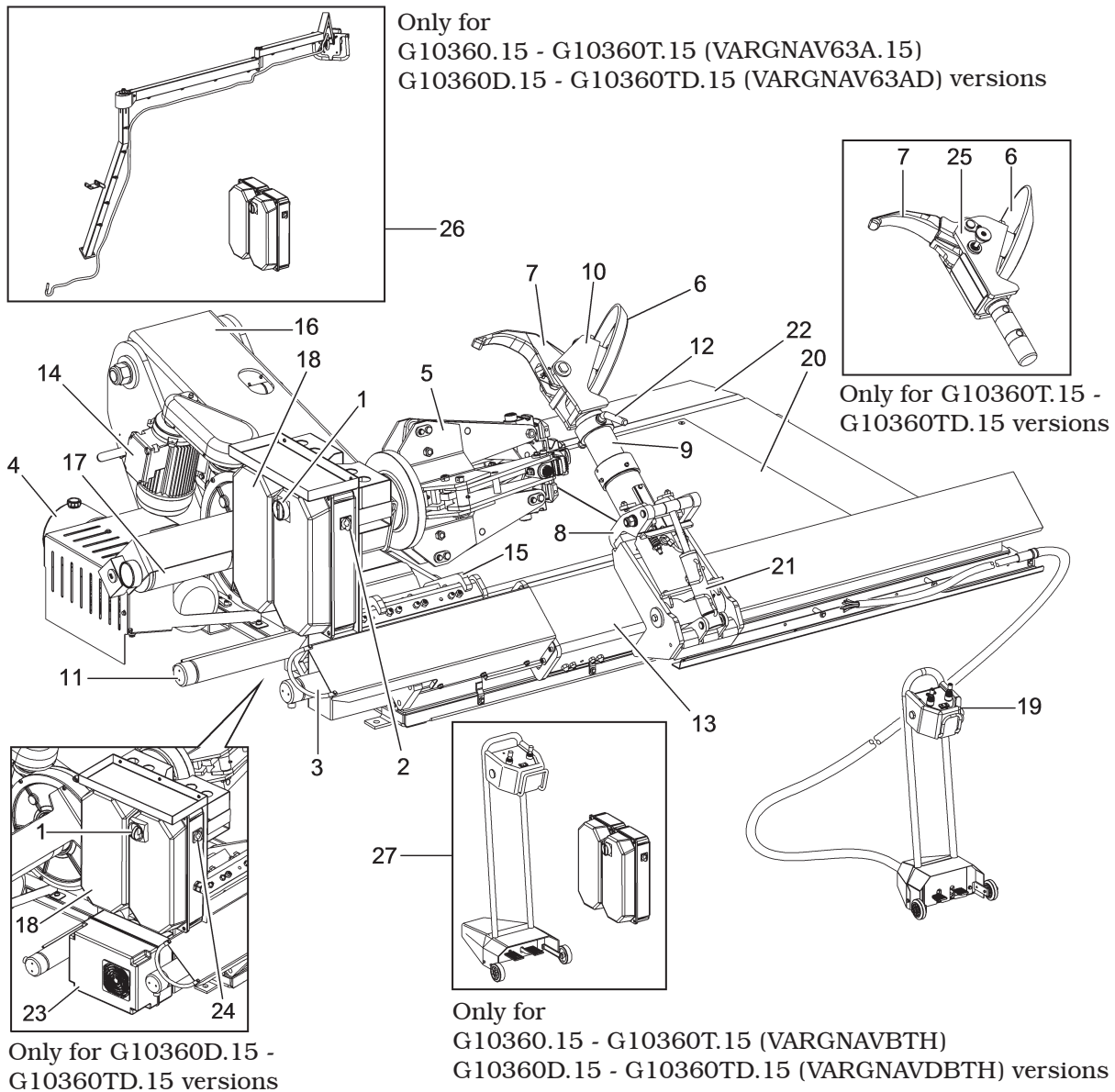


FIG. 5 - G9256.15SL



KEY

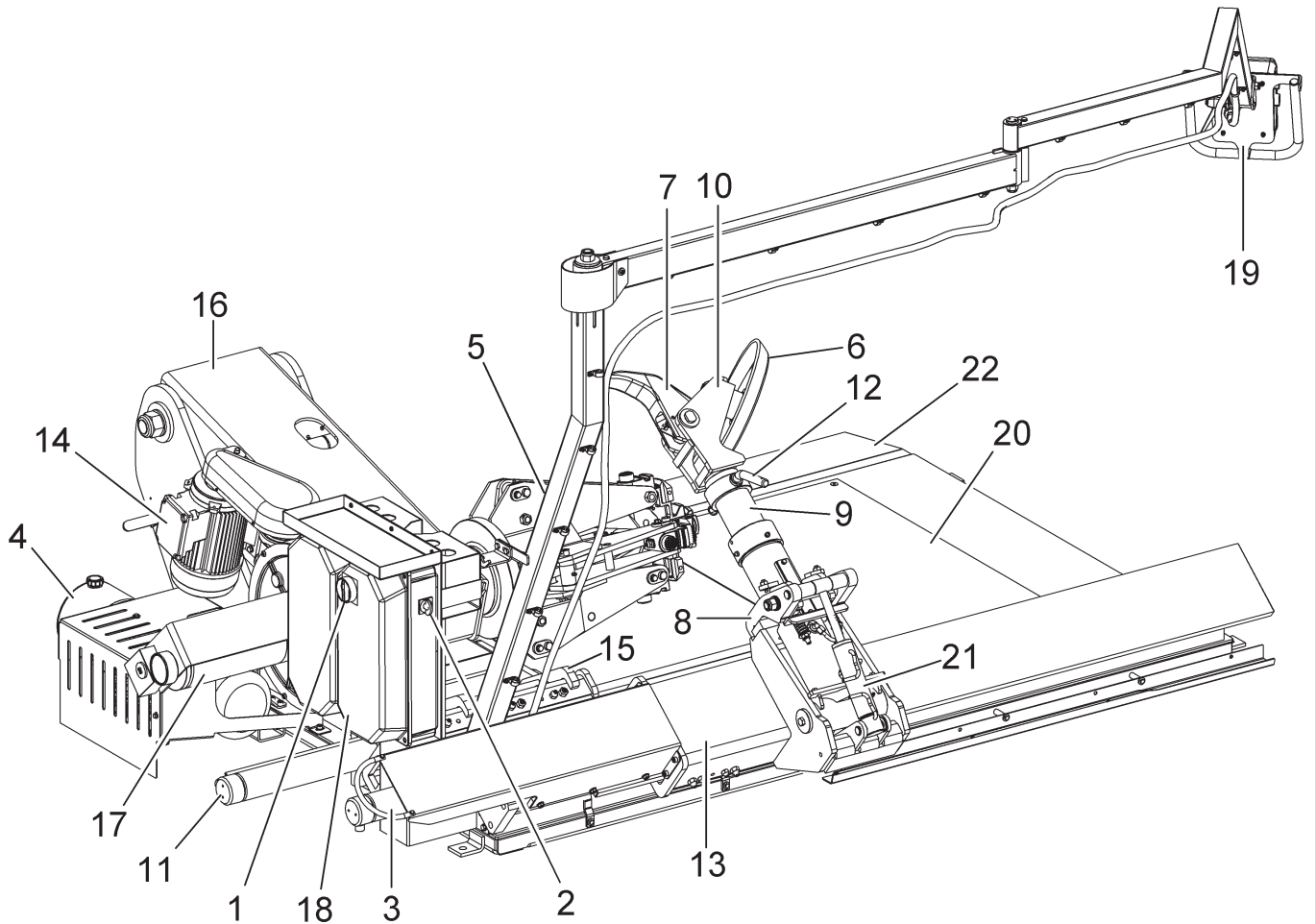
- | | |
|--|--|
| 1 - Main switch | 15 - Mandrel carriage |
| 2 - Selector 1-0-2 self-centring chuck speed control | 16 - Mandrel arm |
| 3 - Tools carriage translation cylinder | 17 - Mandrel opening/closing cylinder |
| 4 - Hydraulic power unit | 18 - Electric panel |
| 5 - Self-centring chuck | 19 - Control unit |
| 6 - Bead breaking disc | 20 - Platform |
| 7 - Tool | 21 - Tools holder arm unlock cylinder |
| 8 - Jack | 22 - Ramp |
| 9 - Tool holder arm | 23 - Handle control in air (aerial handle control version - VARGNAV43ASL) (inverter version - VARGNAV43AD) |
| 10 - Tools unit | 24 - Inverter version |
| 11 - Mandrel carriage translation cylinder | 25 - Inverter (inverter version - VARGNAV43AD) |
| 12 - Quick fit tool | 26 - Electric panel (aerial handle control version - VARGNAV43ASL) (inverter version - VARGNAV43AD) |
| 13 - Tools carriage | |
| 14 - Mandrel rotation motor | |

FIG. 6 - G10360.15 - G10360T.15 - G10360D.15 - G10360TD.15**KEY**

- | | |
|--|---|
| 1 - Main switch | 20 - Platform |
| 2 - Selector 1-0-2 self-centring chuck speed control | 21 - Tools holder arm unlock cylinder |
| 3 - Tools carriage translation cylinder | 22 - Ramp |
| 4 - Hydraulic power unit | 23 - Inverter (only for G10360D.15 - G10360TD.15 versions) |
| 5 - Self-centring chuck | 24 - 1-2-3 Selector self-centring speed control (only for G10360D.15 - G10360TD.15 versions) |
| 6 - Bead breaking disc | 25 - Tool unit (only for G10360T.15 - G10360TD.15 versions) |
| 7 - Tool | 26 - Handle control in air (aerial handle control version only for G10360.15 - G10360T.15 (VARGNAV63A.15) versions (aerial handle control version only for G10360D.15 - G10360TD.15 (VARGNAV63AD) versions) |
| 8 - Jack | 27 - Control unit (bluetooth version only for G10360.15 and G10360T.15 (VARGNAVBTH) versions) (bluetooth version only for G10360D.15 and G10360TD.15 (VARGNAVBDBTH) versions) |
| 9 - Tool holder arm | |
| 10 - Tools unit | |
| 11 - Mandrel carriage translation cylinder | |
| 12 - Tool unit positioning lever | |
| 13 - Tools carriage | |
| 14 - Mandrel rotation motor | |
| 15 - Mandrel carriage | |
| 16 - Mandrel arm | |
| 17 - Mandrel opening/closing cylinder | |
| 18 - Electric panel | |
| 19 - Control unit | |








FIG. 7 - G10360A.15















KEY

- | | |
|--|---------------------------------------|
| 1 - Main switch | 12 - Tool unit positioning lever |
| 2 - Selector 1-0-2 self-centring chuck speed control | 13 - Tools carriage |
| 3 - Tools carriage translation cylinder | 14 - Mandrel rotation motor |
| 4 - Hydraulic power unit | 15 - Mandrel carriage |
| 5 - Self-centring chuck | 16 - Mandrel arm |
| 6 - Bead breaking disc | 17 - Mandrel opening/closing cylinder |
| 7 - Tool | 18 - Electric panel |
| 8 - Jack | 19 - Control unit |
| 9 - Tool holder arm | 20 - Platform |
| 10 - Tools unit | 21 - Tools holder arm unlock cylinder |
| 11 - Mandrel carriage translation cylinder | 22 - Ramp |

SYMBOLS USED IN THE MANUAL AND ON THE MACHINE

Symbols	Description
 *	Read instruction manual.
 *	FORBIDDEN!
 * B2167000	Wear work gloves.
 *	Wear work shoes.
 * B2167000	Wear safety goggles.
 *	Wear safety earcaps.
 99990758	Shock hazard.
 999911770	Danger! Moving mechanical parts.
 *	Caution: hanging loads.
 *	Mandatory. Operations or jobs to be performed compulsorily.
 *	Danger! Be particularly careful.
	Warning. Be particularly careful (possible material damages).

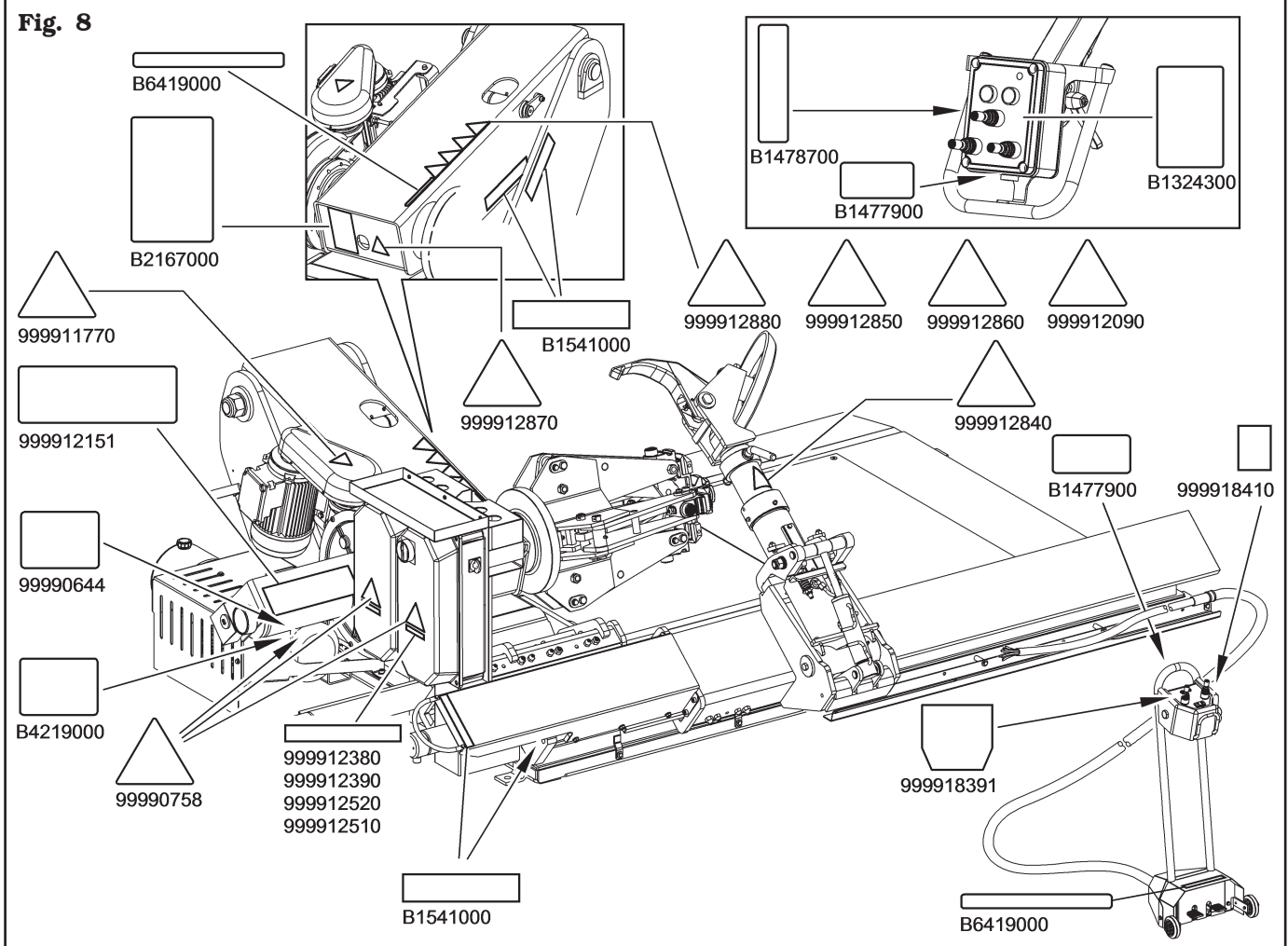
Symbols	Description
 *	Move with fork lift truck or pallet truck.
 *	Lift from above.
 B1541000	General danger.
 *	Technical assistance necessary. Do not perform any intervention.
 999912870	Risk of crushing and collisions (self-centring chuck)
 999912880	Risk of crushing and collisions (self-centring chuck)
 999912850	Risk of limb crushing.
 999912860	Risk of limb crushing.
 999912840	Risk of crushing and collisions (tools holder shaft)
 999912090	Danger: tyres could drop.
 B6419000	Mandrel rotation index plate.
 *	Note. Indication and/or useful information.

* General signalling used in this manual.



PLATES LOCATION ON MACHINE INFORMATION TABLE

Fig. 8



Code numbers of plates

B1478700	Tool arm rotation indicating plate (only for G9256A.15 - G10360A.15) (VARGNAV43A) (VARGNAV63A.15) (VARGNAV63AD)
B1477900	Label for double speed of handle control in air
B1324300	Plate for joysticks (only for G9256A.15 - G10360A.15) (VARGNAV43A) (VARGNAV43AD) (VARGNAV43ASL) (VARGNAV63A.15) (VARGNAV63AD)
B1541000	Danger plate
B2167000	Obligation to wear protective clothing plate
B4219000	Rotation indicating plate
B6419000	Mandrel rotation index plate (only for G9256.11SL - G9256.11ST - G9256.15 - G9256T.15 - G9256D.15 - G9256TD.15 - G9256.15SL - G10360.15 - G10360T.15 - G10360D.15 - G10360TD.15) (VARGNAV63AD)
99990644	Mandrel rotation index plate.
999912380	400V 50 Hz 3 Ph plate

999912390	230V 50 Hz 3 Ph plate
999912520	380V 60 Hz 3 Ph plate
999912510	220V 60 Hz 3 Ph plate
999912090	Tyres fall danger plate
999911770	Unit move indicating plate
999912151	Short instructions for truck tyre changer label
999912850	Danger plate 2
999912860	Danger plate 3
999912870	Danger plate 4
999912880	Danger plate 5
999912840	Danger plate 1
99990758	Electricity danger plate
999918410	Self-centring label
999918391	Handle control label
•	Serial number plate
*	Machine nameplate
♦	Manufacturer name plate



IF ONE OR MORE PLATES DISAPPEAR FROM THE MACHINE OR BECOMES DIFFICULT TO READ, IT MUST BE REPLACED. QUOTE THE CODE NUMBER WHEN REORDERING.



NOTE: SOME OF THE PICTURES PRESENT IN THIS MANUAL HAVE BEEN OBTAINED FROM PICTURES OF PROTOTYPES, THEREFORE THE STANDARD PRODUCTION MACHINES AND ACCESSORIES CAN BE DIFFERENT IN SOME COMPONENTS.

1.0 GENERAL INTRODUCTION

This manual is an integral part of the product and must be retained for the whole operating life of the machine.

Carefully study the warnings and instructions contained in this manual. It contains important instructions regarding **FUNCTIONING, SAFE USE and MAINTENANCE.**



KEEP THE MANUAL IN A KNOWN, EASILY ACCESSIBLE PLACE FOR ALL ACCESSORY OPERATORS TO CONSULT IT WHENEVER IN DOUBT.



THE MANUFACTURER DISCLAIMS ALL RESPONSIBILITY FOR ANY DAMAGE OCCURRED WHEN THE INDICATIONS GIVEN IN THIS MANUAL ARE NOT RESPECTED: AS A MATTER OF FACT, THE NON-COMPLIANCE WITH SUCH INDICATIONS MIGHT LEAD TO EVEN SERIOUS DANGERS.

1.1 Introduction

Thank you for preferring this electro-hydraulic tyre changer. We feel sure you will not regret your decision. This machine has been designed for use in professional workshops and in particular it stands out for its reliability and easy, safe and rapid operation: with just a small degree of maintenance and care, this tyre changer will give you many years of trouble-free service and lots of satisfaction.

2.0 INTENDED USE

The electrohydraulic functioning tyre changing machines model "G9256.11SL, G9256.11ST, G9256.15, G9256T.15, G9256A.15, G9256D.15, G9256TD.15, G9256.15SL, G10360.15, G10360T.15, G10360A.15, G10360D.15, G10360TD.15" with relevant versions, must be used only for the assembly and disassembly of any type of whole (grooved and with bead wire) rim wheel, with the maximum dimensions of 2360 mm/93" (G9256.11SL, G9256.11ST, G9256.15, G9256T.15, G9256A.15, G9256D.15, G9256TD.15 and G9256.15SL) - 2700 mm/106" (G10360.15, G10360T.15, G10360A.15, G10360D.15 and G10360TD.15) and maximum weight of 2000 Kg (G9256.11SL, G9256.11ST, G9256A.15, G9256D.15 and G9256TD.15) - 2300 Kg (G9256.15, G9256T.15, G9256.15SL, G10360A.15, G10360D.15 and G10360TD.15) - 2600 Kg (G10360.15 and G10360T.15).

The machines model "G9256.11SL, G9256.11ST, G9256.15, G9256T.15, G9256A.15, G9256D.15, G9256TD.15, G9256.15SL, G10360.15, G10360T.15, G10360A.15, G10360D.15, G10360TD.15" with relevant versions, **MUST NOT** be used for tyre inflation.



THIS MACHINE MUST BE USED STRICTLY FOR THE INTENDED PURPOSE IT WAS DESIGNED FOR (AS INDICATED IN THIS MANUAL). ANY OTHER USE WILL BE CONSIDERED IMPROPER USE. IN PARTICULAR BEAD FITTING AND INFLATING MUST BE CARRIED OUT IN A SPECIALLY APPROVED INFLATION CAGE.



THE MANUFACTURER CANNOT BE HELD RESPONSIBLE FOR ANY DAMAGE CAUSED BY IMPROPER, ERRONEOUS, OR UNACCEPTABLE USE.



AN INTENSIVE USE OF THE EQUIPMENT IN INDUSTRIAL ENVIRONMENT IS NOT RECOMMENDED.

2.1 Training of personnel

The machine may be operated only by suitably trained and authorized personnel.

Given the complexity of the operations necessary to manage the machine and to carry out the operations safely and efficiently, the personnel must be trained in such a way that they learn all the information necessary to operate the machine as intended by the manufacturer.



A CAREFUL READING OF THIS INSTRUCTION MANUAL FOR USE AND MAINTENANCE AND A SHORT PERIOD OF TRAINING WITH SKILLED PERSONNEL CAN BE AN ENOUGH PREVENTIVE PREPARATION.

3.0 SAFETY DEVICES



PERIODICALLY, AT LEAST MONTHLY, CHECK THE INTEGRITY AND THE FUNCTIONALITY OF THE SAFETY AND PROTECTION DEVICES ON THE MACHINE.

All the machines are equipped with:

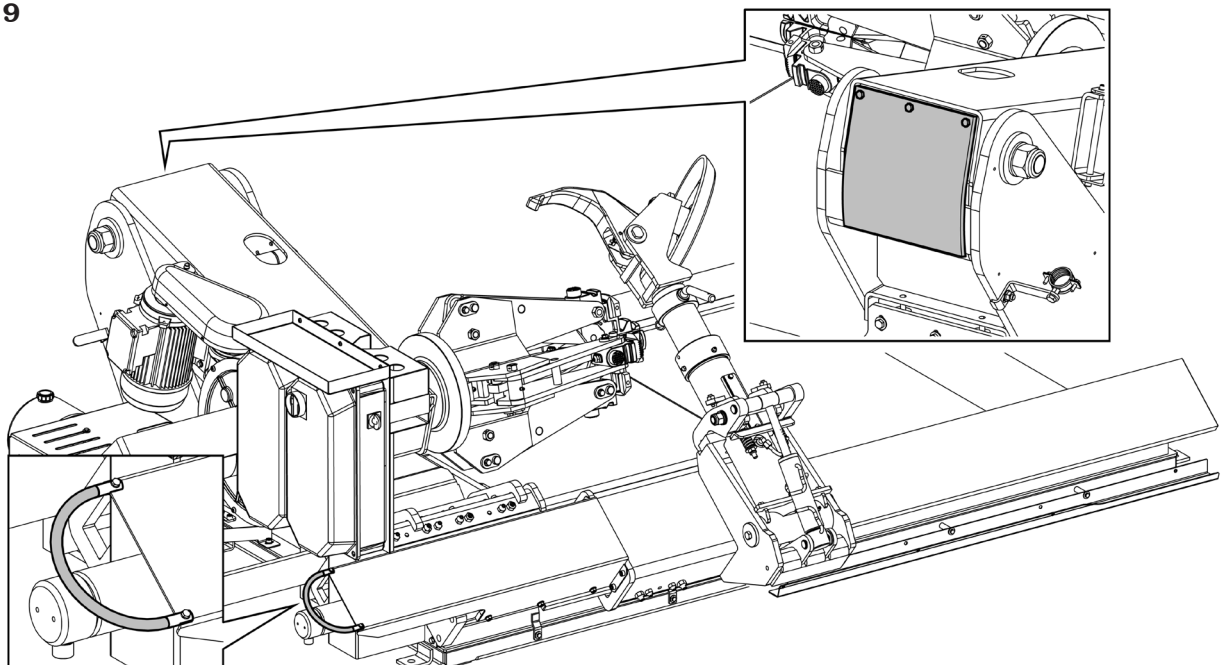
- “man-operated” controls (immediate stop of operation when the control is released).
- **Controls logic disposition**
To prevent the operator from making dangerous mistakes.
- thermal magnetic switch on the supply line of the oil-pressure power unit motor: avoids the motor overheating in case of intensive use.



NO MODIFICATION OR CALIBRATION OF THE OPERATING PRESSURE OF THE MAXIMUM PRESSURE VALVE OR OF THE HYDRAULIC CIRCUIT PRESSURE LIMITER IS PERMITTED

- controlled check valves on:
 - opening of clamping unit jaws,
 - mandrel arm lifting,
 - tool holder arm tilting (only for versions foreseeing such operation).
These valves have been fit in order to avoid unexpected movements of the jaws, tool or mandrel arm (and, as a consequence, the wheel fall) caused by accidental oil drippings.
- Fuses on the electric supply line of the clamping unit motor,
- Automatic power supply disconnection with the opening of the electric panel.
- Mandrel self-braking motor (only for G9256.15, G9256T.15, G9256A.15, G9256D.15, G9256TD.15, G10360.15, G10360T.15, G10360A.15, G10360D.15 and G10360TD.15).
- Mandrel self-braking motor (on demand only for G9256.11SL, G9256.11ST and G9256.15SL).
- **Motor protection devices** (only for G9256D.15, G9256TD.15, G10360D.15 and G10360TD.15)
The new “Invemotor” unit is equipped with electronic protection devices. They stop the motor if working defected conditions appear to avoid that the motor itself can be damaged and that the operator safety can be compromised (overvoltage, undervoltage, overload, overtemperature).
For more details, see Chapt. 14 “Troubleshooting table”.

Fig. 9



• Fixed guards and shelters

The machine is fitted with a number of fixed guards intended to prevent potential crushing, cutting and compression risks. These protections have been realized after risks evaluation and after all machine operative situations have been considered. These protections can be located in the figure below.

3.1 Residual risks

The machine was subjected to a complete analysis of risks according to reference standard EN ISO 12100. Risks are as reduced as possible in relation with technology and product functionality.

Possible residual risks have been emphasized through pictorial representations and warnings which placing is indicated in " PLATE POSITIONING TABLE" at page 10.

4.0 GENERAL SAFETY RULES



- Any tampering with or modification to the machine not previously authorized by the manufacturer exempts the latter from all responsibility for damage caused by or derived from said actions.
- Removing of or tampering with the safety devices or with the warning signals placed on the machine leads to serious dangers and represents a transgression of European safety rules.
- Use of the machine is only permitted in places free from **explosion** or **fire** hazard and in **dry places under cover**.
- Original spare parts and accessories should be used.



THE MANUFACTURER DENIES ANY RESPONSIBILITY IN CASE OF DAMAGES CAUSED BY UNAUTHORIZED MODIFICATIONS OR BY THE USE OF NON ORIGINAL COMPONENTS OR EQUIPMENT.

- Installation must be conducted only by qualified personnel exactly according to the instructions that are given below.
- Ensure that there are no dangerous situations during the machine operating manoeuvres. Immediately stop the machine if it miss-functions and contact the assistance service of an authorized dealer.
- In emergency situations and before carrying out any maintenance or repairs, disconnect all supplies to the machine by using the main switch.
- The machine electrical supply system must be equipped with an appropriate earthing, to which the yellow-green machine protection wire must be connected.

- Ensure that the work area around the machine is free of potentially dangerous objects and that there is no oil since this could damage the tyre. Oil on the floor is also a potential danger for the operator.



OPERATORS MUST WEAR SUITABLE WORK CLOTHES, PROTECTIVE GLASSES AND GLOVES, AGAINST THE DANGER FROM THE SPRAYING OF DANGEROUS DUST, AND POSSIBLY LOWER BACK SUPPORTS FOR THE LIFTING OF HEAVY PARTS. DANGLING OBJECTS LIKE BRACELETS MUST NOT BE WORN, AND LONG HAIR MUST BE TIED UP. FOOTWEAR SHOULD BE ADEQUATE FOR THE TYPE OF OPERATIONS TO BE CARRIED OUT.



- The machine handles and operating grips must be kept clean and free from oil.
- The workshop must be kept clean, dry and not exposed to atmospheric agents. Make sure that the working premises are properly lit. The machine can be operated by a single operator. Unauthorized personnel must remain outside the working area, as shown in **Fig. 12**. Avoid any hazardous situations. Do not use air-operated or electrical equipment when the shop is damp or the floor slippery and do not expose such tools to atmospheric agents.
- When operating and servicing this machine, carefully follow all applicable safety and accident-prevention precautions. The machine must not be operated by professionally unskilled persons.



THE MACHINE OPERATES WITH PRESSURIZED HYDRAULIC FLUID. MAKE SURE EVERY COMPONENT OF THE HYDRAULIC CIRCUIT IS ALWAYS PROPERLY LOCKED, ANY PRESSURIZED LEAKS MAY CAUSE SERIOUS INJURIES OR WOUNDS.



IN CASE OF A CHANCE SUPPLY FAILURE (WHETHER ELECTRICITY OR COMPRESSED AIR), MOVE THE CONTROLS TO THE NEUTRAL POSITION.

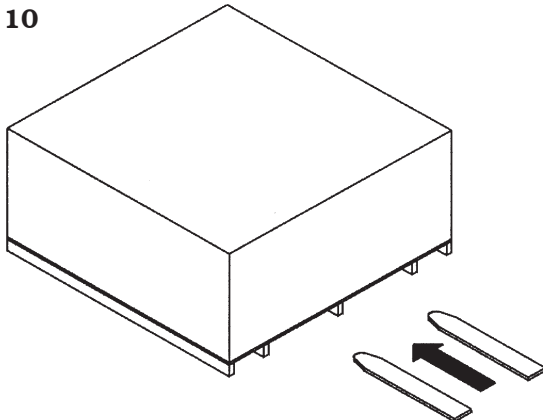
5.0 PACKING AND MOBILIZATION FOR TRANSPORT



HAVE THE MACHINE HANDLED BY SKILLED PERSONNEL ONLY.
THE LIFTING EQUIPMENT MUST WITHSTAND A MINIMUM RATED LOAD EQUAL TO THE WEIGHT OF THE PACKED MACHINE (SEE PARAGRAPH "TECHNICAL SPECIFICATIONS").

The machine is packed completely assembled. The cardboard box containing the machine is fixed onto a pallet and measures mm 2105x2085x1030. The displacement must be performed through adequate lifting device (pallet truck or fork lift truck). Lift the packaging as indicated in **Fig. 10** (forks introduced in the middle to ensure a correct loads distribution).

Fig. 10



6.0 UNPACKING



DURING UNPACKING, ALWAYS WEAR GLOVES TO PREVENT ANY INJURY CAUSED BY CONTACT WITH PACKAGING MATERIAL (NAILS, ETC.).

After removing the packing, and in the case of the machine packed fully assembled, check that the machine is complete and that there is no visible damage. If in doubt **do not use the machine** and refer to professionally qualified personnel (to the seller). The packaging elements (plastic bags, polystyrene foam, nails, screws, wood, etc.) must be collected up and disposed of through according to the in force laws, except for the pallet, which could be used again for subsequent machine handling.



THE BOX CONTAINING THE FIXTURES IS CONTAINED IN THE WRAPPING. DO NOT THROW IT AWAY WITH THE PACKING.

7.0 MOBILIZATION

If the machine has to be moved.

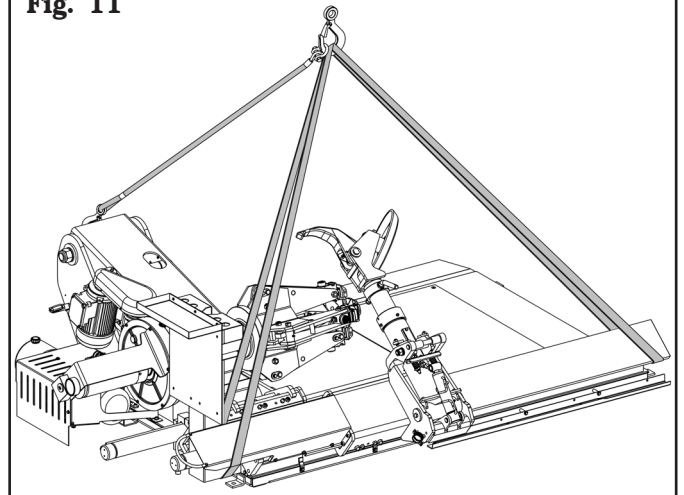


THE LIFTING EQUIPMENT MUST WITHSTAND A MINIMUM RATED LOAD EQUAL TO THE WEIGHT OF THE MACHINE (SEE PARAGRAPH TECHNICAL SPECIFICATIONS). DO NOT ALLOW THE LIFTED MACHINE TO SWING.

If the machine has to be moved from its normal work post, the movement must be conducted following the instructions listed below.

- Protect the exposed corners with suitable material (Pluribol/cardboard).
- Do not use metallic cables for lifting.
- Move the mandrel to completely lowered position and in the centre of the machine in order to ensure a correct load balancing.
- Move the tool carriage to limit switch towards the mandrel.
- Disconnect all machine power supply sources.
- Sling with three sufficiently long belts (300 cm at least) and with capacity load at least equal to machine weight (see **Fig. 11**).
- Lift and transport with suitable device with adequate dimensions.

Fig. 11



8.0 WORKING ENVIRONMENT CONDITIONS

The machine must be operated under proper conditions as follows:

- temperature: 0° + 55° C
- relative humidity 30 - 95% (dew-free)
- atmospheric pressure: 860 - 1060 hPa (mbar).

The use of the machine in ambient conditions other than those specified above is only allowed after prior agreement with and approval of the manufacturer.

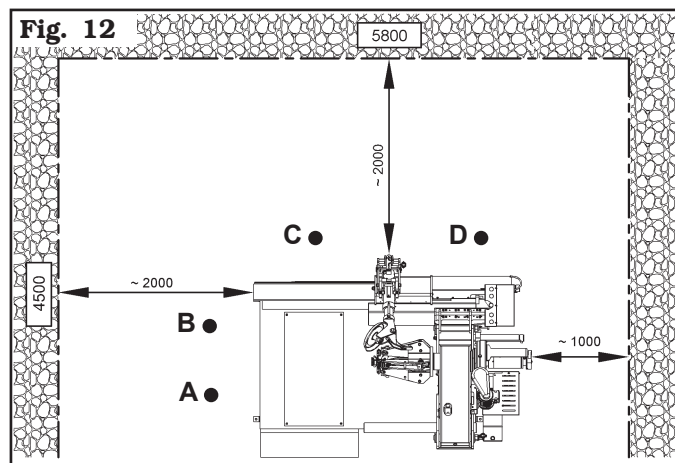
8.1 Working position

In **Fig. 12** it's possible to define working positions **A**, **B**, **C**, **D** which will be referred to in the description of machine operative phases.

Positions **A** and **B** must be considered as main positions for tyre mounting and demounting and for wheel clamping on the mandrel, while positions **C** and **D** are the best positions to follow tyre bead breaking and demounting operations.

Working in these positions allows better precision and speed during operating phases as well as greater safety for the operator.

8.2 Installation space




INSTALL THE MACHINE INDOORS OR IN A ROOFED AREA. PLACE OF INSTALLATION MUST BE DRY, ADEQUATELY LIT AND IN COMPLIANCE WITH APPLICABLE SAFETY REGULATIONS.

The location of the machine requires a usable space of 5800x4500 mm, (as indicated in **Fig. 12**). The positioning of the machine must be according to the distances shown. From the control position the operator is able to observe all the machine and surrounding area. He must prevent unauthorized personnel or objects that could be dangerous from entering the area. The machine must be fixed on a flat floor surface, pre-

ferably of cement or tiled. Avoid yielding or irregular surfaces.

The base floor must be able to support the loads transmitted during operation. This surface must have a capacity load of at least 500 kg/m².

The depth of the solid floor must be sufficient to guarantee that the anchoring bolts hold.

8.3 Lighting

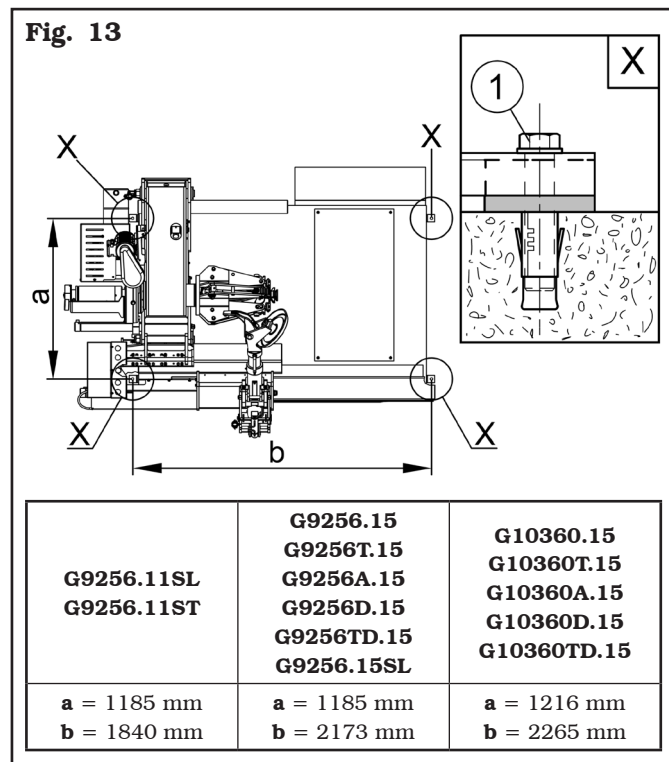
The machine does not require its own lighting for normal working operations. However, it must be placed in an adequately lit environment.

For correct lighting, use lamps having total power 800/1200 Watt as envisaged by UNI 10380.

9.0 MACHINE ASSEMBLY

9.1 Anchoring system

The packed machine is fixed to the pallet through the holes prearranged on the frame. Such holes also fix the machine to the ground through anchor small blocks as shown in **Fig. 13**.



- Execute four holes with 12 mm diameter on the floor by the holes on the bottom floor;
- introduce the small blocks in the holes;
- fix the machine to the ground with four M12x120 mm screws (or four 12x80 mm stud bolts). Tighten the screws with an approximate tightening torque of 70 Nm.

9.2 Fixtures contained in the packing

The packing case contains also the fixtures box.
Check that all the parts listed are there.

Code	Description	N.
14620010	Clamp	1
B5119000	Long lever "A"	1

10.0 ELECTRICAL CONNECTIONS

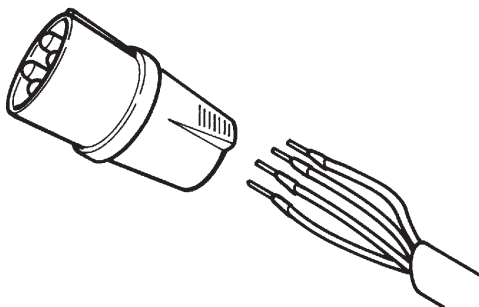


EVEN THE TINIEST PROCEDURE OF AN ELECTRICAL NATURE MUST BE CARRIED OUT BY PROFESSIONALLY QUALIFIED STAFF.



BEFORE CONNECTING THE MACHINE MAKE SURE THAT:

- THE MAIN POWER RATING CORRESPONDS TO THE MACHINE RATING AS SHOWN ON THE MACHINE PLATE;
- ALL MAIN POWER COMPONENTS ARE IN GOOD CONDITION;
- THE ELECTRICAL SYSTEM IS PROPERLY GROUNDED (GROUND WIRE MUST BE THE SAME CROSS-SECTION AREA AS THE LARGEST POWER SUPPLY CABLES OR GREATER);
- MAKE SURE THAT THE ELECTRICAL SYSTEM FEATURES A CUTOUT WITH DIFFERENTIAL PROTECTION SET AT 30 mA.



The machine is supplied with 5 m of free cable. A plug corresponding to the following requirements must be connected to the cable:

- Conformity to Norm **IEC 309**
- **230/400 Volt – 16A**
- **3P + Ground**
- **IP 44**

Only for G9256D.15, G9256TD.15, G9256.11SL (VARGNAV43AD), G9256.15SL (model with inverter version) (VARGNAV43AD) G10360D.15 and G10360TD.15 versions

- Conformity to Norm **IEC 309**
- **230/400 Volt – 32A**
- **3P + N + Ground**
- **IP 44**

On delivery, the machine is pre-set to operate at a voltage of 400 V.

For any other type of power supply, ask the manufacturer at the time of purchase: a machine functioning under the required voltage conditions will be prepared.



FIT A TYPE-APPROVED (AS REPORTED BEFORE) PLUG TO THE MACHINE CABLE (THE GROUND WIRE IS YELLOW/GREEN AND MUST NEVER BE CONNECTED TO ONE OF THE PHASE LEADS).



MAKE SURE THAT THE ELECTRICAL SYSTEM IS COMPATIBLE WITH THE RATED POWER ABSORPTION SPECIFIED IN THIS MANUAL AND APT TO ENSURE THAT VOLTAGE DROP UNDER FULL LOAD WILL NOT EXCEED 4% OF RATED VOLTAGE (10% UPON START-UP).



IN CASE OF A CHANCE SUPPLY FAILURE, AND/OR BEFORE ANY POWER SUPPLY CONNECTIONS, MOVE THE PEDALS TO THE NEUTRAL POSITION.

10.1 Oil check on oil-pressure power unit



THE OIL-PRESSURE POWER UNIT IS DELIVERED WITHOUT HYDRAULIC OIL, THEREFORE MAKE SURE THE TANK PROVIDED IS FILLED WITH OIL WITH VISCOSITY DEGREE APPROPRIATE TO THE AVERAGE TEMPERATURES IN THE INSTALLATION COUNTRY AND IN PARTICULAR:

- **VISCOSITY 32 (FOR COUNTRIES WITH ROOM TEMPERATURE FROM 0 TO 30 DEGREES);**
- **VISCOSITY 46 (FOR COUNTRIES WITH ROOM TEMPERATURE ABOVE 30 DEGREES).**

10.2 Check of motor rotation direction

Once the last electrical connection has been terminated, power the machine with the main switch. Make sure the motor of the hydraulic power unit rotates in the direction indicated by the arrow (Fig. 14 ref. B) visible on the electric motor cap. If rotation should occur in the opposite direction, the machine must be immediately stopped and phase inversion must be executed inside the plug connection in order to reset the correct rotation direction.



FAILURE TO OBSERVE THE ABOVE INSTRUCTIONS WILL IMMEDIATELY INVALIDATE THE WARRANTY.

10.3 Electrical checks



BEFORE STARTING UP THE TYRE-CHANGER, BE SURE TO BECOME FAMILIAR WITH THE LOCATION AND OPERATION OF ALL CONTROLS AND CHECK THEIR PROPER OPERATION (SEE PAR. "CONTROLS").



CARRY OUT A DAILY CHECK OF MAINTAINED-TYPE CONTROLS CORRECT FUNCTIONING, BEFORE STARTING MACHINE OPERATION.

Once the plug/socket connection has been made, turn on the machine using the master switch (Fig. 14 ref. A).

Only for VARGNAVBTH (G9256.15 - G9256T.15 - G10360.15 - G10360T.15) and VARGNAVDBTH (G9256D.15 - G9256TD.15 - G10360D.15 - G10360TD.15) versions

Then horizontally or vertically move the lever (Fig. 16 ref. H): the red LED (Fig. 16 ref. B) will turn on. Wait a few seconds for the green LED turning on (Fig. 16 ref. A) and then release the lever (Fig. 16 ref. H).

In the end, the green LED (Fig. 16 ref. A) flashes to indicate that the machine is ready for operation.

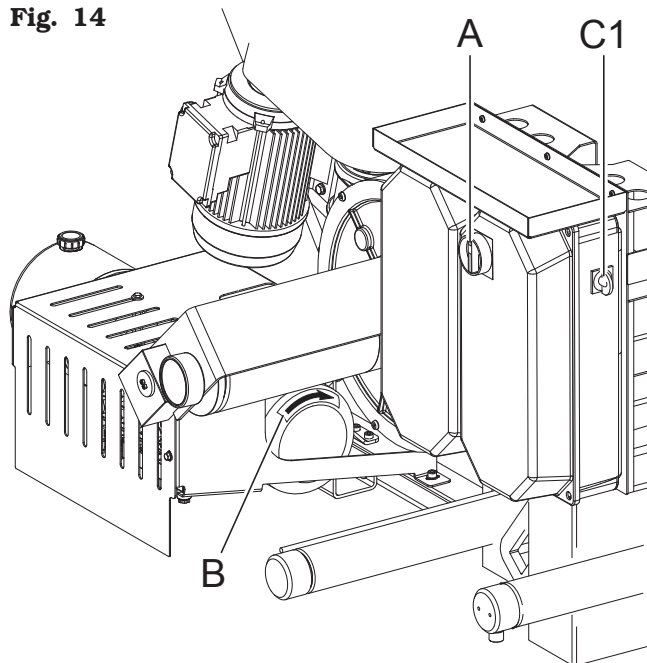
N.B.: when a control is operated, the green LED (Fig. 16 ref. A) light is fixed: it flashes again when it is released.

ONCE THE ASSEMBLY OPERATIONS HAVE BEEN ENDED, CHECK ALL MACHINE FUNCTIONS.

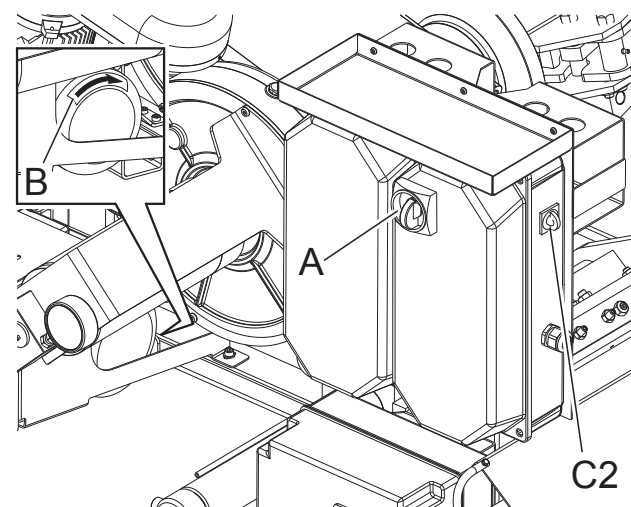
If during the operations the red LED (Fig. 16 ref. A) turns on and the green led turns off, charge the control batteries with the provided socket for battery charger, located under the control (Fig. 16 ref. M).

The machine is equipped with a device for the interruption of the communication between the control and the electrical panel, when more than 6 hours have passed after the last executed control. In this case, just repeat the turning on operations described in the "Electrical checks" chapter.

Fig. 14



Only for G9256D.15, G9256TD.15, G9256.11SL (VARGNAV43AD), G9256.15SL (model with inverter version) (VARGNAV43AD) G10360D.15 and G10360TD.15 versions



KEY

A – Main switch

B – Rotation direction of power unit motor

C1 – Selector 1-0-2 for self-centring chuck speed control

C2 – Selector 1-2-3 for self-centring chuck speed control

11.0 CONTROLS

11.1 Cable control device

The control (handle control) can be moved according to the positioning necessities of the operator.

The operator should place the control in a zone free from obstacles in order to see clearly and completely the operative zone.



MAKE SURE THERE ARE NO PERSONS OR OBJECTS HIDDEN TO THE OPERATOR VISUAL FIELD BY THE WHEEL SIDE PLAY (ESPECIALLY IN CASE OF WHEELS WITH LARGE DIMENSIONS).

The “lever **A**” has four maintained control operative positions:

- Lever rightwards or leftwards, operates respectively the mandrel holder carriage shifting rightwards or leftwards.
- Lever upwards or downwards: it operates respectively the rising and the lowering of the mandrel holding arm.

“Pedal **B**” controls mandrel clockwise and counter-clockwise rotation.

“Button **C**” has one “hands-on” operating position, and when pressed, it operates the counter-clockwise rotation of the tool holder head (from behind the tool) (G9256.15, G9256T.15, G9256D.15, G9256TD.15, G10360.15, G10360T.15, G10360D.15 and G10360TD.15).

“Button **D**” has one “hands-on” operating position, and when pressed, it operates the clockwise rotation of the tool holder head (from behind the tool) (G9256.15, G9256T.15, G9256D.15, G9256TD.15, G10360.15, G10360T.15, G10360D.15 and G10360TD.15).

“Push-button **E**” has a maintained control position, and when pressed, it operates the self-centring chuck opening.

“Push-button **F**” has a maintained control position, and when pressed it operates the self-centring chuck closing.

“Button **G**” has one “hands-on” operating position: when it is pressed and lever “**A**” or “**H**” is laterally shifted at the same time, it doubles the translation speed of the self-centring carriage and of the tool holder carriage respectively.

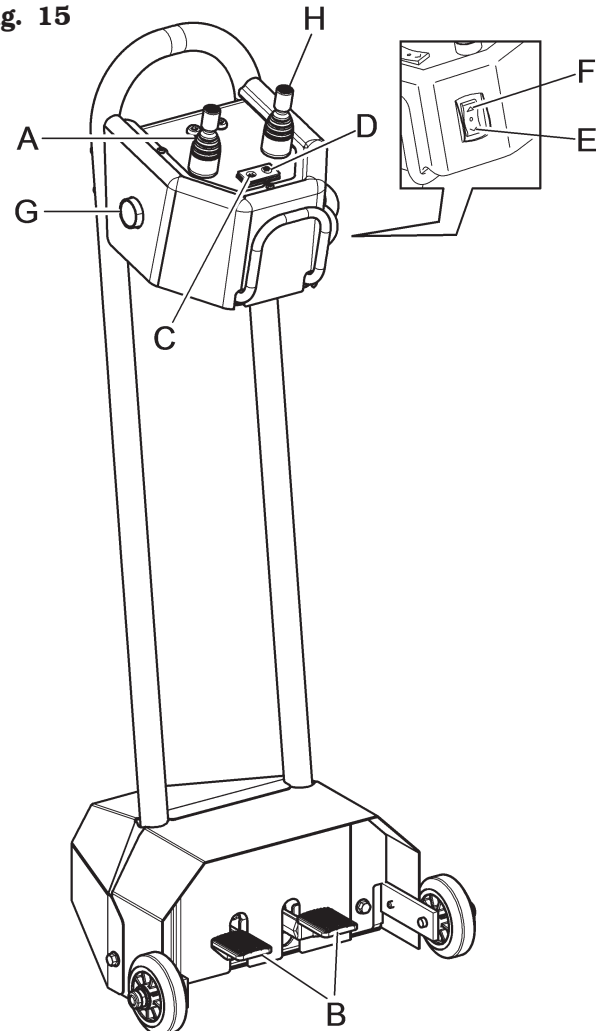
“Lever **H**” has four maintained control positions:

- Lever rightwards or leftwards, operates respectively the tool holder carriage shifting rightwards or leftwards.
- Upwards or downwards lever: it respectively lowers or lifts the tool holder arm (only for G9256.11SL, G9256.15, G9256T.15, G9256D.15, G9256TD.15, G9256.15SL, G10360.15, G10360T.15, G10360D.15 and G10360TD.15 versions).



THE HANDLE MUST NOT BE PLACED WHERE WATER STAGNATES.

Fig. 15



11.2 Control device with bluetooth transmission (optional)

The control (handle control) can be moved according to the positioning necessities of the operator.

The operator should place the control in a zone free from obstacles in order to see clearly and completely the operative zone.



MAKE SURE THERE ARE NO PERSONS OR OBJECTS HIDDEN TO THE OPERATOR VISUAL FIELD BY THE WHEEL SIDE PLAY (ESPECIALLY IN CASE OF WHEELS WITH LARGE DIMENSIONS).

The flashing green led "A", indicates the machine stand-by position. When any control is operated, the machine is started and it is ready for operation. During functioning, the led "A" is turned on with a fixed light. The red turned on led "B" and the green turned off led "A" indicate that the manipulator batteries are exhausted: in order to carry on the functioning, the batteries must be charged.



IN ORDER TO ACTIVATE THE COMMUNICATION BETWEEN HANDLE CONTROL AND MACHINE, ON MACHINE SWITCHING AND AFTER EACH POSITIONING IN STAND-BY MODE, IT'S NECESSARY TO OPERATE ANY JOYSTICK (LEVER "H" OR LEVER "I") FOR 5 SECONDS AT LEAST.

"Push button C" has a maintained control position, and when pressed it rotates the tool holder head counter-clockwise (from behind the tool).

"Push button D" has a maintained control position, and when pressed it rotates the tool holder head clockwise (from behind the tool).

"Push-button E" has a maintained control position, and when pressed, it operates the self-centring chuck opening.

"Push-button F" has a maintained control position, and when pressed it operates the self-centring chuck closing.

"Button G" has one "hands-on" operating position: when it is pressed and lever "I" or "H" is laterally shifted at the same time, it doubles the translation speed of the self-centring carriage and of the tool holder carriage respectively.

"Lever H" has four maintained control positions:

- Lever rightwards or leftwards, operates respectively the tool holder carriage shifting rightwards or leftwards.
- Lever upwards or downwards: it respectively lowers or lifts the tool holder arm.

"Lever I" has four maintained control positions:

- Lever rightwards or leftwards, operates respectively the mandrel holder carriage shifting rightwards or leftwards.
- Lever upwards or downwards: it operates respectively the rising and the lowering of the mandrel holding arm.

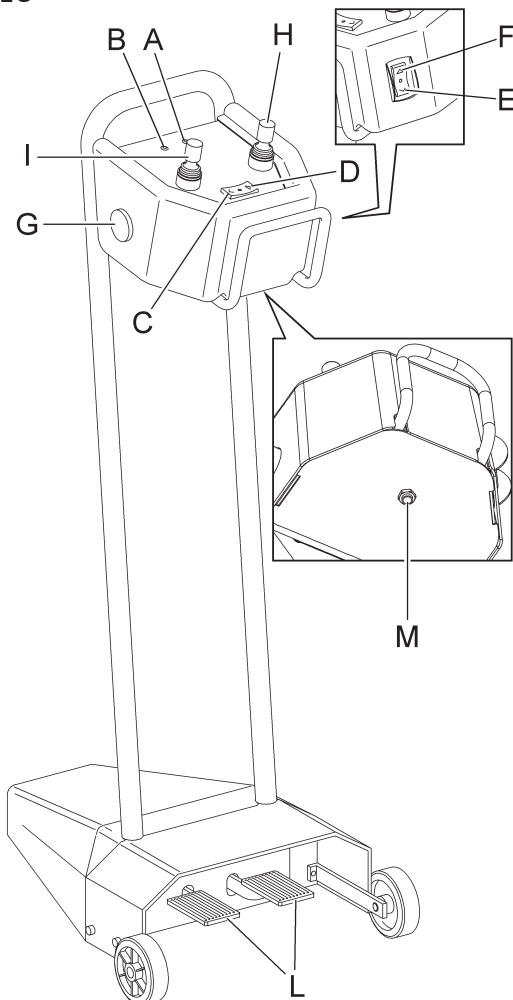
"Pedal L" starts clockwise and anti-clockwise rotation of the mandrel.

When any control is operated, the machine is started again, ready for operation: led "A" flashes.



THE HANDLE MUST NOT BE PLACED WHERE WATER STAGNATES.

Fig. 16





11.3 Handle control in air (standard for G9256A.15 - G10360A.15 versions) (optional for G9256.11SL (VARGNAV43AD - VARGNAV43ASL) - G9256.15SL (VARGNAV43AD - VARGNAV43ASL) - G9256.15 and G9256T.15 (VARGNAV43A) - G10360.15 and G10360T.15 (VARGNAV63A.15) - G10360D.15 and G10360TD.15 (VARGNAV63AD))

The control (handle control) can be moved according to the positioning necessities of the operator.

Lever handling (**Fig. 17 ref. 3**) in **A** position, to “hands-on” operating position, lifts the tool holder arm. Lever handling (**Fig. 17 ref. 1**) in **B**, to “hands-on” operating position, controls the self-centring carriage arm rising.

Lever handling (**Fig. 17 ref. 1**) in **C** position, to “hands-on” operating position, controls the self-centring carriage descent.

Lever handling (**Fig. 17 ref. 1**) in **D** position, to “hands-on” operating position, controls the self-centring carriage right shifting.

Lever handling (**Fig. 17 ref. 3**) in **E** position, to “hands-on” operating position, controls the tools holder carriage right shifting.

Lever handling (**Fig. 17 ref. 1**) in **F** position, to “hands-on” operating position, controls the self-centring carriage left shifting.

Lever handling (**Fig. 17 ref. 3**) in **G** position, to “hands-on” operating position, controls the tools holder carriage left shifting.

Lever handling (**Fig. 17 ref. 3**) in **H** position, to “hands-on” operating position, lowers the tool holder arm.

“Push button **P**” has one “hands-on” operating position, and when pushed in combination with the horizontal movement of levers **3** and/or **1**, it doubles tool-holder or self-centring carriage shifting speed. Pushing push-button “**P**” in combination with the vertical movement of lever “**1**” it doubles the rise or descent speed of the self-centring carriage.

“Lever **2**” has two “hands-on” operating positions: turned to right (**Ref. O**) or to left (**Ref. Q**), it respectively controls clockwise and counter clockwise rotation of the self-centring mandrel.

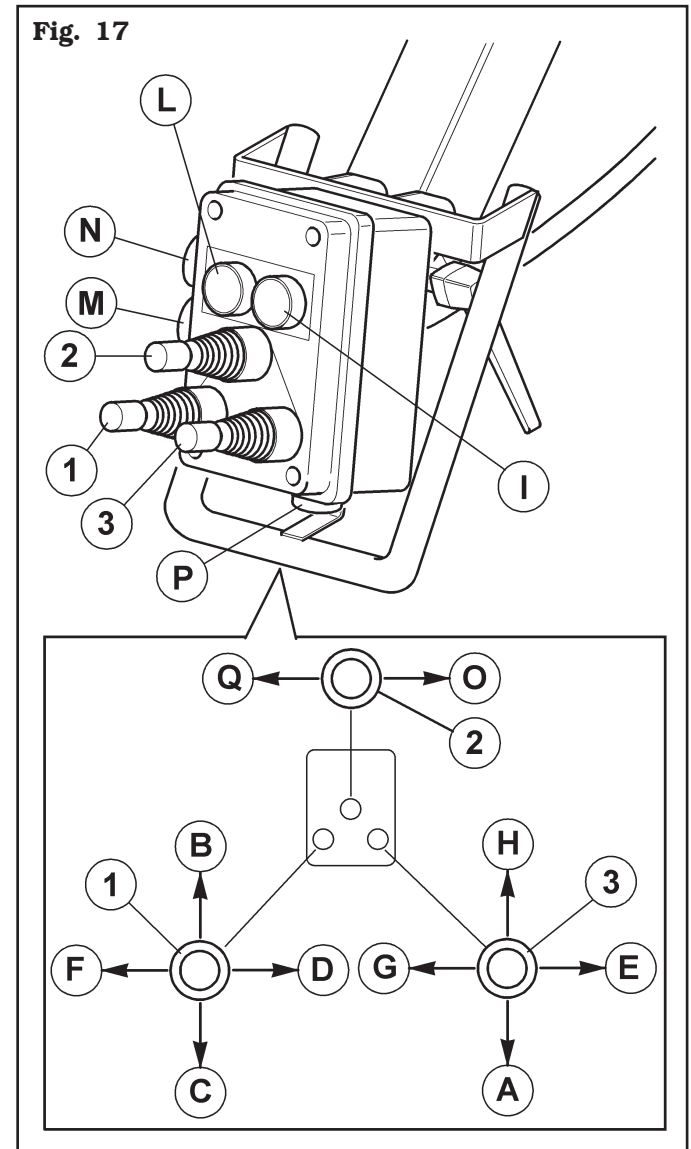
“Push button **I**” has one “hands-on” operating position, and when pressed it opens the mandrel.

“Push button **L**” has one “hands-on” operating position, and when pressed it closes the chuck.

“Push button **M**” has one “hands-on” operating position, and when pressed, it operates tool holder head’s counter-clockwise rotation (from behind the tool) (standard for G9256A.15 - G10360A.15 versions) (optional for G9256.15 and G9256T.15 (VARGNAV43A) - G10360.15 and G10360T.15 (VARGNAV63A.15) - G10360D.15 and G10360TD.15 (VARGNAV63AD) versions).

“Push button **N**” has one “hands-on” operating position, and when pressed, it operates tool holder head’s clockwise rotation (from behind the tool) (standard for G9256A.15 - G10360A.15 versions) (optional for G9256.15 and G9256T.15 (VARGNAV43A) - G10360.15 and G10360T.15 (VARGNAV63A.15) - G10360D.15 and G10360TD.15 (VARGNAV63AD) versions)

Fig. 17



12.0 USING THE MACHINE

12.1 Precaution measures during tyre removal and fitting



Before fitting a tyre, observe the following safety rules:

- always use clean, dry and in good condition rims and tyres; in particular, if necessary, clean the rims after all the balancing weights (as well as the adhesive weights on the inner side) have been removed, and make sure that:
 - neither the bead nor the tread of the tyre are damaged;
 - the rim does not produce dents and/or deformation (especially for alloy rims, dents can cause internal micro-fractures, that pass unobserved at visual inspection, and can compromise the solidity of the rim and constitute danger even during inflation);
- adequately lubricate the contact surface of rim and tyre bead, using specific tyre lubricants only;
- replace the inner tube valve with a new valve, if the tyre tube has a metal valve, replace the grommet;
- make sure that the tyre is the right size for the rim; on the contrary, never fit a tyre unless you are sure it is the right size (the rated size of the rim and tyre is usually printed directly on each of them);
- do not use compressed air or water jets to clean the wheels on the machine.

12.2 Preliminary operations

In view of tyre changer's structure and intended use, the operator will have to treat large diameter wheels (up to 2360 mm for G9256.11SL, G9256.11ST, G9256.15, G9256T.15, G9256A.15, G9256D.15, G9256TD.15, G9256.15SL and up to 2700 mm for G10360.15, G10360T.15, G10360A.15, G10360D.15 and G10360TD.15) and with remarkable mass (up to 2000 kg for G9256.11SL, G9256.11ST, G9256A.15, G9256D.15 and G9256TD.15, up to 2300 kg G9256.15, G9256T.15, G9256.15SL, G10360A.15, G10360D.15, G10360TD.15 and up to 2600 kg for G10360.15 and G10360T.15).

The utmost care while moving the wheels is recommended: make use of other operators, properly trained and with suitable clothes.

DURING ALL TYRES MOUNTING AND DEMOUNTING OPERATIONS, THE SELF-CENTRING CHUCK ROTATION SPEED CAN BE DOUBLED BY ROTATING THE SELECTOR (FIG. 14 REF. C1).

IN CASE OF G9256D.15, G9256TD.15, G9256.11SL (VARGNAV43AD), G9256.15SL (MODEL WITH INVERTER VERSION) (VARGNAV43AD) G10360D.15 AND G10360TD.15 MODELS, USING THE SELECTOR (FIG. 14 REF. C2), SELF-CENTRING CHUCK ROTATION SPEED CAN BE ADJUSTED RESPECTIVELY AT 1, 6 OR 12 RPM. LOW SPEED IS RECOMMENDED FOR WHEELS WITH GREAT DIAMETER AND WEIGHT. 1 RPM IS THE CORRECT SPEED VALUE FOR THE GROOVE OF TRUCK TYRES. LUBRICATE THE TYRE BEADS CAREFULLY TO PROTECT THEM AGAINST ANY DAMAGE AND SIMPLIFY MOUNTING AND DEMOUNTING OPERATIONS.

12.3 Preparing the wheel



REMOVE THE VALVE STEM AND ALLOW THE TYRE TO COMPLETELY DEFLATE.

- Remove the wheel balancing weights from both sides of the wheel.
- Establish from which side the tyre should be demounted, checking the position of the groove.
- Find the rim locking type.

12.4 Wheel clamping



FOR WHAT CONCERNS THE DIMENSIONS AND WEIGHT OF THE WHEEL TO BE LOCKED, MAKE USE OF A SECOND OPERATOR WHO MUST HOLD THE WHEEL INTO VERTICAL POSITION, IN ORDER TO ENSURE SAFE OPERATIVE CONDITIONS.

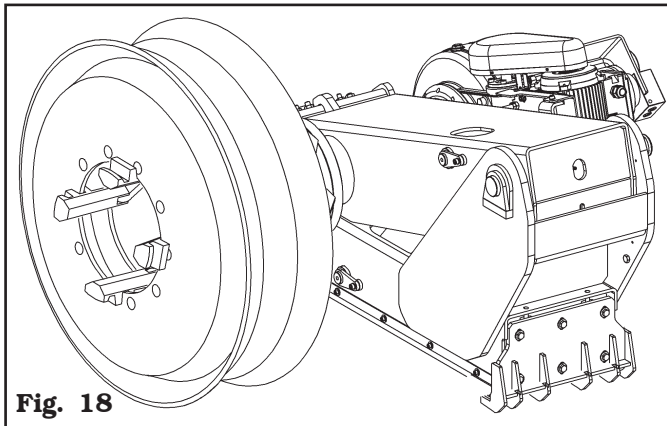
When handling wheels weighing more than 500 Kg a fork-lift truck or a crane should be used.



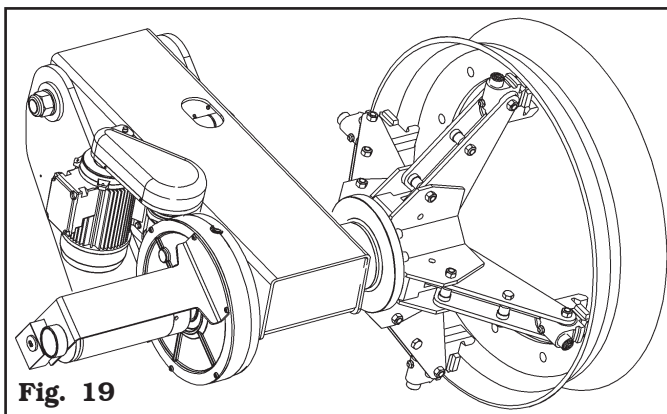
MAKE SURE THAT RIM CLAMPING IS DONE PROPERLY AND THAT THE GRIP IS SAFE, TO PREVENT THE WHEEL FROM FALLING DURING MOUNTING OR REMOVAL OPERATIONS.



DO NOT CHANGE THE SET OPERATING PRESSURE VALUE BY MEANS OF THE MAXIMUM PRESSURE VALVES. THE MANUFACTURER SHALL NOT BE RESPONSIBLE FOR INJURY OR DAMAGE ARISING FROM UNAUTHORISED CHANGES.


Fig. 18

Clamping on the central hole


Fig. 19

Clamping on bead seat



OPENING/CLOSING MOVEMENT OF THE SELF-CENTRING MANDREL CAN GENERATE DANGER OF SQUASHING, CUTTING, COMPRESSING. DURING WHEEL LOCKING/UNLOCKING PHASE, AVOID THAT PARTS OF HUMAN BODY COME INTO CONTACT WITH MOVING PARTS OF THE MACHINE.

All wheels must be clamped from the inside.

Clamping on the central flange is always safest. NOTE: for wheels with grooved rims secure the wheel so the groove is facing outward compared to the mandrel.

If it is not possible to clamp the rim in the hole of the disc, clamp on the bead seat close to the disc.

TO SECURE WHEELS WITH ALLOY RIMS ADDITIONAL PROTECTIVE JAWS ARE AVAILABLE. THEY ALLOW YOU TO WORK ON THE RIMS WITHOUT DAMAGING THEM. THE PROTECTIVE JAWS ARE FITTED ONTO THE MANDREL'S NORMAL JAWS BY MEANS OF A BAYONET CONNECTION.

To clamp the wheel proceed as follows:

- Move the tool holder arm (**Fig. 22 ref. 1**) to “out of work” position, manually or with the help of the provided controls, according to the model of tyre changing machine which is being used;
- Place the wheel vertical on the machine table;
- Translate the mandrel carriage towards the tyre until the self-centring arms are inserted inside the rim;
- Adjust self-centring chuck opening to suit the type of rim to be clamped by means of the “open/close” control (**Fig. 15 ref. E/F and Fig. 17 ref. I/L**);
- Use lever (**Fig. 15 ref. A and Fig. 17 ref. 1**) to position the coaxial mandrel with the wheel centre, in order to make the jaws edges skim the wheel edge;
- Operate the control (**Fig. 15 ref. E and Fig. 17 ref. I**) until the wheel is completely clamped;
- Make sure the rim is always correctly locked and centred, and the wheel is lifted from the machine platform, in order to prevent the rim from slipping in the following operations.



KEEP ON OPERATING RIM CLAMPING CONTROL, UNTIL REACHING THE MAXIMUM OPERATING PRESSURE (160 ÷ 180 BAR), WHICH CAN BE CHECKED THROUGH THE PRE-ARRANGED PRESSURE GAUGE.

DURING ALL TYRES MOUNTING AND DEMOUNTING OPERATIONS, THE SELF-CENTRING CHUCK ROTATION SPEED CAN BE DOUBLED BY ROTATING THE SELECTOR (FIG. 14 REF. C1).

IN CASE OF G9256D.15, G9256TD.15, G9256.11SL (VARGNAV43AD), G9256.15SL (MODEL WITH INVERTER VERSION) (VARGNAV43AD) G10360D.15 AND G10360TD.15 MODELS, USING THE SELECTOR (FIG. 14 REF. C2), SELF-CENTRING CHUCK ROTATION SPEED CAN BE ADJUSTED RESPECTIVELY AT 1, 6 OR 12 RPM. LOW SPEED IS RECOMMENDED FOR WHEELS WITH GREAT DIAMETER AND WEIGHT. 1 RPM IS THE CORRECT SPEED VALUE FOR THE GROOVE OF TRUCK TYRES. LUBRICATE THE TYRE BEADS CAREFULLY TO PROTECT THEM AGAINST ANY DAMAGE AND SIMPLIFY MOUNTING AND DEMOUNTING OPERATIONS.

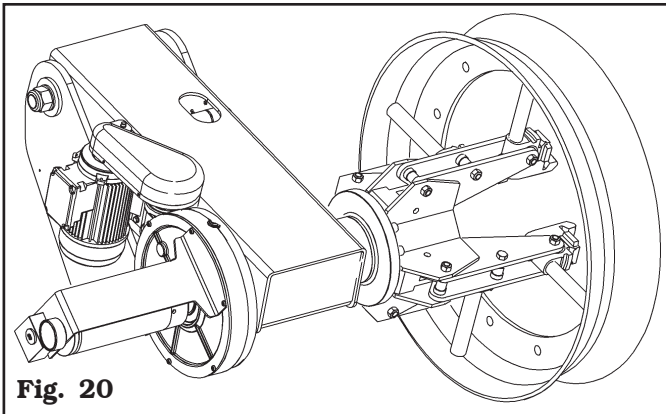


Fig. 20

Locking with extensions

Whenever the rim exceeds the 42" in the locking point, use the appropriate extensions supplied with the tyre-changer. To avoid damages or scratches on light alloy rims, the special jaws supplied with the tyre changer as an optional should be used.



AFTER COMPLETION OF TYRE MOUNT/DEMOUNT OPERATIONS DO NOT LEAVE THE WHEEL CLAMPED ON THE SELF-CENTRING CHUCK AND NEVER LEAVE IT UNATTENDED ANYWAY.

DURING ALL TYRES MOUNTING AND DEMOUNTING OPERATIONS, THE SELF-CENTRING CHUCK ROTATION SPEED CAN BE DOUBLED BY ROTATING THE SELECTOR (FIG. 14 REF. C1).

IN CASE OF G9256D.15, G9256TD.15, G9256.11SL (VARGNAV43AD), G9256.15SL (MODEL WITH INVERTER VERSION) (VARGNAV43AD) G10360D.15 AND G10360TD.15 MODELS, USING THE SELECTOR (FIG. 14 REF. C2), SELF-CENTRING CHUCK ROTATION SPEED CAN BE ADJUSTED RESPECTIVELY AT 1, 6 OR 12 RPM. LOW SPEED IS RECOMMENDED FOR WHEELS WITH GREAT DIAMETER AND WEIGHT. 1 RPM IS THE CORRECT SPEED VALUE FOR THE GROOVE OF TRUCK TYRES. LUBRICATE THE TYRE BEADS CAREFULLY TO PROTECT THEM AGAINST ANY DAMAGE AND SIMPLIFY MOUNTING AND DEMOUNTING OPERATIONS.

12.5 Functioning of tool holder arm

During the working phases, the tool holder arm can maintain two firm positions, that is:

- 1) "Working" position;
- 2) "Out of work" position.

In "working" position (**Fig. 21 ref. 1**) the tool holder arm is lowered towards the mandrel and from this position it executes the various tyre bead breaking, demounting and mounting operations.

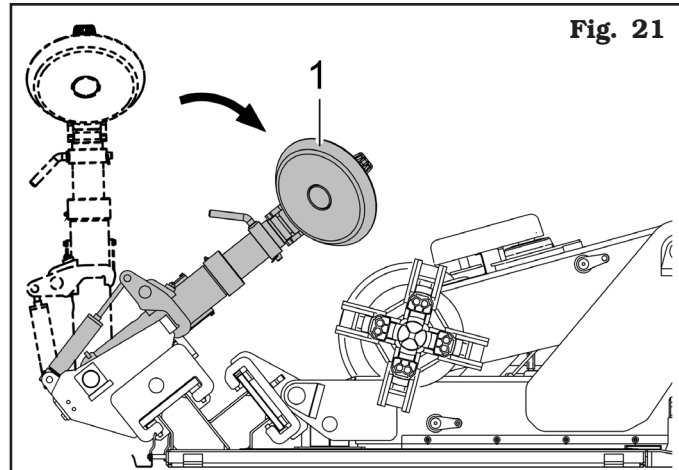


Fig. 21

In "out of work" position (**Fig. 22 ref. 1**) the tool holder arm is in vertical position and has to be brought in this position every time it is not in use and in order to be shifted from one tyre side to another, during the different working phases.

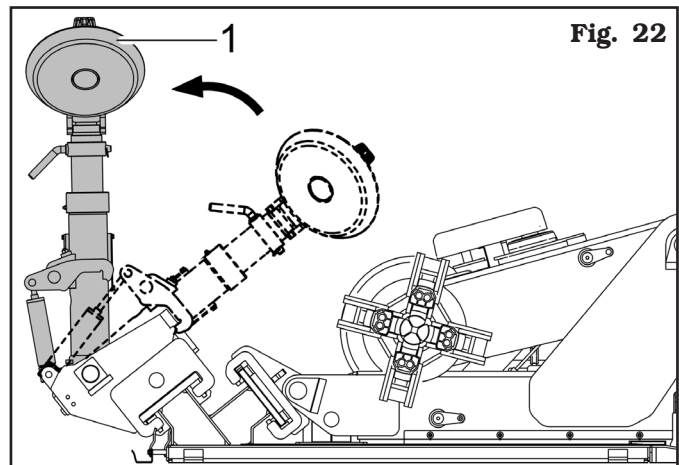


Fig. 22

The tool holder arm moves from "out of work" position to "working position" manually or through hydraulic cylinder.



IN WORKING POSITION, THE SAFETY JACKS (FIG. 1, 2, 3, 4, 5, 6 AND 7 REF. 8) MUST BE HOOKED TO THE TOOL CARRIAGE (FIG. 1, 2, 3, 4, 5, 6 AND 7 REF. 13).

On the contrary, in order to reach "out of work" position from "working position", the tool holder arm moves through the manipulator control operating the cylinder (**Fig. 1, 3, 4, 5, 6 and 7 ref. 21**) in case of **G9256.11SL, G9256.15, G9256T.15, G9256A.15, G9256D.15, G9256TD.15, G9256.15SL** or **G10360.15, G10360T.15, G10360A.15, G10360D.15, G10360TD.15**, or it moves after the provided pedal (**Fig. 2 ref. 21**) is pushed, in case of **G9256.11ST**.

The tool holder arm moves from "out of work" position to "working position" manually or through hydraulic cylinder.

12.5.1 Tools rotation

**G9256.15, G9256T.15, G9256A.15, G9256D.15,
G9256TD.15, G10360.15, G10360T.15,
G10360A.15, G10360D.15, G10360TD.15**

The 180° rotation of the tool holder head is carried out automatically through manipulator control (Fig. 15 ref. C and D and Fig. 17 ref. M and N).

12.5.2 Tools unit extraction/insertion

**G9256.15, G9256T.15, G9256A.15, G9256D.15,
G9256TD.15, G10360.15, G10360T.15,
G10360A.15, G10360D.15, G10360TD.15**

The tools holder head has two working positions.

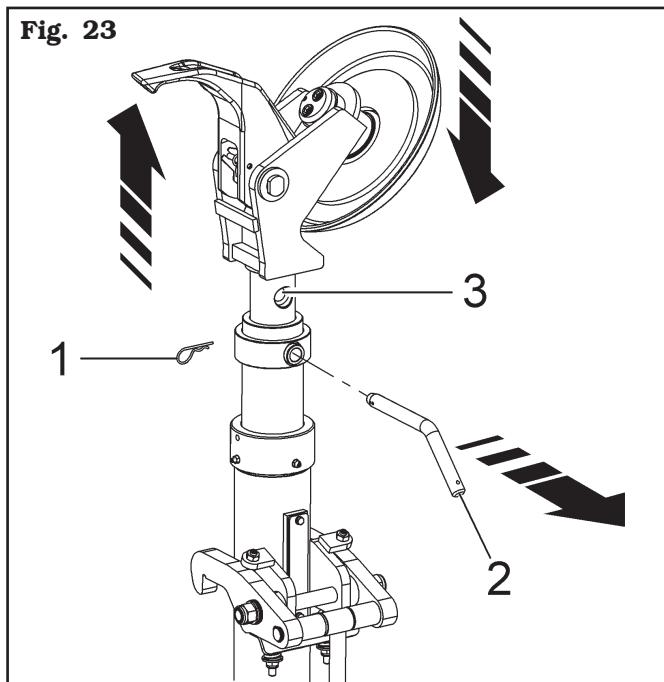
N.B.: the following operations must be carried out with the tools head in "out of work" position.

To shift from a position to another one, just remove the safety split pin (Fig. 23 ref. 1) and manually extract the lever (Fig. 23 ref. 2). Manually lift or lower the tools holder head until the locking holes match (Fig. 23 ref. 3).



WHEN THE TOOL HOLDER HEAD IS LOWERED, MOVE THE HEAD ITSELF DOWNWARDS WITH THE FREE HAND.

When the new position has been reached, insert the lever again (Fig. 23 ref. 2) in the provided hole and assemble the safety split pin again (Fig. 23 ref. 1).

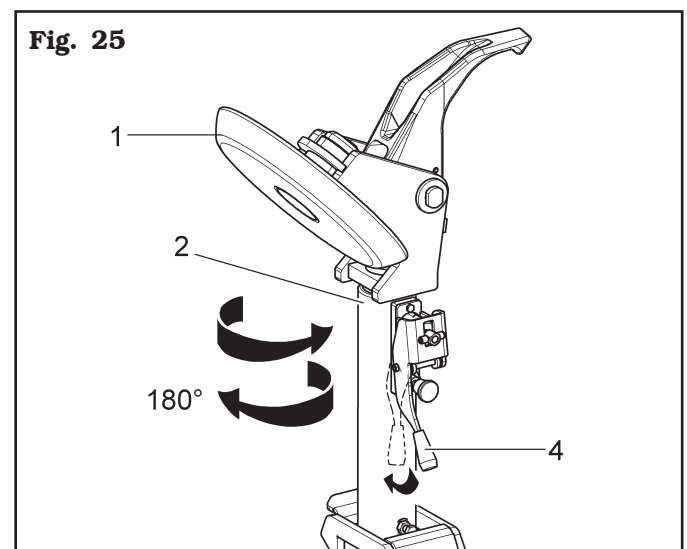
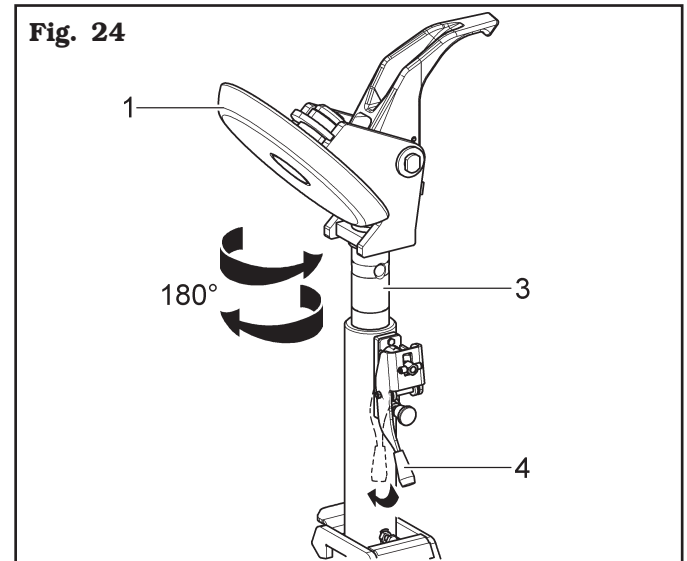


12.5.3 Quick-fit device (G9256.11SL, G9256.11ST and G9256.15SL)

The machine, equipped with a quick-fit tool, remarkably facilitates the tools unit extraction/rotation operations. Here follows the description of these operations:

TOOL ROTATION

To rotate the tool head (Fig. 24 - 25 ref. 1) (both in low (Fig. 25 ref. 2) and high position (Fig. 24 ref. 3)) just push the unlocking lever (Fig. 24 - 25 ref. 4) towards the tool arm. When the head new working position is reached (Fig. 24 - 25 ref. 1) lever (Fig. 24 - 25 ref. 4) automatically inserts locking its rotation.



TOOL EXTRACTION

N.B.: the following operations must be carried out with the tools head in "out of work" position.

1) Push the lever towards the tool arm (Fig. 26 ref. 1) and place the head (Fig. 26 ref. 2) at 90° compared to the work position.

- 2) Lift the head manually until the pin (**Fig. 27 ref. 3**) fits automatically.
- 3) Now the head (**Fig. 27 ref. 2**) stays up, allowing easily the rotation operations described before.

Fig. 26

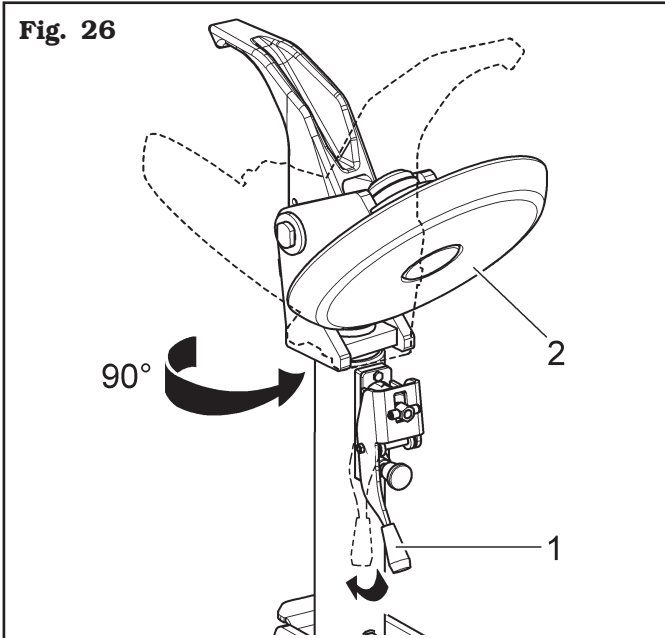
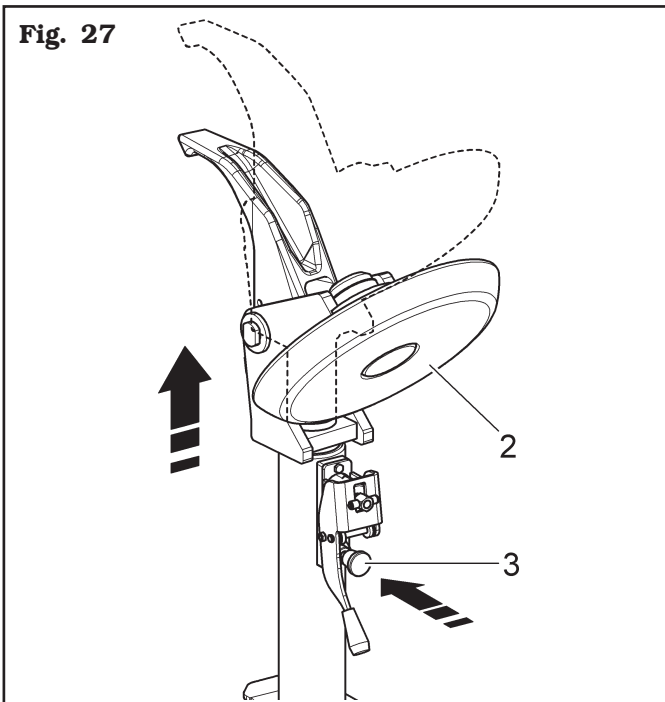


Fig. 27



TOOL INTRODUCTION

- 1) Push the lever towards the tool arm (**Fig. 28 ref. 1**) and place the head (**Fig. 28 ref. 2**) at 90° compared to the work position.
- 2) Pulling the check pin outwards (**Fig. 29 ref. 3**) the head (**Fig. 29 ref. 2**) inserts in its seat.



DURING THIS OPERATION, WITH THE HAND LEFT FREE, MOVE THE HEAD (FIG. 29 REF. 2) DOWNWARDS.

- 3) At this point, it is possible to rotate the head (**Fig. 29 ref. 2**) as described before.



PAY ATTENTION NOT TO SQUASH THE HANDS BETWEEN THE TOOL SUPPORT AND THE ARM!

Fig. 28

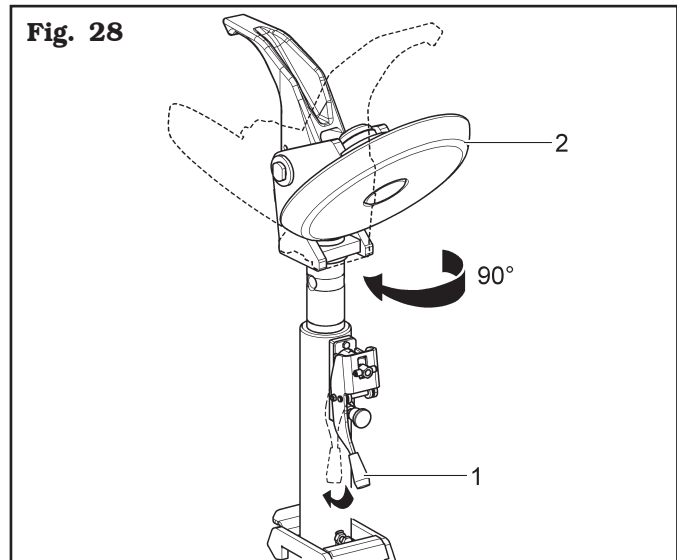
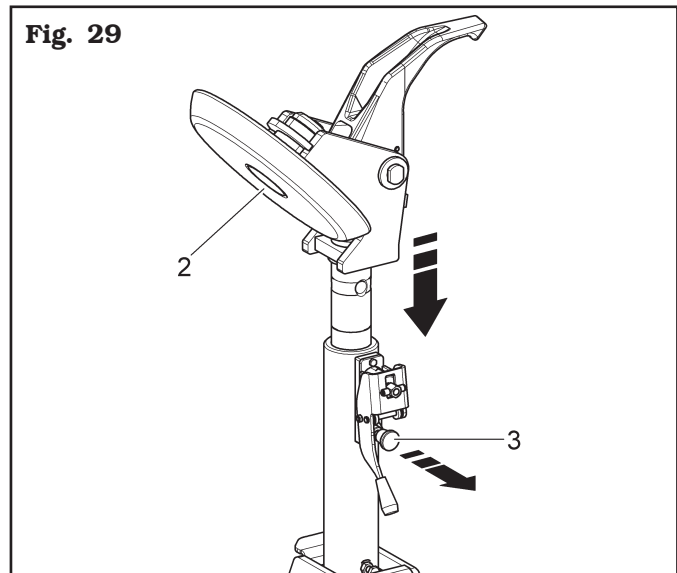


Fig. 29



12.6 Tubeless tyres

12.6.1 Bead breaking



NEVER PLACE ANY PART OF YOUR BODY BETWEEN THE TOOL UNIT AND THE TYRE.



THROUGHOUT TYRE MOUNTING/DEMOUNTING OPERATIONS, CHECK THAT THE SELF-CENTRING CHUCK CLAMPING PRESSURE IS CLOSE TO THE MAXIMUM OPERATING VALUE (160 - 180 BAR).

- A.** Lock the wheel on the mandrel as described in the previous paragraph.
- B.** Remove all balancing weights from the rim. Extract the valve and let air out of tyre.
- C.** Move to work position **C** (**Fig. 12**).
- D.** Lower tool holder arm into work position (hooked safety jack) (**Fig. 21**).
- E.** Place as shown in **Fig. 30** the beading disc (**Fig. 30 ref. 1**) by means of the relevant handle control; the outer profile of the rim (**Fig. 30 ref. 2**) must almost touch the beading disc.



ALWAYS MAKE SURE THAT THE ARM IS CORRECTLY HOOKED TO CARRIAGE.

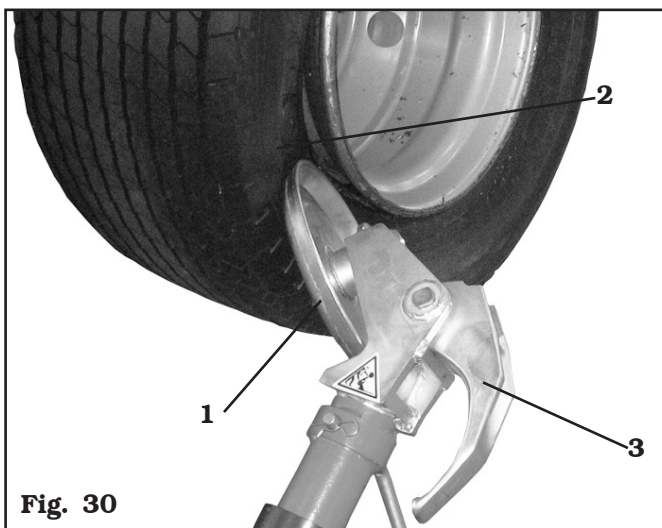


Fig. 30



THE BEADING DISC MUST NOT EXERT PRESSURE ON THE RIM BUT ON THE TYRE BEAD.

- F.** Turn the mandrel counterclockwise and, at the same time, gradually move the tool carrier inwards to bead the tyre. Continue to turn the mandrel while generously lubricating the tyre rim and bead with a suitable lubricant. To avoid risks, lubricate the beads by turning clockwise if you are working on the outer side or counterclockwise if you are working on the inner side. The more the wheel adheres to the rim, the slower should the beading disc advance.



USE ONLY TYRE LUBRICANTS. SUITABLE LUBRICANTS CONTAIN NO WATER, HYDROCARBONS, OR SILICONE.

- G.** Once external beading has been carried out, unhook and lift the tool holder arm placing it in "off-work" position (**Fig. 22 ref. 1**); use the handle control to position the tool holder arm on the inner side of the wheel, then place it in "work position" (**Fig. 21 ref. 1**) and secure it with the special safety jack.



PAY ATTENTION WHEN REPOSITIONING THE TOOL HOLDER ARM TO AVOID CRUSHING HANDS.

- H.** Carry out the tools holder head 180° rotation according to the descriptions of the relevant paragraph, so that the beading disc (**Fig. 31 ref. 1**) is placed against the rim edge (**Fig. 31 ref. 2**).
- I.** Move to work position **D** (**Fig. 12**) and repeat the operations described in points **E**, **F** until the tyre has been completely beaded.

During all beading operations it is advisable to bend the hook tool (**Fig. 30-31 ref. 3**) to avoid obstacles during the operating phases.

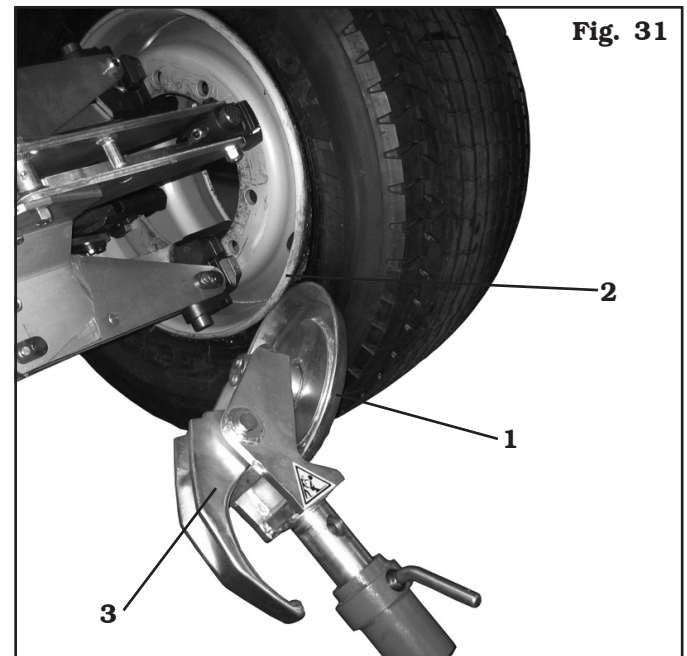


Fig. 31

12.6.2 Demounting



THROUGHOUT TYRE MOUNTING/DEMOUNTING OPERATIONS, CHECK THAT THE SELF-CENTRING CHUCK CLAMPING PRESSURE IS CLOSE TO THE MAXIMUM OPERATING VALUE (160 - 180 BAR).

Tubeless tyres can be removed in two ways:

A. If the wheel does not present particular problems, continuing beading operation will completely dislodge the beads from the rim. The inner bead, pushed by the disc, presses against the outer one till it has been completely removed (see **Figure 32**).



Fig. 32

B. If the wheel is especially hard, it is not possible to carry out the procedure described in point **A**. A different procedure will be necessary: use the hook tool and follow this sequence of operations:

• Move to work position **C** (**Fig. 12**).

Only for G9256.11SL - G9256.11ST - G9256.15 - G9256A.15 - G9256D.15 - G9256.15SL - G10360.15 - G10360A.15 - G10360D.15 versions

• Position the tool holder arm on the outer side of the wheel and bring forward the hook tool, inserting it between rim and bead until it is secured to the bead itself (see **Fig. 33**).



Fig. 33

- Move the rim away from the tool by about 4-5 cm to avoid possible unhooking of the bead from the same tool.
- Move to work position **A** (**Fig. 12**).
- Translate the tool outwards (**Fig. 34 ref. 2**) to allow easy insertion of lever (**Fig. 34 ref. 1**) between the rim and the bead; insert lever (**Fig. 34 ref. 1**) between rim and bead on the right-hand side of the tool (**Fig. 34 ref. 2**).

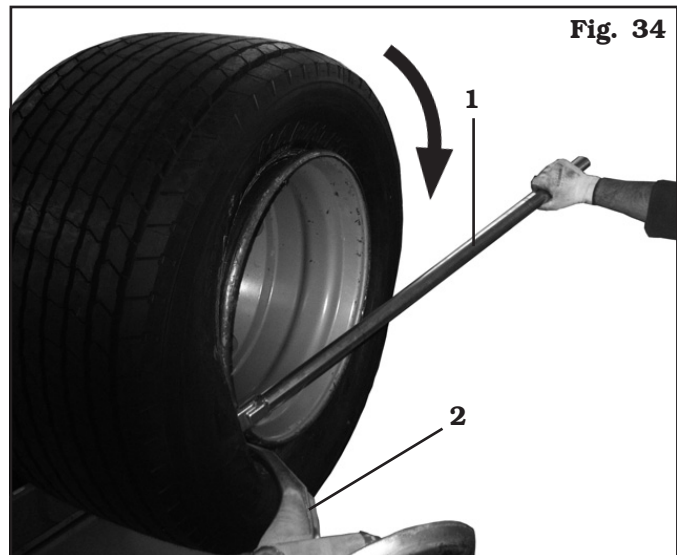


Fig. 34

- Keeping the lever pressed, lower the wheel until the edge of the rim is 5 mm distant from the hook tool.
- Turn the wheel clockwise keeping lever pressed (**Fig. 34 ref. 1**) until the bead has gone completely out.

Only for G9256T.15 - G9256TD.15 - G10360T.15 - G10360TD.15 versions



BEFORE STARTING DEMOUNTING THE 1ST BEAD THE SPRING LOCKING DEVICE OF THE TOOL MUST BE EXTRACTED OUTWARDS (FIG. 35 REF. 1).

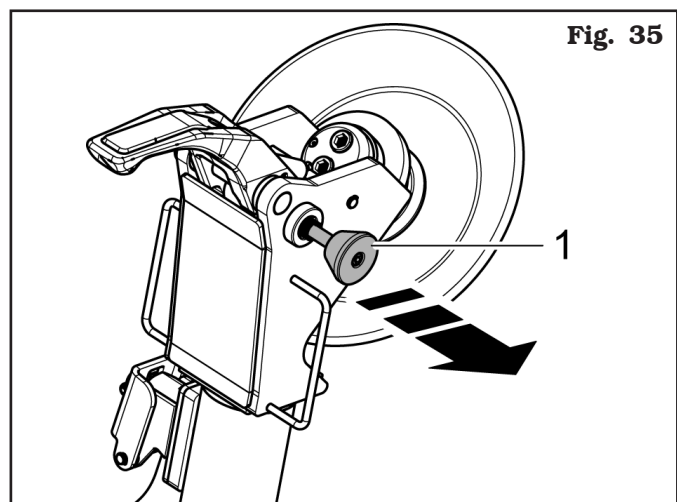
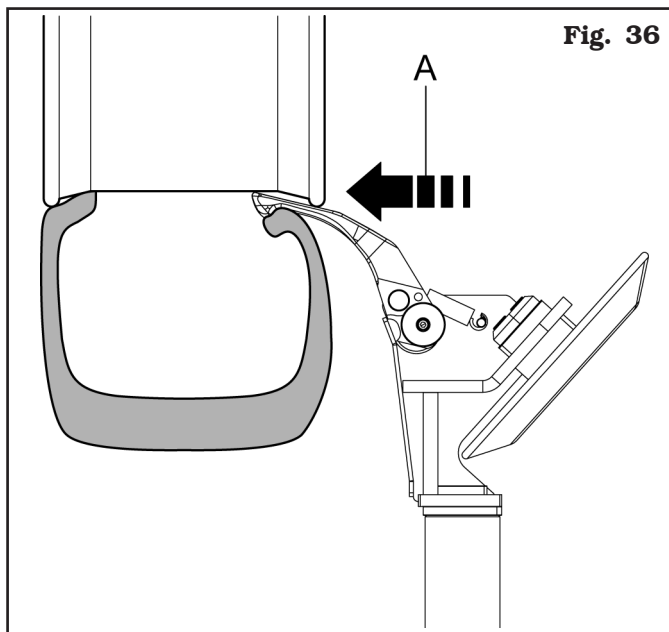
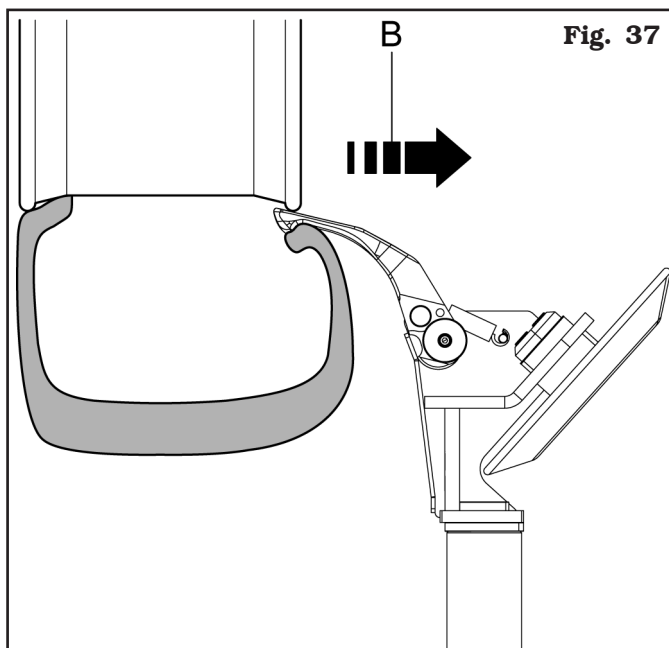


Fig. 35

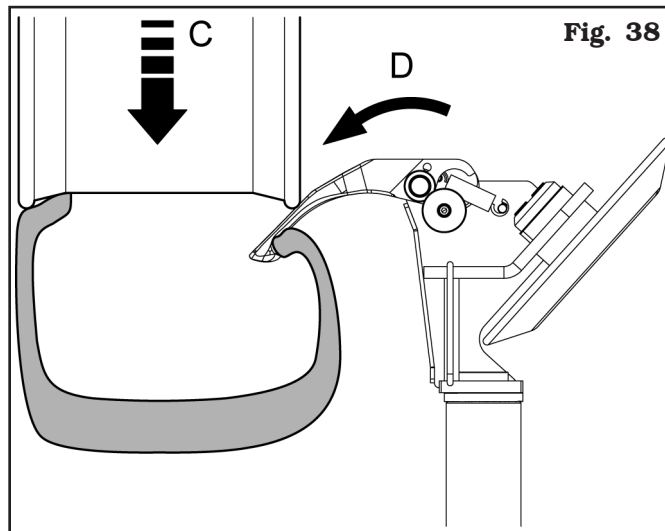
- Position the tool holder arm on the outer side of the wheel and bring forward the hook tool, inserting it between rim and bead until it is secured to the bead itself (see **Fig. 36 ref. A**).



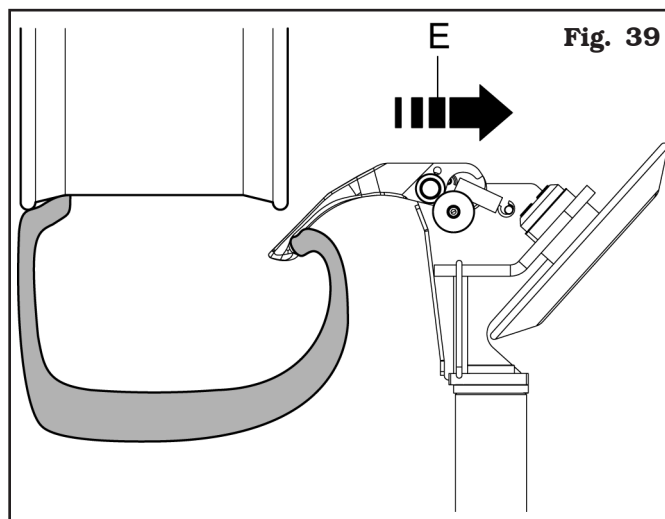
- Translate the tool outwards (**Fig. 37 ref. B**) until the first bead is brought outside the rim.



- Lower the mandrel (**Fig. 38 ref. C**) until locking the tool in the extraction position (**Fig. 38 ref. D**).



- Translate the tool outwards (**Fig. 39 ref. E**) until the bead is brought to mounting position.



- Then rotate the wheel clockwise until the first bead has completely gone out.

For all versions

- Once the external bead has been removed, move tool holder arm away from the wheel, unhook it and lift it bringing it in "out of work" position (**Fig. 22 ref. 1**); use the handle control to position the tool holder arm on the inner side of the wheel then place it in "working" position again (**Fig. 21 ref. 1**) and secure with the safety hook provided.



PAY ATTENTION WHEN REPOSITIONING THE TOOL HOLDER ARM TO AVOID CRUSHING HANDS.



ALWAYS MAKE SURE THAT THE ARM IS CORRECTLY HOOKED TO CARRIAGE.

- Move to work position **D** (Fig. 12).
- Carry out the tools holder head 180° rotation in order to insert the hook tool (Fig. 40 ref. 1) between rim edge and tyre bead.

Fig. 40



- Move the rim away from the tool by about 4-5 cm to avoid possible unhooking of the bead from the same tool.
- Move to work position **B** (Fig. 12).
- Translate the hook tool outwards to allow easy insertion of the lever between the rim and the bead on the tool left. Keeping the lever pressed, lower the wheel until the edge of the rim is 5 mm distant from the hook tool then turn the mandrel counterclockwise until the tyre has been completely removed.



THE REMOVAL OF THE BEADS FROM THE RIM CAUSES THE TYRE TO FALL. ALWAYS MAKE SURE THAT NO ONE IS STANDING BY ACCIDENT IN THE WORK AREA.

12.6.3 Mounting



WHEN DEMOUNTING VERY HEAVY TYRES, IT IS IMPORTANT TO MOVE THE WHEEL AS CLOSE AS POSSIBLE TO THE BASE BEFORE COMPLETING THE OPERATION.



THROUGHOUT TYRE MOUNTING/DEMOUNTING OPERATIONS, CHECK THAT THE SELF-CENTRING CHUCK CLAMPING PRESSURE IS CLOSE TO THE MAXIMUM OPERATING VALUE (160 - 180 BAR).

Tubeless tyre fitting is normally done with the disc tool; if the wheel is especially hard to fit, use the hook tool.

With beading disc

Proceed as follows:

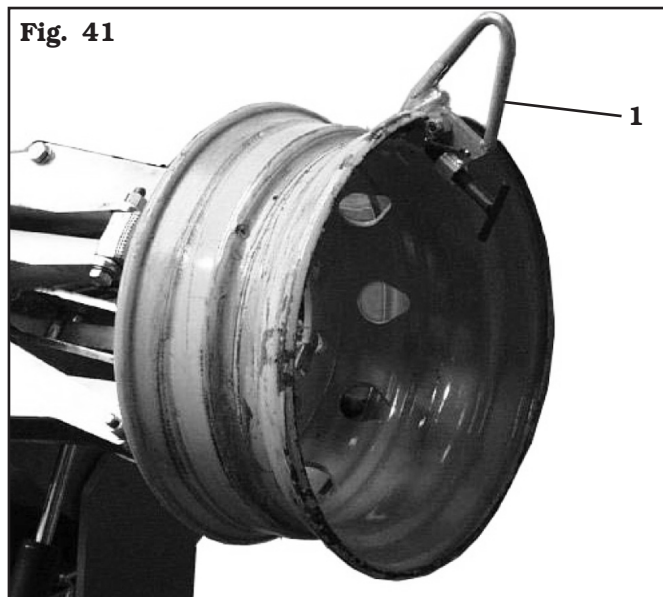
- Secure the rim to the mandrel according to the procedure described in paragraph "WHEEL CLAMPING".
- Adequately lubricate the tyre beads and the rim bead seat with a suitable lubricant using the provided brush.



USE ONLY TYRE LUBRICANTS. SUITABLE LUBRICANTS CONTAIN NO WATER, HYDROCARBONS, OR SILICONE.

- Mount grippers (Fig. 41 ref. 1) on the external edge of the rim in the highest point as shown in Fig. 41.

Fig. 41

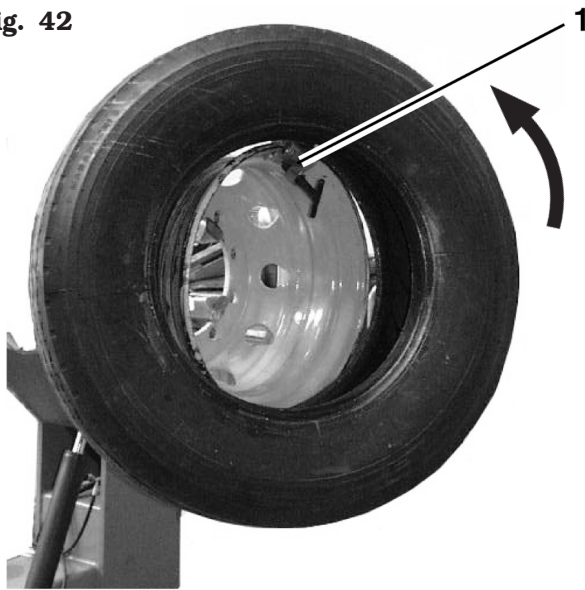




THE GRIPPERS MUST BE TIGHTLY SECURED TO THE EDGE OF THE RIM.

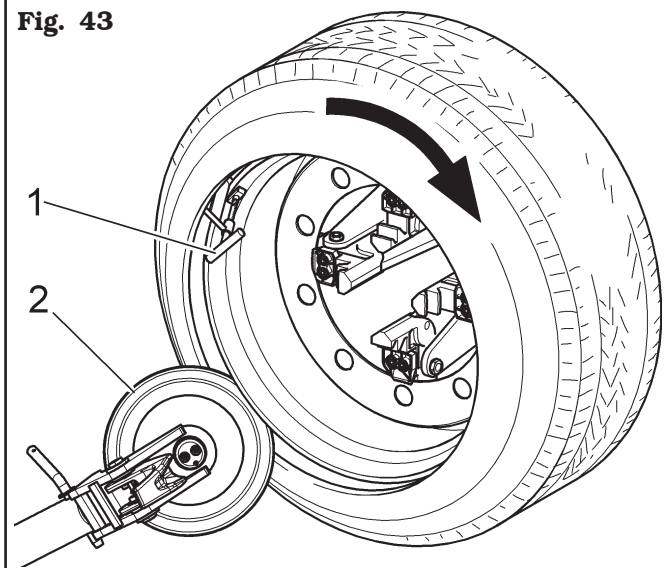
- Move to work position **B** (Fig. 12).
- Lower the mandrel arm completely. Roll the tyre on the platform and hook it to clamp (Fig. 42 ref. 1).
- Lift the mandrel arm with the tyre hooked and turn it counterclockwise by about 15-20 cm; the tyre will position itself sideways with respect to the rim (Fig. 42).

Fig. 42



- Move to work position **C** (Fig. 12).
- Position beading disc (Fig. 43 ref. 2) so that it is at approximately 1.5 cm (1/2") from the edge of the rim. The fitting clamp (Fig. 43 ref. 1) is at 11 o'clock. Turn the mandrel until the grippers reach the lowest point (6 o'clock).

Fig. 43



- Move the beading disc away from the wheel.
- Remove the grippers and fit them in the same position (6 o'clock) outside the second bead.
- Turn the mandrel 90° clockwise until the grippers are at 9 o'clock.
- Move the beading disc forward until it is inside the edge of the rim by about 1-2 cm, making sure it is approximately 5 mm from the profile. Begin clockwise rotation making sure that, after a 90° turn, the second bead begins to slide in the rim groove.
- Once insertion is completed, move the tool away from the wheel, turn it over into "out of work" position and remove the grippers.
- Lower the mandrel until the wheel rests on the footboard.
- Move to work position **A** (Fig. 12).
- Close the mandrel jaws completely, making sure the wheel is held up to avoid dropping.



MAKE SURE THAT THE WHEEL'S HOLD IS SECURE TO AVOID IT FALLING DURING REMOVAL. FOR HEAVY AND/OR VERY LARGE WHEELS USE AN ADEQUATE LIFTING DEVICE.

- Translate the platform to release the wheel from the mandrel. With especially soft tyres, simultaneously insert both beads on the jaw so that bead insertion in the tyre is done only once; this single operation is ideal for saving time.

With hook tool

Proceed as follows:

- Secure the rim to the mandrel according to the procedure described in paragraph "WHEEL CLAMPING".
- Adequately lubricate the tyre beads and the rim bead seat with a suitable lubricant using the provided brush.



USE ONLY TYRE LUBRICANTS. SUITABLE LUBRICANTS CONTAIN NO WATER, HYDROCARBONS, OR SILICONE.

- Mount grippers (Fig. 41 Ref. 1) on the external edge of the rim in the highest point.



THE GRIPPERS MUST BE TIGHTLY SECURED TO THE EDGE OF THE RIM.

- Move to work position **B (Fig. 12)**.
- Lower the mandrel arm completely. Roll the tyre on the platform and hook it to clamp (**Fig. 42 ref. 1**).
- Lift the mandrel arm with the tyre hooked and turn it counterclockwise by about 15-20 cm; the tyre will position itself sideways with respect to the rim (**Fig. 42**).
- Place the tool holder arm in “off-work” position (**Fig. 22 ref. 1**); translate it to the inner side of the tyre and hook it again into “work position” (**Fig. 21 ref. 1**).
- Carry out the tools head 180° rotation until the hook tool is moved onto the tyre side (see **Fig. 44**).

Fig. 44



- Move to work position **D (Fig. 12)**.
- Move the tool forward until the reference notch matches the external edge of the rim coincide at about 5 mm from the rim itself.
- Move to work position **C (Fig. 12)**.
- From the external side of the wheel, check the exact position of the tool and, if necessary, correct it. Then, turn the mandrel clockwise until the grippers reach the lowest point (6 o'clock). The first bead should now be inserted in the rim.
- Remove the grippers.
- Move to work position **D (Fig. 12)**.
- Extract the tool from the tyre.
- Place the tool holder arm in “off-work” position (**Fig. 22 ref. 1**); translate it to the outer side of the tyre and hook it again into “work position” (**Fig. 21 ref. 1**).
- Carry out the tools head 180° rotation until the hook tool is moved onto the tyre side (see **Fig. 33**).

- Mount the grippers in the lowest point (6 o'clock) outside the second bead.
- Move to work position **C (Fig. 12)**.
- Turn the mandrel 90° clockwise until the grippers are at 9 o'clock.
- Move the tool forward until the axis of the reference notch matches that of the external edge of the rim at about 5 mm from the rim itself (**Fig. 33**). Begin clockwise rotation making sure that, after a 90° turn, the second bead begins to slide in the rim groove. Turn until the grippers reach the lowest point (6 o'clock). The second bead should now be inserted in the rim.
- Move the tool away from the wheel, turn it over into “out of work” position and remove the grippers.
- Lower the mandrel until the wheel rests on the footboard.
- Move to work position **A (Fig. 12)**.
- Close the mandrel jaws completely, making sure the wheel is held up to avoid dropping.



MAKE SURE THAT THE WHEEL'S HOLD IS SECURE TO AVOID IT FALLING DURING REMOVAL. FOR HEAVY AND/OR VERY LARGE WHEELS USE AN ADEQUATE LIFTING DEVICE.

12.7 Tyres with inner tube

12.7.1 Bead breaking



REMOVE THE LOCK NUT OF THE INNER TUBE VALVE TO ALLOW ITS EXTRACTION DURING TYRE REMOVAL PHASES; REMOVE THE NUT WHEN DEFLATING THE TYRE.

The beading procedure is the same one described for tubeless tyres.



WHEN BEADING WHEELS WITH INNER TUBES, INTERRUPT THE FORWARD MOVEMENT OF THE BEADING DISC AS SOON AS THE BEADS HAVE BEEN DISLODGED TO AVOID DAMAGE TO THE INNER TUBE OR TO THE VALVE.

12.7.2 Demounting



**THROUGHOUT TYRE MOUNTING/
DEMOUNTING OPERATIONS,
CHECK THAT THE SELF-CEN-
TRING CHUCK CLAMPING PRES-
SURE IS CLOSE TO THE MAXIMUM
OPERATING VALUE (160 - 180
BAR).**

- Tilt up tool holder arm, unhook it and lift it placing it in “off-work” position (**Fig. 22 ref. 1**); use the handle control to position the tool holder arm on the outer side of the wheel then place it in “work position” (**Fig. 21 ref. 1**) and secure with the safety hook provided (**Fig. 1, 2, 3, 4, 5, 6 and 7 ref. 8**).

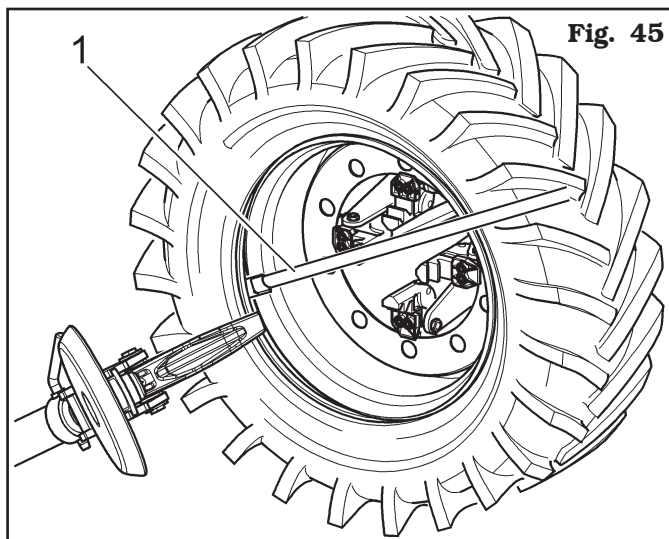


**PAY ATTENTION WHEN REPO-
SITIONING THE TOOL HOLDER ARM
TO AVOID CRUSHING HANDS.**

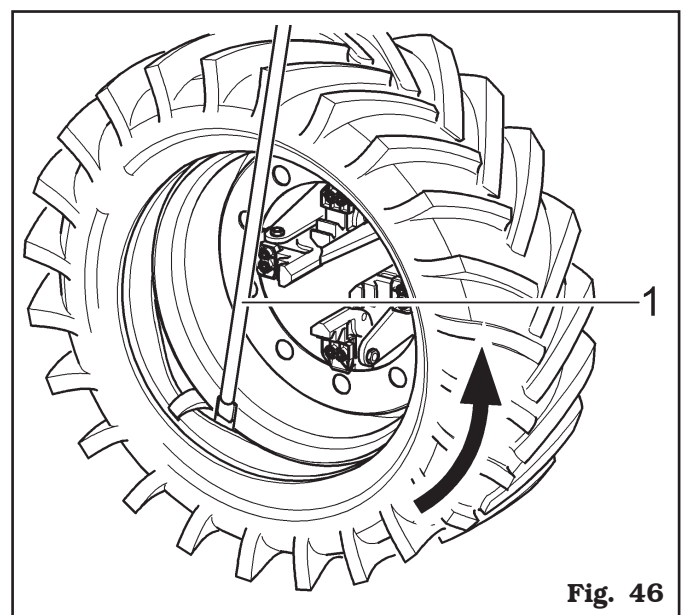


**ALWAYS MAKE SURE THAT THE
ARM IS CORRECTLY HOOKED TO
CARRIAGE.**

- Carry out the tools holder head 180° rotation, according to the descriptions in the relevant paragraph, in order to insert the hook between the rim edge and the tyre bead; the operation must be carried out during mandrel rotation.
- Move the rim away from the tool by about 4-5 cm to avoid possible unhooking of the bead from the same tool.
- Translate the hook tool outwards until the reference notch matches the external edge of the rim.
- Move to work position **A** (**Fig. 12**).
- Insert lever (**Fig. 45 ref. 1**) between the rim and the bead on the right-hand side of the tool.



- Keeping the lever pressed, lower the wheel until the edge of the rim is approximately 5 mm distant from the hook tool.
- Turn the wheel clockwise keeping lever pressed until the bead has gone completely out.
- Move away the tool holder arm in “off-work” position (**Fig. 22 ref. 1**); lower the clamping unit until the tyre rests on the footboard; exert a certain pressure on it so that when the mandrel is moved slightly backwards, this will create enough space to extract the inner tube.
- Extract the inner tube and lift the wheel.
- Move to work position **D** (**Fig. 12**).
- Tilt up tool holder arm, unhook it and lift it placing it in “off-work” position (**Fig. 22 ref. 1**); use the handle control to position the tool holder arm on the inner side of the wheel then place it in “work position” (**Fig. 21 ref. 1**) and secure with the safety hook provided (**Fig. 1, 2, 3, 4, 5, 6 and 7 ref. 8**).
- Carry out the tools holder head 180° rotation, according to the descriptions in the relevant paragraph, in order to insert the hook between the rim edge and the tyre bead; the operation must be carried out during mandrel rotation.
- Move the rim away from the tool by about 4-5 cm to avoid possible unhooking of the bead from the same tool.
- Move to work position **A** (**Fig. 12**).
- Translate the hook tool outwards until the reference notch is 3 cm inside the rim.
- Insert lever (**Fig. 46 ref. 1**) between rim (**Fig. 46 ref. 2**) and head (**Fig. 46 ref. 3**) on tool's right-hand side.



- Keeping the lever pressed, lower the wheel until the edge of the rim is approximately 5 mm distant from the hook tool then turn the mandrel counterclockwise keeping the lever (**Fig. 46 ref. 1**) pressed until the tyre has been completely dislodged from the rim.



THE REMOVAL OF THE BEADS FROM THE RIM CAUSES THE TYRE TO FALL. ALWAYS MAKE SURE THAT NO ONE IS STANDING BY ACCIDENT IN THE WORK AREA.



WHEN DEMOUNTING VERY HEAVY TYRES, IT IS IMPORTANT TO MOVE THE WHEEL AS CLOSE AS POSSIBLE TO THE BASE BEFORE COMPLETING THE OPERATION.

12.7.3 Mounting



THROUGHOUT TYRE MOUNTING/DEMOUNTING OPERATIONS, CHECK THAT THE SELF-CENTRING CHUCK CLAMPING PRESSURE IS CLOSE TO THE MAXIMUM OPERATING VALUE (160 - 180 BAR).

- Secure the rim to the mandrel according to the procedure described in paragraph "WHEEL CLAMPING".
- Adequately lubricate the tyre beads and the rim bead seat with a suitable lubricant using the provided brush.



USE ONLY TYRE LUBRICANTS. SUITABLE LUBRICANTS CONTAIN NO WATER, HYDROCARBONS, OR SILICONE.

- Mount grippers (**Fig. 41 ref. 1**) on the external edge of the rim in the highest point as shown in **Fig. 41**.



THE GRIPPERS MUST BE TIGHTLY SECURED TO THE EDGE OF THE RIM.

- Move to work position **B (Fig. 12)**.
- Position the tyre on the footboard and lower the mandrel (make sure that the grippers are in the highest point) to hook the first tyre bead (internal bead).
- Lift the mandrel arm with the tyre hooked and turn it counterclockwise by about 15-20 cm; the tyre will position itself sideways with respect to the rim.
- Tilt up tool holder arm, unhook it and lift it placing it in "off-work" position (**Fig. 22 ref. 1**); use the handle control to position the tool holder arm on the inner side of the wheel then place it in "work position" (**Fig. 21 ref. 1**) and secure with the safety hook provided.



PAY ATTENTION WHEN REPOSITIONING THE TOOL HOLDER ARM TO AVOID CRUSHING HANDS.



ALWAYS MAKE SURE THAT THE ARM IS CORRECTLY HOOKED TO CARRIAGE.

- Carry out the tools holder head 180° rotation, according to the descriptions in the relevant paragraph, in order to insert the hook between the rim edge and the tyre bead; the operation must be carried out during mandrel rotation.
- Move to work position **D (Fig. 12)**.
- Move the tool forward until the axis of the reference notch matches that of the external edge of the rim at about 5 mm from the rim itself (see **Fig. 47**).

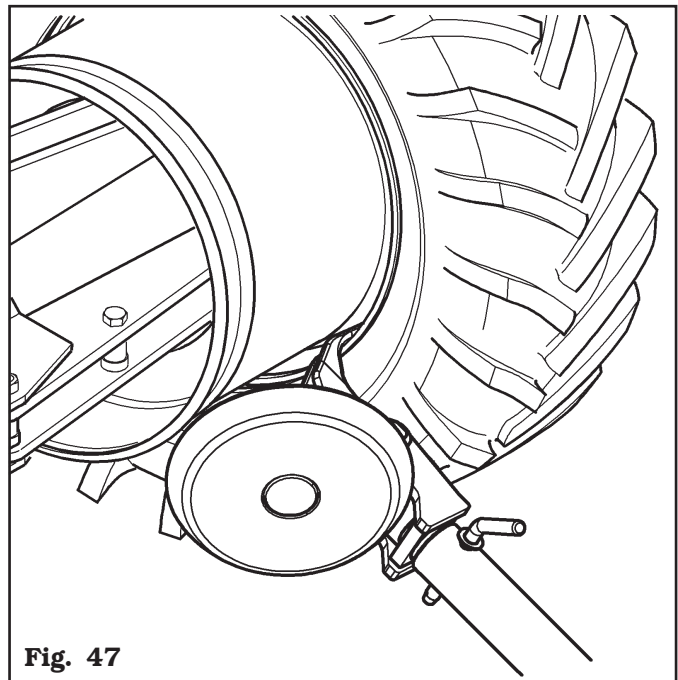


Fig. 47

- Move to work position **C (Fig. 12)**.
- From the external side of the wheel, check the exact position of the tool and, if necessary, correct it. Then, turn the mandrel clockwise until the grippers reach the lowest point (6 o'clock). The first bead should now be inserted in the rim, therefore remove the grippers.

- Move to work position **D** (Fig. 12).
- Extract the tool hook from the tyre.
- Place the tool holder arm in “out of work” position (Fig. 22 ref. 1) and translate it to the outer side of the tyre.
- Carry out the tools holder head 180° rotation, according to the descriptions in the relevant paragraph.
- Move to work position **B** (Fig. 12).
- Turn the mandrel to position the hole to insert the valve downward (6 o'clock).
- Lower the mandrel until the wheel rests on the footboard. Move backward the mandrel to create enough space between the tyre edge and the rim to insert the inner tube.

Note: the valve hole could be in an asymmetric position with respect to the centre of the rim. In this case it is necessary to position and introduce the inner tube as shown in Figure 48.

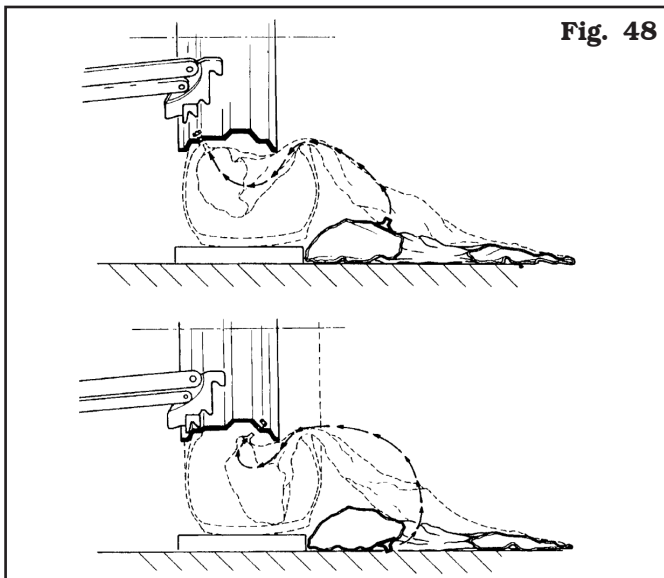
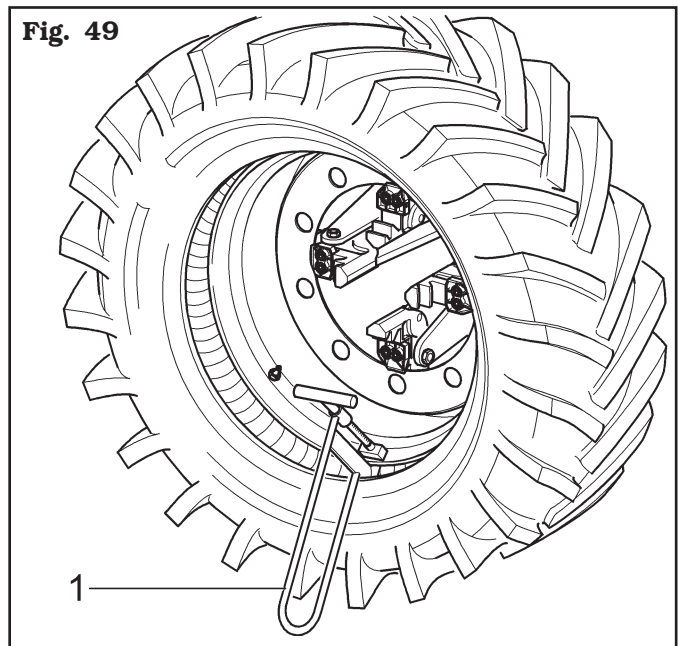


Fig. 48

Introduce the valve in the hole and fix it with the provided ring nut. Introduce the inner tube in the central groove of the rim (to make this operation easier, it is advisable to simultaneously turn the mandrel clockwise).

- Turn the mandrel and position the valve downwards (6 o'clock).
- To avoid damaging the inner tube, slightly inflate it when inserting the second bead.
- To avoid damaging the valve when fitting the second bead, remove the fixing ring nut and mount an extension on the same valve.
- Move to work position **C** (Fig. 12).
- Lift the mandrel and mount the grippers (Fig. 49 ref. 1) on the rim outside the second bead at about 20 cm from the inflating valve on the right.
- Turn the mandrel clockwise until grippers (Fig. 49 ref. 1) are positioned at 9 o'clock.

Fig. 49



- Place the tool holder arm in work position (Fig. 21 ref. 1) on the outer side of the tyre.
- Place the hook tool in work position and bring the tool holder arm forward until the axis of the reference notch matches that of the outer edge of the rim at a distance of 5 mm.
- Turn the mandrel clockwise until lever (Fig. 50 ref. 1) is introduced in the housing obtained on the hook tool.
- Turn the mandrel with lever (Fig. 50 ref. 1) hooked until complete insertion of the tyre outer bead.
- Remove lever (Fig. 50 ref. 1), grippers (Fig. 50 ref. 2) and extract the hook tool by turning the mandrel counterclockwise and translating it outwards.

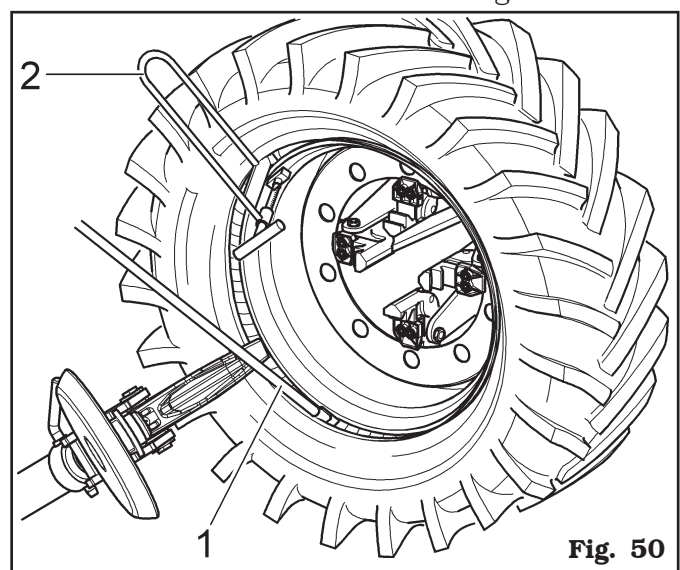


Fig. 50

- Tilt up tool holder arm placing it in “out of work” position (**Fig. 22 ref. 1**) after it has been unhooked.
- Lower the mandrel until the wheel rests on the footboard.
- Move to work position **B** (**Fig. 12**).
- Check the state of the tyre valve and centre it, if necessary, in the rim hole by slightly turning the mandrel; fix the valve with the supplied ring nut after having removed the protective extension.
- Close the mandrel jaws completely, making sure the wheel is held up to avoid dropping.



MAKE SURE THAT THE WHEEL'S HOLD IS SECURE TO AVOID IT FALLING DURING REMOVAL. FOR HEAVY AND/OR VERY LARGE WHEELS USE AN ADEQUATE LIFTING DEVICE.

- Translate the platform to release the wheel from the mandrel.

12.8 Wheels with bead wire

As an example **Fig. 51** and **52** illustrate sections and compositions of types of wheels with bead wire currently being sold.

Fig. 51

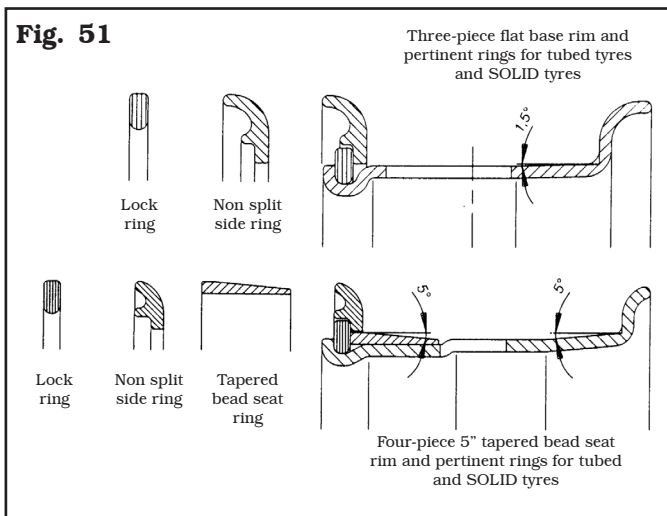
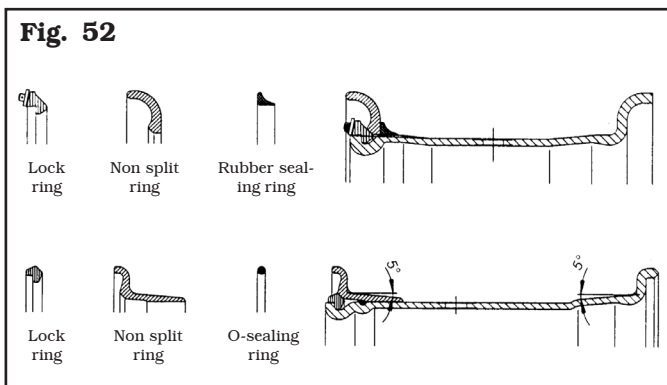


Fig. 52



12.8.1 Beading and demounting



NEVER STAND IN FRONT OF THE WHEEL WHILE THE INFLATION RING IS BEING EXTRACTED FROM THE BEAD WIRE, SINCE IT MAY BE EJECTED VIOLENTLY, CAUSING SERIOUS INJURIES OR WOUNDS.



THROUGHOUT TYRE MOUNTING/DEMOUNTING OPERATIONS, CHECK THAT THE SELF-CENTRING CHUCK CLAMPING PRESSURE IS CLOSE TO THE MAXIMUM OPERATING VALUE (160 - 180 BAR).

- Mount the wheel on the mandrel as described in “WHEEL CLAMPING” and make sure it is deflated.
- Move to work position **D** (**Fig. 12**).
- Place the tool arm in “working position” (**Fig. 21 ref. 1**) in the tyre inner side, and make sure it is locked by the provided safety stop (**Fig. 1, 2, 3, 4, 5, 6 or 7 ref. 8**).
- Position the beading disc on rim edge (see **Fig. 53**).

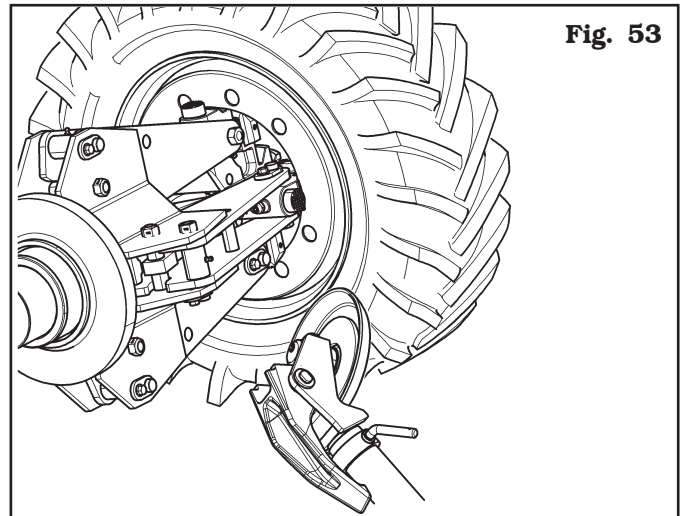
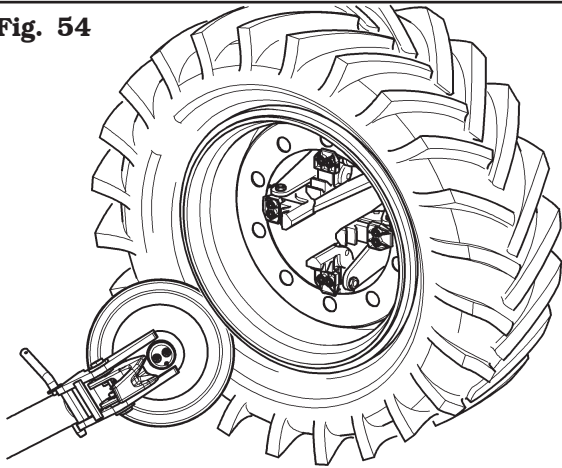


Fig. 53

- Turn the mandrel and smear the entire bead seat of the rim with lubricant. While doing this, jerk the beading disc forward until the first bead is removed (as these wheels feature inner tubes, carry out the operation carefully, paying special attention to when the bead dislodges, trying to stop disc advancement immediately to avoid compromising the integrity of the inner tube and valve).
- Place the tools holder arm in “out of work” position (**Fig. 22 ref. 1**), operate the handle control in order to position the tools holder arm on the wheel outer side, then place it in “working position” (**Fig. 21 ref. 1**) again and lock it with the safety hook provided.

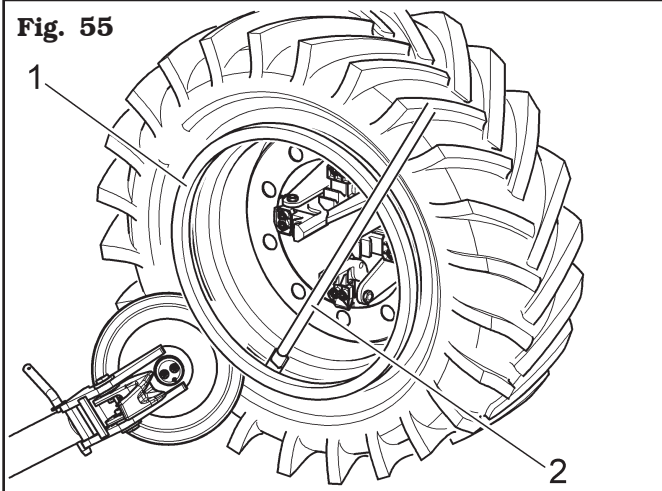
- Carry out the tools holder head 180° rotation according to the description of the relevant paragraph, in order to let the beading disc come into contact with the tyre outer side (see **Fig. 54**).

Fig. 54



- Turn the mandrel and smear the entire bead seat of the rim with lubricant.
- While doing this, jerk the beading disc forward until the first bead is removed;
- Repeat the operation, making the beading disc move forward (see **Fig. 55**) until the stop ring is released (**Fig. 55 ref. 1**). It will be then extracted through lever (**Fig. 55 ref. 2**).

Fig. 55



- Remove the bead wire.
- Remove the O-Ring, when featured.
- Tilt up tool holder arm placing it in “out of work” position (**Fig. 22 ref. 1**) after it has been unhooked.
- Lower the mandrel until the wheel rests on the footboard.
- Move to work position **B** (**Fig. 12**).
- Move backward the mandrel until the tyre is completely dislodged from the rim (in case of tyres with inner tube, make sure that the valve hasn't been damaged during removal).



THE REMOVAL OF THE BEADS FROM THE RIM CAUSES THE TYRE TO FALL. ALWAYS MAKE SURE THAT NO ONE IS STANDING BY ACCIDENT IN THE WORK AREA.



WHEN DEMOUNTING VERY HEAVY TYRES, IT IS IMPORTANT TO MOVE THE WHEEL AS CLOSE AS POSSIBLE TO THE BASE BEFORE COMPLETING THE OPERATION.



PAY ATTENTION WHEN REPOSITIONING THE TOOL HOLDER ARM TO AVOID CRUSHING HANDS.



ALWAYS MAKE SURE THAT THE ARM IS CORRECTLY HOOKED TO CARRIAGE.

12.8.2 Mounting

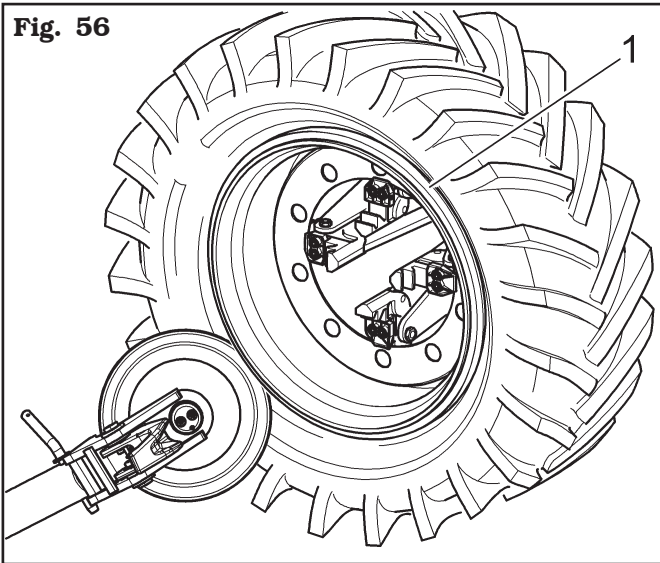


THROUGHOUT TYRE MOUNTING/DEMOUNTING OPERATIONS, CHECK THAT THE SELF-CENTRING CHUCK CLAMPING PRESSURE IS CLOSE TO THE MAXIMUM OPERATING VALUE (160 - 180 BAR).

- Place the tools holder arm in “off-work position” (**Fig. 22 ref. 1**); if it has been removed, fix the rim to the mandrel as described in “WHEEL CLAMPING” paragraph. If the wheel features an inner tube, position the rim with the valve slot facing downwards (at 6 o'clock).
- Lubricate the entire bead seat of the rim and the tyre beads.
- Move to work position **B** (**Fig. 12**).
- Place the mandrel in order to centre the rim on the tyre.
- Operate the mandrel forward translation in order to insert the rim in the tyre (in case of air tube tyres, make the valve re-enter not to damage it). Move forward until the rim is completely inserted in the tyre.
- Insert the bead wire on the rim with the stop ring fitted (if the rim and bead wire feature fixing slits, they must be in phase with each other).
- Move to work position **C** (**Fig. 12**).

- Place the tool holder arm on the external side then lower it into “work position” (**Fig. 21 ref. 1**) with the beading disc facing the wheel. If the outer edge ring is not sufficiently fitted on the rim, position the mandrel until the bead wire is near the beading disc. Move the beading disc forward and then turn the mandrel until the housing of the O-Ring (if featured) is uncovered.
- Lubricated the O-Ring and place it in its housing.
- Move to work position **B** (**Fig. 12**).
- Position the bead wire (**Fig. 56 ref. 1**) on the rim, fit the stop ring with the help of the beading disc as shown in **Fig. 56**.

Fig. 56



- Tilt up tool holder arm placing it in “out of work” position (**Fig. 22 ref. 1**) after it has been unhooked.
- Lower the mandrel until the wheel rests on the footboard.
- Close the mandrel jaws completely and translate the platform outwards until the rim has been completely removed, making sure the wheel is held up to avoid dropping.



CLOSING THE MANDREL CAUSES THE WHEEL TO FALL. ALWAYS MAKE SURE THAT NO ONE IS STANDING BY ACCIDENT IN THE WORK AREA.

13.0 ROUTINE MAINTENANCE



BEFORE CARRYING OUT ANY ROUTINE MAINTENANCE OR ADJUSTMENT PROCEDURE, DISCONNECT THE MACHINE FROM THE ELECTRICITY SUPPLY USING THE SOCKET/PLUG COMBINATION AND CHECK THAT ALL MOBILE PARTS ARE AT A STANDSTILL.



BEFORE EXECUTING ANY MAINTENANCE OPERATION, MAKE SURE THERE ARE NO WHEELS LOCKED ONTO THE MANDREL.



BEFORE REMOVING HYDRAULIC CIRCUIT UNIONS OR PIPES, MAKE SURE THAT THERE ARE NO PRESSURISED FLUIDS PRESENT. PRESSURISED OIL SPILLS MAY CAUSE SERIOUS WOUNDS OR INJURIES.

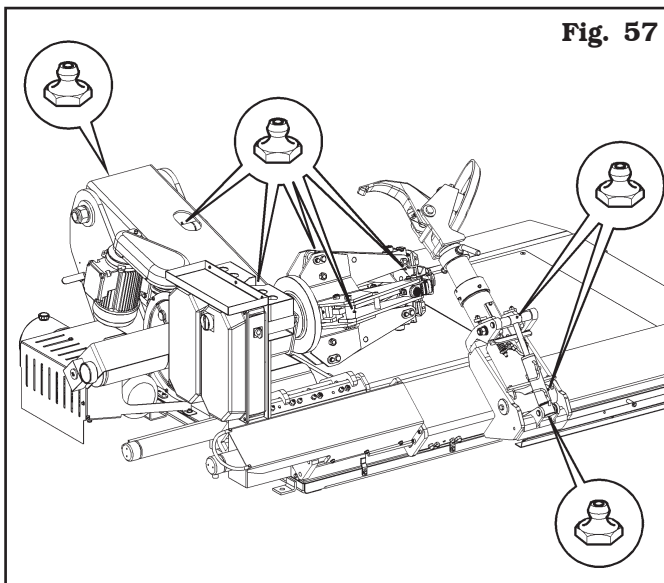


BEFORE CARRYING OUT ANY MAINTENANCE WORK ON THE HYDRAULIC CIRCUIT, SET THE MACHINE IN THE REST CONDITION.

To guarantee the efficiency and correct functioning of the machine, it is essential to carry out daily or weekly cleaning and weekly routine maintenance, as described below

Cleaning and routine maintenance must be conducted by authorized personnel and according to the instructions given below.

- Disconnect the mains power supply before starting any cleaning or routine maintenance operations.
- Remove deposits of tyre powder and other waste materials with a vacuum cleaner.
- **DO NOT BLOW IT WITH COMPRESSED AIR.**
- Periodically (preferably once a month) make a complete check on the controls, ensuring that they provide the specified actions.
- Every 100 working hours lubricate the (tool and mandrel) carriage sliding guides.
- Periodically (preferably once a month), grease all moving parts of the machine (see **Fig. 57**).


Fig. 57

- Check periodically the oil level of the oil-pressure unit and, in case, carry out the filling up with hydraulic oil having a viscosity degree suitable for the average temperatures of the country where the machine is installed and in particular:
 - viscosity 32 (for countries with room temperature from 0 to 30 degrees);
 - viscosity 46 (for countries with room temperature above 30 degrees).

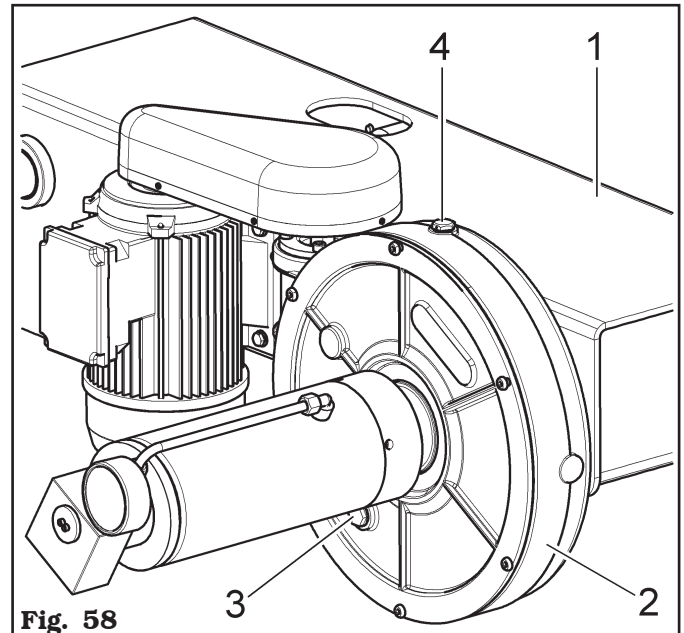
At least once a year it is advisable to proceed anyway to the complete replacement of the hydraulic oil of the hydraulic unit itself.



PERFORM THIS OPERATION ONLY WITH THE MACHINE COMPLETELY CLOSED (HYDRAULIC PISTONS EXTENDED).

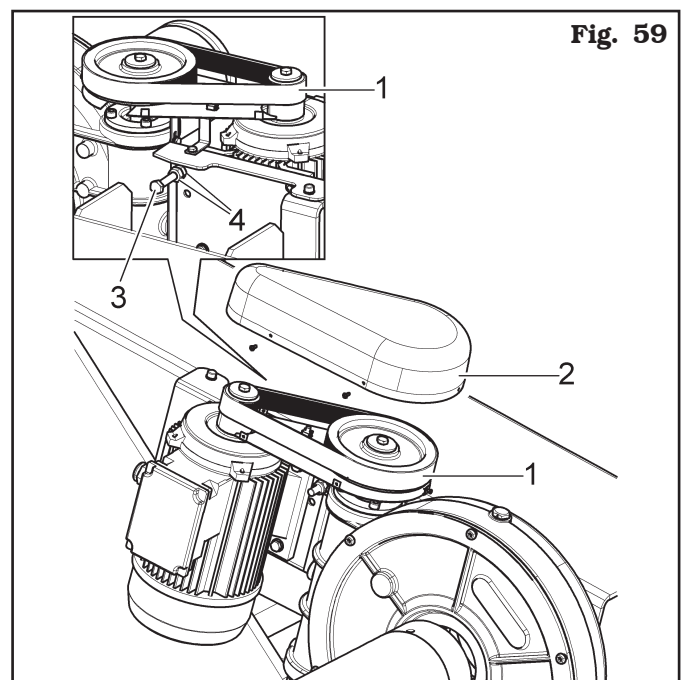
- Periodically (about every 100 hours), check the oil level of the reduction gear and eventually reset the level.
- Check operation of the safety devices every week.

- A.** Place the whole support (**Fig. 58 ref. 1**) in horizontal position, then check the reduction gear oil level (**Fig. 58 ref. 2**); the level indicator window (**Fig. 58 ref. 3**) must be covered with lubricant, otherwise, remove the plug (**Fig. 58 ref. 4**) and top up using appropriate lubricants until the level is reset.


Fig. 58

- B.** Check the belt tensioning (**Fig. 59 ref. 1**):

- Remove the upper guard (**Fig. 59 ref. 2**) with a screwdriver.
- Tension up the belt (**Fig. 59 ref. 1**) turning the screw (**Fig. 59 ref. 3**) after the nuts have been slackened (**Fig. 59 ref. 4**).
- Tighten the fixing nuts (**Fig. 59 ref. 4**) after the adjustment operations, then assemble the protection guard (**Fig. 59 ref. 2**).


Fig. 59

- Periodically (every 50 working hours approximately), carry out the (inner and outer) guides of the tool and mandrel carriages.

OPERATION TO BE CARRIED OUT ONLY IN CASE THAT THE TOOL CARRIAGE AND THE MANDREL CARRIAGE MOVE IN A NON-LINEAR WAY (TRIGGER ACTION).

- C. Check periodically and, if necessary, adjust the play of slides (**Fig. 60 ref. 1**) on the guide plates (**Fig. 60 ref. 2**) by means of the adjustment screws (**Fig. 60 ref. 3**) of the sliding blocks (**Fig. 60 ref. 4**).

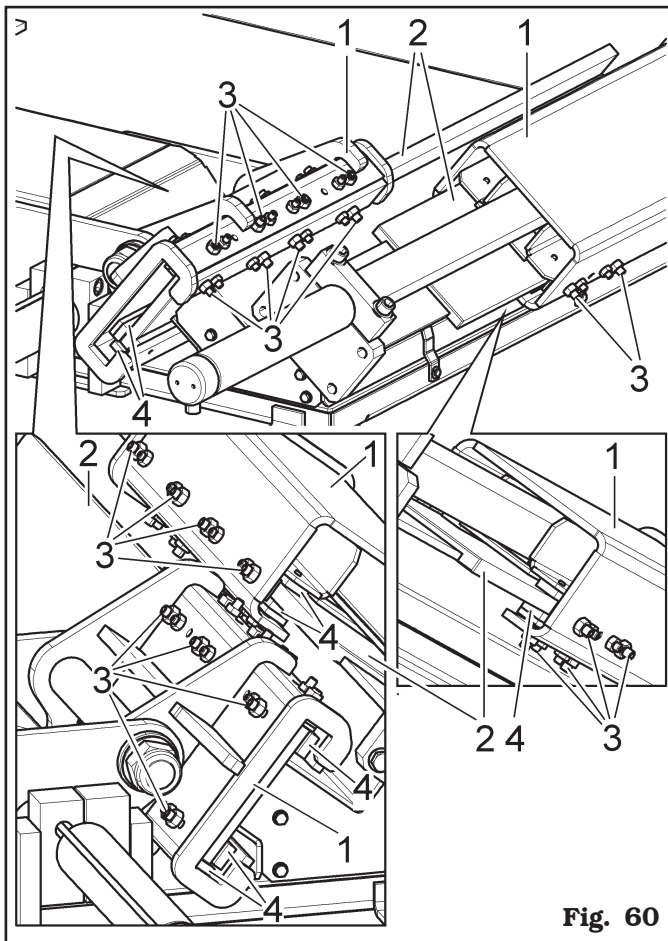


Fig. 60



ANY DAMAGE TO THE MACHINE DEVICES RESULTING FROM THE USE OF LUBRICANTS OTHER THAN THOSE RECOMMENDED IN THIS MANUAL WILL RELEASE THE MANUFACTURER FROM ANY LIABILITY!!



ANY EXTRAORDINARY MAINTENANCE OPERATION MUST ONLY BE CARRIED OUT BY PROFESSIONALLY QUALIFIED STAFF.








14.0 TROUBLESHOOTING TABLE

Possible troubles which might occur to the tyre-changer are listed below. The manufacturer disclaims all responsibility for damages to people, animals or objects due to improper operation by non-authorized personnel. In case of trouble, call Technical Service Department for instructions on how to service and/or adjust the machine in full safety to avoid any risk of damage to people, animals or objects.





In an emergency and before maintenance on tyre-changer, set the main switch to "0" and lock it in this position.



**CONTACT AUTHORIZED TECHNICAL SERVICE
do not try and service alone**

Problem	Possible cause	Remedy
Pump motor does not work but wheel holder mandrel motor works perfectly.	a) Hydraulic control unit damaged.	a) Call Technical Service Dept. 
When main switch is turned on, wheel holder mandrel does not turn whereas the pump motor works.	a) Gearbox change-over switch damaged.	a) Call Technical Service Dept. 
Power drop during wheel holder mandrel rotation.	a) Timing belt too loose.	a) Tension up the belt.
No pressure in the hydraulic system.	a) Pump damaged.	a) Replace pump. 
The mandrel opening pressure does not go down.	a) Pressure limiting valve jammed.	a) Download mandrel (remove wheel), completely undo adjusting handle. Perform many opening and closing cycles until jam release. 
The machine does not start.	a) No electricity supply. b) Overload cutouts not set. c) Transformer fuse blown.	a) Connect the electricity supply. b) Set the overload cutouts. c) Change the fuse.
Fluid leaks from union or pipeline.	a) Union not tightened correctly. b) Pipeline cracked.	a) Tighten the union. b) Call the after-sales service. 
A control device is remaining on.	a) The switch has broken. b) A solenoid valve has jammed.	a) Call the after-sales service. b) Call the after-sales service. 
The self-centring chuck cylinder is losing pressure.	a) The directional control valve is leaking. b) The gaskets are worn.	a) Call the after-sales service. b) Call the after-sales service. 
The motor stops during operation.	a) Overload cutout tripped.	Open the electrical panel and reset the overload cutout tripped.



Problem	Possible cause	Remedy
When a control device is operated the machine does not move at all.	<ul style="list-style-type: none"> a) Solenoid valve not receiving power. b) Solenoid valve jammed. c) Transformer fuse blown. d) Control unit not set correctly. 	<ul style="list-style-type: none"> a) Call the after-sales service. b) Call the after-sales service. c) Change the fuse. d) Call the after-sales service. 
No pressure in hydraulic circuit.	<ul style="list-style-type: none"> a) Power unit motor turning in wrong direction. b) Power unit pump has failed. c) No oil in power unit tank. 	<ul style="list-style-type: none"> a) Restore correct rotation direction by changing socket connection. b) Call the after-sales service. c) Fill power unit tank with oil 
Machine operates in jerks.	<ul style="list-style-type: none"> a) Not enough fluid in power unit tank. b) Control unit switch has failed. 	<ul style="list-style-type: none"> a) Top up with oil. b) Call the after-sales service. 
The mandrel doesn't rotate. (Only for G9256D.15, G9256TD.15, G9256.11SL (VARGNAV43AD), G9256.15SL (inverter version) (VARGNAV43AD), G10360D.15 and G10360TD.15)	<ul style="list-style-type: none"> a) The first current threshold has been exceeded. b) The second current threshold has been exceeded. c) Lack of supply. d) Insufficient net voltage. e) Net voltage too high. f) Sudden and short drop of net voltage. g) The second temperature threshold has been exceeded. 	<ul style="list-style-type: none"> a) Wait for the automatic reset lifting the pedal. b) Disconnect the machine from the net for 30 seconds at least, then reconnect. If the problem persists, check the harness. c) Connect the supply. d) Shorten the length of possible extension cable to the machine or raise the leads section (disconnect and reconnect). e) Disconnect the machine from the net for 30 seconds at least, then reconnect. f) Disconnect the machine from the net for 30 seconds at least, then reconnect. g) The machine does not start until the temperature does not lower under the safety limit.
The mandrel does not reach the maximum speed. (Only for G9256D.15, G9256TD.15, G9256.11SL (VARGNAV43AD), G9256.15SL (inverter version) (VARGNAV43AD), G10360D.15 and G10360TD.15)	<ul style="list-style-type: none"> a) The first temperature threshold has been exceeded. b) Raised mechanical resistance. 	<ul style="list-style-type: none"> a) Let the motor body cool. b) Make the mandrel rotate loadless for some minutes. If it does not accelerate, call the after-sales service. 



15.0 TECHNICAL DATA

15.1 G9256.11SL technical data

Mandrel motor:	power 1,3-1,85 kW three-phase power supply 400V (50 Hz)
Mandrel rotation maximum speed:	4-8 rpm
Wheel maximum diameter:	2360 mm / 93"
Wheel maximum width:	1100 mm / 43"
Wheel maximum weight:	2000 Kg
Self-centring chuck locking:	11" - 56" (with extensions)
Minimum locking hole:	90 mm
Power unit motor:	power 1,85-2,5 kW three-phase power supply 400V (50 Hz)
Operating pressure:	160 bar
Weight:	1050 Kg
Noise level:	< 80 dB (A)

15.2 G9256.11ST technical data

Mandrel motor:	power 1,3-1,85 kW three-phase power supply 400V (50 Hz)
Mandrel rotation maximum speed:	4-8 rpm
Wheel maximum diameter:	2360 mm / 93"
Wheel maximum width:	1100 mm / 43"
Wheel maximum weight:	2000 Kg
Self-centring chuck locking:	11" - 56" (with extensions)
Minimum locking hole:	90 mm
Power unit motor:	power 1,85-2,5 kW three-phase power supply 400V (50 Hz)
Operating pressure:	160 bar
Weight:	1000 Kg
Noise level:	< 80 dB (A)

15.3 Technical data G9256.15 - G9256T.15

Mandrel motor:	power 1,3-1,85 kW three-phase power supply 400V (50 Hz)
Mandrel rotation maximum speed:	4-8 rpm
Wheel maximum diameter:	2360 mm / 93"
Wheel maximum width:	1500 mm / 59"
Wheel maximum weight:	2300 Kg
Self-centring chuck locking:	11" - 56" (with extensions)
Minimum locking hole:	90 mm
Power unit motor:	power 1,85-2,5 kW three-phase power supply 400V (50 Hz)
Operating pressure:	160 bar
Weight:	1150 Kg
Noise level:	< 80 dB (A)

15.4 G9256A.15 technical data

Mandrel motor:	power 1,3-1,85 kW three-phase power supply 400V (50 Hz)
Mandrel rotation maximum speed:	4-8 rpm
Wheel maximum diameter:	2360 mm / 93"
Wheel maximum width:	1500 mm / 59"
Wheel maximum weight:	2300 Kg
Self-centring chuck locking:	11" - 56" (with extensions)
Minimum locking hole:	90 mm
Power unit motor:	power 1,85-2,5 kW three-phase power supply 400V (50 Hz)
Operating pressure:	160 bar
Weight:	1150 Kg
Noise level:	< 80 dB (A)

15.5 Technical data G9256D.15 - G9256TD.15

Mandrel motor:	power 2,2 kW three-phase power supply 400V (50 Hz)
Mandrel rotation maximum speed:	1 - 6 - 12 rpm
Wheel maximum diameter:	2360 mm / 93"
Wheel maximum width:	1500 mm / 59"

Wheel maximum weight:	2300 Kg
Self-centring chuck locking:	11"- 56" (with extensions)
Minimum locking hole:	90 mm
Power unit motor:	power 1,85-2,5 kW three-phase power supply 400V (50 Hz)
Operating pressure:	160 bar
Weight:	1150 Kg
Noise level:	< 80 dB (A)

15.6 G9256.15SL technical data

Mandrel motor:	power 1,3-1,85 kW three-phase power supply 400V (50 Hz)
Mandrel rotation maximum speed:	4-8 rpm
Mandrel rotation maximum speed (inverter version):	1 - 6 - 12 rpm
Maximum wheel diameter:	2360 mm / 93"
Wheel maximum width:	1500 mm / 59"
Wheel maximum weight:	2300 Kg
Self-centring chuck locking:	11"- 56" (with extensions)
Minimum locking hole:	90 mm
Power unit motor:	power 1,85-2,5 kW three-phase power supply 400V (50 Hz)
Operating pressure:	160 bar
Weight:	1120 Kg
Noise level:	< 80 dB (A)

15.7 Technical data G10360.15 - G10360T.15

Mandrel motor:	power 1,5-2,2 kW three-phase power supply 400V (50 Hz)
Mandrel rotation maximum speed:	4-8 rpm
Maximum wheel diameter:	2700 mm / 106"
Wheel maximum width:	1500 mm / 59"
Wheel maximum weight:	2600 Kg
Self-centring chuck locking:	11"- 60" (with extensions)
Minimum locking hole:	90 mm
Power unit motor:	power 1,85-2,5 kW three-phase power supply 400V (50 Hz)
Operating pressure:	180 bar
Weight:	1400 Kg
Noise level:	< 80 dB (A)

15.8 G10360A.15 technical data

Mandrel motor:	power 1,5-2,2 kW three-phase power supply 400V (50 Hz)
Mandrel rotation maximum speed:	4-8 rpm
Maximum wheel diameter:	2700 mm / 106"
Wheel maximum width:	1500 mm / 59"
Wheel maximum weight:	2600 Kg
Self-centring chuck locking:	11"- 60" (with extensions)
Minimum locking hole:	90 mm
Power unit motor:	power 1,85-2,5 kW three-phase power supply 400V (50 Hz)
Operating pressure:	180 bar
Weight:	1450 Kg
Noise level:	< 80 dB (A)

15.9 Technical data G10360D.15 - G10360TD.15

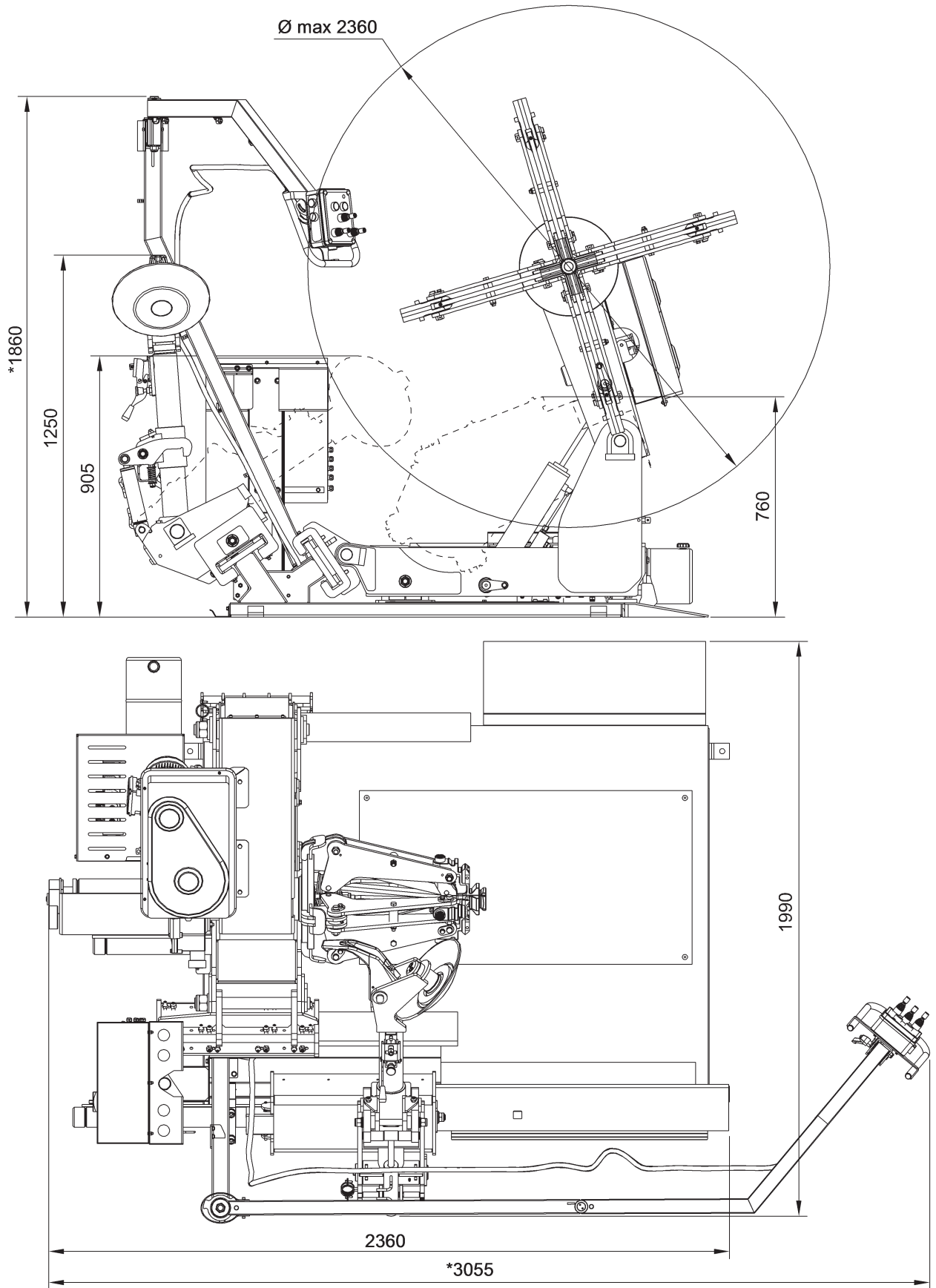
Mandrel motor:	power 2,2 kW three-phase power supply 400V (50 Hz)
Mandrel rotation maximum speed:	1 - 6 - 12 rpm
Maximum wheel diameter:	2700 mm / 106"
Wheel maximum width:	1500 mm / 59"
Wheel maximum weight:	2600 Kg
Self-centring chuck locking:	11"- 60" (with extensions)
Minimum locking hole:	90 mm
Power unit motor:	power 1,85-2,5 kW three-phase power supply 400V (50 Hz)
Operating pressure:	180 bar
Weight:	1400 Kg
Noise level:	< 80 dB (A)



15.10 Dimensions

G9256.11SL

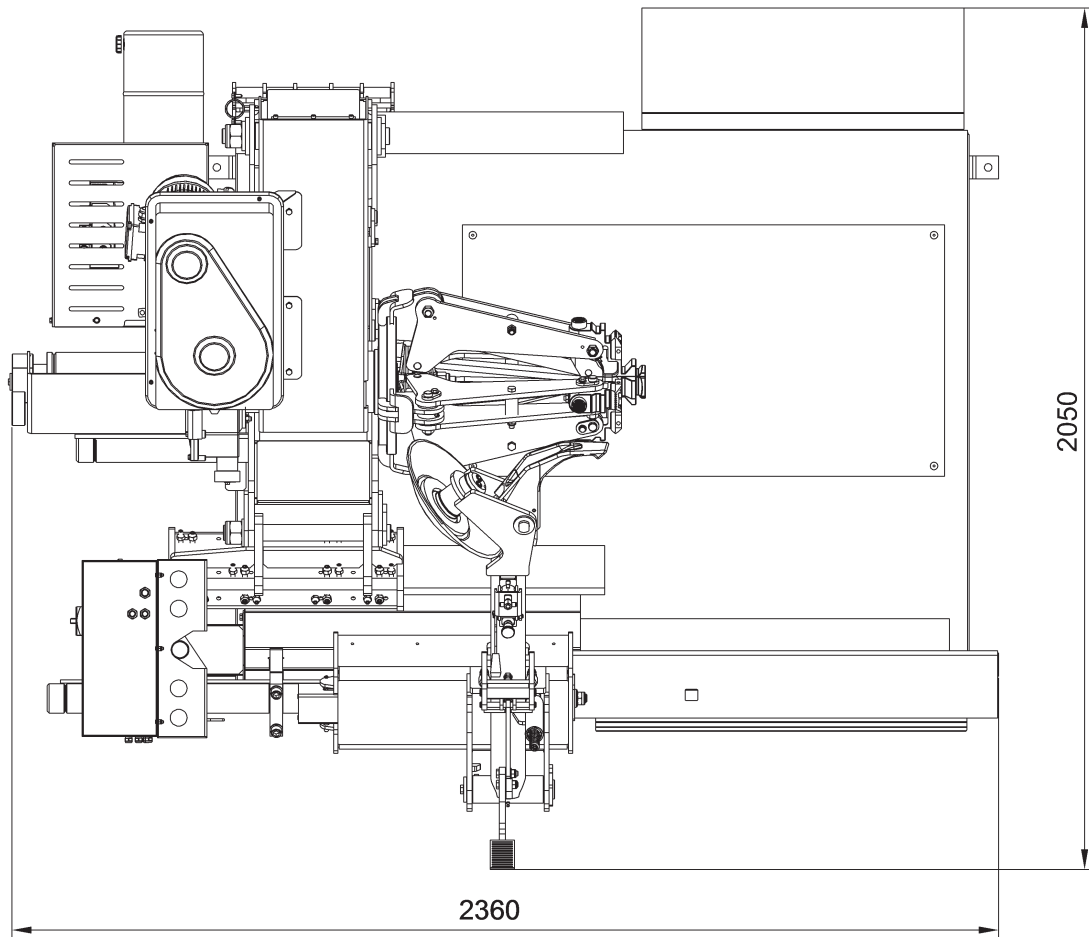
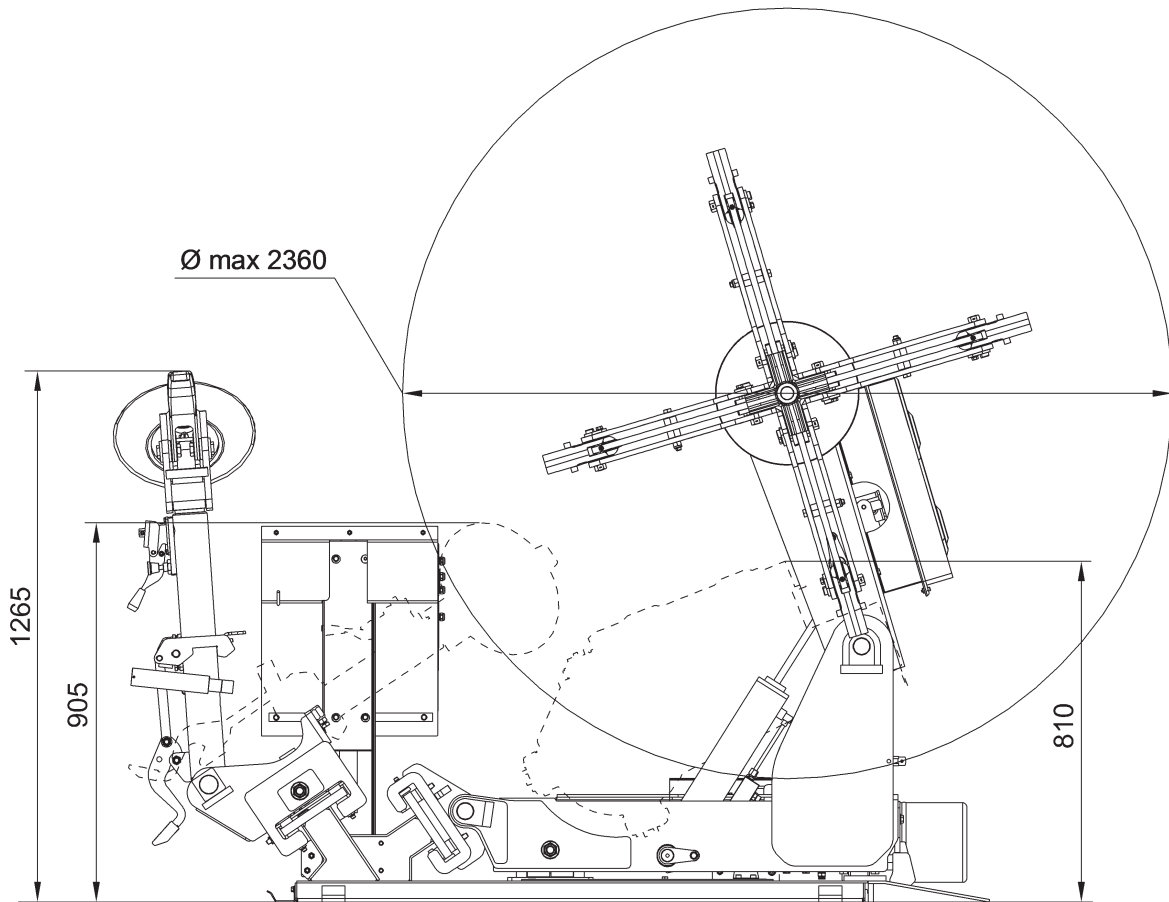
Fig. 61



* Valid only for the versions with aerial control version (VARGNAV43ASL) and inverter version (VARGNAV43AD)

G9256.11ST

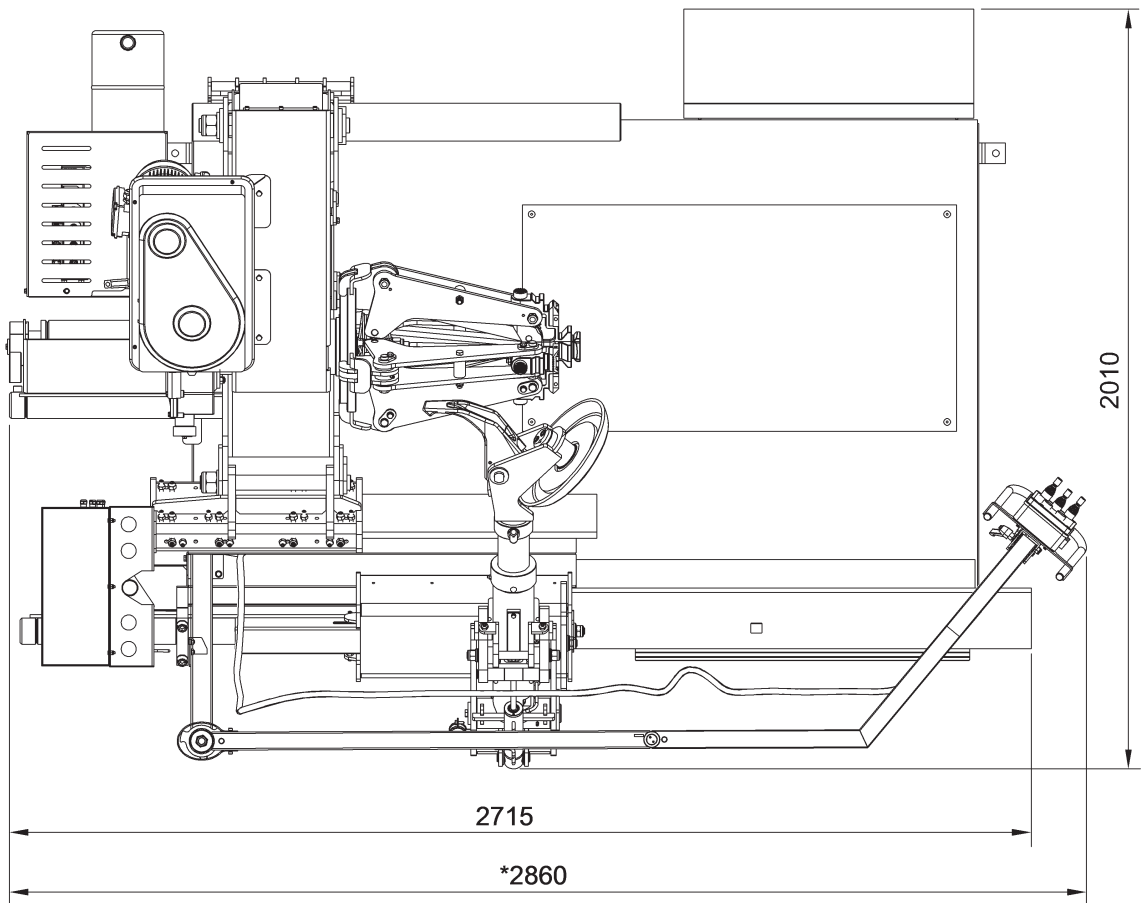
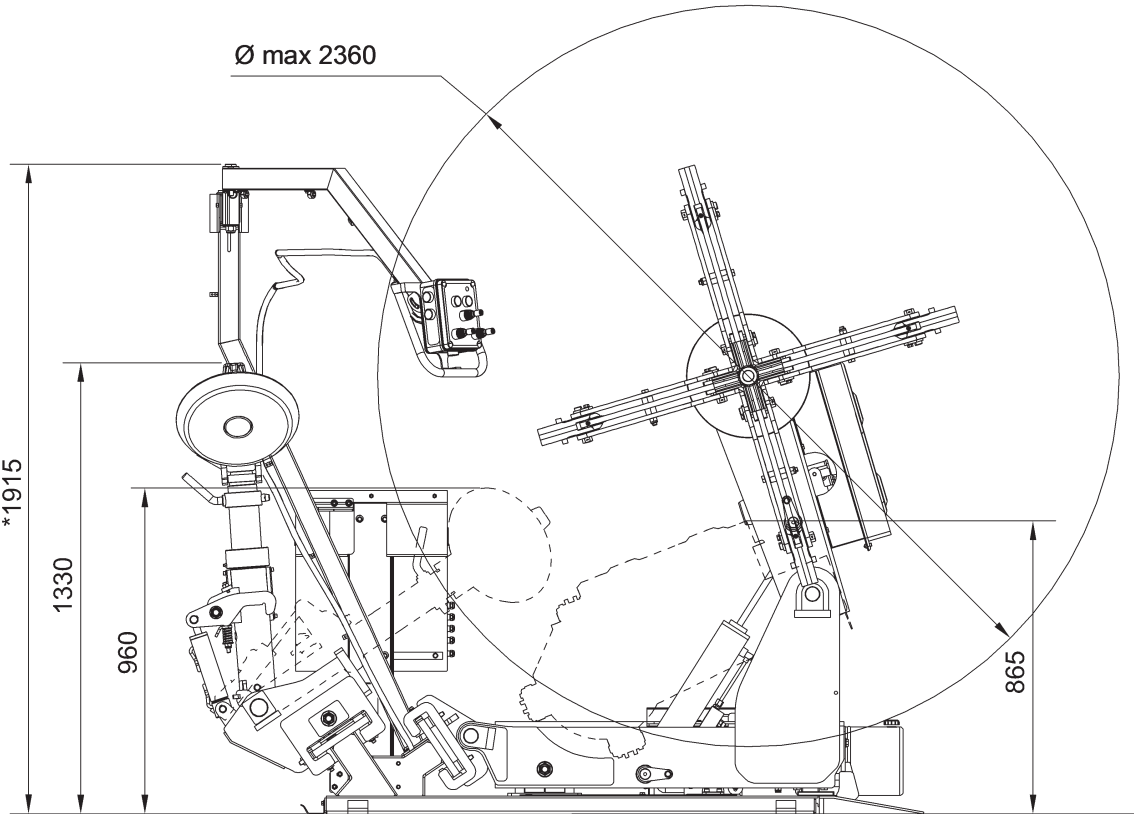
Fig. 62





G9256.15 - G9256T.15 - G9256D.15 - G9256TD.15

Fig. 63

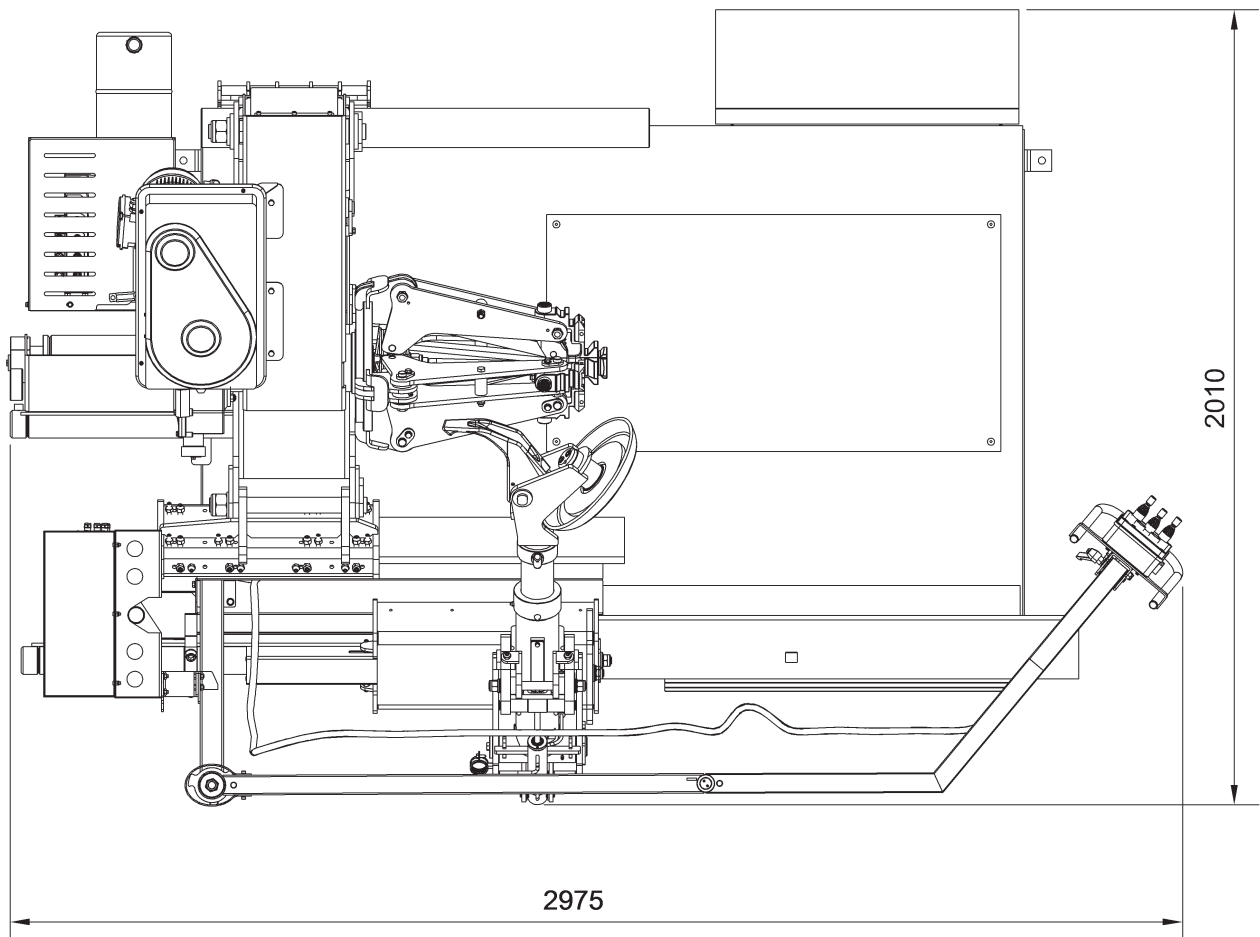
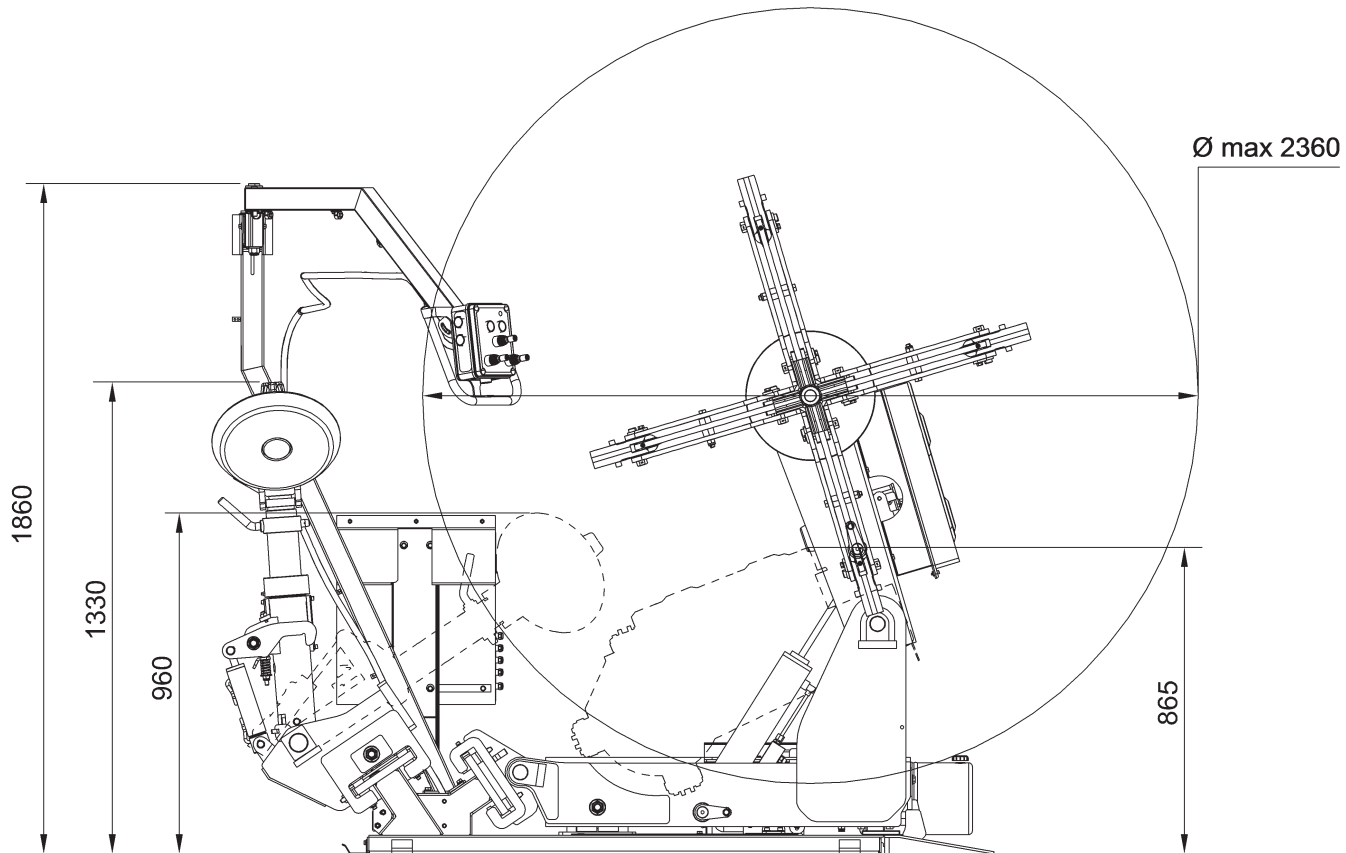


* Valid only for version with aerial control with inverter (G9256.15 - G9256T.15 (VARGNAV43A))



G9256A.15

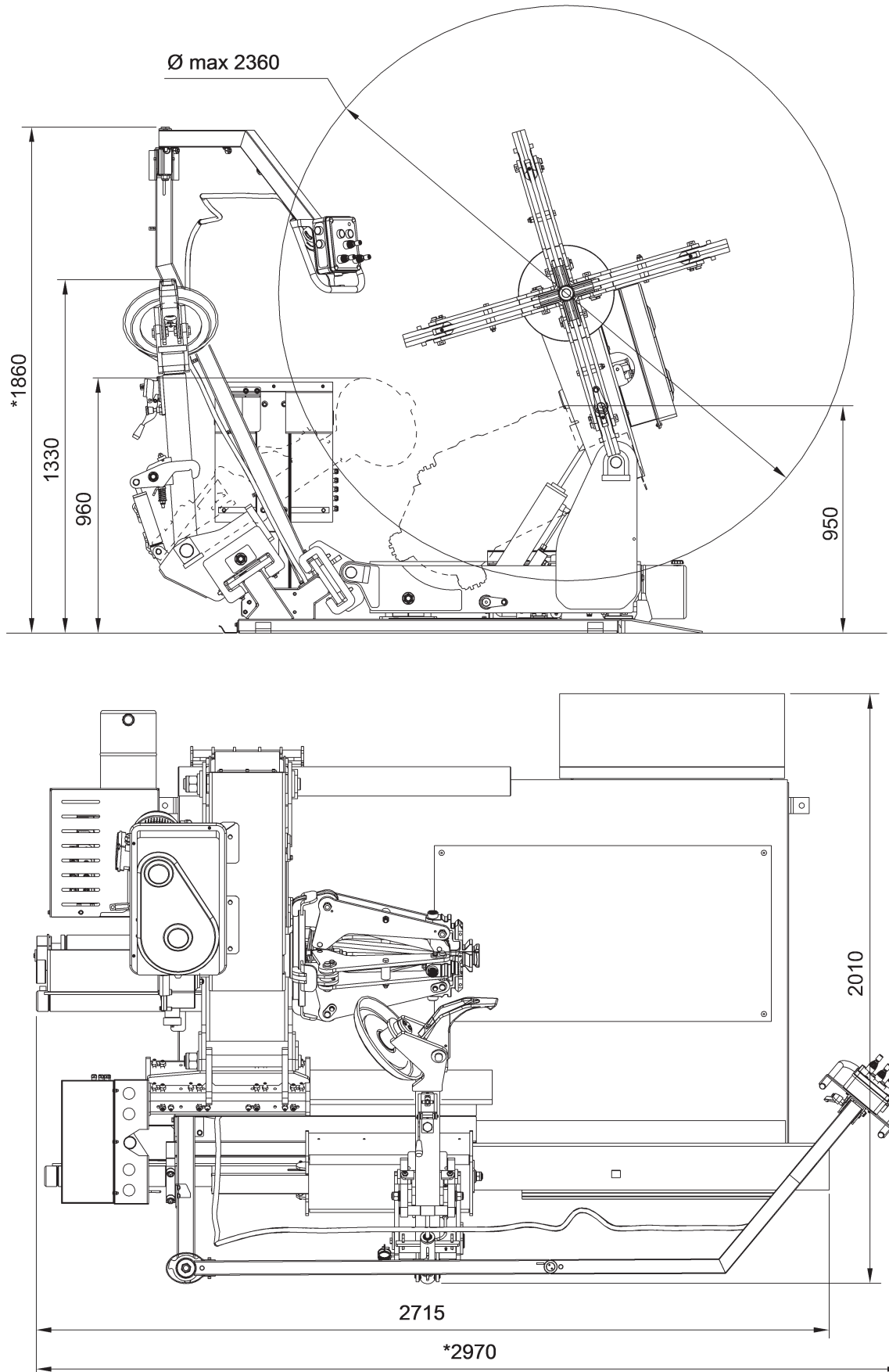
Fig. 64





G9256.15SL

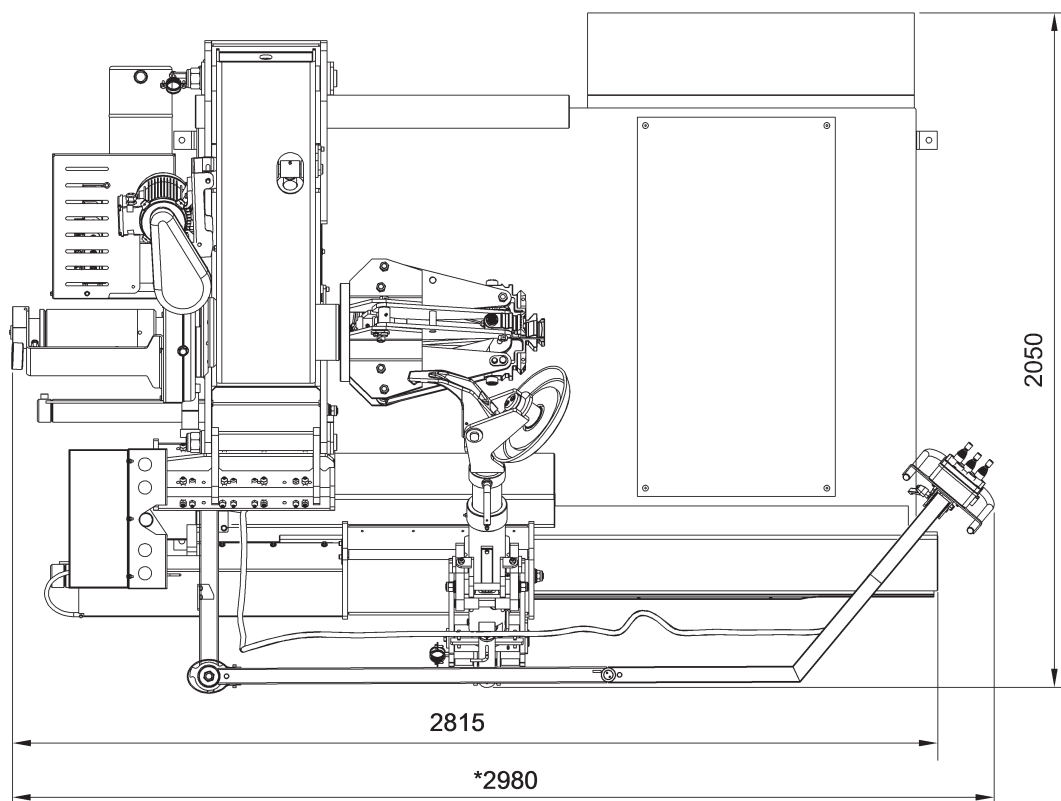
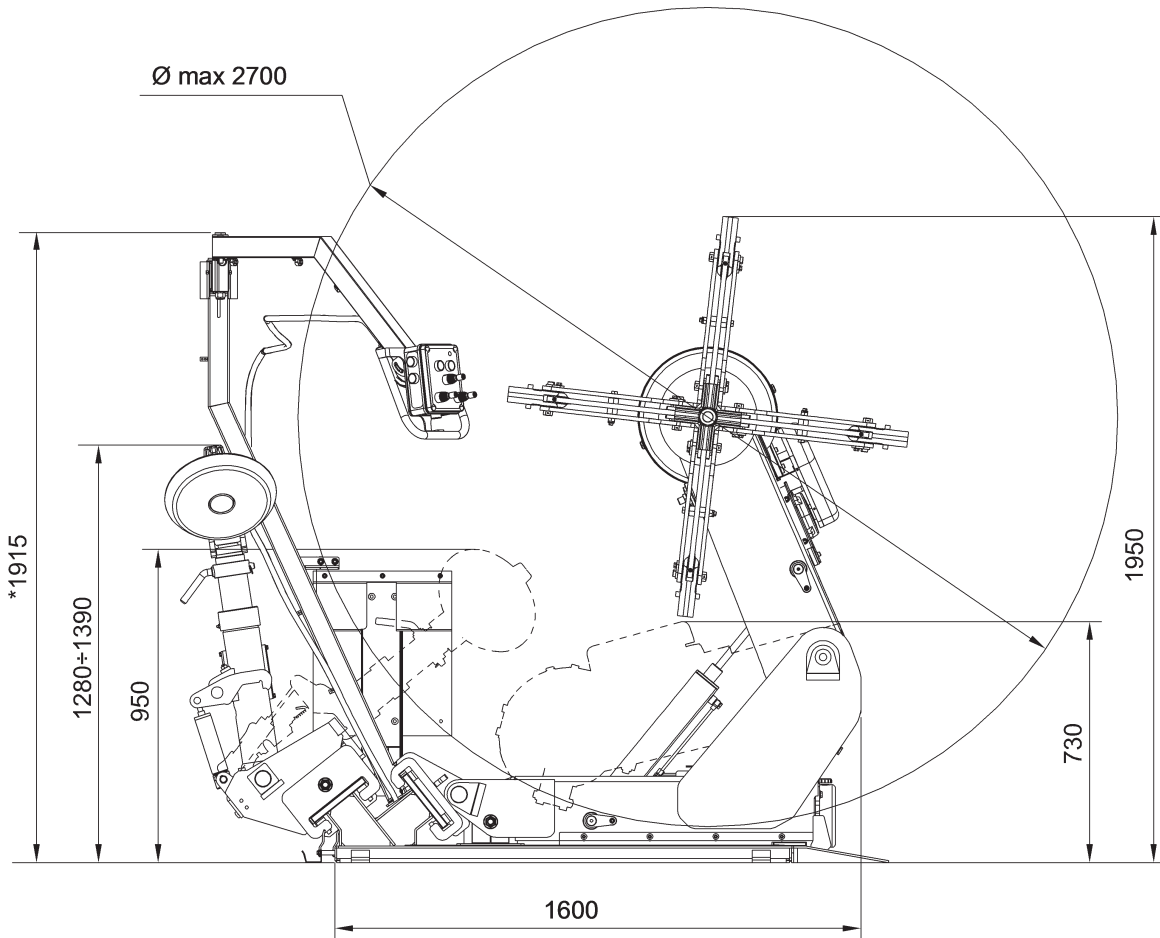
Fig. 65



* Valid only for the versions with aerial control version (VARGNAV43ASL) and inverter version (VARGNAV43AD)

G10360.15 - G10360T.15 - G10360D.15 - G10360TD.15

Fig. 66

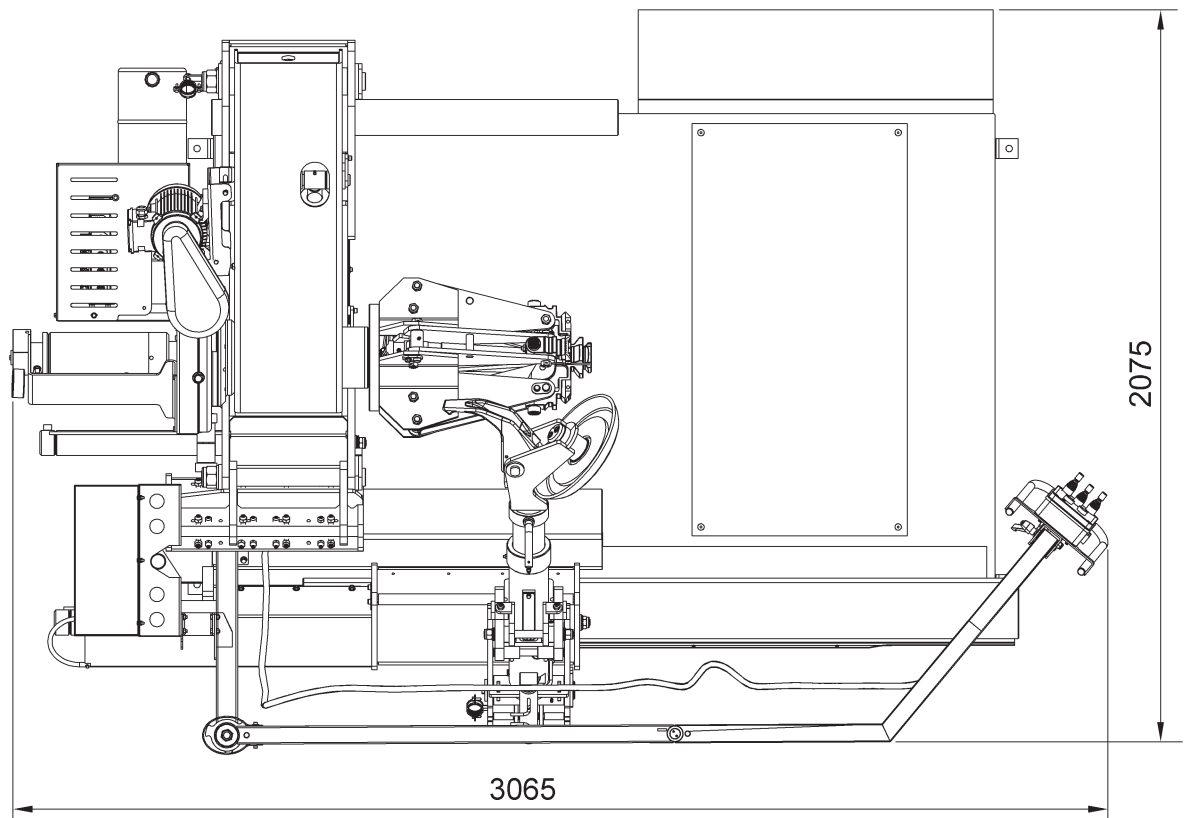
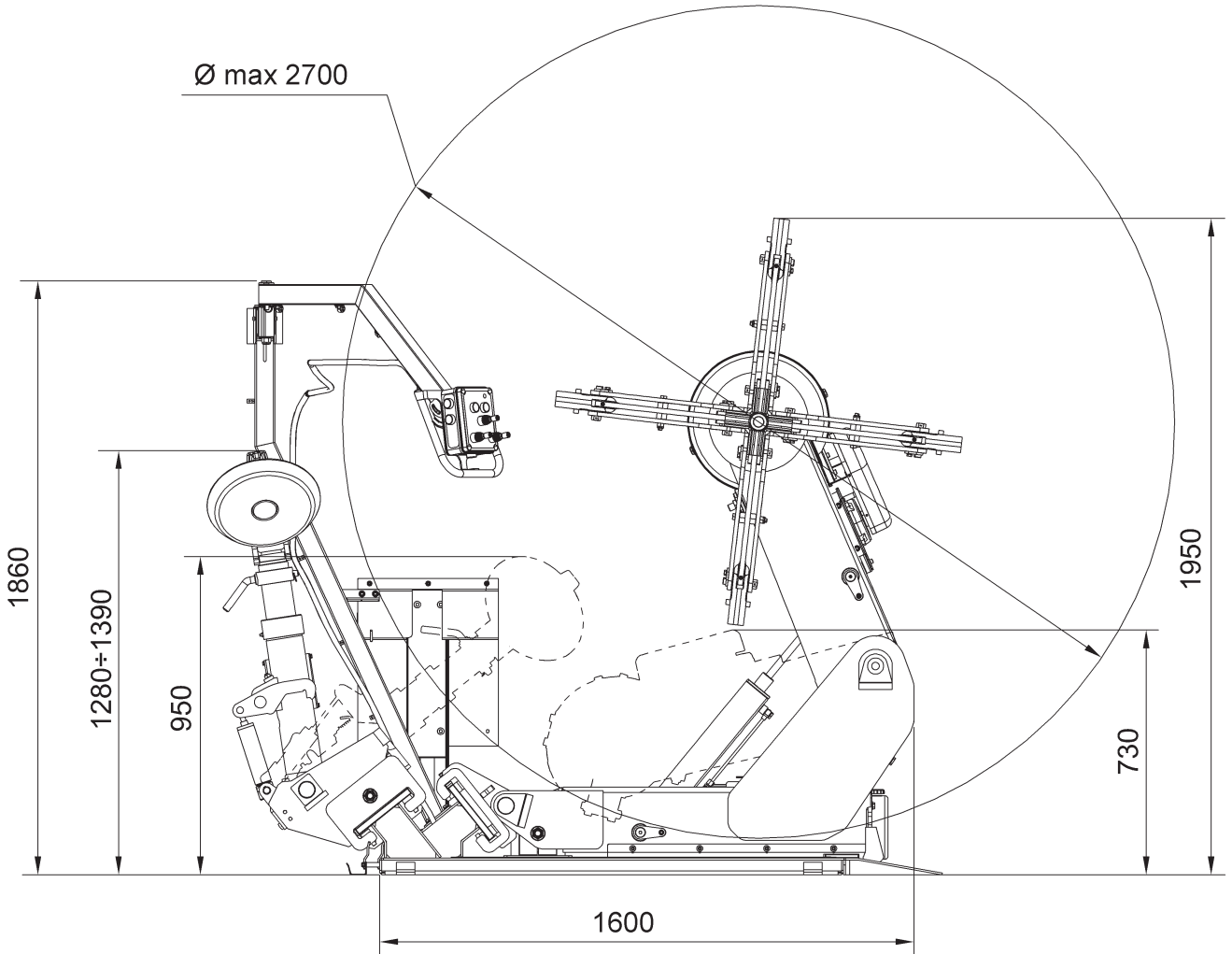


* Valid only for version with aerial control with inverter (G10360.15 - G10360T.15(VARGNAV63A)
 G10360.15 - G10360T.15 (G10360D.15))



G10360A.15

Fig. 67





16.0 STORING

If storing for long periods (6 months or longer) disconnect the main power supply and take measures to protect the machine from dust build-up. Lubricate parts that could be damaged from drying out. When putting the machine back into operation replace the rubber pads and the mounting tool. Moreover, carry out a verification of machine perfect functioning.

17.0 SCRAPPING

When the decision is taken not to make further use of the machine, it is advisable to make it inoperative by removing the connection pressure hoses. The machine is to be considered as special waste and should be dismantled into homogeneous parts. Dispose of it in accordance with current legislation.

Instructions for the correct management of waste from electric and electronic equipment (WEEE) according to the Italian legislative decree 49/14 and subsequent amendments.

In order to inform the users on the correct way to dispose the product (as required by the article 26, paragraph 1 of the Italian legislative decree 49/14 and subsequent amendments), we communicate what follows: the meaning of the crossed dustbin symbol reported on the equipment indicates that the product must not be thrown among the undifferentiated rubbish (that is to say together with the "mixed urban waste"), but it has to be managed separately, to let the WEEE go through special operations for their reuse or treatment, in order to remove and dispose safely the waste that could be dangerous for the environment and to extract and recycle the raw materials to be reused.

18.0 REGISTRATION PLATE DATA

		Ravaglioli s.p.a. 40037 - PONTECCHIO MARCONI/ITALIA TEL. 051-6781511 - TELEX 510697 RAV I P.O.B. 1690 - 40100 BOLOGNA/ITALIA FAX + 39 (051) 846349	
MODEL			
SERIAL N°	YEAR		

The validity of the Conformity Declaration enclosed to this manual is also extended to products and/or devices the machine model object of the Conformity Declaration can be equipped with.

Said plate must always be kept clean from grease residues or filth generally.



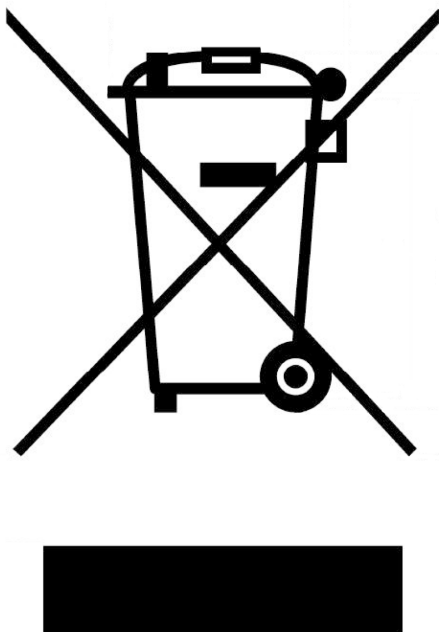
ATTENTION: TAMPERING WITH, CARVING, CHANGING ANYHOW OR EVEN REMOVING MACHINE IDENTIFICATION PLATE IS ABSOLUTELY FORBIDDEN; DO NOT COVER IT WITH TEMPORARY PANELS, ETC., SINCE IT MUST ALWAYS BE VISIBLE.

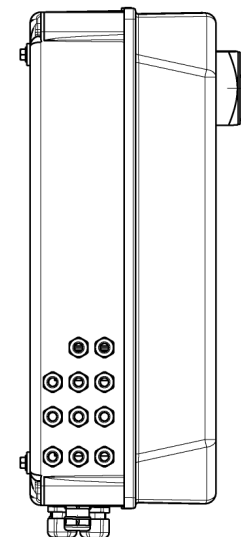
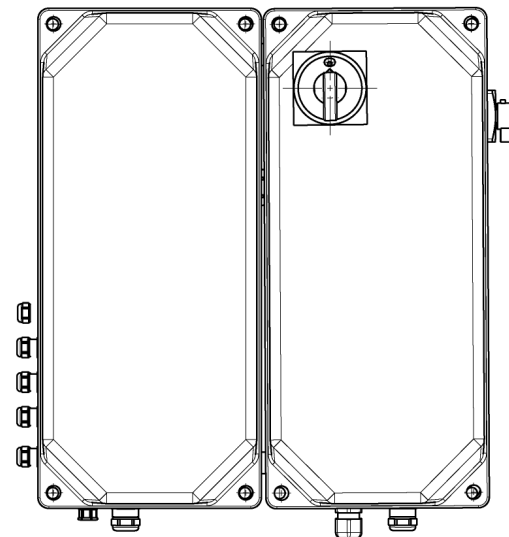
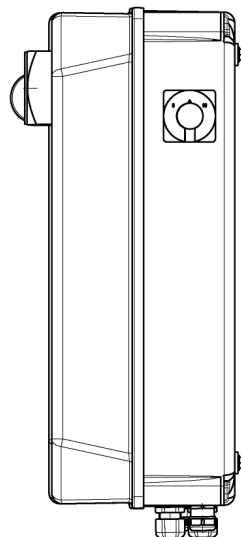
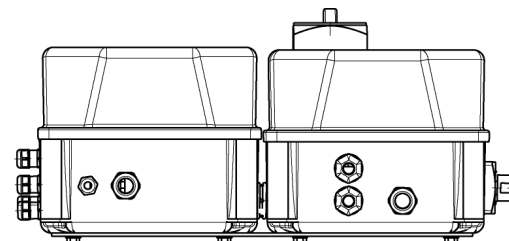
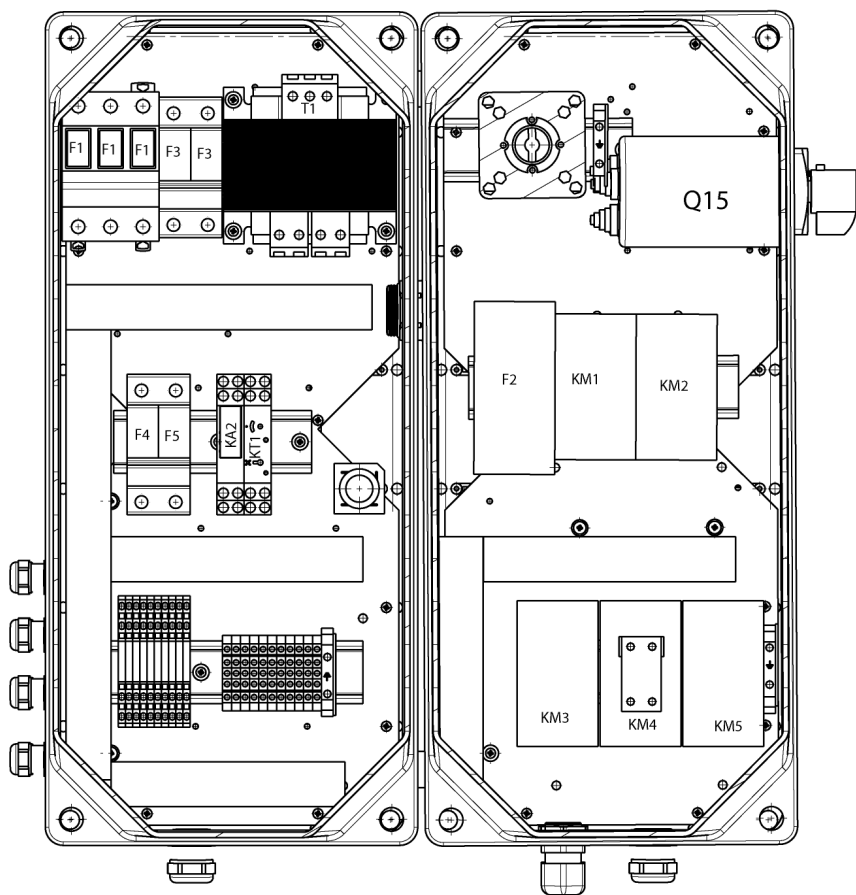
WARNING: Should the plate be accidentally damaged (removed from the machine, damaged or even partially illegible) inform immediately the manufacturer.

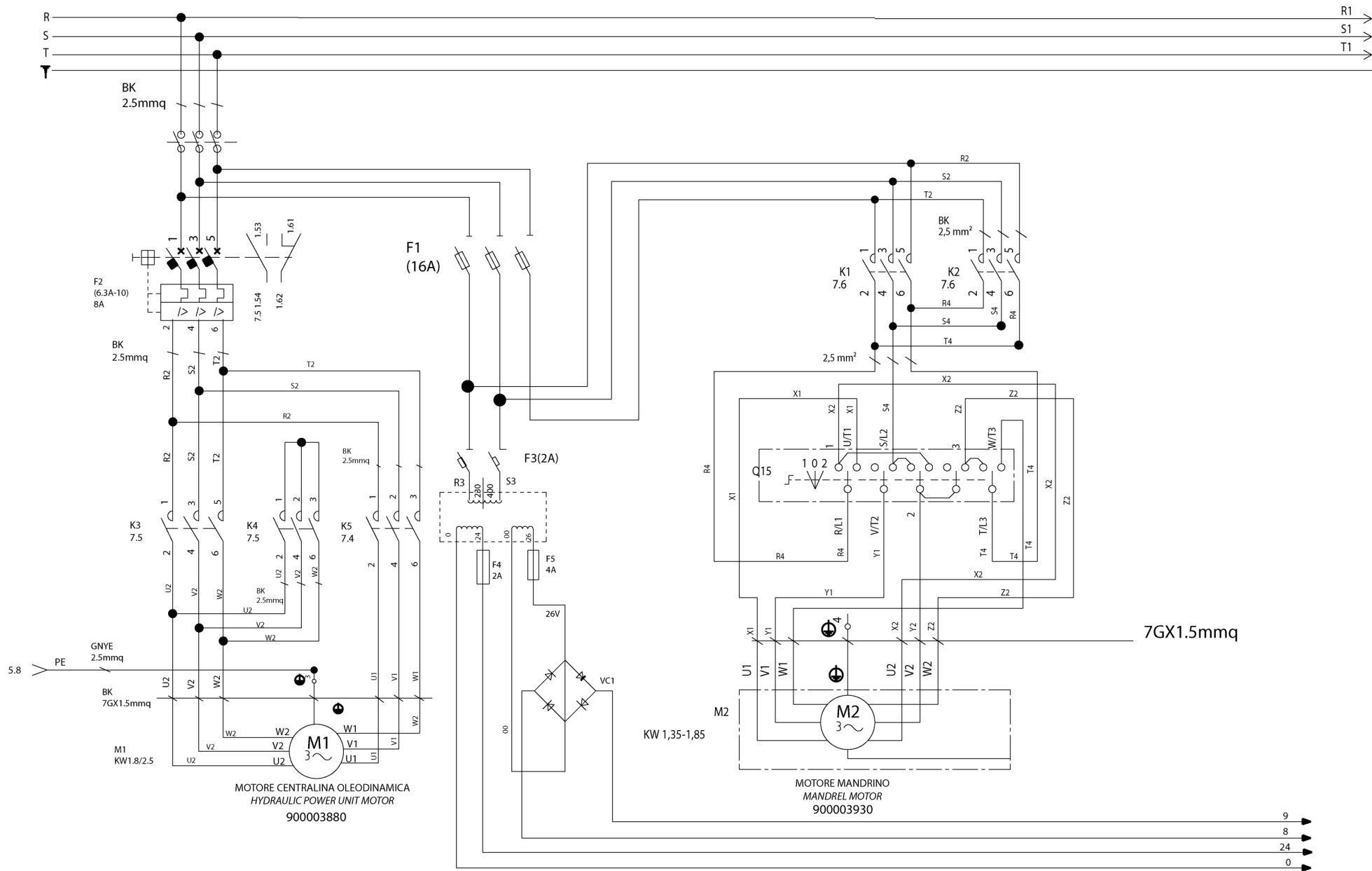
19.0 FUNCTIONAL DIAGRAMS

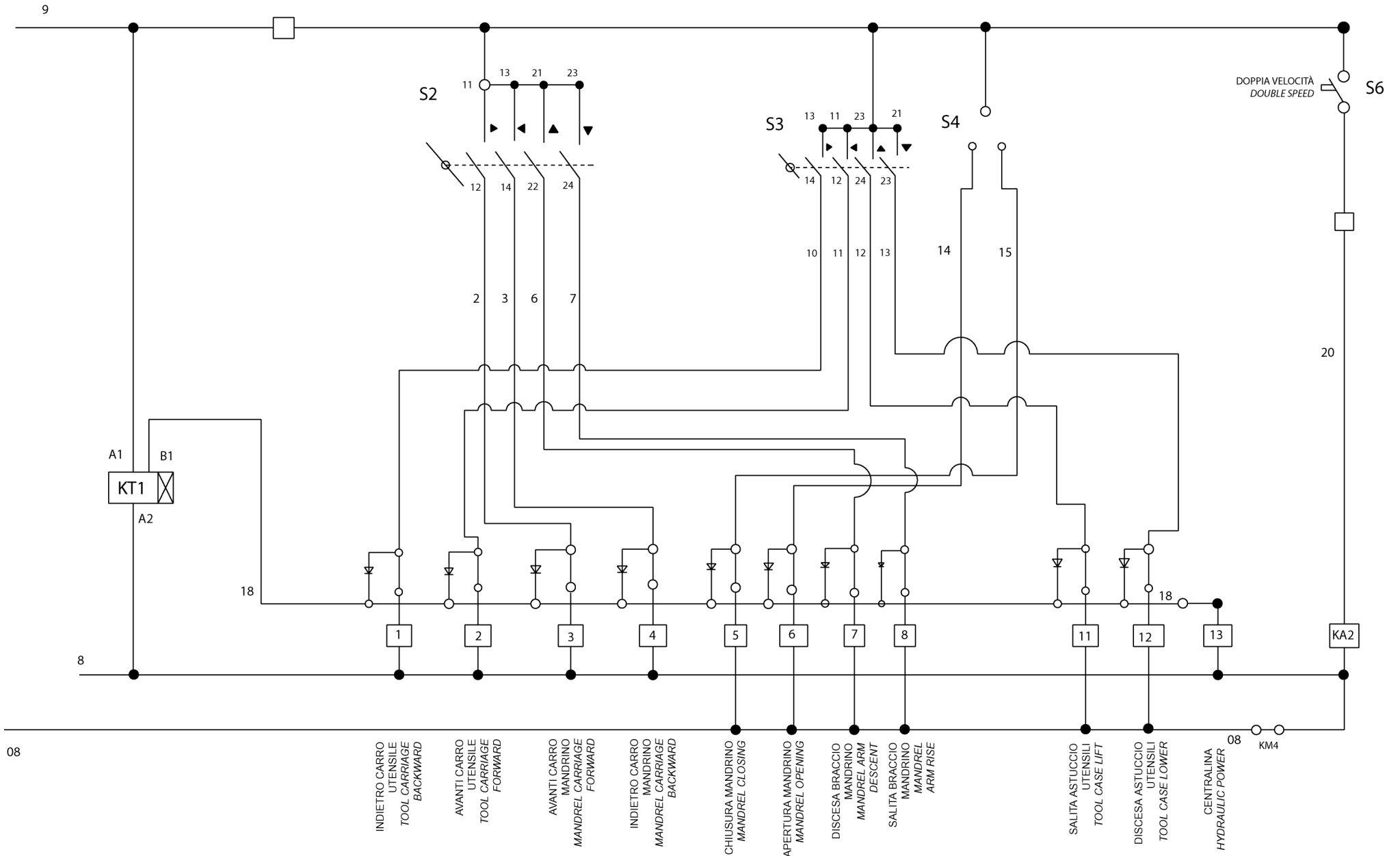
Here follows a list of the machine functional diagrams.

Fig. 68

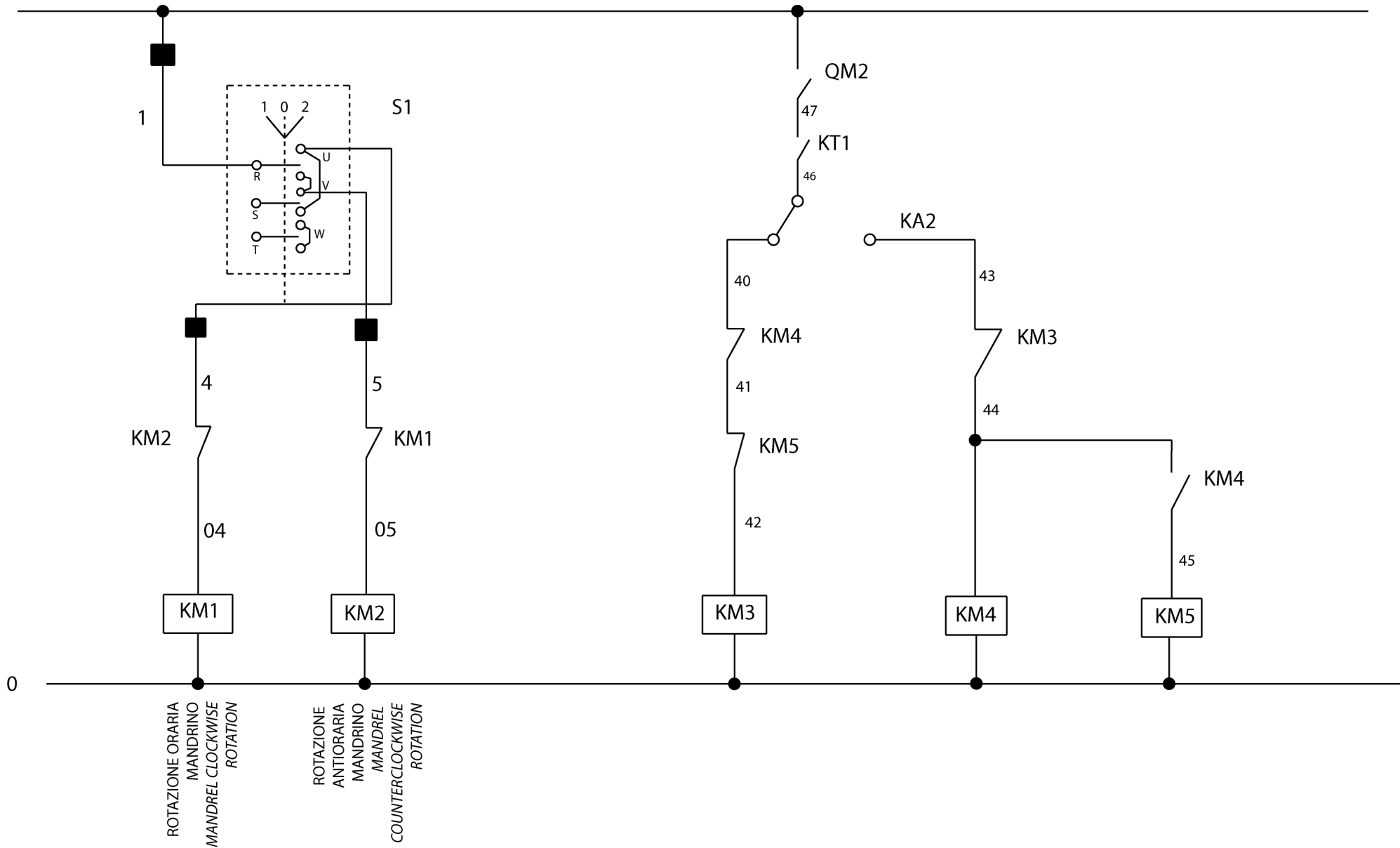








08



**LISTA DEI COMPONENTI - LIST OF COMPONENTS - TEILELISTE
LISTE DES PIÈCES DÉTACHÉES - LISTA DE PIEZAS**

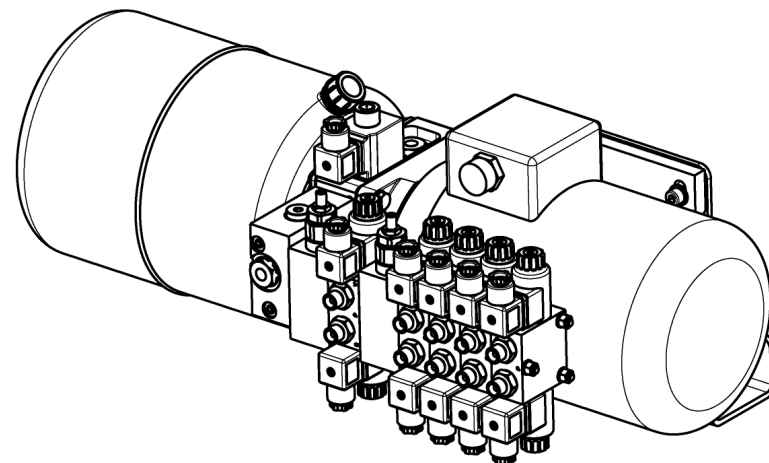
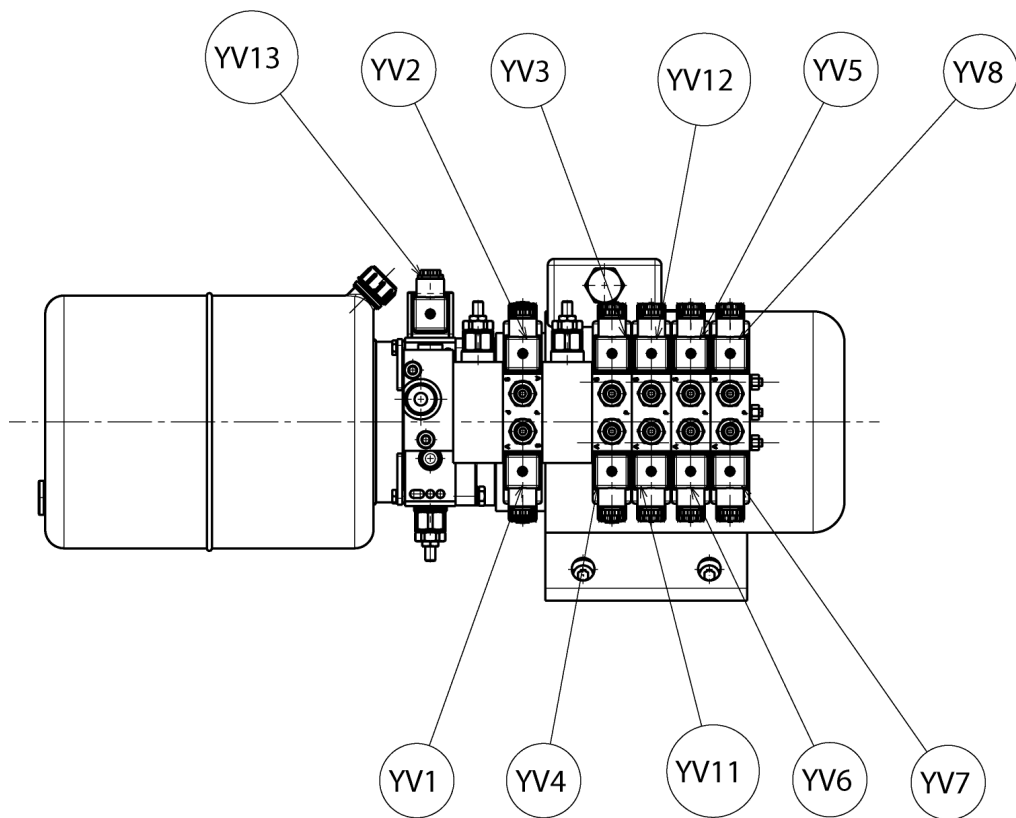
Tavola N°A - Rev. 2

752205800

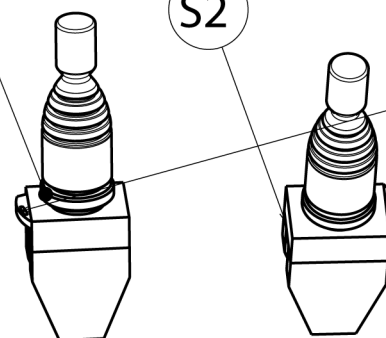
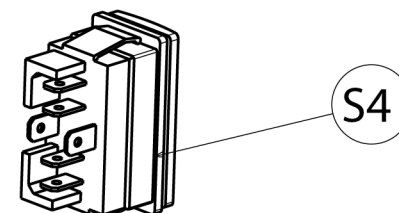
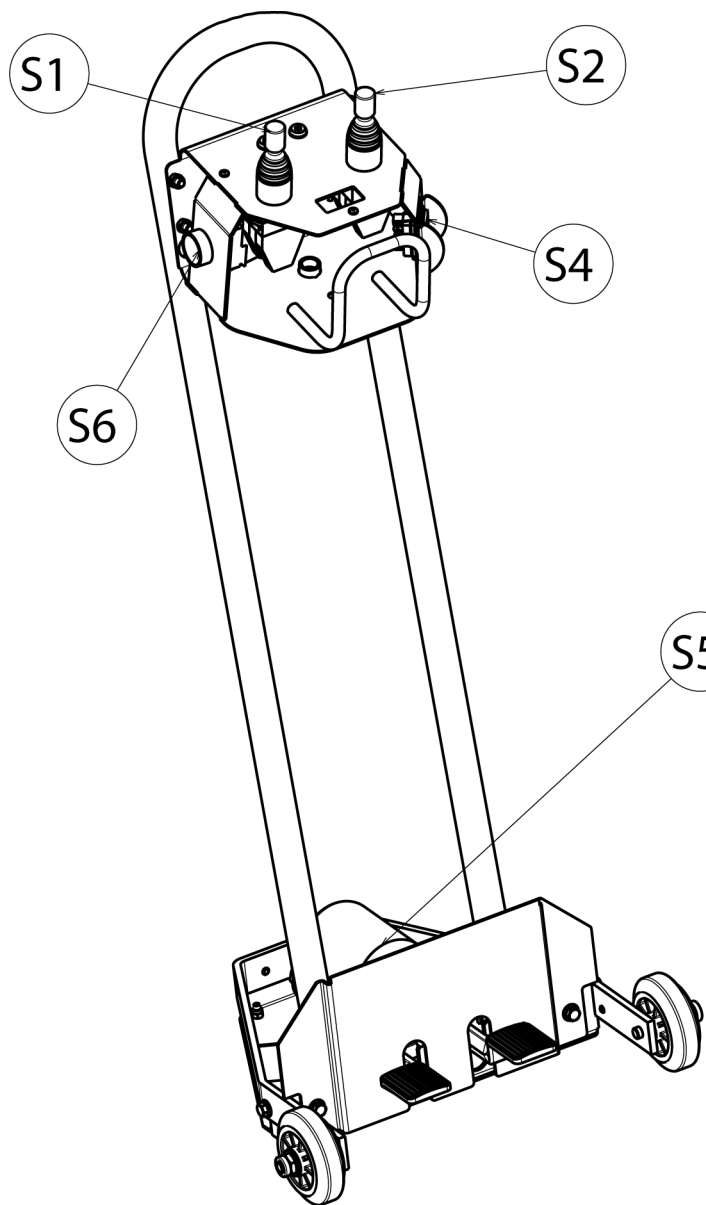
SCHEMA ELETTRICO (G9256.11SL - G9256.15SL) 4/9
ELECTRICAL SCHEME (G9256.11SL - G9256.15SL) 4/9
SCHALTPLAN (G9256.11SL - G9256.15SL) 4/9
SCHEMA ELECTRIQUE (G9256.11SL - G9256.15SL) 4/9
ESQUEMA ELECTRICO (G9256.11SL - G9256.15SL) 4/9

Pag. 57 di 168

G9256.11SL - G9256.11ST - G9256.15 - G9256T.15
G9256A.15 - G9256D.15 - G9256TD.15 - G9256.15SL
G10360.15 - G10360T.15 - G10360A.15
G10360D.15 - G10360TD.15



 RAVAGLIOLI S.p.A.	LISTA DEI COMPONENTI - LIST OF COMPONENTS - TEILELISTE LISTE DES PIÈCES DÉTACHÉES - LISTA DE PIEZAS		SCHEMA ELETTRICO (G9256.11SL - G9256.15SL) 5/9 ELECTRICAL SCHEME (G9256.11SL - G9256.15SL) 5/9 SCHALTPLAN (G9256.11SL - G9256.15SL) 5/9 SCHEMA ELECTRIQUE (G9256.11SL - G9256.15SL) 5/9 ESQUEMA ELECTRICO (G9256.11SL - G9256.15SL) 5/9	Pag. 58 di 168 <small>G9256.11SL - G9256.11ST - G9256.15 - G9256T.15 G9256A.15 - G9256D.15 - G9256TD.15 - G9256.15SL G10360.15 - G10360T.15 - G10360A.15 G10360D.15 - G10360TD.15</small>
	Tavola N°A - Rev. 2	752205800		



MOLLA PER LIBERARE I
CONTATTI VERSO IL LATO
OPPOSTO
SPRING FOR CONTACTS RELEASE
TOWARDS OPPOSITE SIDES

RIFERIMENTO	DESCRIZIONE	DATI TECNICI	CODICE	QUANTITA	RIFERIMENTO DOCUMENTO
	SEZIONATORE 16A 3 POLI	ART.SE163003B 16A 3P BL/POR	518223	1	
	MANOPOLA GIALLO/ROSSA GIOVENZ	a.012/0001-1 LUCCHETTO	518226	1	
KT1	TIMER RIT.DISECCIT.	TIMER RIT.DISECCIT. 12 240 AC DC	521104	1	
Q15	COMMUTATORE 20A	20A C0013.09.11	518189	1	
F1	PORTAFUSIBILE	3 POLI SEZIONABILE 10,3x38 32A 690V	515035	1	
	FUSIBILE	10,3x38 16A 500V aM RITARDATO	507045	3	
F2	INTERRUTT.6-10A SLVAMOTORE	4-6.3A ART.GV2 ME14SCHNEIDER	518277	1	
				1	
F3-F4-F5	PORTAFUSIBILE	2 POLI SEZIONABILE 10,3x38 32A 690V	515027	2	
	FUSIBILE	10,3X38 2A 500V RAPIDO	507019	3	
	FUSIBILE	10.3X38 4A 500V	507097	1	
K1M-K2M-K3M-K4M-K5M	CONTATTORE TRIPOLARE	9A AC3 400V 4,2KW 1NC 24Vac 50/60Hz	522137	5	
	CONTATTI AUSILIARI BFX 10 11 1N0 1NC		522147	1	
	MORSETTO 2.5mmq C/DIODO 1N4007		510218	10	
	MORSETTO A MOLLA 2 PIAN.1.5mmq		510217	11	
	MORSETTO G/V 4mmq ART.TEO.4 CABUR T0430 +PIASTR.TERM.TEO.4		510150 + 510209	3	
VC1	PONTE RADDRIZZATORE VC1	-	B1296200	1	
	CONDENSATORE C1-C2		B1296300	1	
	INS.CAVO ALIMENTAZIONE QUADRO			1	
	INS.CAVO MOTORE MANDRINO			1	
	INS.CAVO MOTORE CENTRALINA	-		1	
	INS.CAVO MANIPOLATORE			1	
	INS.CAVO ELETTROVALV.Q1-Q2- Q3-Q4-Q5-Q6-Q7-Q8-Q11-Q12-Q13			1+1+1+1+1+1+ 1+1+1+1+1	
KA2 + ZOCOLO	RELE'A 2 CONTATTI + ZOCOLO A 2 CONTATTI	8A 24VAC	557017 + 557018	1 + 1	
S1/S2	MANIPOLATORE	4 POS.+CENTR.TEMPORANEE Ø22	517157AS	2	5.7
S4	PULSANTE BASCULANTE	-	517300	2	5.7
S6	PULSANTE DOPPIA VELOCITA'				
S5	INVERTITORE TRIPOLARE		518272	1	5.7
T1	TRASFORMATORE	100 VA	1296100	1	2.7
M1	MOTORE CENTRALINA	M.E.1.8-2.5T400 SX B3-B14 50HZ	900003880	1	3.7
M2	MOTORE MANDRINO	MEKW1.35/1.85T400/50B3G90L 450 2800/1400 RPM	900003930	1	3.7

REFERENCE	DESCRIPTION	TECHNICAL SPECIFICATIONS	CODE	QUANTITY	DOCUMENT REFERENCE
	CUT-OUT SWITCH 16A 3 POLES	ART.SE163003B 16A 3P BL/POR	518223	1	
	YELLOW/RED GIOVENZ KNOB	PADLOCK a.012/0001-1	518226	1	
KT1	TIMER RIT.DISECCIT.	TIMER RIT.DISECCIT. 12 240 AC DC	521104	1	
Q15	20A COMMUTATOR	20A C0013.09.11	518189	1	
F1	FUSE HOLDER	10,3x38 32A 690V 3 POLES SECTIONABLE	515035	1	
	FUSE	10,3x38 16A 500V aM DELAYED-ACTION	507045	3	
F2	OVERLOAD CUTOOUT SWITCH 6-10A	4-6.3A ART.GV2 ME14SCHNEIDER	518277	1	
				1	
F3-F4-F5	FUSE HOLDER	10,3x38 32A 690V 2 POLES SECTIONABLE	515027	2	
	FUSE	10,3X38 2A 500V RAPID	507019	3	
	FUSE	10.3X38 4A 500V	507097	1	
K1M-K2M-K3M-K4M-K5M	TRIPOLAR CONTACTOR	9A AC3 400V 4,2KW 1NC 24Vac 50/60Hz	522137	5	
	AUXILIARY CONTACTS BFX 10 11 1N0 1NC		522147	1	
	CLAMP 2.5mmq C/DIODO 1N4007		510218	10	
	CLAMP 2 PIAN.1.5mmq		510217	11	
	CLAMP G/V 4mmq ART.TEO.4 CABUR T0430 +PIASTR.TERM.TEO.4		510150 + 510209	3	
VC1	VC1BRIDGE	-	B1296200	1	
	C1-C2 CONTACTOR		B1296300	1	
	FEEDING CABLE ASSEMBLY			1	
	CHUCK UNIT MOTOR CABLE ASSEMBLY			1	
	HYDR. POWER UNIT MOTOR CABLE ASSEMBLY	-		1	
	HANDLE CABLE ASSEMBLY			1	
	SOLENOID VALVE CABLE ASSEMBLY Q1-Q2- Q3-Q4-Q5-Q6-Q7-Q8-Q11-Q12-Q13			1+1+1+1+1+1+ 1+1+1+1+1	
KA2 + BASE	RELAY 2 CONTACTS + 2 CONTACTS BASE	8A 24VAC	557017 + 557018	1 + 1	
S1/S2	HANDLE CONTROL	4 POS. + CENTRAL TEMPORARY Ø 22	517157AS	2	5.7
S4	BALANCING PUSHBUTTON	-	517300	2	5.7
S6	PUSHBUTTON DOUBLE SPEED				
S5	THREE-POLE INVERTER		518272	1	5.7
T1	TRANSFORMER	100 VA	1296100	1	2.7
M1	HYDRAULIC POWER UNIT MOTOR	M.E.1.8-2.5T400 SX B3-B14 50HZ	900003880	1	3.7
M2	MANDREL MOTOR	MEKW1.35/1.85T400/50B3G90L 450 2800/1400 RPM	900003930	1	3.7

INCOLLARE LA LINGUETTA DEL
MANIPOLATORE ALL'INTERNO
DELLA SCATOLA DELLA COLONNETTA

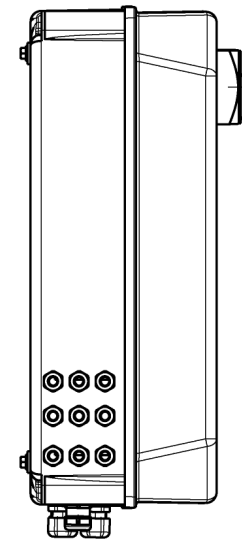
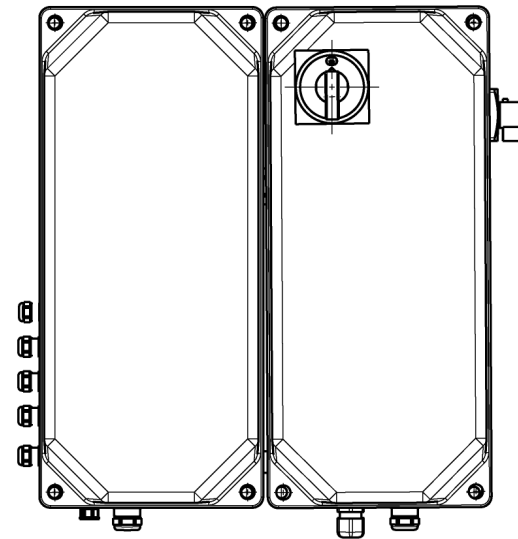
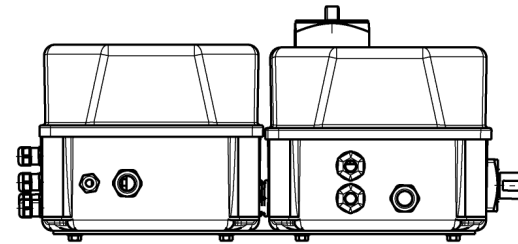
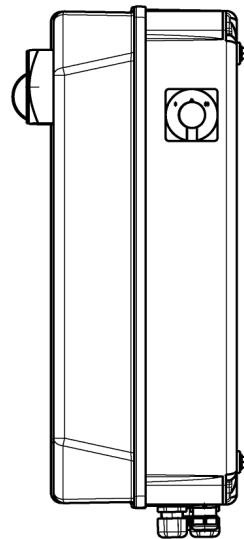
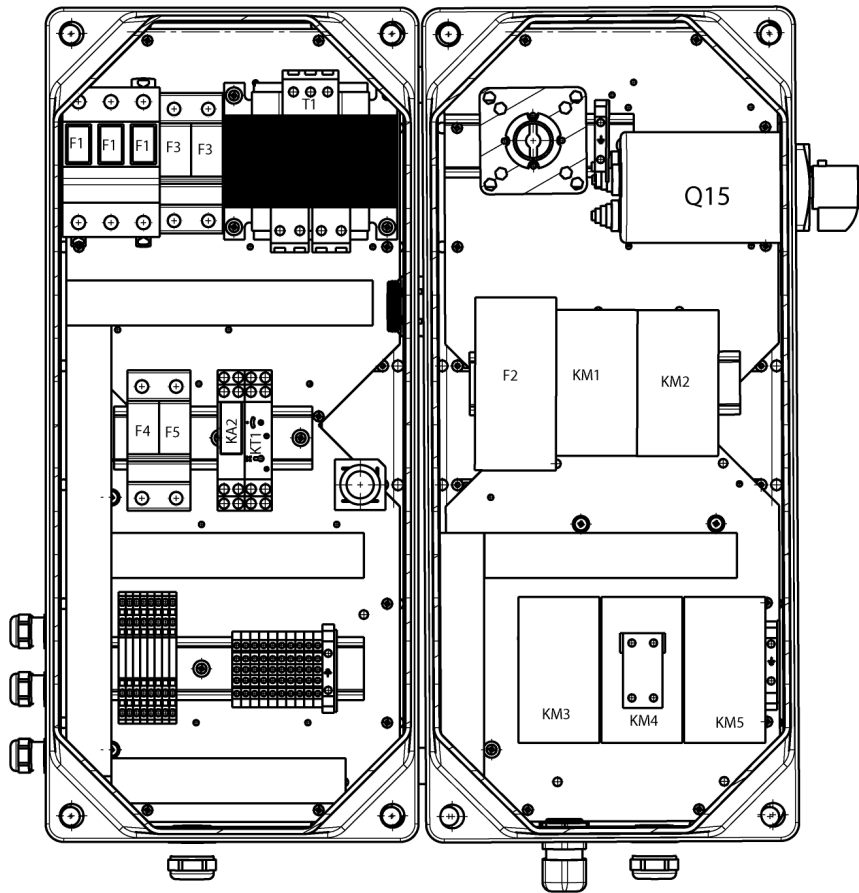
STICK THE HANDLE TANG INSIDE
THE COLUMN BOX

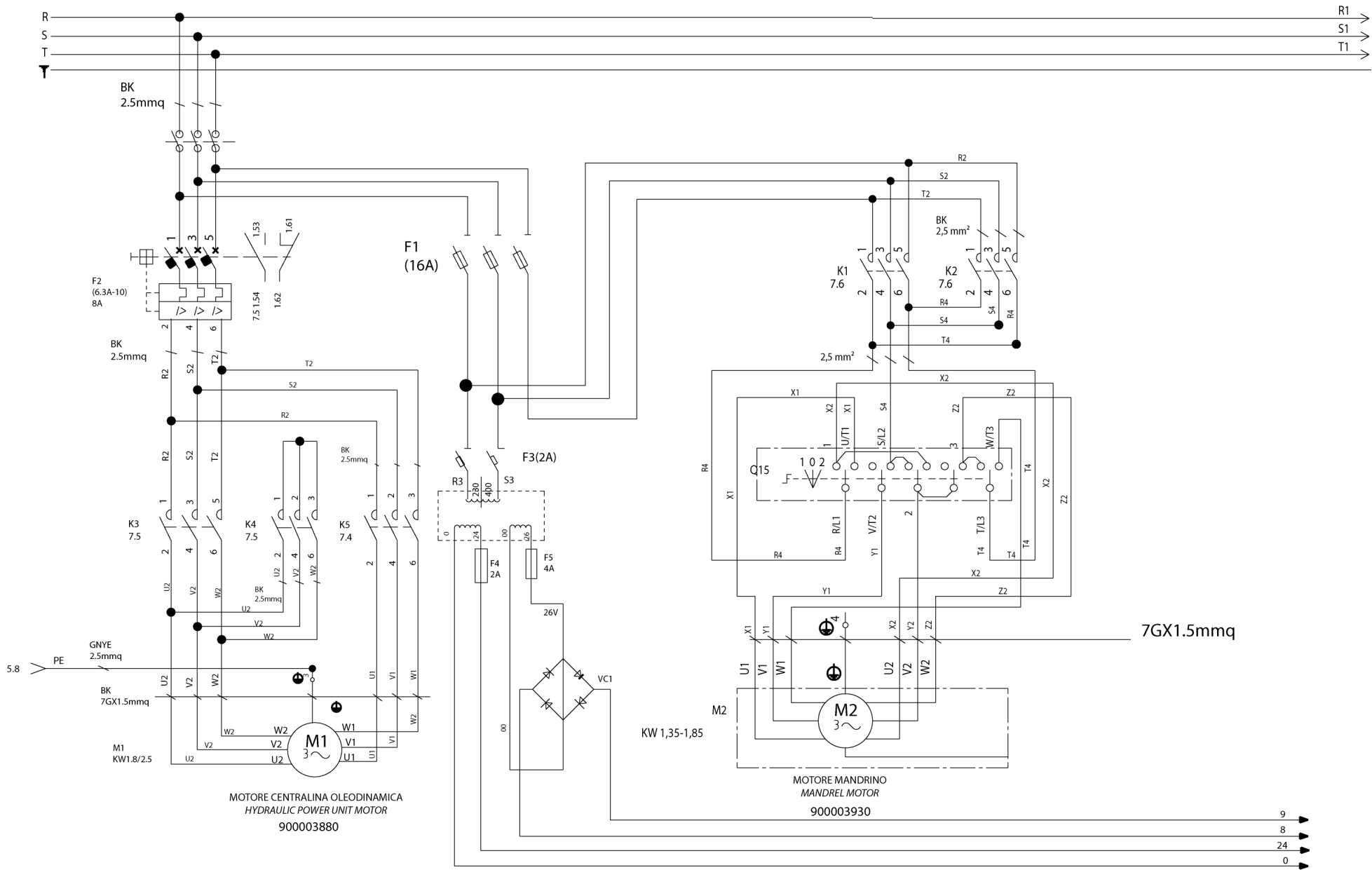


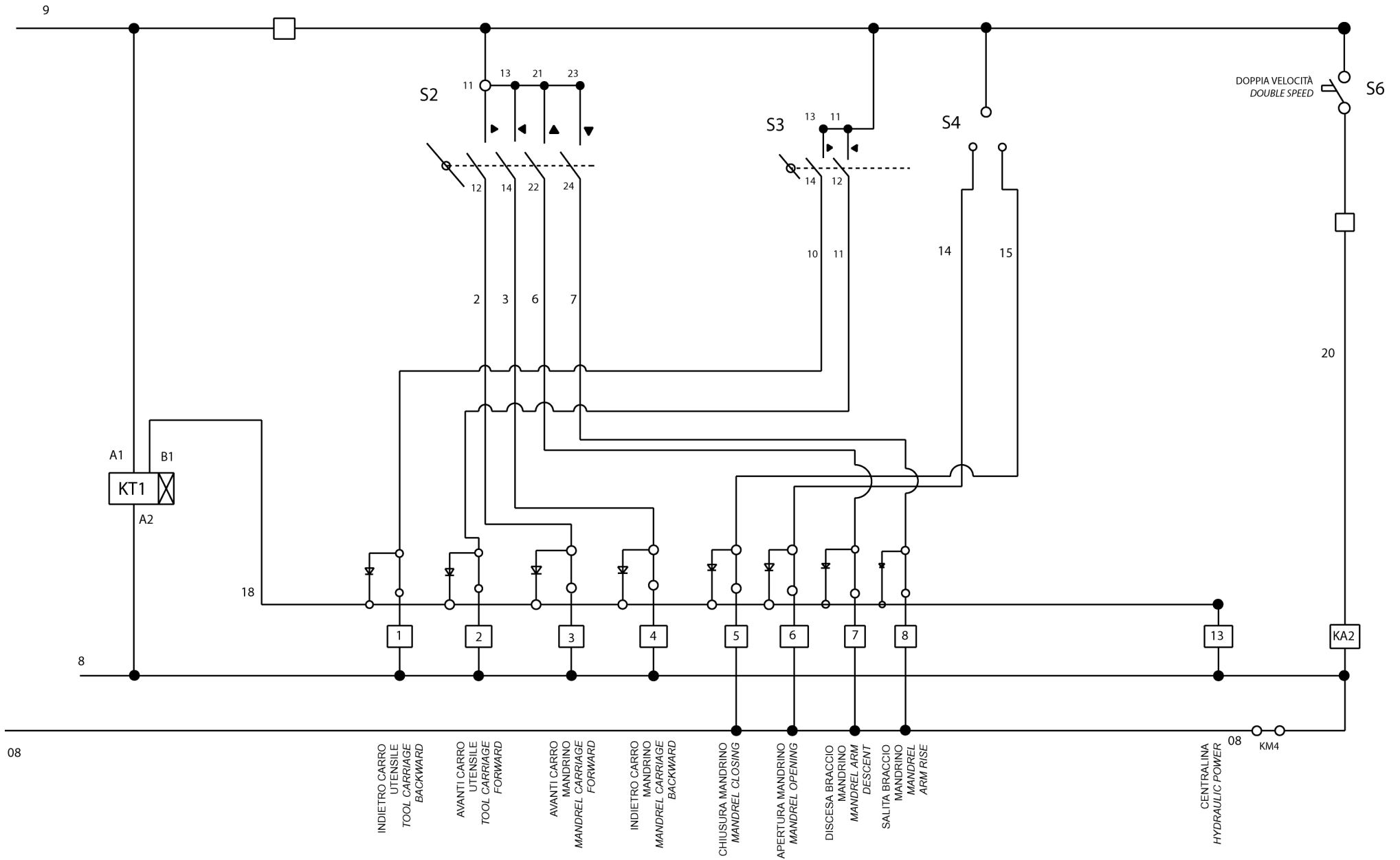
N.B. PER EVITARE CHE SI POSSANO SCOLLEGARE I CONTATTI
NEL CASO LA COLONNETTA COMANDI SUBISCA DEGLI URTI
INCOLLARE I CONTATTI AL MANIPOLATORE CON COLLA A CALDO

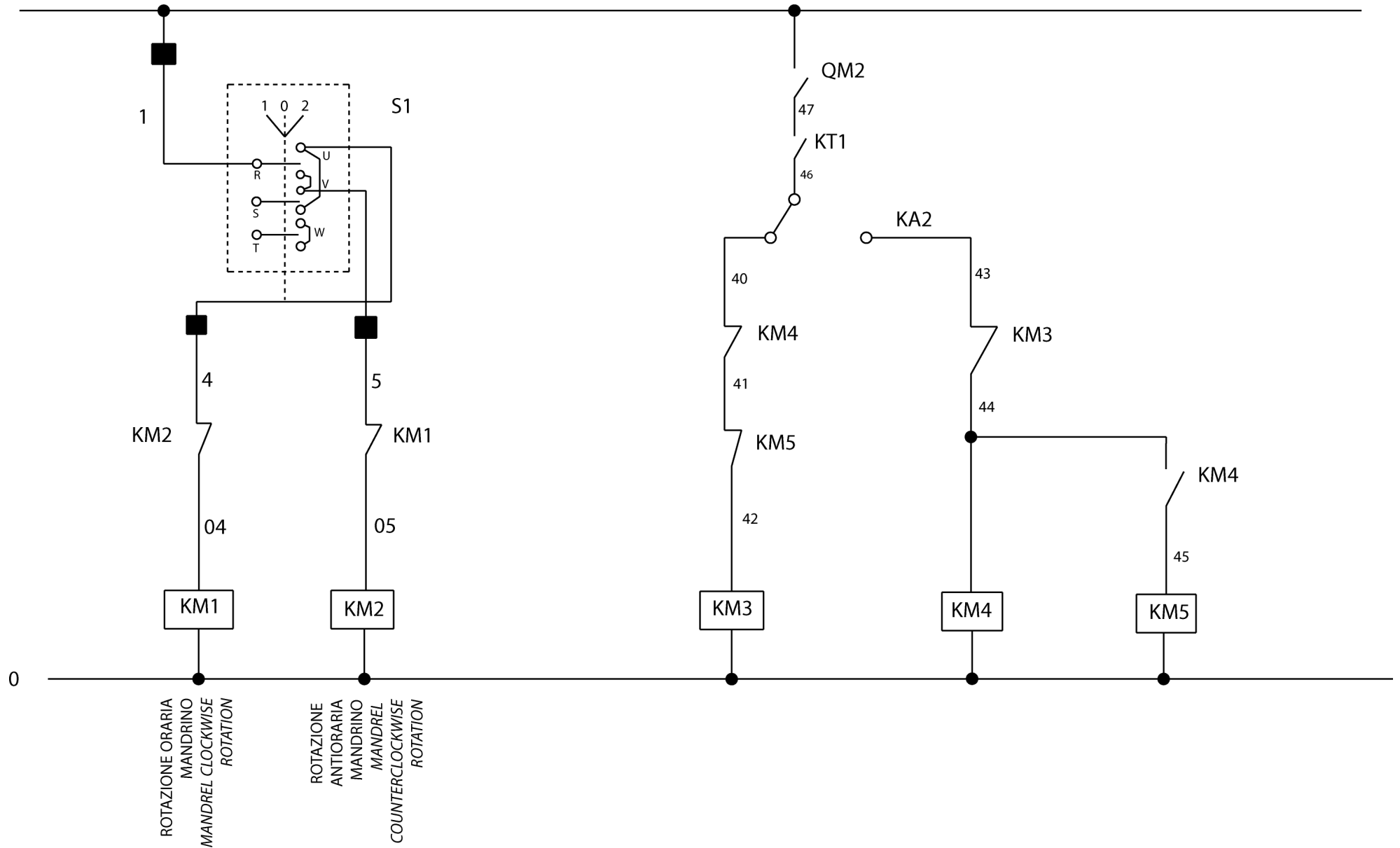
*N.B. TO AVOID THE CONTACTS DISCONNECTION
IN CASE OF COLLISIONS WITH THE CONTROLS STUD,
STICK THE CONTACTS ON THE HANDLE WITH HOT GLUE*

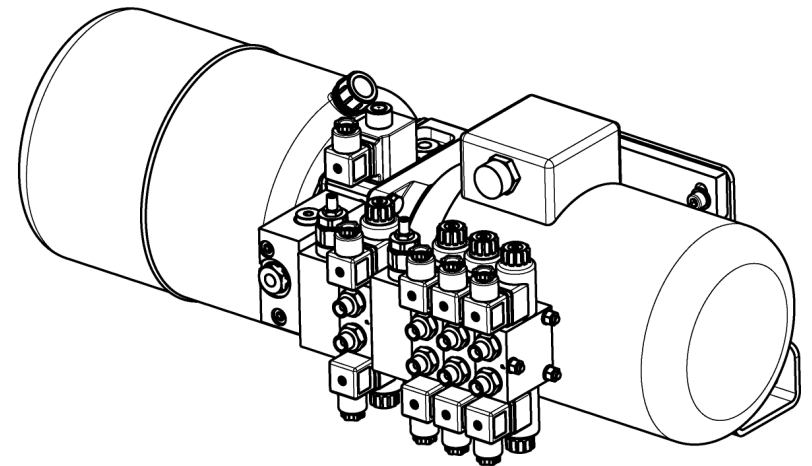
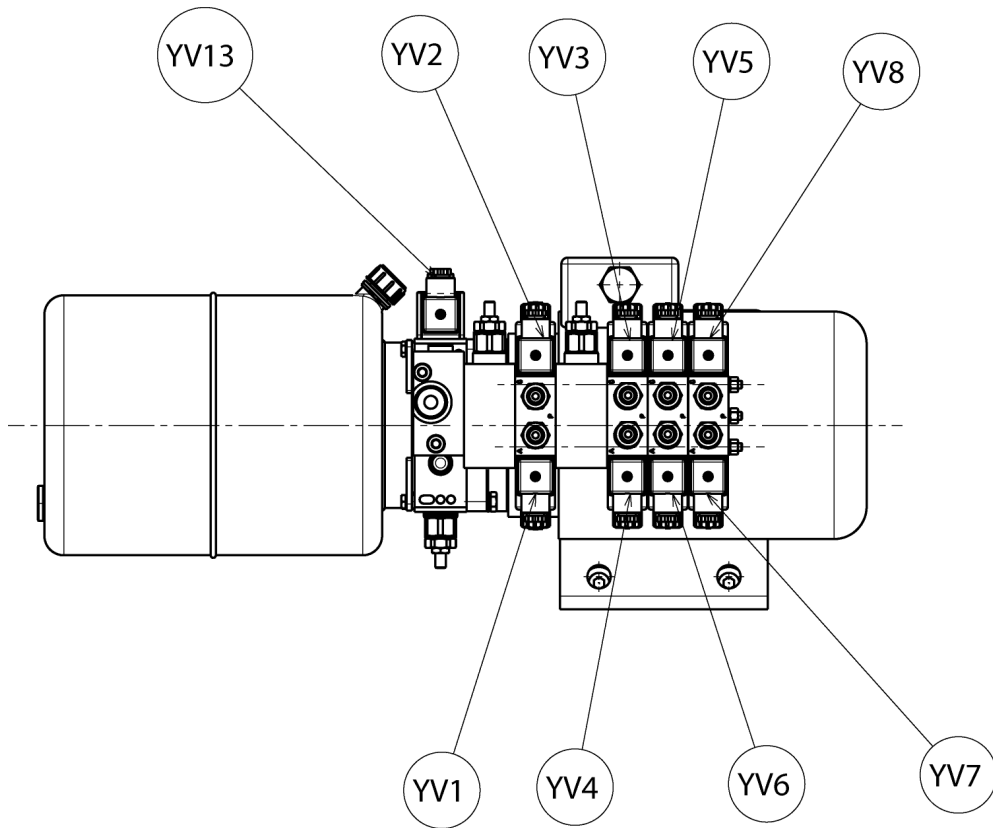
 RAVAGLIOLI S.p.A.	LISTA DEI COMPONENTI - LIST OF COMPONENTS - TEILELISTE LISTE DES PIÈCES DÉTACHÉES - LISTA DE PIEZAS		SCHEMA ELETTRICO (G9256.11SL - G9256.15SL) 9/9 ELECTRICAL SCHEME (G9256.11SL - G9256.15SL) 9/9 SCHALTPLAN (G9256.11SL - G9256.15SL) 9/9 SCHEMA ELECTRIQUE (G9256.11SL - G9256.15SL) 9/9 ESQUEMA ELECTRICO (G9256.11SL - G9256.15SL) 9/9	Pag. 62 di 168 <small>G9256.11SL - G9256.11ST - G9256.15 - G9256T.15 G9256A.15 - G9256D.15 - G9256TD.15 - G9256.15SL G10360.15 - G10360T.15 - G10360A.15 G10360D.15 - G10360TD.15</small>
	Tavola N°A - Rev. 2	752205800		



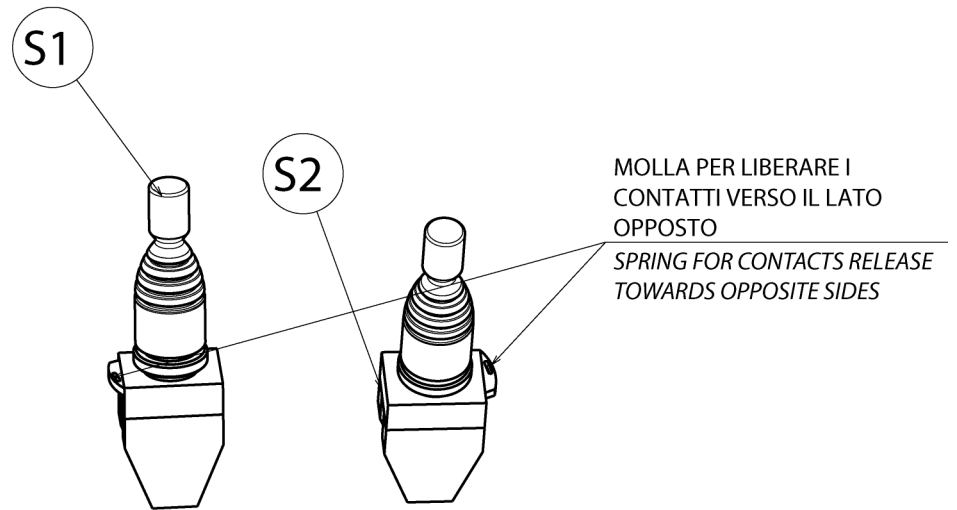
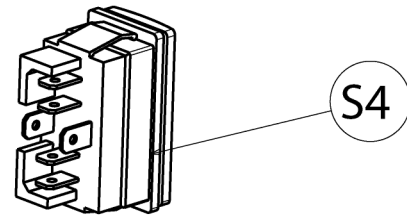
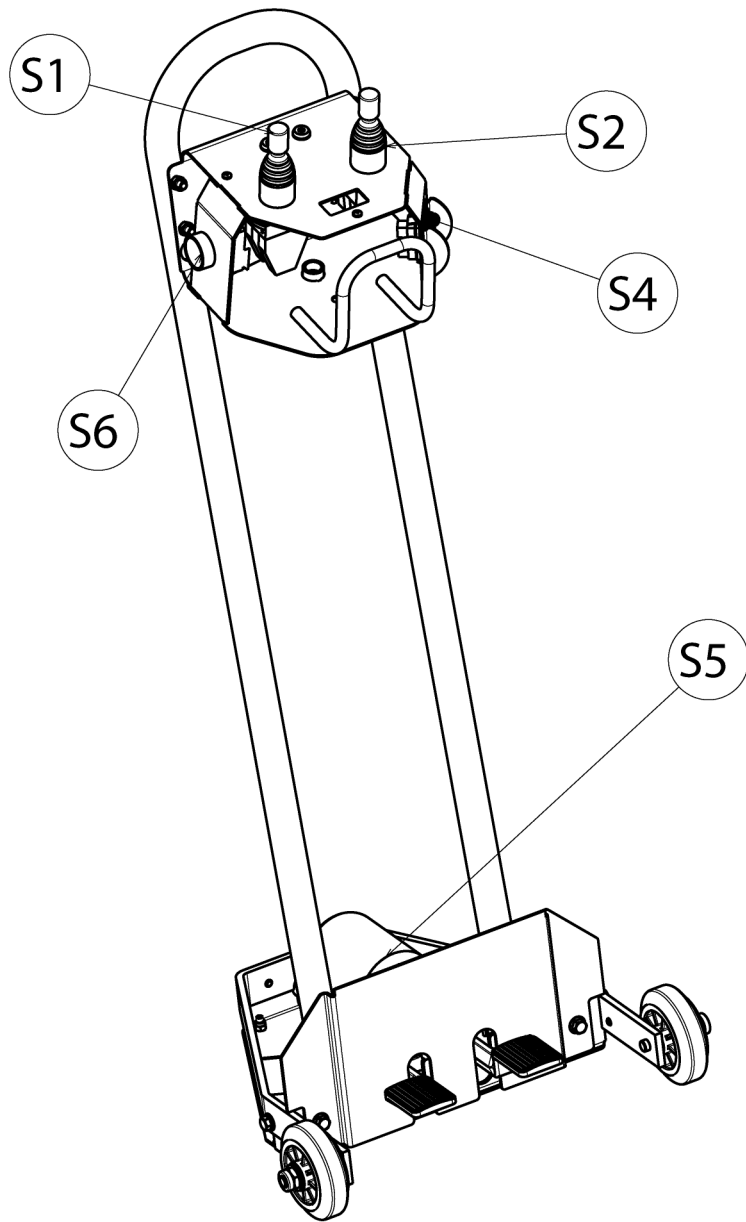








 RAVAGLIOLI S.p.A.	LISTA DEI COMPONENTI - LIST OF COMPONENTS - TEILELISTE LISTE DES PIÈCES DÉTACHÉES - LISTA DE PIEZAS		SCHEMA ELETTRICO (G9256.11ST) 5/9 ELECTRICAL SCHEME (G9256.11ST) 5/9 SCHALTPLAN (G9256.11ST) 5/9 SCHEMA ELECTRIQUE (G9256.11ST) 5/9 ESQUEMA ELECTRICO (G9256.11ST) 5/9	Pag. 67 di 168 <small>G9256.11SL - G9256.11ST - G9256.15 - G9256T.15 G9256A.15 - G9256D.15 - G9256TD.15 - G9256.15SL G10360.15 - G10360T.15 - G10360A.15 G10360D.15 - G10360TD.15</small>
	Tavola N°B - Rev. 2	752205810		



RIFERIMENTO	DESCRIZIONE	DATI TECNICI	CODICE	QUANTITA	RIFERIMENTO DOCUMENTO
	SEZIONATORE 16A 3 POLI	ART.SE163003B 16A 3P BL/POR	518223	1	
	MANOPOLA GIALLO/ROSSA GIOVENZ	a.012/0001-1 LUCCHETTO	518226	1	
KT1	TIMER RIT.DISECCIT.	TIMER RIT.DISECCIT. 12 240 AC DC	521104	1	
Q15	COMMUTATORE 20A	20A C0013.09.11	518189	1	
F1	PORTAFUSIBILE	3 POLI SEZIONABILE 10,3x38 32A 690V	515035	1	
	FUSIBILE	10,3x38 16A 500V aM RITARDATO	507045	3	
F2	INTERRUTT.6-10A SLVAMOTORE	4-6.3A ART.GV2 ME14SCHNEIDER	518277	1	
				1	
F3-F4-F5	PORTAFUSIBILE	2 POLI SEZIONABILE 10,3x38 32A 690V	515027	2	
	FUSIBILE	10,3X38 2A 500V RAPIDO	507019	3	
	FUSIBILE	GL10.3X38 4A 500V	507097	1	
K1M-K2M-K3M-K4M-K5M	CONTATTORE TRIPOLARE	9A AC3 400V 4,2KW 1NC 24Vac 50/60Hz	522137	5	
	CONTATTI AUSILIARI BFX 10 11 1NO 1NC		522147	1	
	MORSETTO 2.5mmq C/DIODO 1N4007		510218	8	
	MORSETTO A MOLLA 2 PIAN.1.5mmq		510217	10	
	MORSETTO G/V 4mmq ART.TEO.4 CABUR T0430 +PIASTR.TERM.TEO.4		510150 + 510209	3	
VC1	PONTE RADDRIZZATORE VC1	-	B1296200	1	
	CONDENSATORE C1-C2		B1296300	1	
	INS.CAVO ALIMENTAZIONE QUADRO			1	
	INS.CAVO MOTORE MANDRINO			1	
	INS.CAVO MOTORE CENTRALINA	-		1	
	INS.CAVO MANIPOLATORE			1	
	INS.CAVO ELETTROVALV.Q1-Q2- Q3-Q4-Q5-Q6-Q8-Q13			1+1+1+1+1+1+ 1	
KA2 + ZOCOLO	RELE'A 2 CONTATTI + ZOCOLO A 2 CONTATTI	8A 24VAC	557017 + 557018	1 + 1	
S1	MANIPOLATORE	4 POS.+CENTR.TEMPORANEE Ø22	517157AS	1	5.7
S2	MANIPOLATORE	2 PèOS.+CENTR.TEMPORANEE Ø22	517156AS	1	
S4	PULSANTE BASCULANTE	-	517300	1	5.7
S6	PULSANTE DOPPIA VELOCITA'				
S5	INVERTITORE TRIPOLARE		518272	1	5.7
T1	TRASFORMATORE	100 VA	1296100	1	2.7
M1	MOTORE CENTRALINA	M.E.1.8-2.5T400 SX B3-B14 50HZ	900003880	1	3.7
M2	MOTORE MANDRINO	MEKW1.35/1.85T400/50B3G90L 450 2800/1400 RPM	900003930	1	3.7

REFERENCE	DESCRIPTION	TECHNICAL SPECIFICATIONS	CODE	QUANTITY	DOCUMENT REFERENCE
	CUT-OUT SWITCH 16A 3 POLES	ART.SE163003B 16A 3P BL/POR	518223	1	
	YELLOW/RED GIOVENZ KNOB	PADLOCK a.012/0001-1	518226	1	
KT1	TIMER RIT.DISECCIT.	TIMER RIT.DISECCIT. 12 240 AC DC	521104	1	
Q15	20A COMMUTATOR	20A C0013.09.11	518189	1	
F1	FUSE HOLDER	10,3x38 32A 690V 3 POLES SECTIONABLE	515035	1	
	FUSE	10,3x38 16A 500V aM DELAYED-ACTION	507045	3	
F2	OVERLOAD CUTOUT SWITCH 6-10A	4-6.3A ART.GV2 ME14SCHNEIDER	518277	1	
				1	
F3-F4-F5	FUSE HOLDER	10,3x38 32A 690V 2 POLES SECTIONABLE	515027	2	
	FUSE	10,3X38 2A 500V RAPID	507019	3	
	FUSE	GL10.3X38 4A 500V	507097	1	
K1M-K2M-K3M-K4M-K5M	TRIPOLAR CONTACTOR	9A AC3 400V 4,2KW 1NC 24Vac 50/60Hz	522137	5	
	AUXILIARY CONTACTS BFX 10 11 1NO 1NC		522147	1	
	CLAMP 2.5mmq C/DIODO 1N4007		510218	8	
	CLAMP 2 PIAN.1.5mmq		510217	10	
	CLAMP G/V 4mmq ART.TEO.4 CABUR T0430 +PIASTR.TERM.TEO.4		510150 + 510209	3	
VC1	VC1BRIDGE	-	B1296200	1	
	C1-C2 CONTACTOR		B1296300	1	
	FEEDING CABLE ASSEMBLY			1	
	CHUCK UNIT MOTOR CABLE ASSEMBLY			1	
	HYDR. POWER UNIT MOTOR CABLE ASSEMBLY	-		1	
	HANDLE CABLE ASSEMBLY			1	
	SOLENOID VALVE CABLE ASSEMBLY Q1-Q2- Q3-Q4-Q5-Q6-Q7-Q8-Q11-Q12-Q13			1+1+1+1+1+1+ 1+1+1+1+1	
KA2 + BASE	RELAY 2 CONTACTS + 2 CONTACTS BASE	8A 24VAC	557017 + 557018	1 + 1	
S1	HANDLE CONTROL		517157AS	1	5.7
S2	HANDLE CONTROL	4 POS. + CENTRAL TEMPORARY Ø 22	517156AS	1	
S4	BALANCING PUSHBUTTON	2 POS. + CENTRAL TEMPORARY Ø 22	517300	1	5.7
S6	PUSHBUTTON DOUBLE SPEED				
S5	THREE-POLE INVERTER		518272	1	5.7
T1	TRANSFORMER	100 VA	1296100	1	2.7
M1	HYDRAULIC POWER UNIT MOTOR	M.E.1.8-2.5T400 SX B3-B14 50HZ	900003880	1	3.7
M2	MANDREL MOTOR	MEKW1.35/1.85T400/50B3G90L 450 2800/1400 RPM	900003930	1	3.7

INCOLLARE LA LINGUETTA DEL
MANIPOLATORE ALL'INTERNO
DELLA SCATOLA DELLA COLONNETTA

STICK THE HANDLE TANG INSIDE
THE COLUMN BOX



N.B. PER EVITARE CHE SI POSSANO SCOLLEGARE I CONTATTI
NEL CASO LA COLONNETTA COMANDI SUBISCA DEGLI URTI
INCOLLARE I CONTATTI AL MANIPOLATORE CON COLLA A CALDO

N.B. TO AVOID THE CONTACTS DISCONNECTION
IN CASE OF COLLISIONS WITH THE CONTROLS STUD,
STICK THE CONTACTS ON THE HANDLE WITH HOT GLUE



RAVAGLIOLI S.p.A.

LISTA DEI COMPONENTI - LIST OF COMPONENTS - TEILELISTE
LISTE DES PIÈCES DÉTACHÉES - LISTA DE PIEZAS

Tavola N°B - Rev. 2

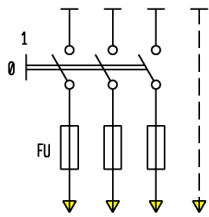
752205810

SCHEMA ELETTRICO (G9256.11ST) 9/9
ELECTRICAL SCHEME (G9256.11ST) 9/9
SCHALTPLAN (G9256.11ST) 9/9
SCHEMA ELECTRIQUE (G9256.11ST) 9/9
ESQUEMA ELECTRICO (G9256.11ST) 9/9

Pag. 71 di 168

G9256.11SL - G9256.11ST - G9256.15 - G9256T.15
G9256A.15 - G9256D.15 - G9256TD.15 - G9256.15SL
G10360.15 - G10360T.15 - G10360A.15
G10360D.15 - G10360TD.15

7522-M001-14_R



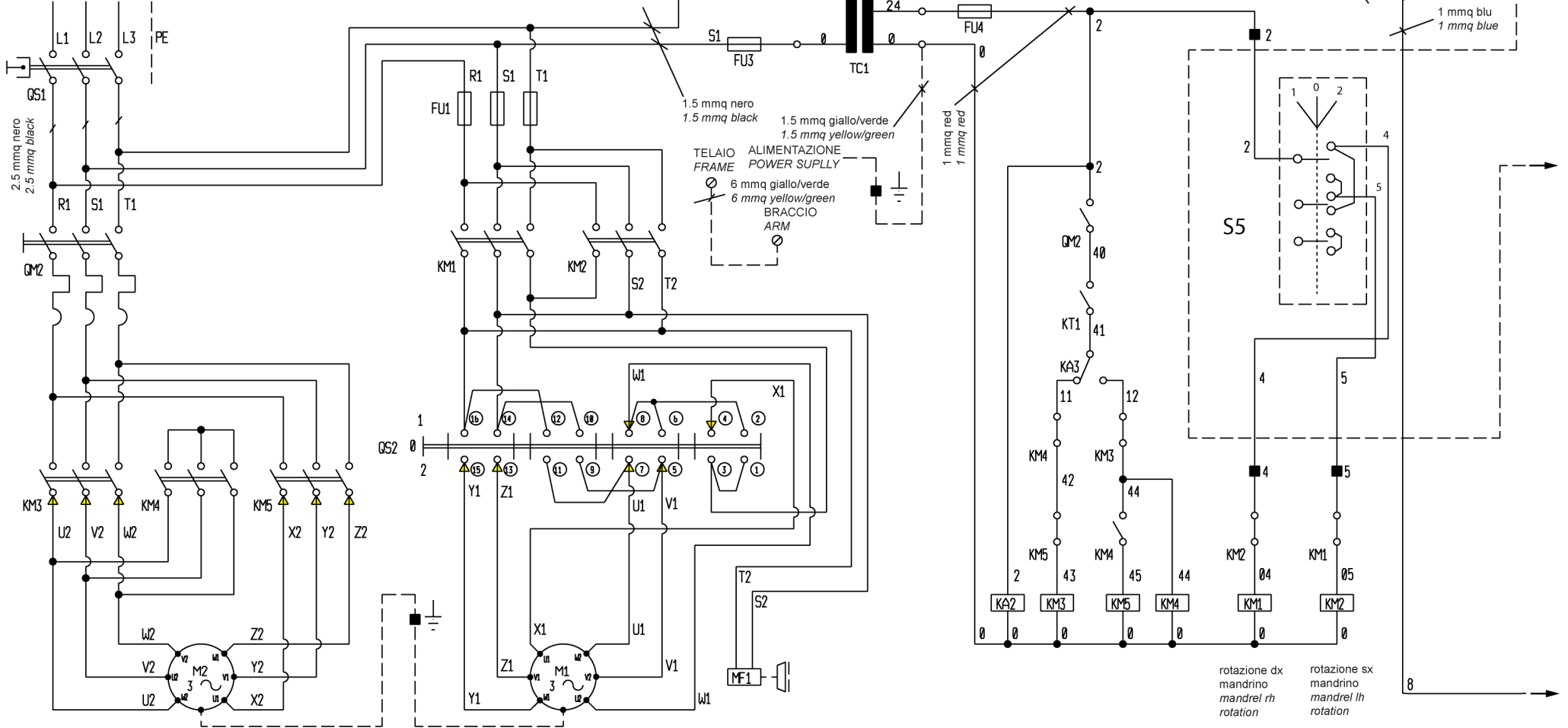
INSTALLAZIONE A CARICO DEL CLIENTE
INSTALLATION TO BE MADE BY THE USER

FU	V	
	230	400
50	16A aM	10A aM
60	16A aM	10A aM

CAVO D'ALIMENTAZIONE 3P + TERRA x 2.5 mmq
SUPPLY CABLE 3P + GROUND x 2.5 mmq

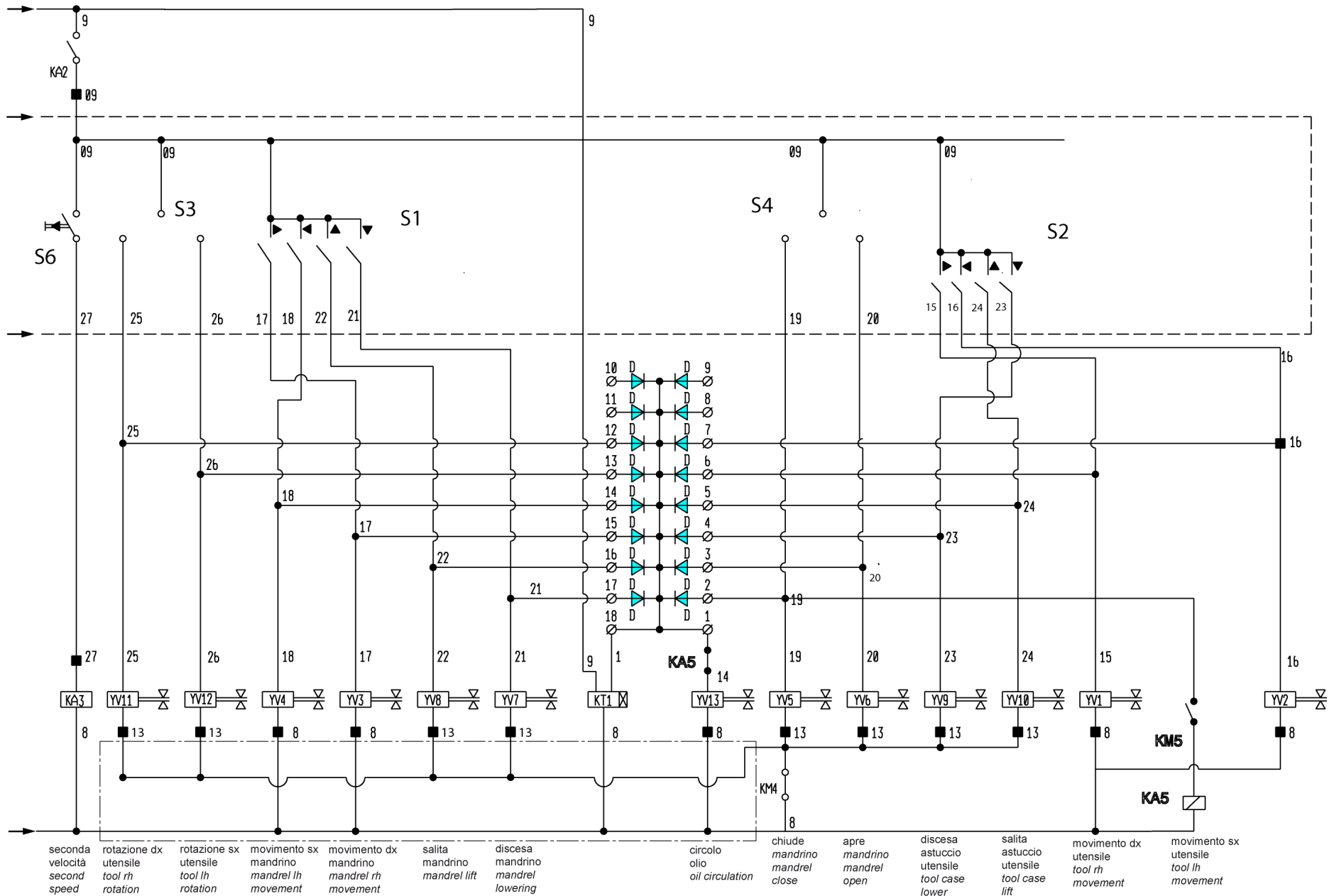
MORSETTI QS2
CLAMP QS2
16 = S/L2
14 = R/L1
3 = T/L3
15 = V/T2
13 = U/T1
4 = W/T3
7 = 2
5 = 1
8 = 3

MORSETTI IRM
CLAMP IRM
11 = T/L3
7 = S/L2
3 = R/L1
12 = W
8 = V
2 = U



rotazione dx
mandrino
mandrel rh
rotation

rotazione sx
mandrino
mandrel lh
rotation



RAVAGLIOLI S.p.A.

LISTA DEI COMPONENTI - LIST OF COMPONENTS - TEILELISTE
LISTE DES PIÈCES DÉTACHÉES - LISTA DE PIEZAS

Tavola N°C - Rev. 3

752205780

SCHEMA ELETTRICO 2/4
 ELECTRICAL SCHEME 2/4
 SCHALTPLAN 2/4

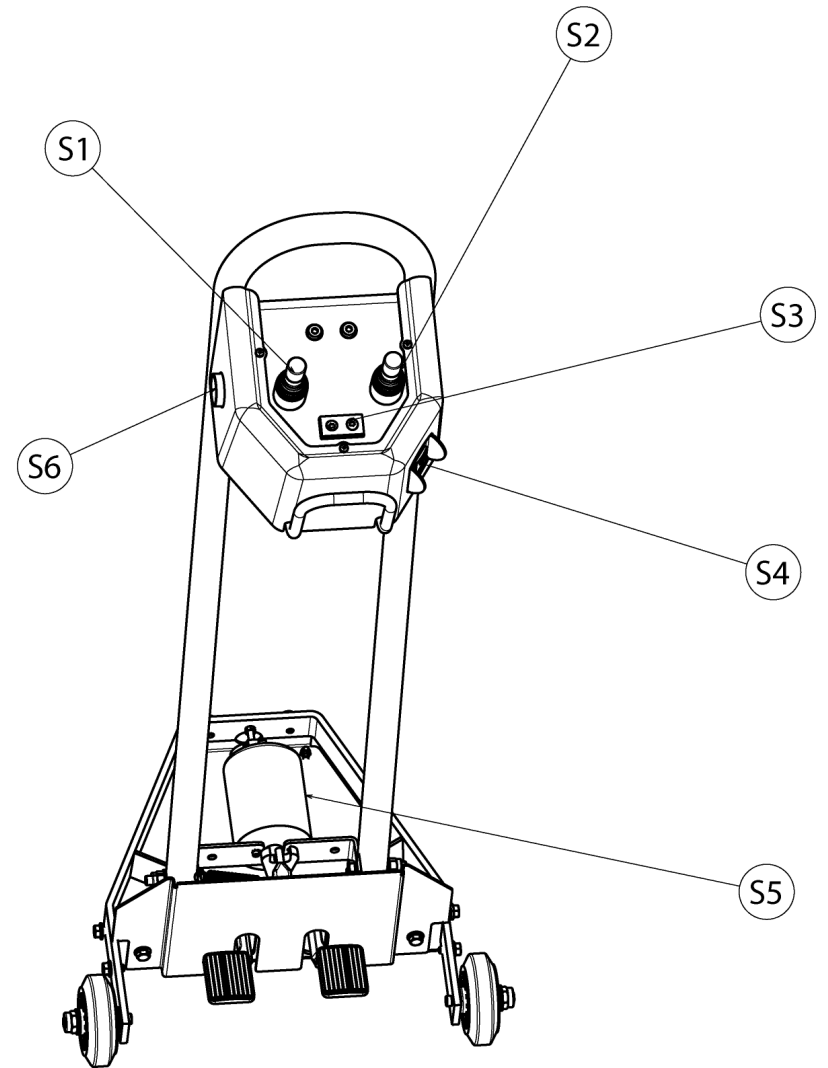
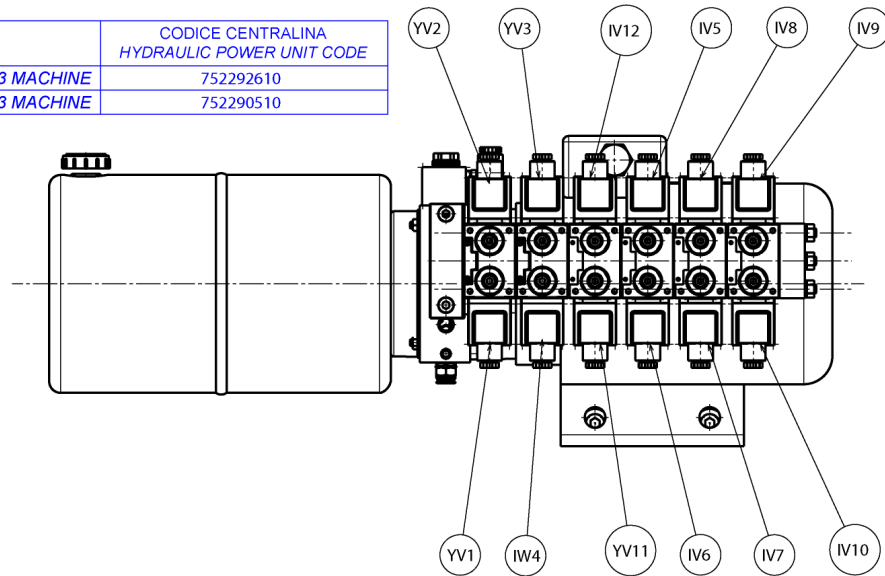
SCHEMA ELECTRIQUE 2/4
 ESQUEMA ELECTRICO 2/4

(G9256.15 - G9256T.15 - G10360.15 - G10360T.15)

Pag. 73 di 168

G9256.11SL - G9256.11ST - G9256.15 - G9256T.15
 G9256A.15 - G9256D.15 - G9256TD.15 - G9256.15SL
 G10360.15 - G10360T.15 - G10360A.15
 G10360D.15 - G10360TD.15

	CODICE CENTRALINA HYDRAULIC POWER UNIT CODE
MACCHINE NAV63/ NAV63 MACHINE	752292610
MACCHINE NAV43/ NAV43 MACHINE	752290510





RAVAGLIOLI S.p.A.

LISTA DEI COMPONENTI - LIST OF COMPONENTS - TEILELISTE
LISTE DES PIÈCES DÉTACHÉES - LISTA DE PIEZAS

Tavola N°C - Rev. 3

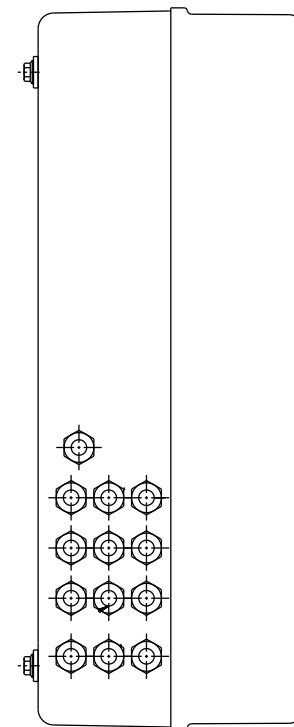
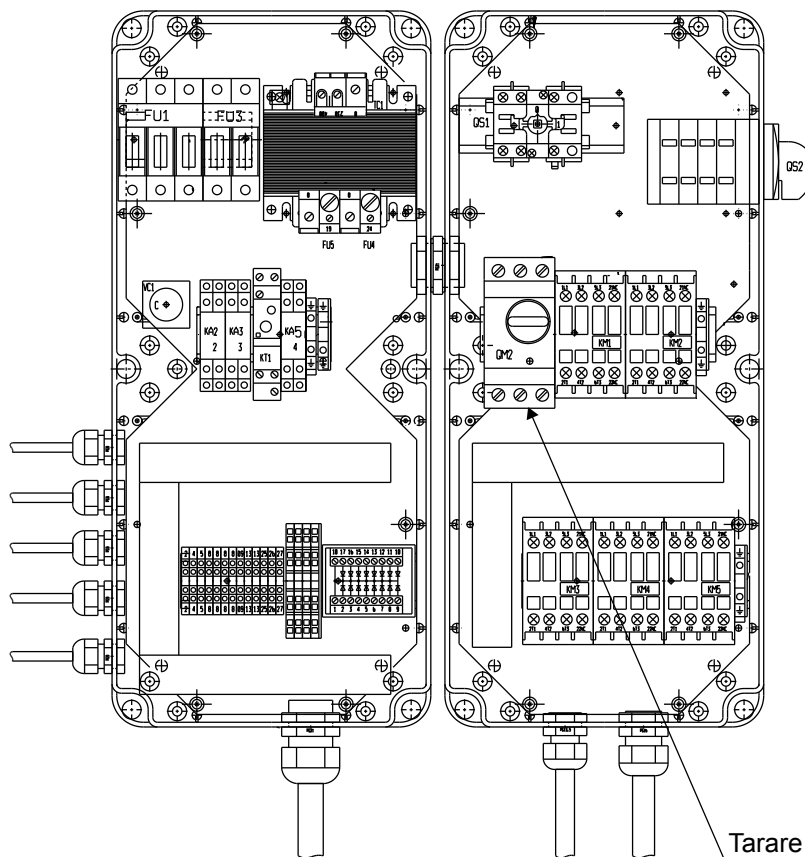
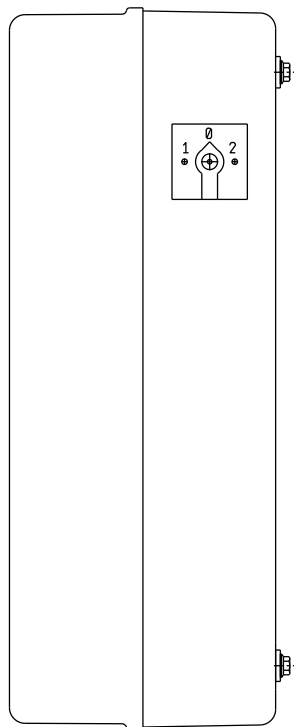
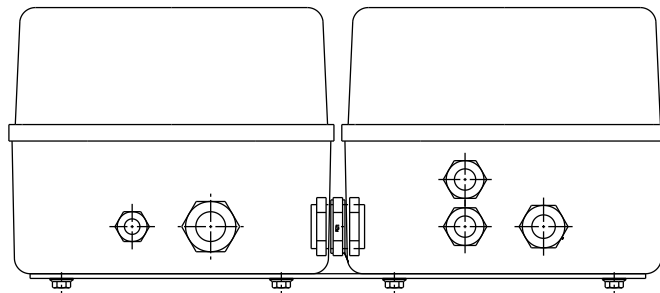
752205780

SCHEMA ELETTRICO 4/4
ELECTRICAL SCHEME 4/4
SCHALTPLAN 4/4
SCHEMA ELECTRIQUE 4/4
ESQUEMA ELECTRICO 4/4
(G9256.15 - G9256T.15 - G10360.15 - G10360T.15)

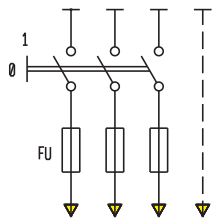
Pag. 75 di 168

G9256.11SL - G9256.11ST - G9256.15 - G9256T.15
G9256A.15 - G9256D.15 - G9256TD.15 - G9256.115SL
G10360.15 - G10360T.15 - G10360A.15
G10360D.15 - G10360TD.15

N°	Cod.	Descrizione	Description
	C	Condensatore elettrolitico	Electrolytic condenser
	D	Diode 1N4007	1N4007 diode
	FU1	Fusibile protezione linea	Line guard fuse
	FU3	Fusibile protezione primario	First guard fuse
	FU4	Fusibile protezione secondario	Second guard fuse
	FU5	Fusibile protezione secondario	Second guard fuse
	KA2	Relè blocco comandi	Controls block relay
	KA3	Relè comando seconda velocità	Relay commande second speed
	KA5	Relè inibitore elettrovalvola in seconda velocità	Second speed solenoid valve inhibitor relay
	KM1	Contattore rotazione oraria mandrino	Chuck clockwise rot. Contactor
	KM2	Contattore rotazione antioraria mandrino	Chuck anticlockwise rot. Contactor
	KM3	Contattore comando prima velocità	First speed control contactor
	KM4/KM5	Contattore comando seconda velocità	Second speed control contactor
	KT1	Timer comando motore centralina	Hydraulic power unit control timer
	MF1	Freno motore mandrino	Chuck motor brake
	S5	Commutatore comando rotazione mandrino	Mandrel rotation control commutator
	S2	Manipolatore comando carro utensile avanti/indietro e salita/discesa	Handle for tool carriage forward/backward control
	S1	Manipolatore comando salita/discesa mandrino e movimento sx/movimento dx mandrino	Handle for mandrel up/down control handle and mandrel lh/rh movement
	M1	Motore mandrino	Chuck motor
	M2	Motore centralina	Hydraulic power unit motor
	QM2	Interruttore magnetotermico	Magnetic-thermique switch
	QS1	Interruttore generale	Main switch
	QS2	Commutatore di poli	Pole commutator
	S4	Pulsante apre/chiude mandrino	Mandrel open/close push-button
	S3	Pulsante comando rotazione utensili dx/sx	Rh/lh tools rotation control push-button
	S6	Pulsante seconda velocità centralina	Hydraulic power unit second speed push-button
	TC1	Trasformatore comandi	Control transformer
	VC1	Ponte raddrizzatore	Bridge
	YV1	Elettrovalvola movimento dx utensile	Tool rh movement solenoid valve
	YV2	Elettrovalvola movimento sx utensile	Tool lh movement solenoid valve
	YV3	Elettrovalvola movimento dx mandrino	Chuck rh movement solenoid valve
	YV4	Elettrovalvola movimento sx mandrino	Chuck lh movement solenoid valve
	YV5	Elettrovalvola chiude mandrino	Chuck closing solenoid valve
	YV6	Elettrovalvola apre mandrino	Chuck opening solenoid valve
	YV7	Elettrovalvola discesa mandrino	Chuck descent solenoid valve
	YV8	Elettrovalvola salita mandrino	Chuck rising solenoid valve
	YV9	Elettrovalvola entra utensile	Tool "in" solenoid valve
	YV10	Elettrovalvola esce utensile	Tool "out" solenoid valve
	YV11	Elettrovalvola rotazione Synodx	Rotation solenoid valve Synodx
	YV12	Elettrovalvola rotazione Synosx	Synosx rotation solenoid valve
	YV13	Elettrovalvola circolo olio	Oil circulation solenoid valve
	■	Morsetto	Morsetto



Tarare il salvatore a 8A
Set the overload cut out at 8A

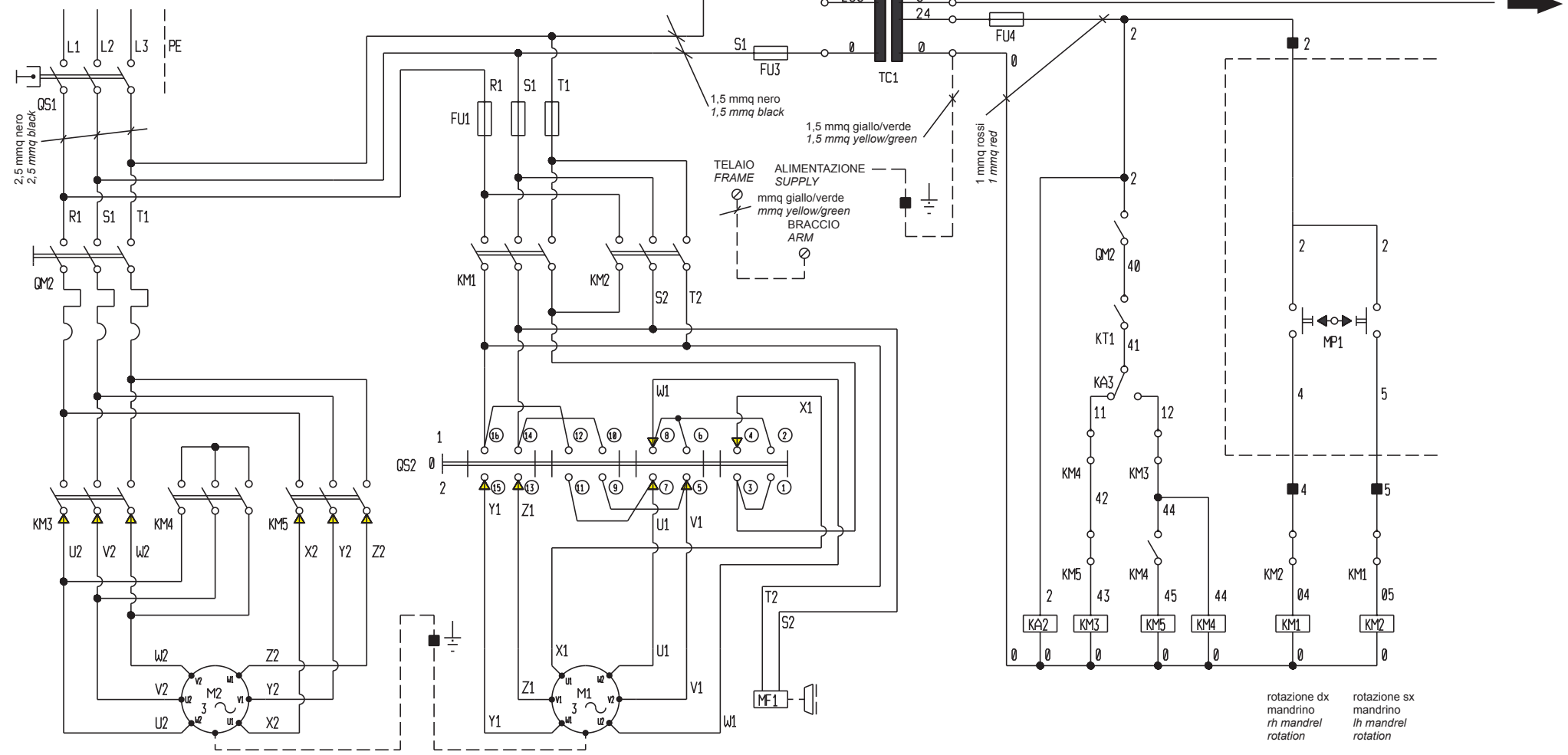


INSTALLAZIONE A CARICO DEL CLIENTE
INSTALLATION TO BE MADE BY THE USER

FU	V	230	400
		HZ	
50		16A aM	10A aM
60		16A aM	10A aM

CAVO ALIMENTAZIONE 3P + TERRA x 2,5 mmq
SUPPLY CABLE 3P + GROUND x 2,5 mmq

- MORSETTI QS2
QS2 TERMINALS
- 16 = S/L2
 - 14 = R/L1
 - 3 = T/L3
 - 15 = V/T2
 - 13 = U/T1
 - 4 = W/T3
 - 7 = 2
 - 5 = 1
 - 8 = 3
- MORSETTI IRM
IRM TERMINALS
- 11 = T/L3
 - 7 = S/L2
 - 3 = R/L1
 - 12 = W
 - 8 = V
 - 2 = U



rotazione dx mandrino
rh mandrel rotation

rotazione sx mandrino
lh mandrel rotation



LISTA DEI COMPONENTI - LIST OF COMPONENTS - TEILELISTE
LISTE DES PIÈCES DÉTACHÉES - LISTA DE PIEZAS

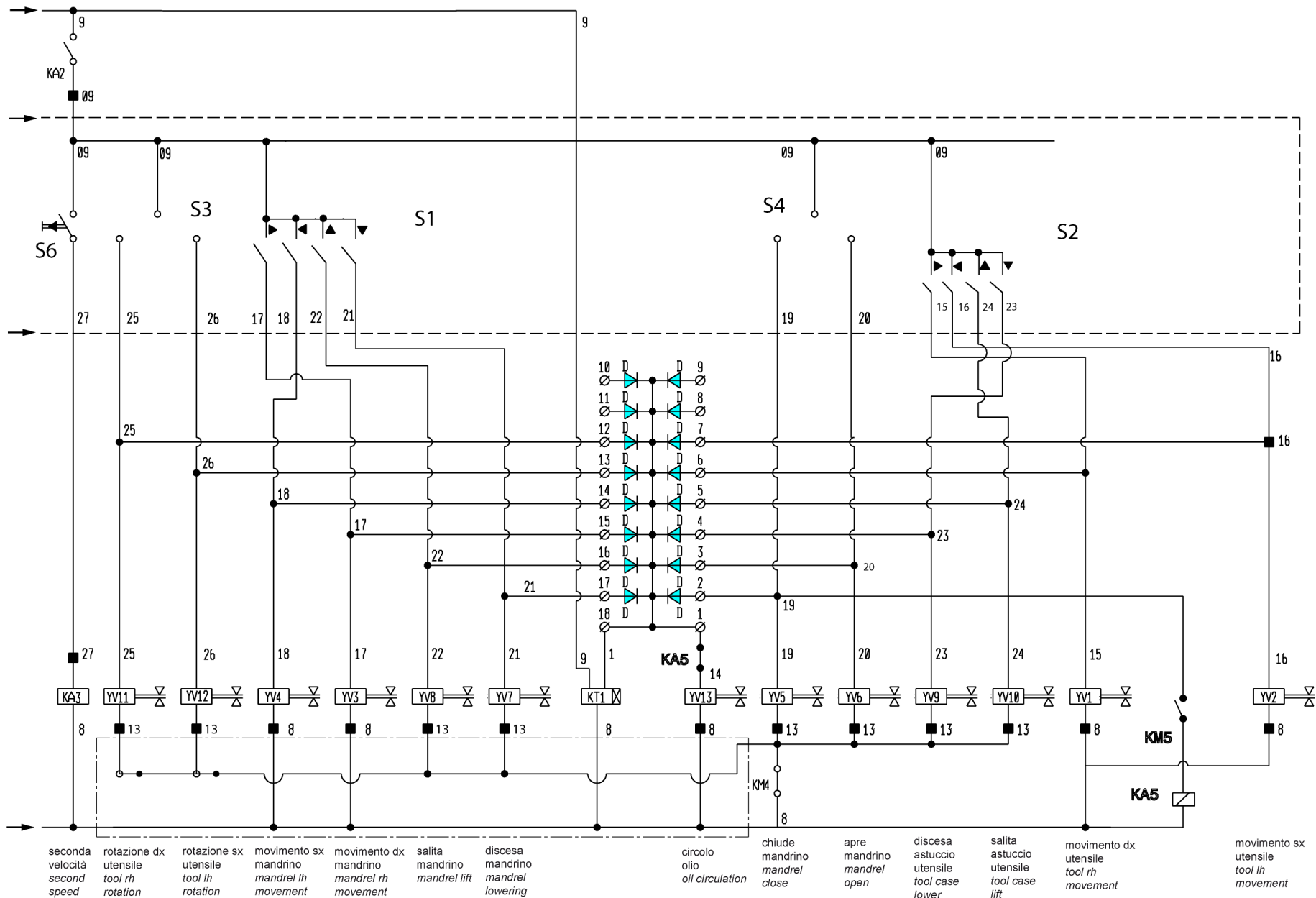
Tavola N°D - Rev. 2

752205660

SCHEMA ELETTRICO 2/3
ELECTRICAL SCHEME 2/3
SCHALTPLAN 2/3
SCHEMA ELECTRIQUE 2/3
ESQUEMA ELECTRICO 2/3
(G9256A.15 - G10360A.15) (VARGNAV43A) (VARGNAV63A.15)

Pag. 77 di 168

G9256.11SL - G9256.11ST - G9256.15 - G9256T.15
G9256A.15 - G9256D.15 - G9256TD.15 - G9256.15SL
G10360.15 - G10360T.15 - G10360A.15
G10360D.15 - G10360TD.15



RAVAGLIOLI S.p.A.

**LISTA DEI COMPONENTI - LIST OF COMPONENTS - TEILELISTE
LISTE DES PIÈCES DÉTACHÉES - LISTA DE PIEZAS**

Tavola N°E - Rev. 2

752205820

SCHEMA ELETTRICO 2/4
ELECTRICAL SCHEME 2/4
SCHALTPLAN 2/4

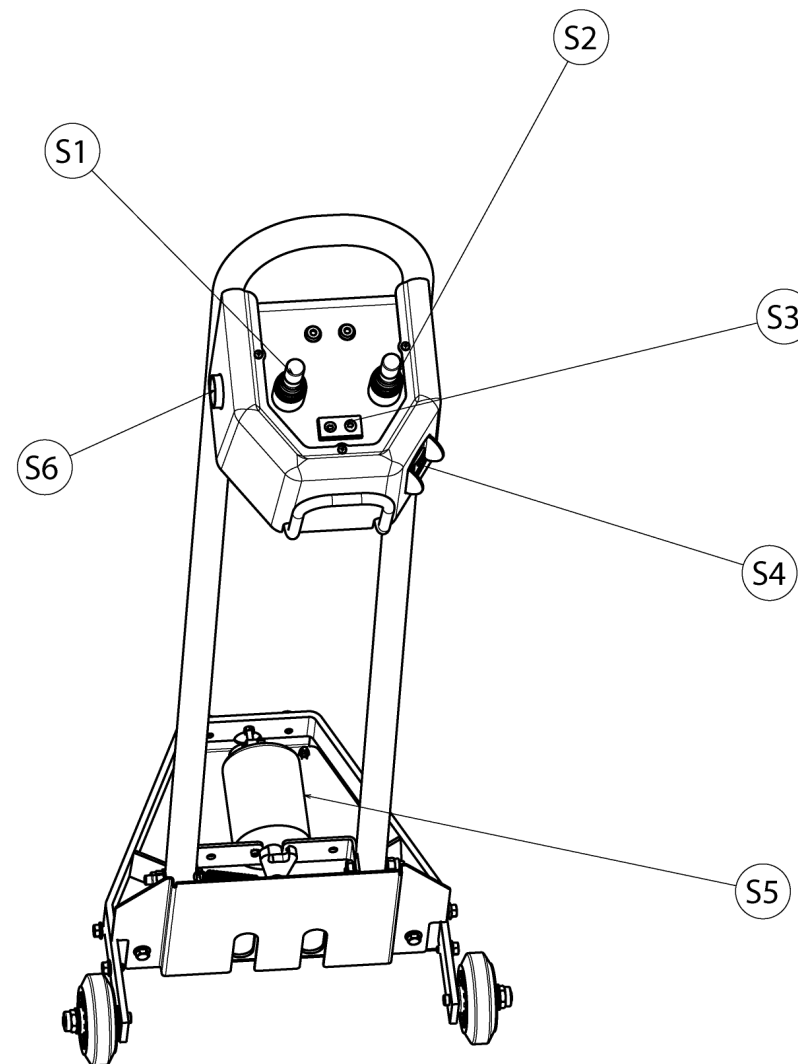
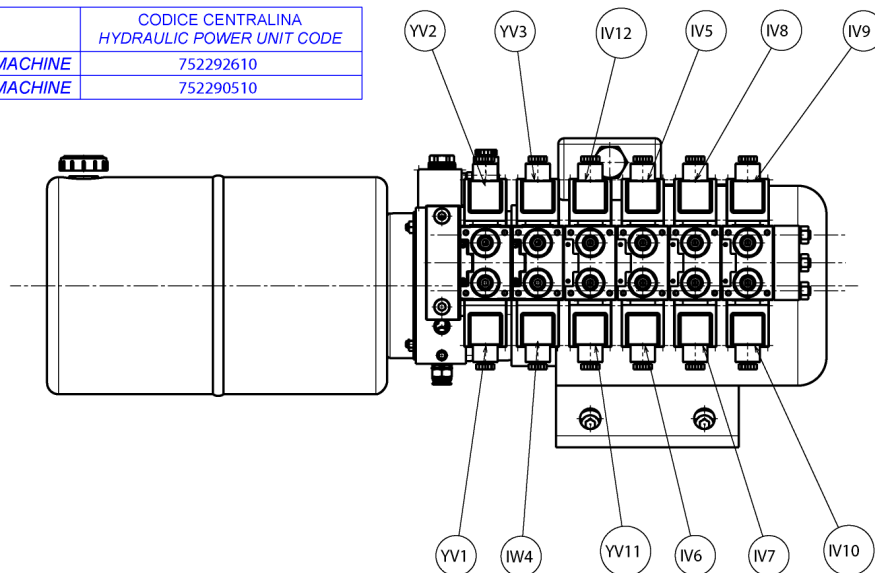
SCHEMA ELECTRIQUE 2/4
ESQUEMA ELECTRICO 2/4

(G9256D.15 - G9256T.15 - G10360D.15 - G10360T.15)

Pag. 80 di 168

G9256.11SL - G9256.11ST - G9256.15 - G9256T.15
G9256A.15 - G9256D.15 - G9256TD.15 - G9256.15SL
G10360.15 - G10360T.15 - G10360A.15
G10360D.15 - G10360TD.15

	CODICE CENTRALINA HYDRAULIC POWER UNIT CODE
MACCHINE NAV63/ NAV63 MACHINE	752292610
MACCHINE NAV43/ NAV43 MACHINE	752290510





RAVAGLIOLI S.p.A.

LISTA DEI COMPONENTI - LIST OF COMPONENTS - TEILELISTE
LISTE DES PIÈCES DÉTACHÉES - LISTA DE PIEZAS

Tavola N°E - Rev. 2

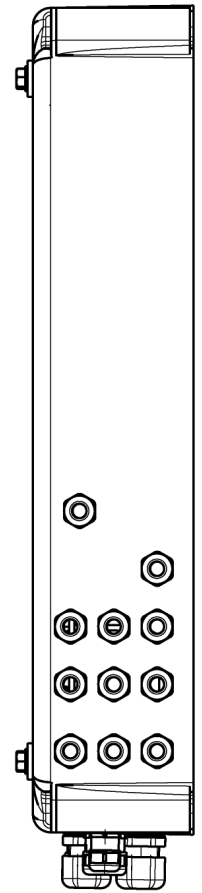
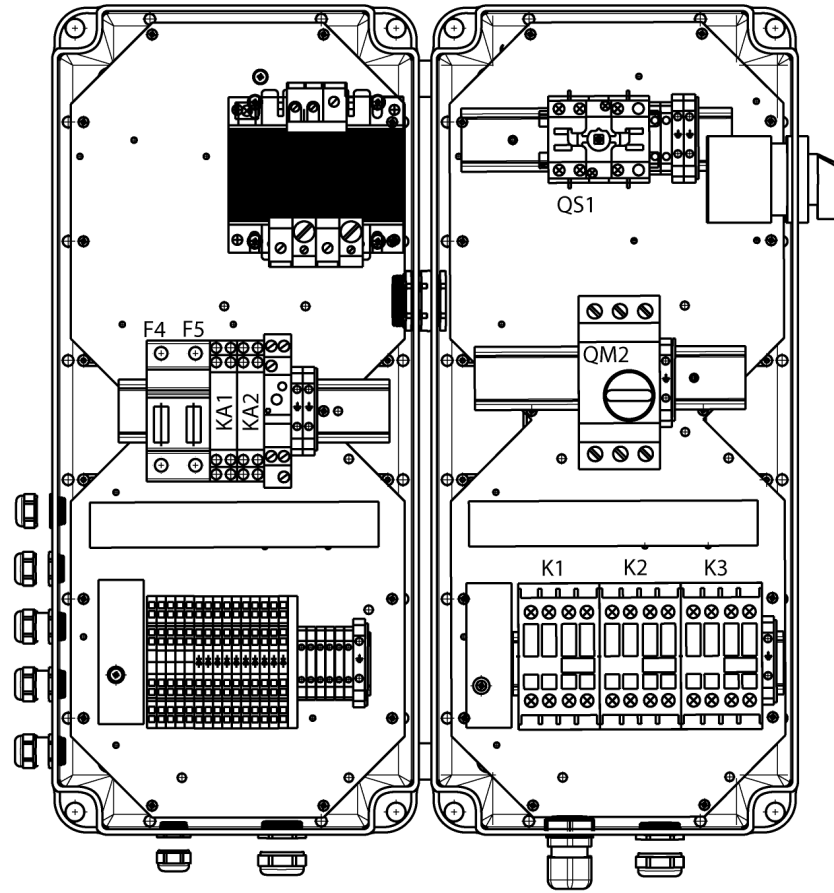
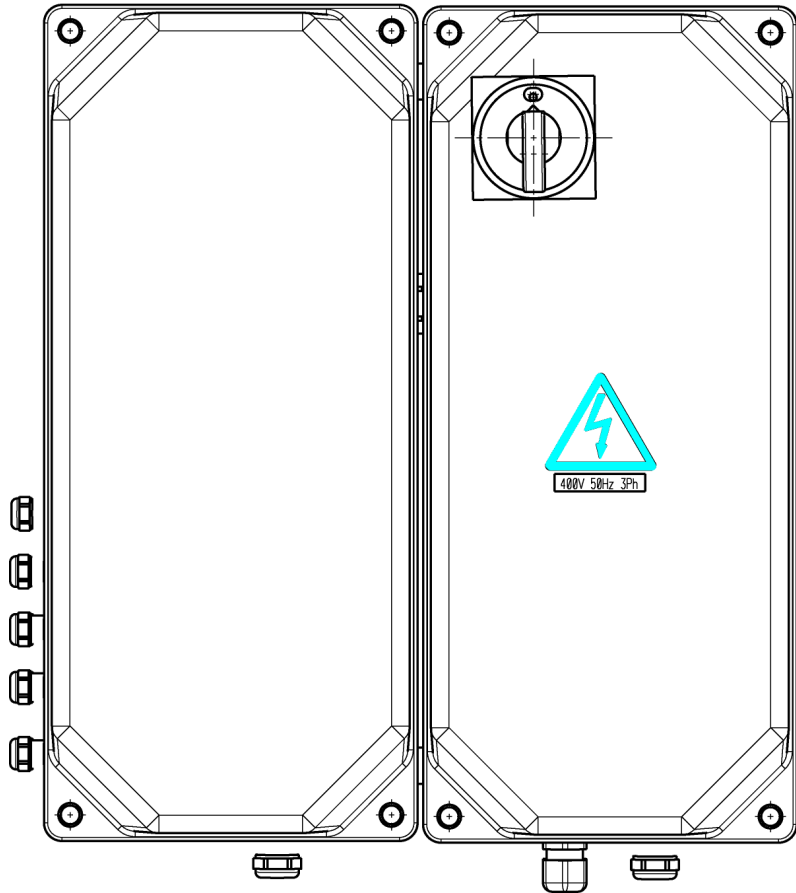
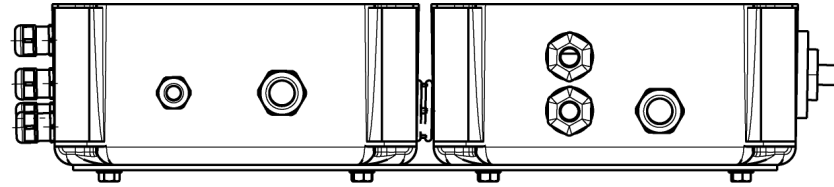
752205820

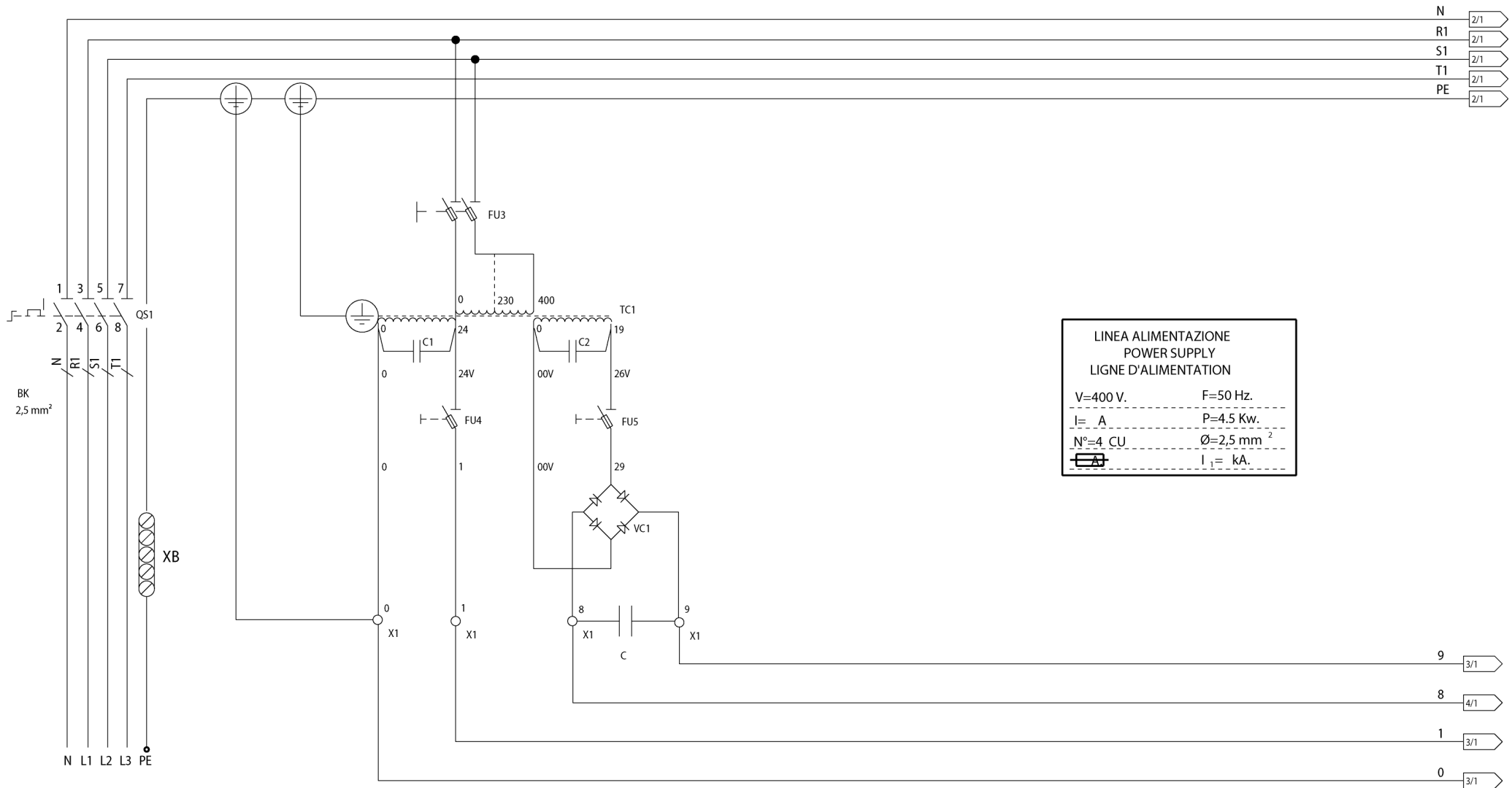
SCHEMA ELETTRICO 4/4
ELECTRICAL SCHEME 4/4
SCHALTPLAN 4/4
SCHEMA ELECTRIQUE 4/4
ESQUEMA ELECTRICO 4/4
(G9256D.15 - G9256TD.15 - G10360D.15 - G10360TD.15)

Pag. 82 di 168

G9256.11SL - G9256.11ST - G9256.15 - G9256T.15
G9256A.15 - G9256D.15 - G9256TD.15 - G9256.15SL
G10360.15 - G10360T.15 - G10360A.15
G10360D.15 - G10360TD.15

N°	Cod.	Descrizione	Description
	C	Condensatore elettrolitico	Electrolytic condenser
	D	Diodo 1N4007	1N4007 diode
	FU1	Fusibile protezione linea	Line guard fuse
	FU3	Fusibile protezione primario	First guard fuse
	FU4	Fusibile protezione secondario	Second guard fuse
	FU5	Fusibile protezione secondario	Second guard fuse
	KA2	Relè blocco comandi	Controls block relay
	KA3	Relè comando seconda velocità	Relay commande second speed
	KA5	Relè inibitore elettrovalvola in seconda velocità	Second speed solenoid valve inhibitor relay
	KM1	Contattore rotazione oraria mandrino	Chuck clockwise rot. Contactor
	KM2	Contattore rotazione antioraria mandrino	Chuck anticlockwise rot. Contactor
	KM3	Contattore comando prima velocità	First speed control contactor
	KM4/KM5	Contattore comando seconda velocità	Second speed control contactor
	KT1	Timer comando motore centralina	Hydraulic power unit control timer
	MF1	Freno motore mandrino	Chuck motor brake
	S5	Commutatore comando rotazione mandrino	Mandrel rotation control commutator
	S2	Manipolatore comando carro utensile avanti/indietro e salita/discesa	Handle for tool carriage forward/backward control
	S1	Manipolatore comando salita/discesa mandrino e movimento sx/movimento dx mandrino	Handle for mandrel up/down control handle and mandrel lh/rh movement
	M1	Motore mandrino	Chuck motor
	M2	Motore centralina	Hydraulic power unit motor
	QM2	Interruttore magnetotermico	Magnetic-thermique switch
	QS1	Interruttore generale	Main switch
	QS2	Commutatore di poli	Pole commutator
	S4	Pulsante apre/chiude mandrino	Mandrel open/close push-button
	S3	Pulsante comando rotazione utensili dx/sx	Rh/lh tools rotation control push-button
	S6	Pulsante seconda velocità centralina	Hydraulic power unit second speed push-button
	TC1	Trasformatore comandi	Control transformer
	VC1	Ponte raddrizzatore	Bridge
	YV1	Elettrovalvola movimento dx utensile	Tool rh movement solenoid valve
	YV2	Elettrovalvola movimento sx utensile	Tool lh movement solenoid valve
	YV3	Elettrovalvola movimento dx mandrino	Chuck rh movement solenoid valve
	YV4	Elettrovalvola movimento sx mandrino	Chuck lh movement solenoid valve
	YV5	Elettrovalvola chiude mandrino	Chuck closing solenoid valve
	YV6	Elettrovalvola apre mandrino	Chuck opening solenoid valve
	YV7	Elettrovalvola discesa mandrino	Chuck descent solenoid valve
	YV8	Elettrovalvola salita mandrino	Chuck rising solenoid valve
	YV9	Elettrovalvola entra utensile	Tool "in" solenoid valve
	YV10	Elettrovalvola esce utensile	Tool "out" solenoid valve
	YV11	Elettrovalvola rotazione Synodx	Rotation solenoid valve Synodx
	YV12	Elettrovalvola rotazione Synosx	Synosx rotation solenoid valve
	YV13	Elettrovalvola circolo olio	Oil circulation solenoid valve
	■	Morsetto	Morsetto





LINEA ALIMENTAZIONE
POWER SUPPLY
LIGNE D'ALIMENTATION

V=400 V. F=50 Hz.
I= A P=4.5 Kw.
N°=4 CU Ø=2,5 mm²
I₁= kA.

ALIMENTAZIONE AUSILIARIES
AUSILIARI 24VAC SUPPLY 24VAC

ALIMENTAZIONE AUSILIARIES
AUSILIARI 27VDC SUPPLY 27VDC



LISTA DEI COMPONENTI - LIST OF COMPONENTS - TEILELISTE
LISTE DES PIÈCES DÉTACHÉES - LISTA DE PIEZAS

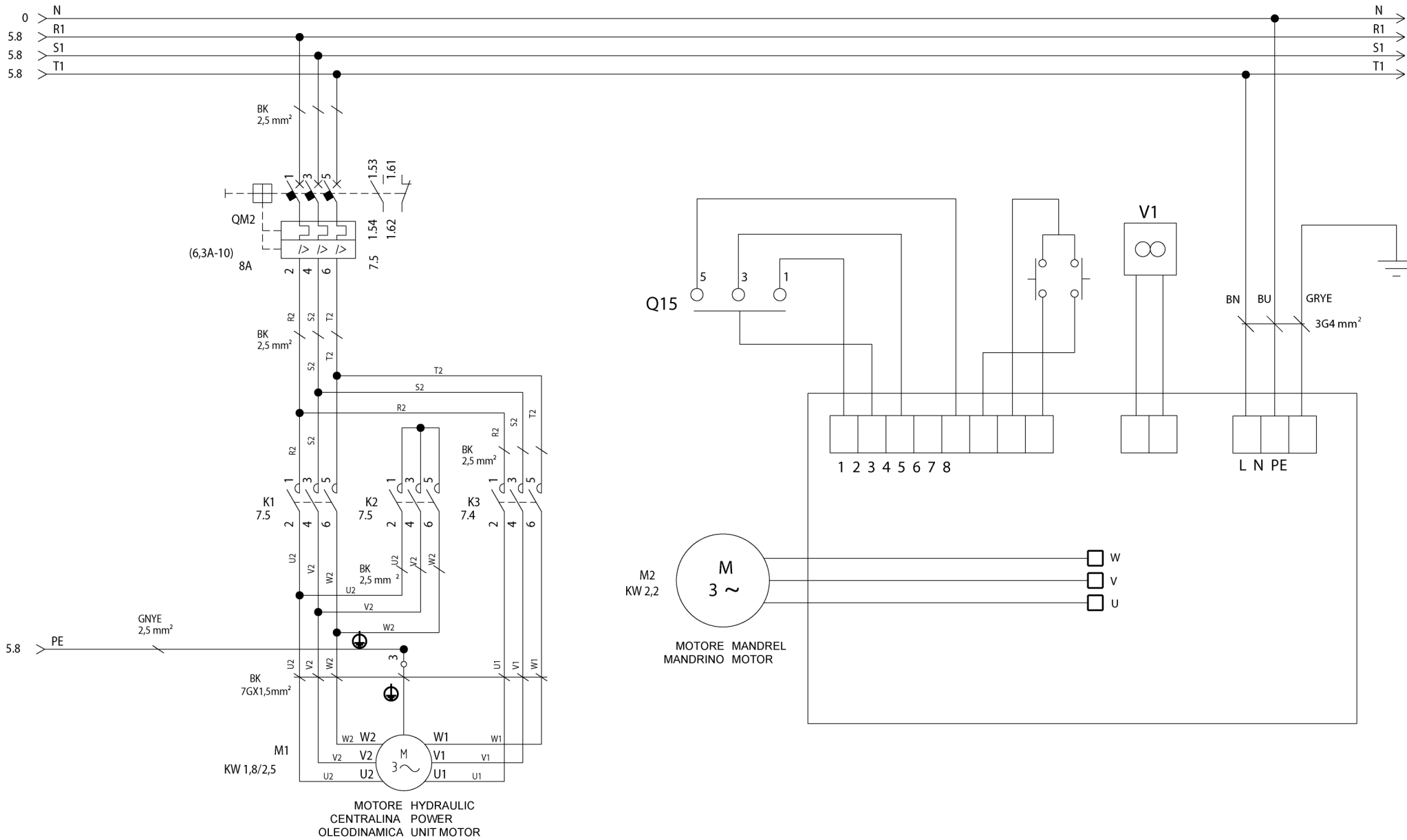
Tavola N°F - Rev. 1

752205701

SCHEMA ELETTRICO 2/10
ELECTRICAL SCHEME 2/10
SCHALTPLAN 2/10
SCHEMA ELECTRIQUE 2/10
ESQUEMA ELECTRICO 2/10
(G9256.11SL - G9256.15SL) (VARGNAV43AD)

Pag. 84 di 168

G9256.11SL - G9256.11ST - G9256.15 - G9256T.15
G9256A.15 - G9256D.15 - G9256TD.15 - G9256.15SL
G10360.15 - G10360T.15 - G10360A.15
G10360D.15 - G10360TD.15



LISTA DEI COMPONENTI - LIST OF COMPONENTS - TEILELISTE
LISTE DES PIÈCES DÉTACHÉES - LISTA DE PIEZAS

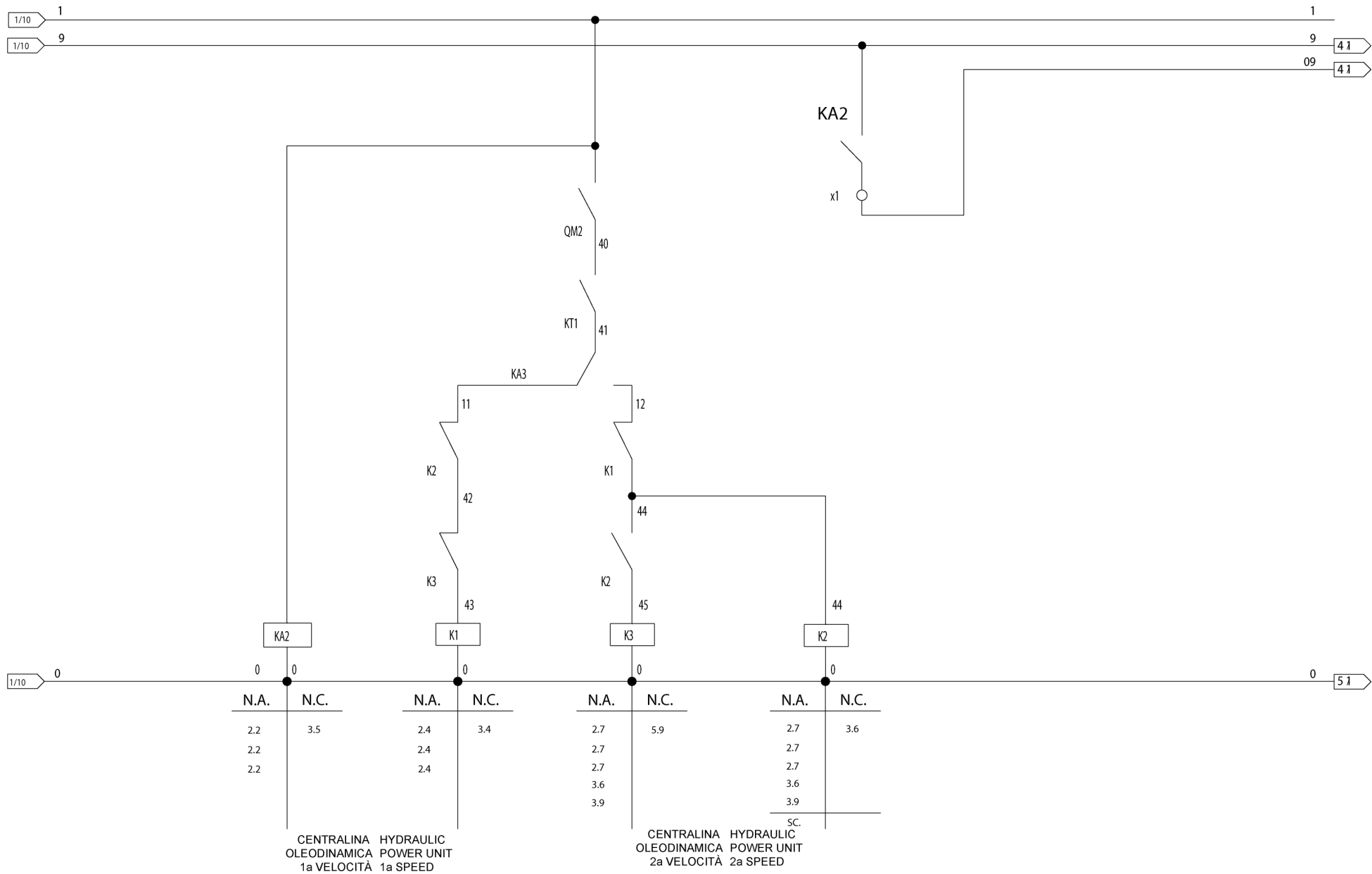
Tavola N°F - Rev. 1

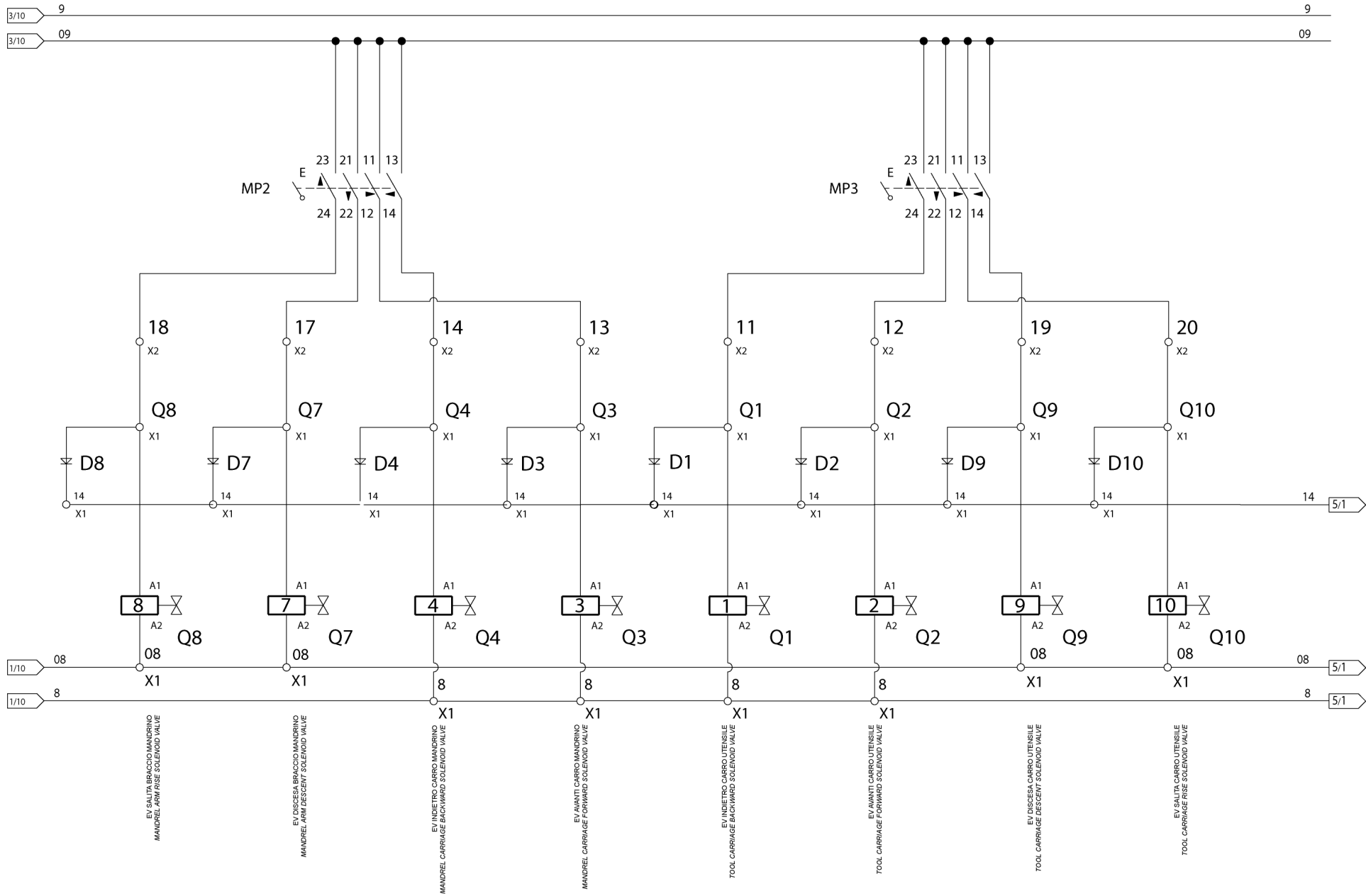
752205701

SCHEMA ELETTRICO 3/10
 ELECTRICAL SCHEME 3/10
 SCHALTPLAN 3/10
 SCHEMA ELECTRIQUE 3/10
 ESQUEMA ELECTRICO 3/10
 (G9256.11SL - G9256.15SL) (VARGNAV43AD)

Pag. 85 di 168

G9256.11SL - G9256.11ST - G9256.15 - G9256T.15
 G9256A.15 - G9256D.15 - G9256TD.15 - G9256.15SL
 G10360.15 - G10360T.15 - G10360A.15
 G10360D.15 - G10360TD.15





EV SALTITA BRACCIO MANDRINO
MANDREL ARM RISE SOLENOID VALVE

EV DISCESA BRACCIO MANDRINO
MANDREL ARM DESCENT SOLENOID VALVE

EV INDIETRO CARRO MANDRINO
MANDREL CARRIAGE BACKWARD SOLENOID VALVE

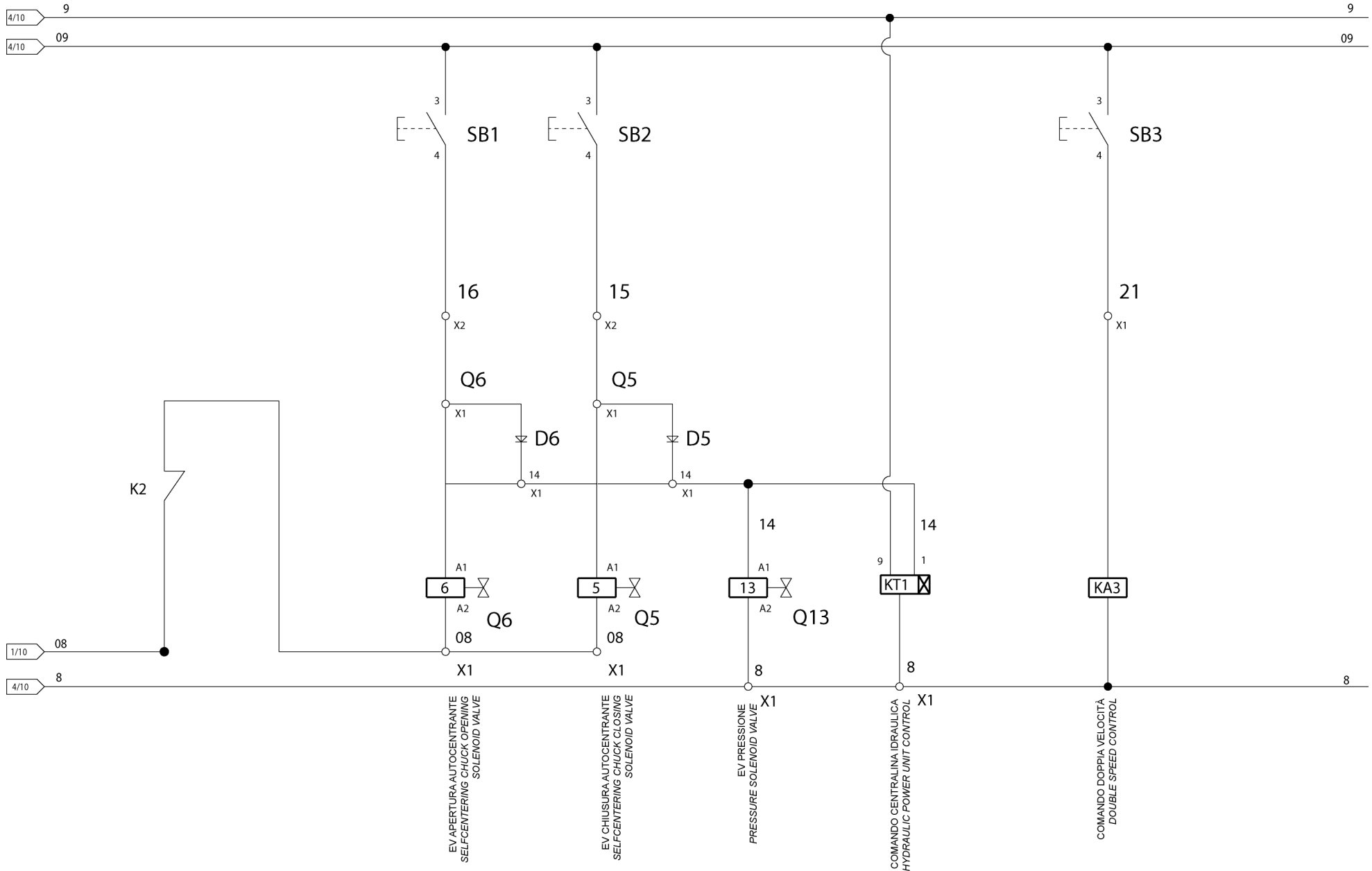
EV AVANTI CARRO MANDRINO
MANDREL CARRIAGE FORWARD SOLENOID VALVE

EV INDIETRO CARRO UTENSILE
TOOL CARRIAGE BACKWARD SOLENOID VALVE

EV AVANTI CARRO UTENSILE
TOOL CARRIAGE FORWARD SOLENOID VALVE

EV DISCESA CARRO UTENSILE
TOOL CARRIAGE DESCENT SOLENOID VALVE

EV SALTITA CARRO UTENSILE
TOOL CARRIAGE RISE SOLENOID VALVE



EV APERTURA AUTOCENTRANTE
SELF-CENTERING CHUCK OPENING
SOLENOID VALVE

EV CHIUSURA AUTOCENTRANTE
SELF-CENTERING CHUCK CLOSING
SOLENOID VALVE

EV PRESSIONE
PRESSURE SOLENOID VALVE

COMANDO CENTRALINA IDRAULICA
HYDRAULIC POWER UNIT CONTROL

COMANDO DOPPIA VELOCITA'
DOUBLE SPEED CONTROL



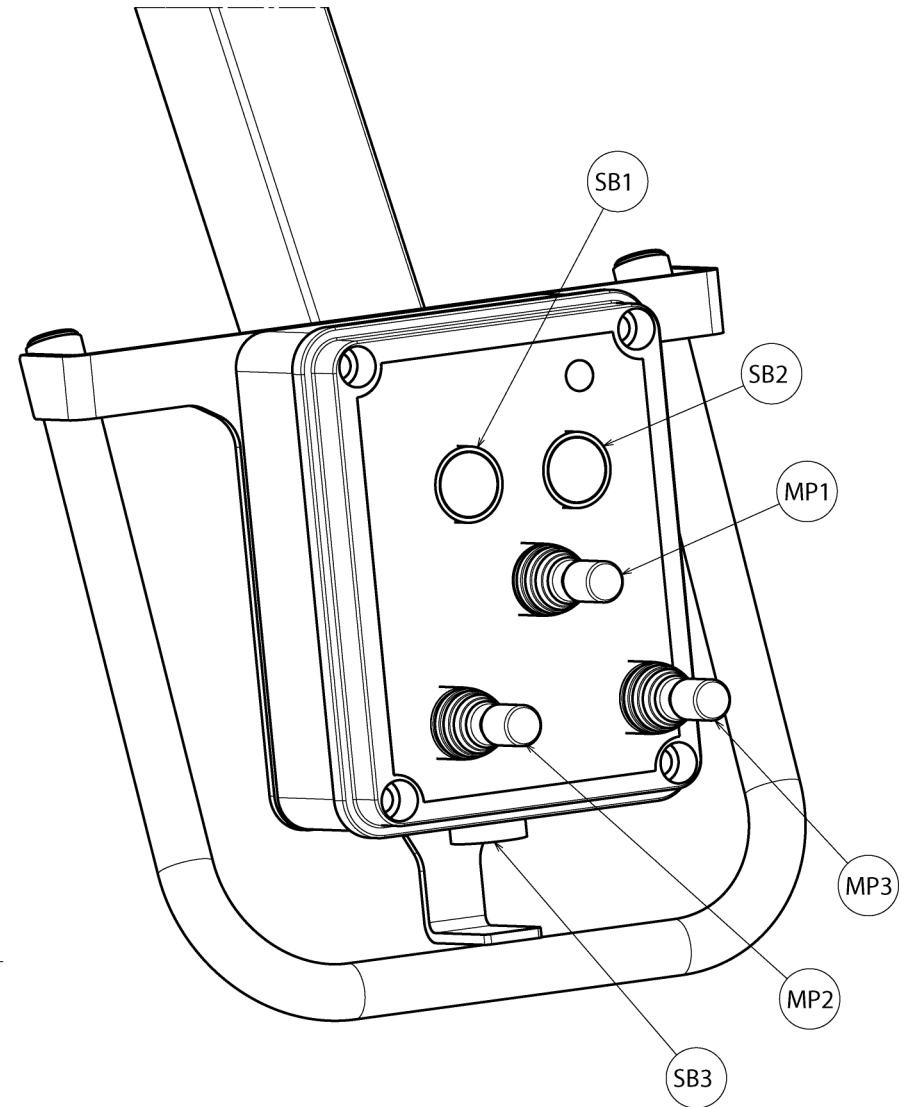
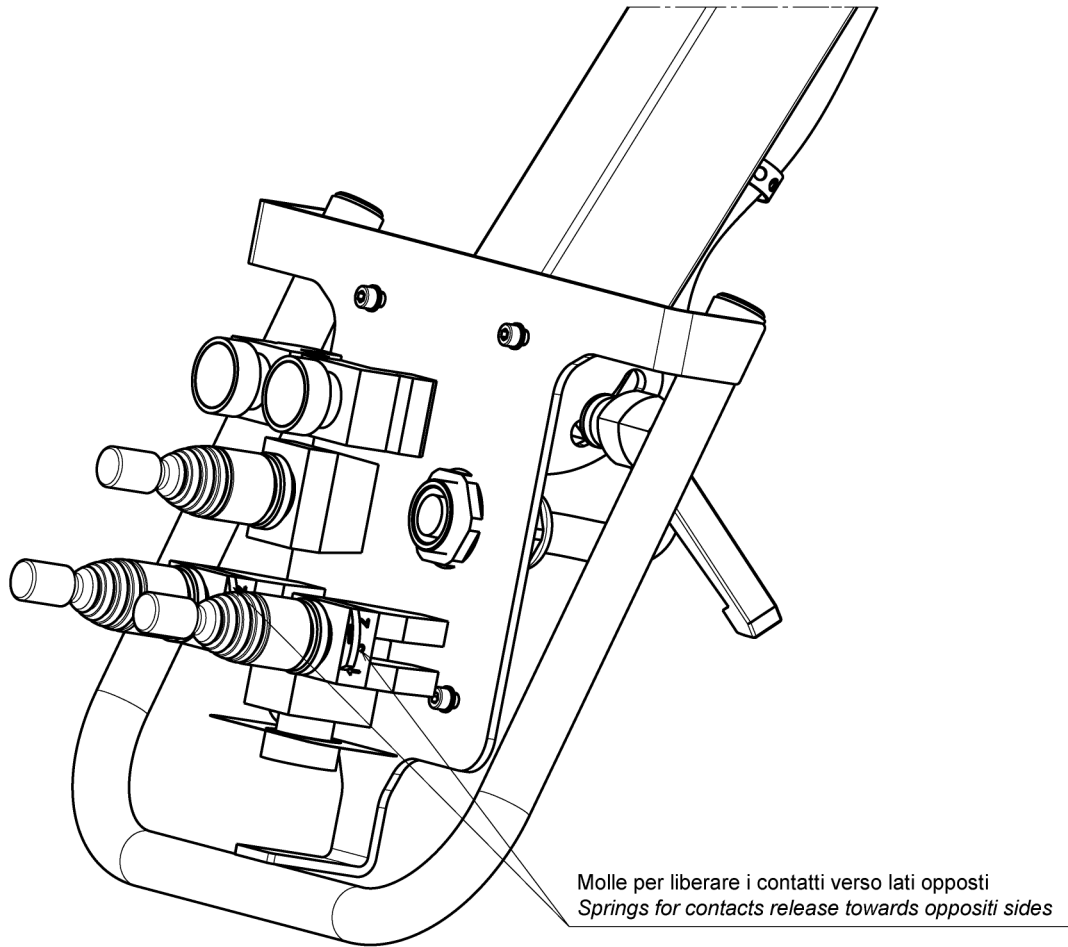
LISTA DEI COMPONENTI - LIST OF COMPONENTS - TEILELISTE
LISTE DES PIECES DETACHEES - LISTA DE PIEZAS

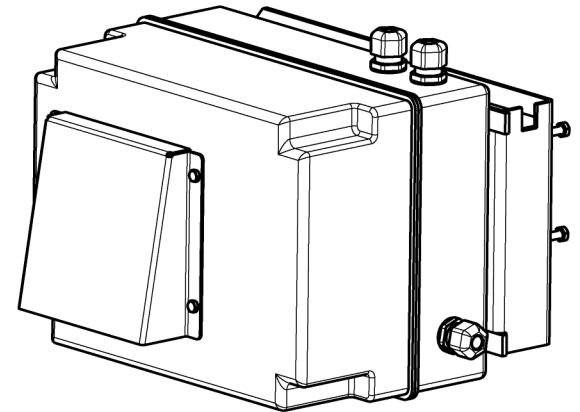
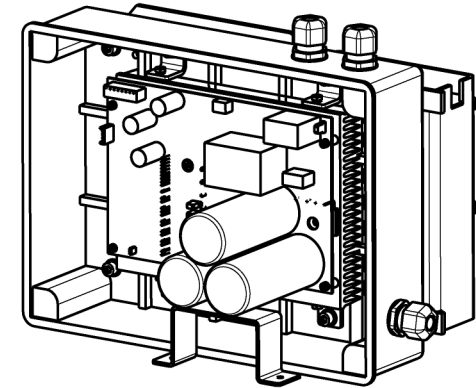
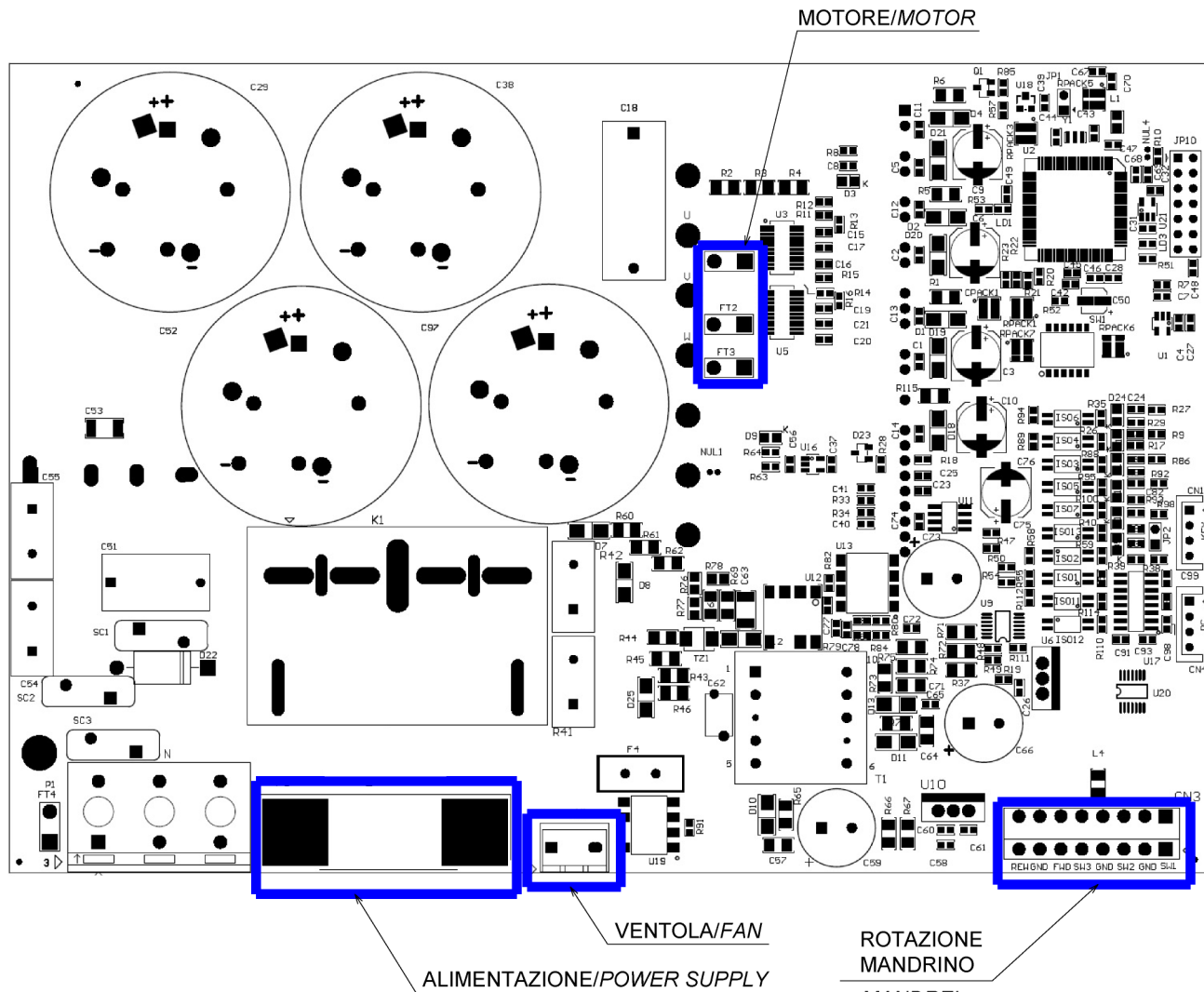
Tavola N°F - Rev. 1

752205701

SCHEMA ELETTRICO 6/10
ELECTRICAL SCHEME 6/10
SCHALTPLAN 6/10
SCHEMA ELECTRIQUE 6/10
ESQUEMA ELECTRICO 6/10
(G9256.11SL - G9256.15SL) (VARGNAV43AD)

Pag. 88 di 168
G9256.11SL - G9256.11ST - G9256.15 - G9256T.15
G9256A.15 - G9256D.15 - G9256TD.15 - G9256.15SL
G10360.15 - G10360T.15 - G10360A.15
G10360D.15 - G10360TD.15





cod.752293060

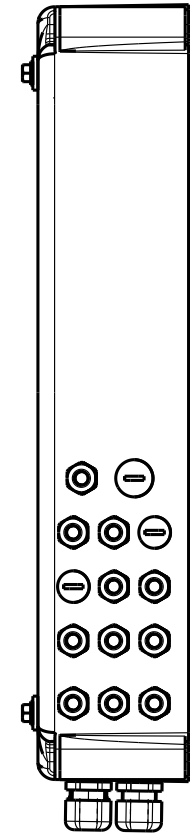
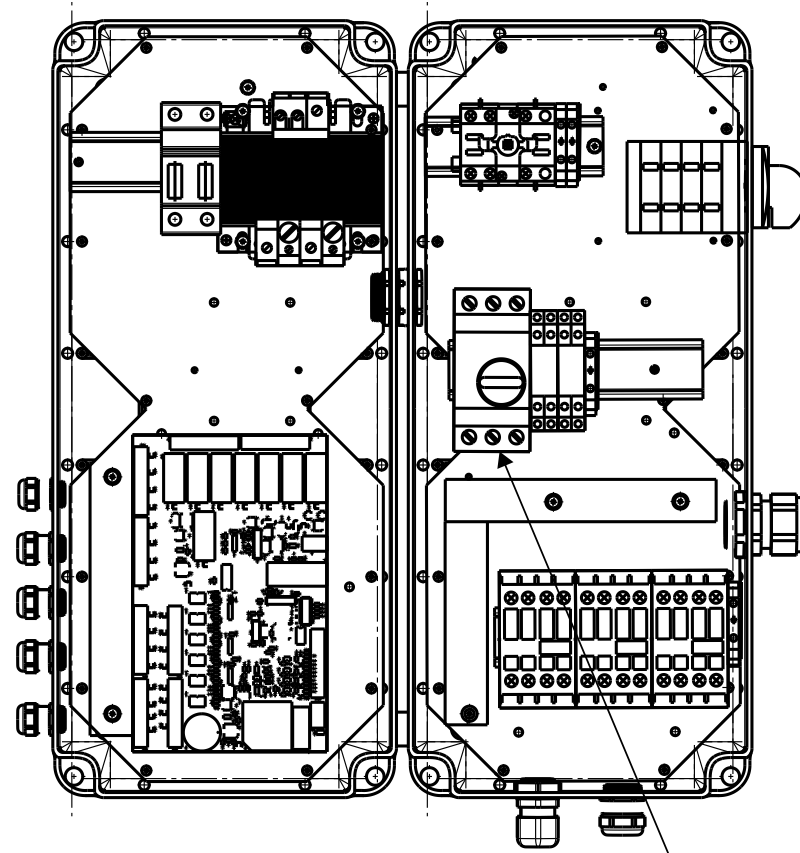
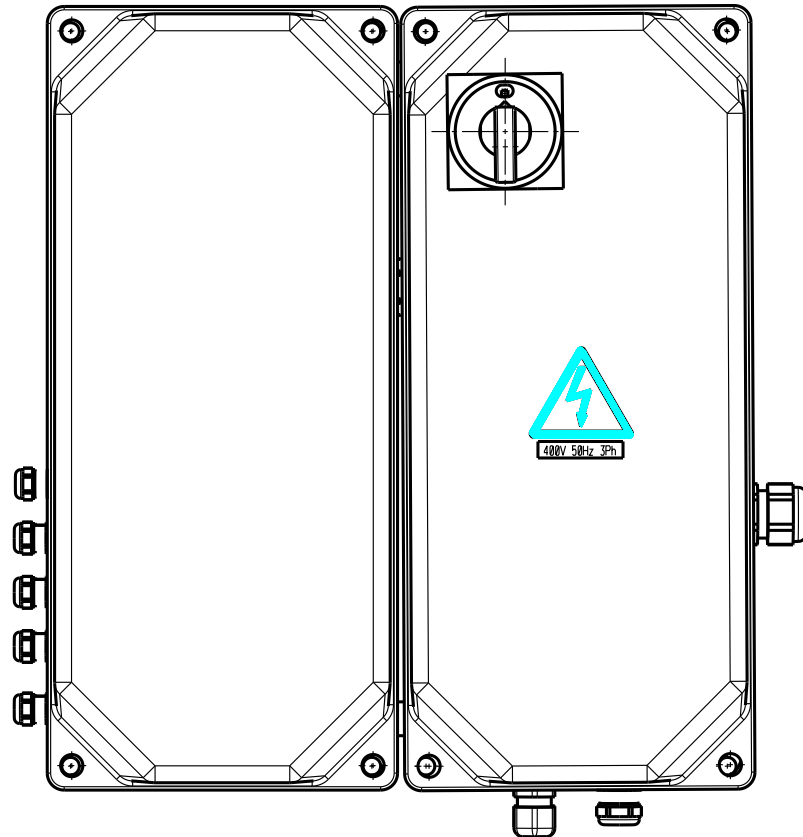
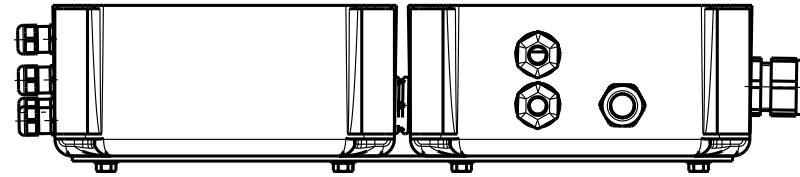
Programmazione MODO 2 - 752205760
 MODE 2 programming - 752205760

LISTA COMPONENTI

RIFERIMENTO	DESCRIZIONE	DATI TECNICI	SIGLA CATALOGO	QUANTITA	RIFERIMENTO DOCUMENTO
F1	PORTAFUSIBILE	3 POLI SEZIONABILE 10,3x38 32A 690V	515025	1	6.6
	FUSIBILE	10,3x38 16A 500V aM RITARDATO	507045	3	
F2	INTERRUTTORE AUTOM. TRIPOLARE	6,3-10A AC3 400V 2,2KW	518277	1	6.2
	CONTATTI AUSILIARI	1NO+1NC ATTACCO FRONTALE	518279	1	6.2
F3	PORTAFUSIBILE	2 POLI SEZIONABILE 10,3x38 32A 690V	515027	1	5.3
	FUSIBILE	10,3X38 2A 500V RAPIDO	507019	2	
F4	FUSIBILE	5x20F 250V 2A RAPIDO	507043	1	5.3
F5	FUSIBILE	5x20F 250V 8A RAPIDO	507090	1	5.3
F6	FUSIBILE	5X20 T 8A 250V	507118	1	5.7
G1	BATTERIA	6V 3,3AH/20HR Lead	10066	1	14.6
K1	CONTATTORE TRIPOLARE	9A AC3 400V 4,2KW 1NC 24Vac 50/60Hz	522137	1	7.6
K2	CONTATTORE TRIPOLARE	9A AC3 400V 4,2KW 1NC 24Vac 50/60Hz	522137	1	7.6
K3	CONTATTORE TRIPOLARE	9A AC3 400V 4,2KW 1NC 24Vac 50/60Hz	522137	1	7.5
K4	CONTATTORE TRIPOLARE	9A AC3 400V 4,2KW 1NC 24Vac 50/60Hz	522137	1	7.5
	CONTATTI AUSILIARI	1NO+1NC ATTACCO FRONTALE	522147	1	7.4
K5	CONTATTORE	9A AC3 400V 4,2KW 1NC 24Vac 50/60Hz	522137	1	7.4
P2	INDICATORE LUMINOSO (LED)	ROSSO	18065	1	15.4
P3	INDICATORE LUMINOSO (LED)	VERDE	18066	1	15.5
Q1...Q13	ELETTROVALVOLE	-	-	13	8-9
Q14	SEZIONATORE TRIPOLARE	lth 32A Ui 690V-50Hz Uimp 4KW	518223+518226	1	5.2
Q15	COMMUTATORE DI POLI DAHLANDER	25A 500V	518189	1	6.5-6.6
MP3	MANIPOLATORE	MANIPOLATORE C 4 POS. TEMPORANEE	517285	1	14.2
MP2	MANIPOLATORE	MANIPOLATORE C 4 POS. TEMPORANEE	517285	1	14.2
MP1	MANIPOLATORE	MANIPOLATORE C 2 POS. TEMPORANEE	517286	-	-
SB1	PULSANTE	PULSANTE IP 55	4511000	1	14.4
SB2	PULSANTE	PULSANTE IP 55	4511000	1	14.7-14.8
SB3	PULSANTE	PULSANTE IP 55	4511000	1	14.5
T1	TRASFORMATORE	200 VA 50/60 Hz PRI: 0/230/400V SEC: 0/19V 8,95A 0/24V 1,25A	528056	1	5.3
M1	MOTORE CENTRALINA	1,85/2,5KW 400V 50HZ 4,9/7,7A cosØ=0,73/0,70 1400/2800 rpm	900003880	1	6.3
M2	MOTORE MANDRINO	2,2KW 160/277V 50Hz 7.8/13.5A cosØ=0,78 1400rpm.	900004320	1	

COMPONENTS LIST

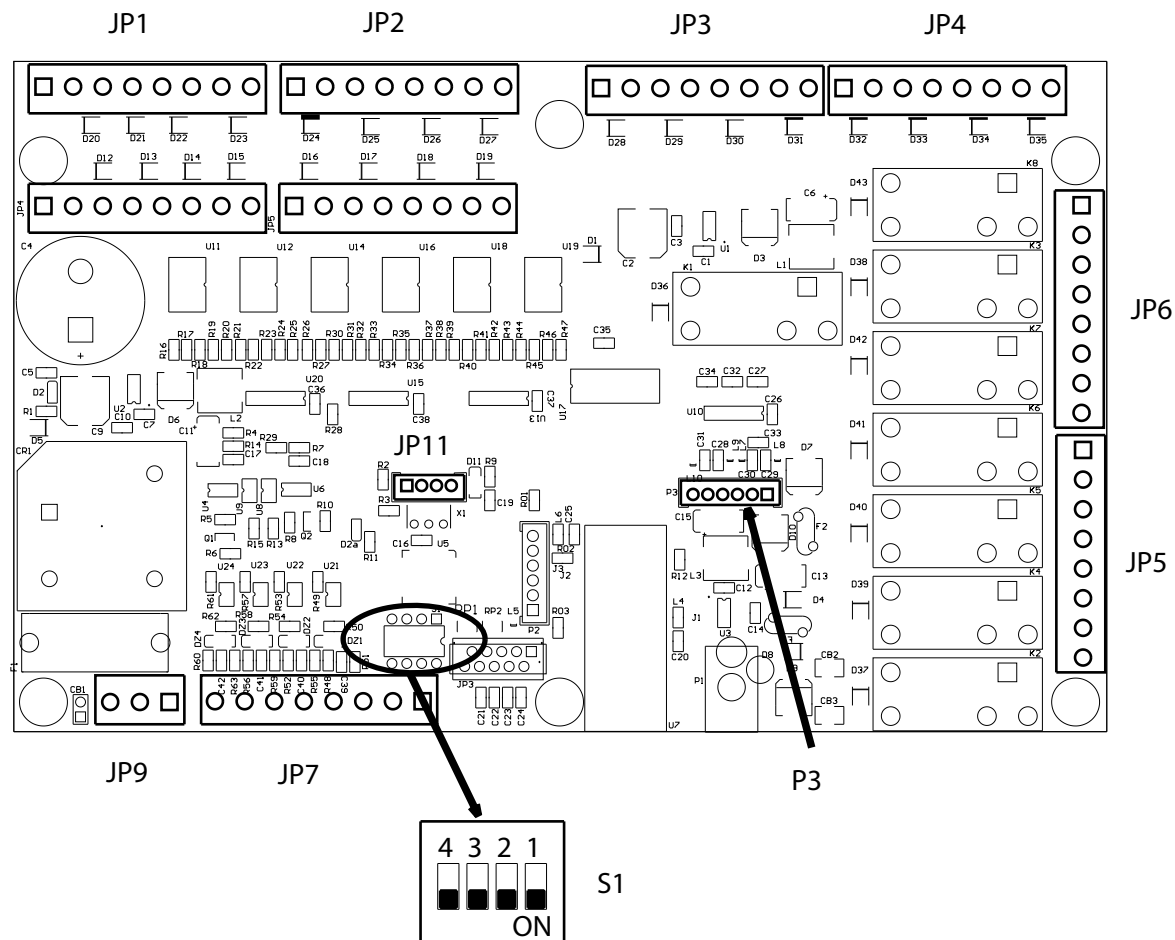
REFERENCE	DESCRIPTION	TECHNICAL SPECIFICATIONS	ABBREVIATION ON CATALOGUE	QUANTITY	DOCUMENT REFERENCE
F1	FUSE HOLDER	10,3x38 32A 690V SECTIONABLE 3 POLES	515025	1	6.6
	FUSE	10,3x38 16A 500V aM DELAYED-ACTION	507045	3	
F2	TRIPOLAR AUTOMATIC SWITCH	6,3-10A AC3 400V 2,2KW	518277	1	6.2
	AUXILIARY CONTACTS	1NO+1NC FRONT COUPLING	518279	1	6.2
F3	FUSE HOLDER	10,3x38 32A 690V 2 POLES SECTIONABLE	515027	1	5.3
	FUSE	10,3x38 2A 500V RAPID	507019	2	
F4	FUSE	5x20F 250V 2A RAPID	507043	1	5.3
F5	FUSE	5x20F 250V 8A RAPID	507090	1	5.3
F6	FUSE	5X20 T 8A 250V	507118	1	5.7
G1	BATTERY	6V 3,3AH/20HR Lead	10066	1	14.6
K1	TRIPOLAR CONTACTOR	9A AC3 400V 4,2KW 1NC 24Vac 50/60Hz	522137	1	7.6
K2	TRIPOLAR CONTACTOR	9A AC3 400V 4,2KW 1NC 24Vac 50/60Hz	522137	1	7.6
K3	TRIPOLAR CONTACTOR	9A AC3 400V 4,2KW 1NC 24Vac 50/60Hz	522137	1	7.5
K4	TRIPOLAR CONTACTOR	9A AC3 400V 4,2KW 1NC 24Vac 50/60Hz	522137	1	7.5
	AUXILIARY CONTACTS		522147	1	7.4
K5	CONTACTOR	9A AC3 400V 4,2KW 1NC 24Vac 50/60Hz	522137	1	7.4
P2	BACKLIGHTED INDICATOR (LED)	RED	18065	1	15.4
P3	BACKLIGHTED INDICATOR (LED)	GREEN	18066	1	15.5
Q1...Q13	SOLENOID VALVES	-	-	13	8-9
Q14	TRIPOLAR KNIFE SWITCH	Ith 32A Ui 690V-50Hz Uimp 4KW	518223+518226	1	5.2
Q15	DAHLANDER POLES COMMUTATOR	25A 500V	518189	1	6.5-6.6
MP3	HANDLE CONTROL	HANDLE CONTROL C4 POS. TEMPORARY	517285	1	14.2
MP2	HANDLE CONTROL	HANDLE CONTROL C4 POS. TEMPORARY	517285	1	14.2
MP1	HANDLE CONTROL	HANDLE CONTROL C2 POS. TEMPORARY	517286	-	-
SB1	PUSHBUTTON	IP55 PUSHBUTTON	4511000	1	14.4
SB2	PUSHBUTTON	IP55 PUSHBUTTON	4511000	1	14.7-14.8
SB3	PUSHBUTTON	IP55 PUSHBUTTON	4511000	1	14.5
T1	TRANSFORMER	200 VA 50/60 Hz PRI: 0/230/400V SEC: 0/19V 8,95A 0/24V 1,25A	528056	1	5.3
M1	HYDRAULIC POWER UNIT MOTOR	1,85/2,5KW 400V 50HZ 4,9/7,7A cos ϕ =0,73/0,70 1400/2800 rpm	900003880	1	6.3
M2	MANDREL MOTOR	2,2KW 160/277V 50Hz 7.8/13.5A cos ϕ =0,78 1400rpm.	900004320	1	



Tarare il salvamotore a 8A
Set the overload cut-out at 8A

TOPOGRAFICO SCHEDA RICEVENTE 18962

RECEIVING CARD 18962 TOPOGRAPHIC VIEW



IN/OUT SCHEDA RICEVENTE 18962

PIN JP1	NUMERO	FUNZIONE
1	JP1-1	Q1 INDIETRO CARRO UTENSILE
2	JP1-2	0V per Q1
3	JP1-3	Q2 AVANTI CARRO UTENSILE
4	JP1-4	0V per Q2
5	JP1-5	Q3 AVANTI CARRO MANDRINO
6	JP1-6	0V per Q3
7	JP1-7	Q4 INDIETRO CARRO MANDRINO
8	JP1-8	0V per Q4

PIN JP2	NUMERO	FUNZIONE
1	JP2-1	Q5 CHIUSURA MANDRINO
2	JP2-2	0V per Q5
3	JP2-3	Q6 APERTURA MANDRINO
4	JP2-4	0V per Q6
5	JP2-5	Q7 DISCESA BRACCIO MANDRINO
6	JP2-6	0V per Q7
7	JP2-7	Q8 SALITA BRACCIO MANDRINO
8	JP2-8	0V per Q8

PIN JP3	NUMERO	FUNZIONE
1	JP3-1	Q9 ROTAZ.ANTIORARIA UTENSILE
2	JP3-2	0V per Q9
3	JP3-3	Q10 ROTAZ.ORARIA UTENSILE
4	JP3-4	0V per Q10
5	JP3-5	Q11 DISCESA BRACCIO UTENSILE
6	JP3-6	0V per Q11
7	JP3-7	Q12 SALITA BRACCIO UTENSILE
8	JP3-8	0V pe Q12

PIN JP4	NUMERO	FUNZIONE
1	JP4-1	Q13 RICIRCOLO OLIO
2	JP4-2	0V per Q13
3	JP4-3	N.U.
4	JP4-4	N.U.
5	JP4-5	N.U.
6	JP4-6	N.U.
7	JP4-7	N.U.
8	JP4-8	N.U.

PIN JP5	NUMERO	FUNZIONE
1	JP5-1	N.U.
2	JP5-2	N.U.
3	JP5-3	0 Vac
4	JP5-4	KM5 COMANDO ROTAZ. 2V CENTRALINA OLEOD
5	JP5-5	KM4 COMANDO MOTORE CENTRALINA A STELLA 2V
6	JP5-6	KM3 COMANDO ROTAZ. 1V CENTRALINA OLEOD
7	JP5-7	KA1 COMANDO ROTAZ. ORARIA MANDRINO
8	JP5-8	KA2 COMANDO ROTAZ. ANTIORARIA MANDRINO

PIN JP7	NUMERO	FUNZIONE
1	JP7-1	COLLEGATO A JP7-2
2	JP7-2	COLLEGATO A JP7-1
3	JP7-3	N.U.
4	JP7-4	N.U.
5	JP7-5	N.U.
6	JP7-6	N.U.
7	JP7-7	N.U.
8	JP7-8	N.U.

PIN JP9	NUMERO	FUNZIONE
1	JP9-1	0 Vac
2	JP9-2	N.U.
3	JP9-3	19 Vac



RAVAGLIOLI S.p.A.

**LISTA DEI COMPONENTI - LIST OF COMPONENTS - TEILELISTE
LISTE DES PIECES DETACHEES - LISTA DE PIEZAS**

Tavola N°G - Rev. 0

752205690

SCHEMA ELETTRICO 3/19
ELECTRICAL SCHEME 3/19
SCHALTPLAN 3/19
SCHEMA ELECTRIQUE 3/19
ESQUEMA ELECTRICO 3/19
(G9256.15SL) (VARIANTE INVERTER)

Pag. 95 di 168

G9256.11SL - G9256.11ST - G9256.15 - G9256T.15
G9256A.15 - G9256D.15 - G9256TD.15 - G9256.15SL
G10360.15 - G10360T.15 - G10360A.15
G10360D.15 - G10360TD.15

7522-M001-14_R

RECEIVING CARD 18962 IN/OUT

PIN JP1	NUMBER	FUNCTION
1	JP1 - 1	Q1 TOOL CARRIAGE BACKWARD
2	JP1 - 2	OV for Q1
3	JP1 - 3	Q2 TOOL CARRIAGE FORWARD
4	JP1 - 4	OV for Q2
5	JP1 - 5	Q3 MANDREL CARRIAGE FORWARD
6	JP1 - 6	OV for Q3
7	JP1 - 7	Q4 MANDREL CARRIAGE BACKWARD
8	JP1 - 8	OV for Q4

PIN JP2	NUMBER	FUNCTION
1	JP2 - 1	Q5 MANDREL CLOSING
2	JP2 - 2	OV for Q5
3	JP2 - 3	Q6 MANDREL OPENING
4	JP2 - 4	OV for Q6
5	JP2 - 5	Q7 MANDREL ARM DESCENT
6	JP2 - 6	OV for Q7
7	JP2 - 7	Q8 MANDREL ARM RISE
8	JP2 - 8	OV for Q8

PIN JP3	NUMBER	FUNCTION
1	JP3 - 1	Q9 TOOL COUNTERCLOCKWISE ROT.
2	JP3 - 2	OV for Q9
3	JP3 - 3	Q10 TOOL CLOCKWISE ROTATION
4	JP3 - 4	OV for Q10
5	JP3 - 5	Q11 TOOL ARM DESCENT
6	JP3 - 6	OV for Q11
7	JP3 - 7	Q12 TOOL ARM RISE
8	JP3 - 8	OV for Q12

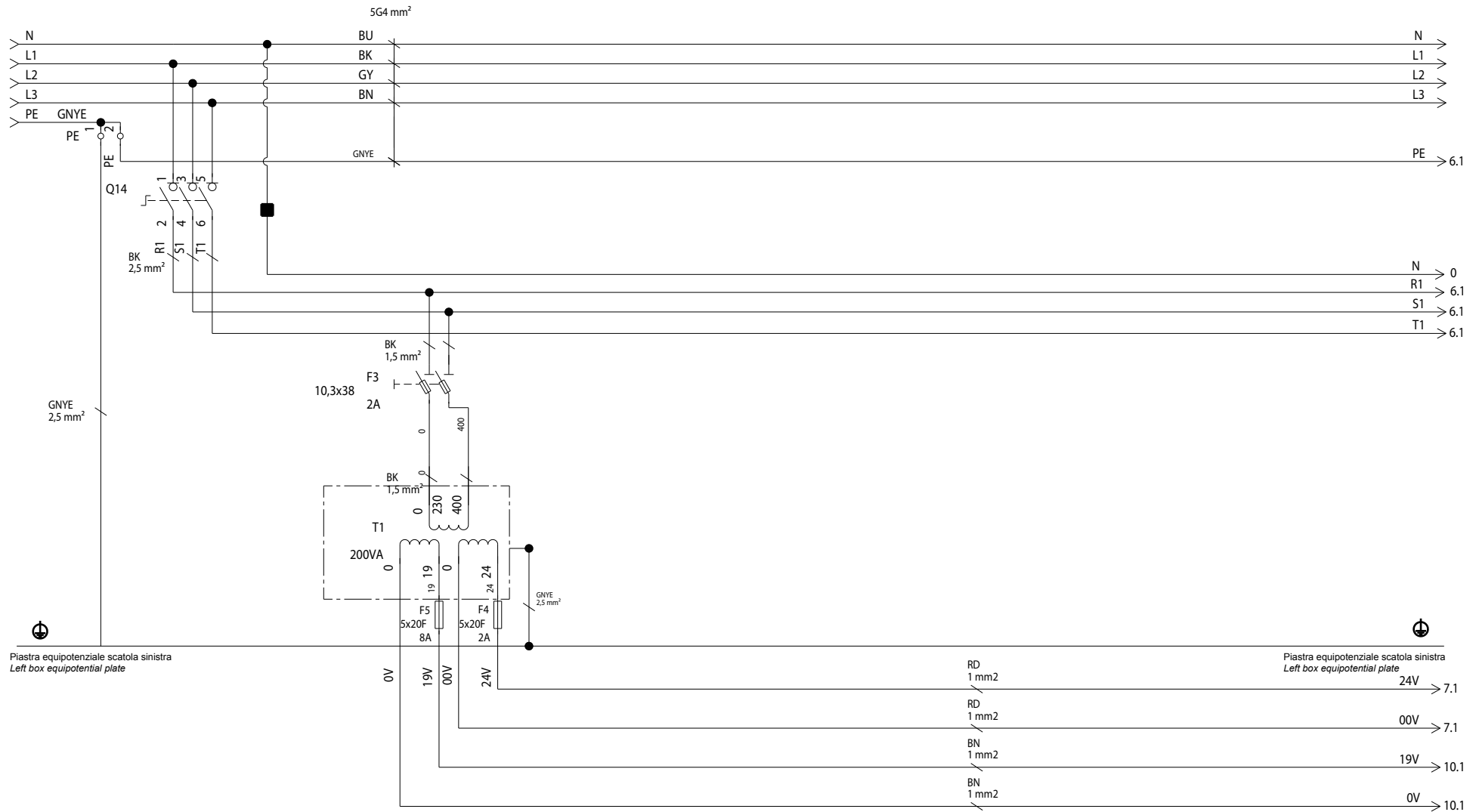
PIN JP4	NUMBER	FUNCTION
1	JP4 - 1	Q13 OIL RECIRCULATION
2	JP4 - 2	OV for Q13
3	JP4 - 3	N.U.
4	JP4 - 4	N.U.
5	JP4 - 5	N.U.
6	JP4 - 6	N.U.
7	JP4 - 7	N.U.
8	JP4 - 8	N.U.

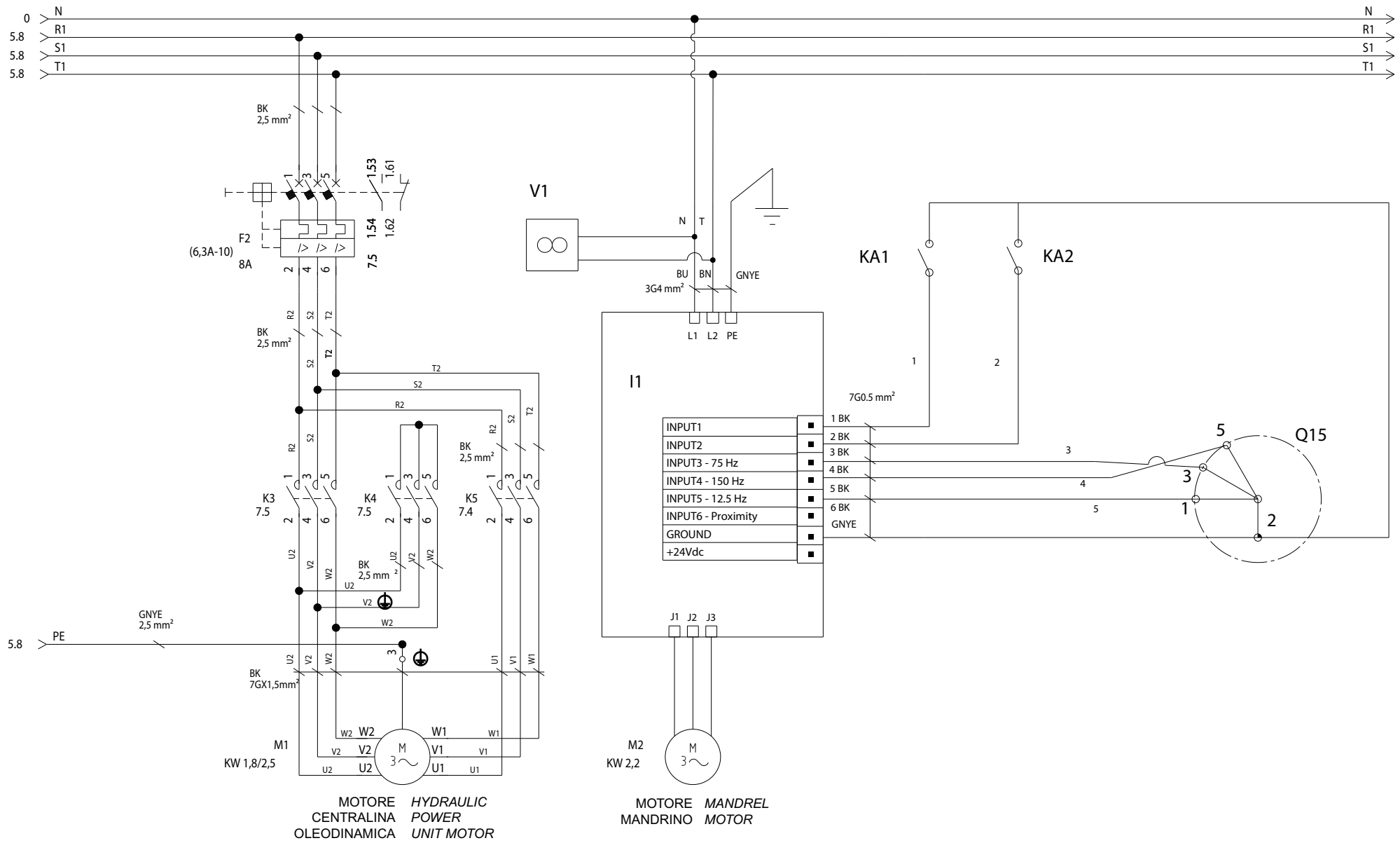
PIN JP5	NUMBER	FUNCTION
1	JP5 - 1	N.U.
2	JP5 - 2	N.U.
3	JP5 - 3	0 Vac
4	JP5 - 4	KM5 2V HYDR. POWER UNIT ROTATION CONTROL
5	JP5 - 5	KM4 2V STAR TYPE HYDR. POWER UNIT MOTOR ROT. CONTR.
6	JP5 - 6	KM3 1V HYDRAULIC POWER UNIT ROT. CONTROL
7	JP5 - 7	KM2 MANDREL CLOCKWISE ROTATION CONTROL
8	JP5 - 8	KM1 MANDREL COUNTERCLOCKWISE ROT. CONTROL

PIN JP7	NUMBER	FUNCTION
1	JP7 - 1	CONNECTED TO JP7-2
2	JP7 - 2	CONNECTED TO JP7-1
3	JP7 - 3	N.U.
4	JP7 - 4	N.U.
5	JP7 - 5	N.U.
6	JP7 - 6	N.U.
7	JP7 - 7	N.U.
8	JP7 - 8	N.U.

PIN JP9	NUMBER	FUNCTION
1	JP9 - 1	0 Vac
2	JP9 - 2	N.U.
3	JP9 - 3	19 Vac

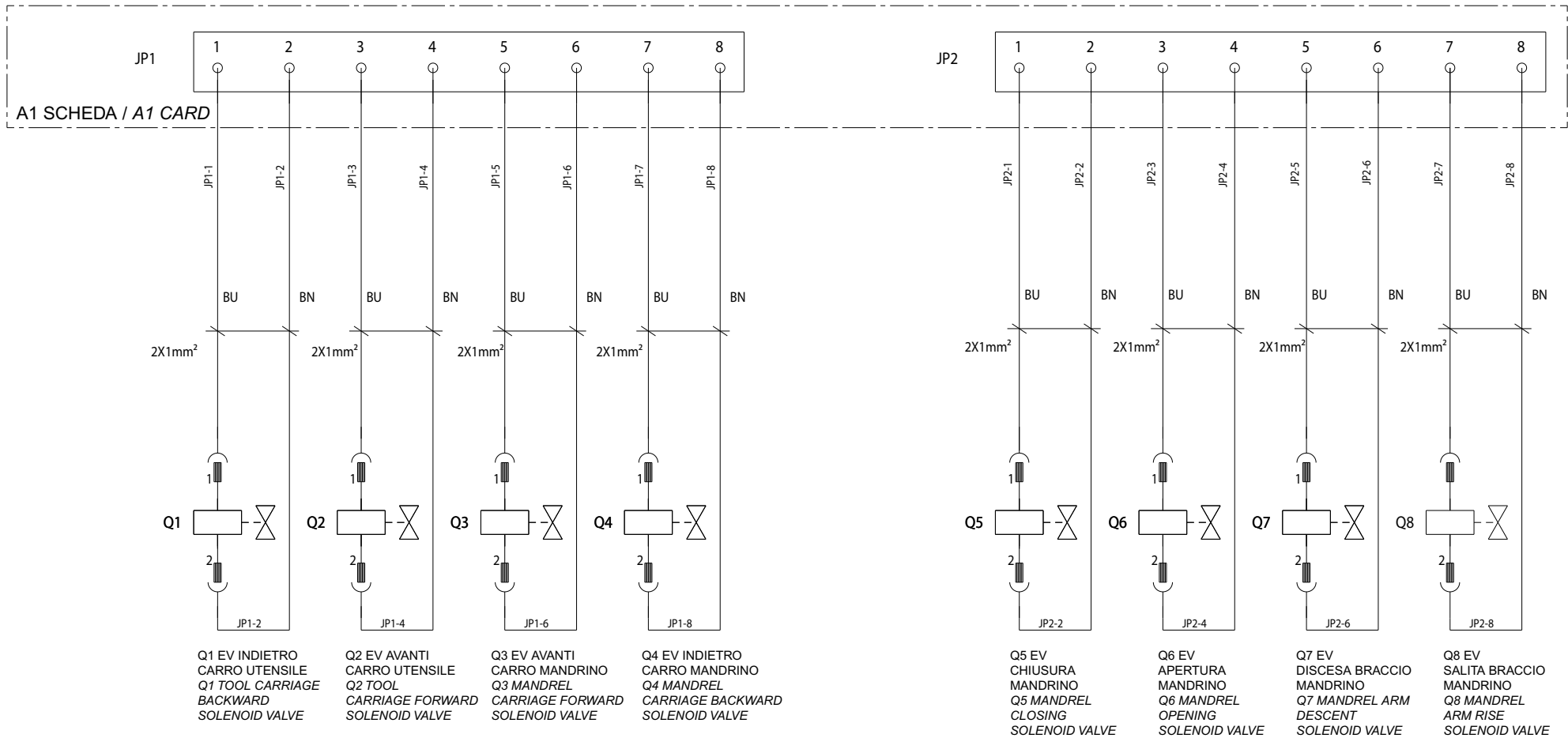
SCHEMA CIRCUITI QUADRO ELETTRICO (RICEVITORE) ELECTRICAL PANEL (RECEIVER) CIRCUITS DIAGRAM





MOTORE HYDRAULIC
CENTRALINA POWER
OLEODINAMICA UNIT MOTOR

MOTORE MANDREL
MANDRINO MOTOR



RAVAGLIOLI S.p.A.

**LISTA DEI COMPONENTI - LIST OF COMPONENTS - TEILELISTE
LISTE DES PIÈCES DÉTACHÉES - LISTA DE PIEZAS**

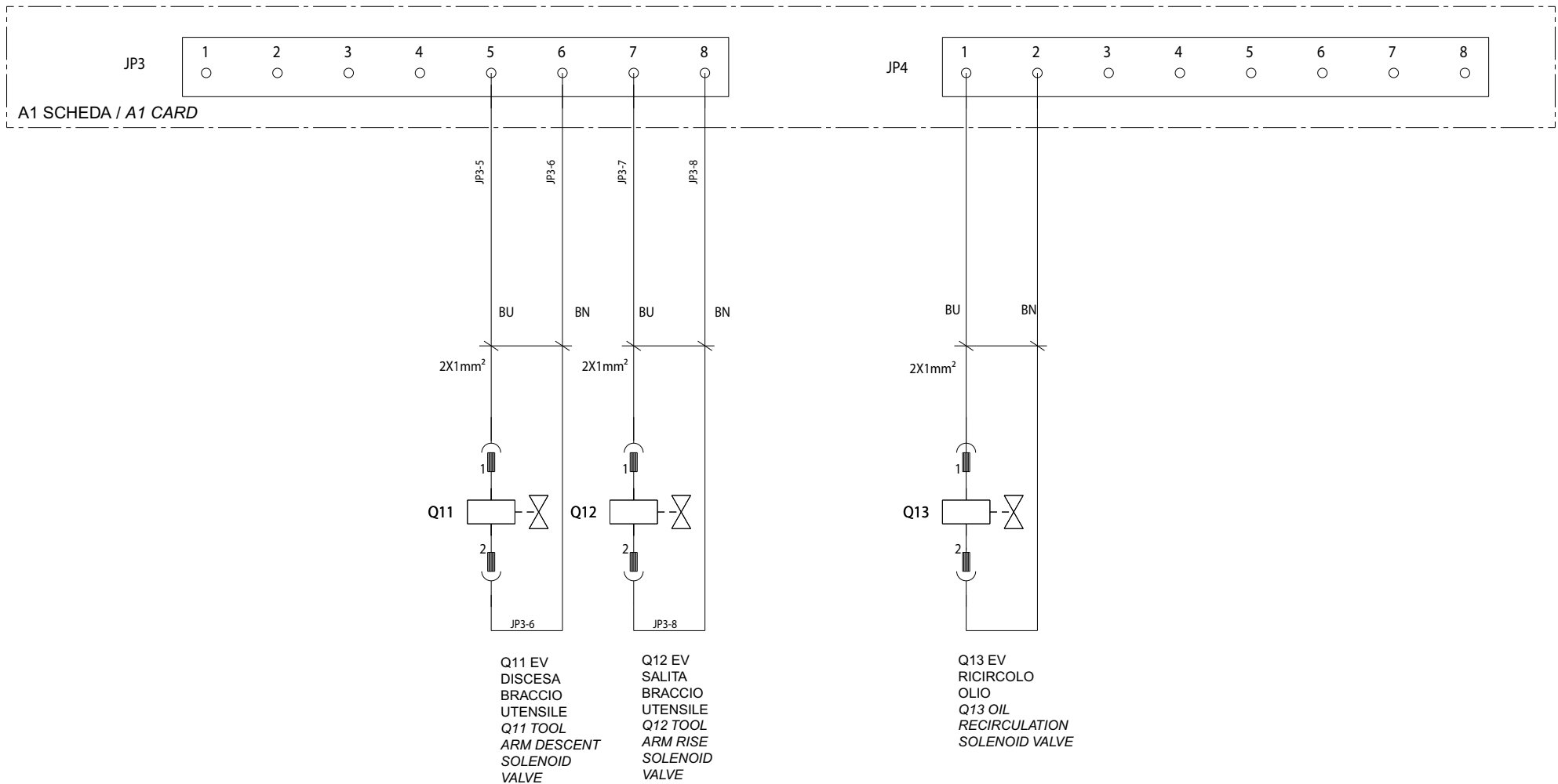
Tavola N°G - Rev. 0

752205690

SCHEMA ELETTRICO 8/19
ELECTRICAL SCHEME 8/19
SCHALTPLAN 8/19
SCHEMA ELECTRIQUE 8/19
ESQUEMA ELECTRICO 8/19
(G9256.15SL) (VARIANTE INVERTER)

Pag. 100 di 168

G9256.11SL - G9256.11ST - G9256.15 - G9256T.15
G9256A.15 - G9256D.15 - G9256TD.15 - G9256.15SL
G10360.15 - G10360T.15 - G10360A.15
G10360D.15 - G10360TD.15



RAVAGLIOLI S.p.A.

**LISTA DEI COMPONENTI - LIST OF COMPONENTS - TEILELISTE
LISTE DES PIÈCES DÉTACHÉES - LISTA DE PIEZAS**

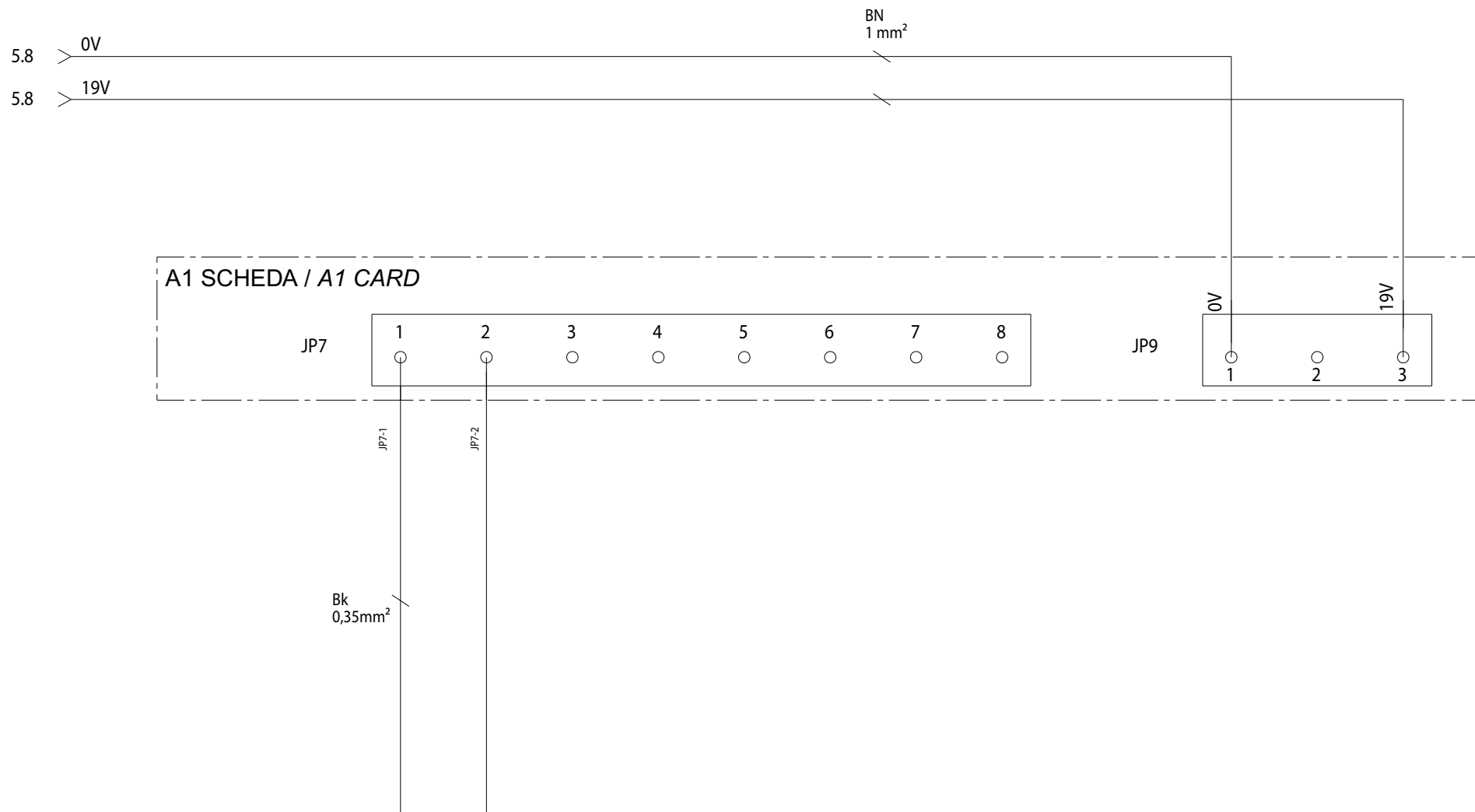
Tavola N°G - Rev. 0

752205690

SCHEMA ELETTRICO 9/19
ELECTRICAL SCHEME 9/19
SCHALTPLAN 9/19
SCHEMA ELECTRIQUE 9/19
ESQUEMA ELECTRICO 9/19
(G9256.15SL) (VARIANTE INVERTER)

Pag. 101 di 168

G9256.11SL - G9256.11ST - G9256.15 - G9256T.15
G9256A.15 - G9256D.15 - G9256TD.15 - G9256.15SL
G10360.15 - G10360T.15 - G10360A.15
G10360D.15 - G10360TD.15



RAVAGLIOLI S.p.A.

**LISTA DEI COMPONENTI - LIST OF COMPONENTS - TEILELISTE
LISTE DES PIÈCES DÉTACHÉES - LISTA DE PIEZAS**

Tavola N°G - Rev. 0

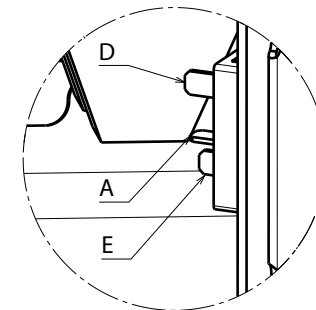
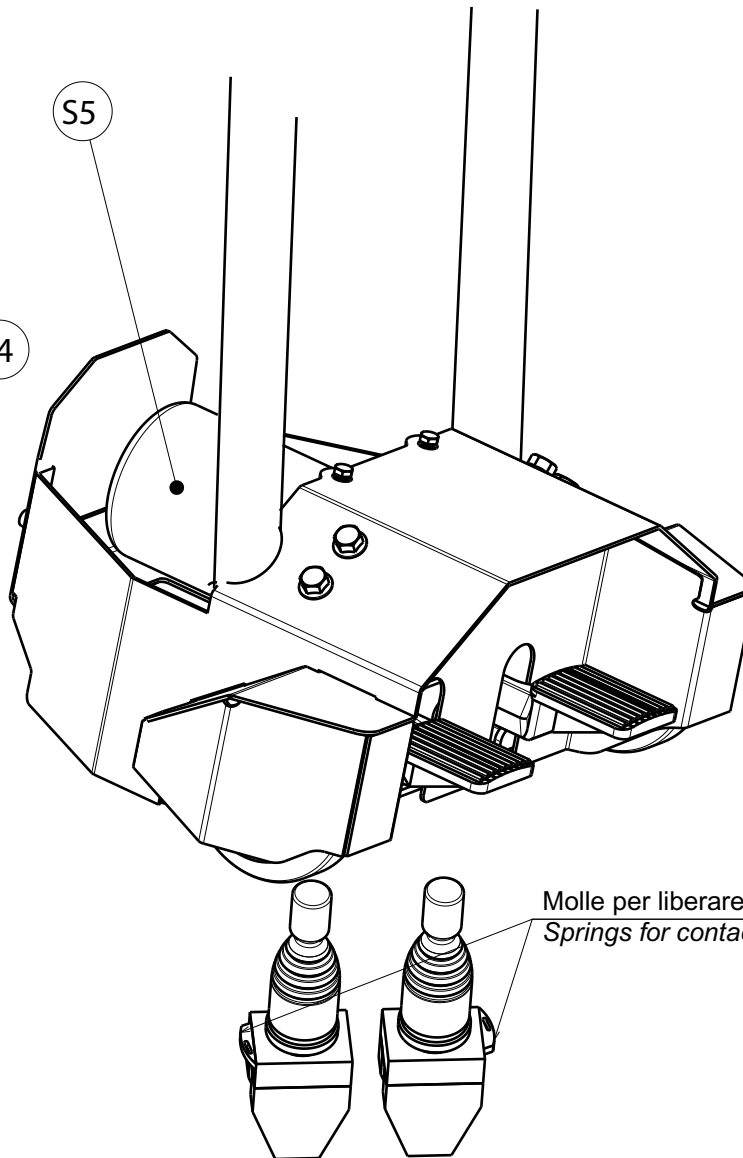
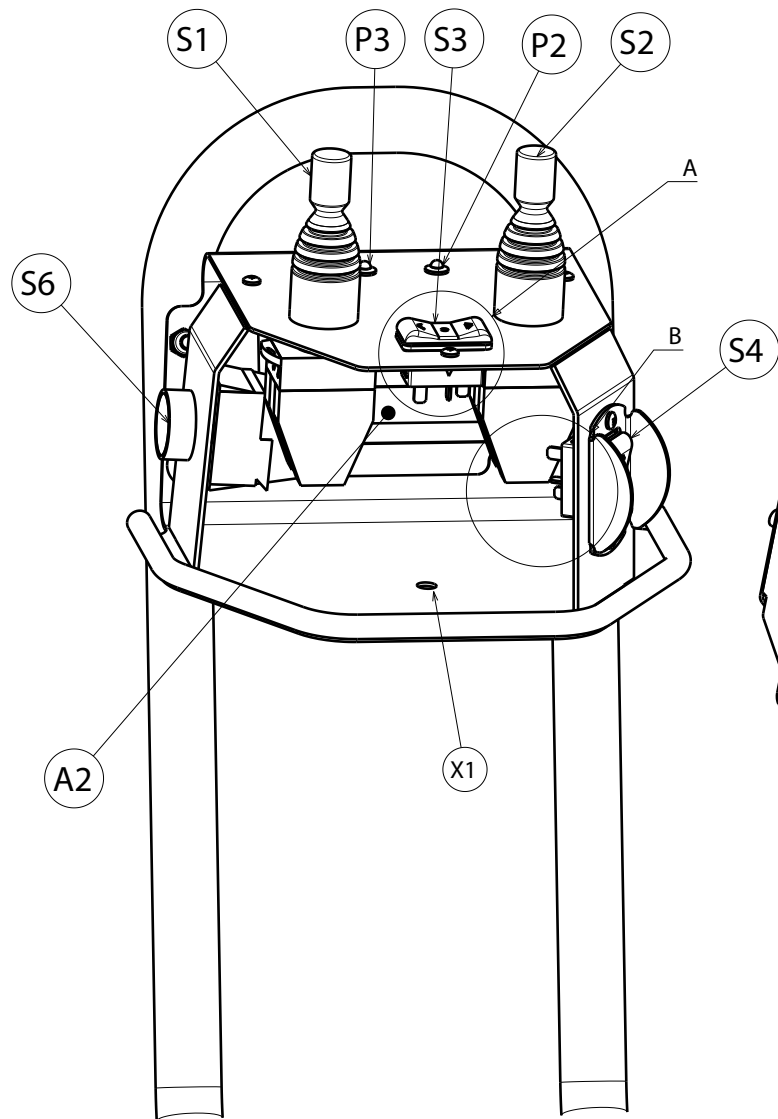
752205690

SCHEMA ELETTRICO 10/19
ELECTRICAL SCHEME 10/19
SCHALTPLAN 10/19
SCHEMA ELECTRIQUE 10/19
ESQUEMA ELECTRICO 10/19
(G9256.15SL) (VARIANTE INVERTER)

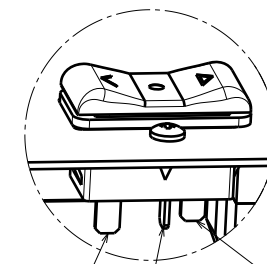
Pag. 102 di 168

G9256.11SL - G9256.11ST - G9256.15 - G9256T.15
G9256A.15 - G9256D.15 - G9256TD.15 - G9256.15SL
G10360.15 - G10360T.15 - G10360A.15
G10360D.15 - G10360TD.15

7522-M001-14_R



Dettaglio B
Detail B

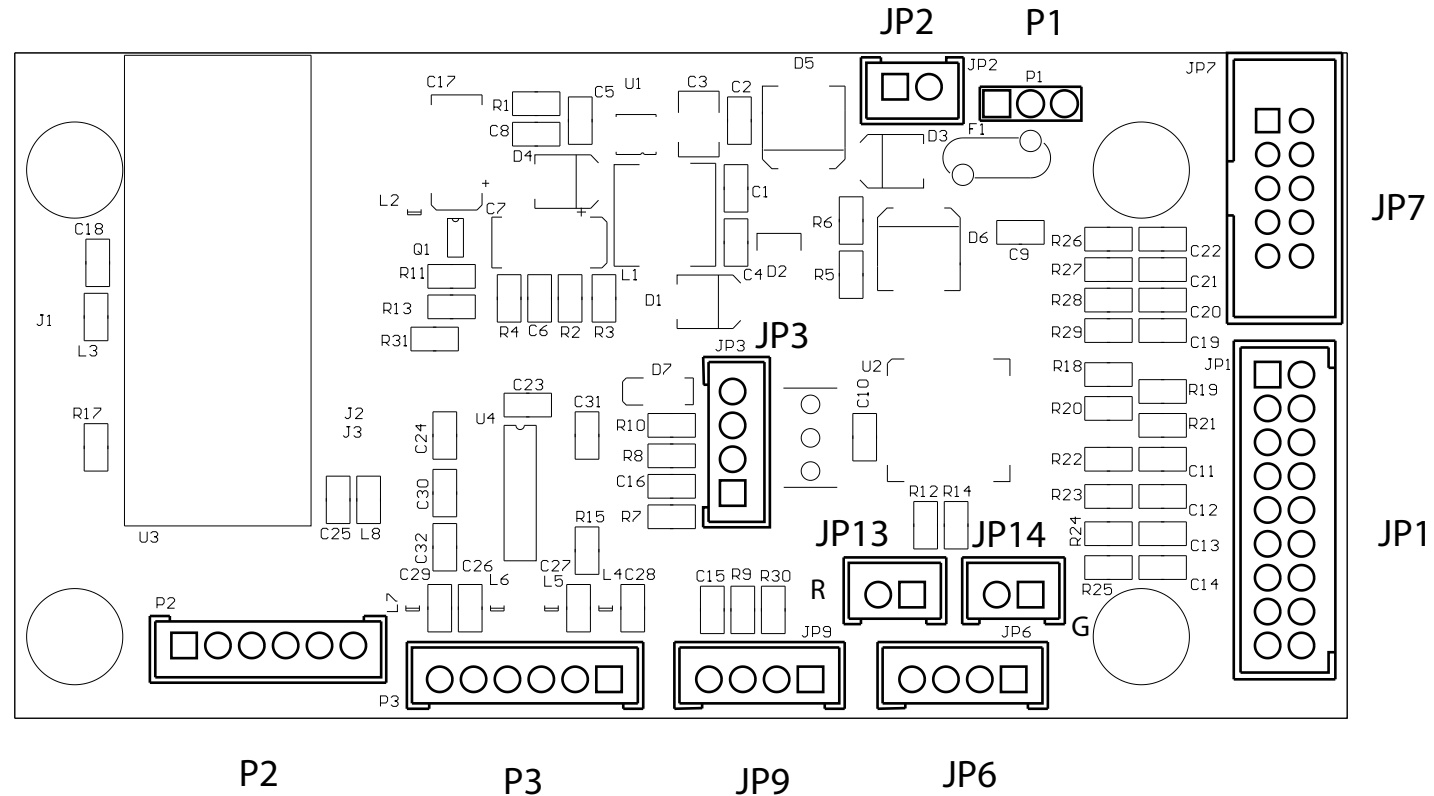


Dettaglio A
Detail A

Molle per liberare i contatti verso lati opposti
Springs for contacts release towards opposite sides

TOPOGRAFICO SCHEDA TRASMITTENTE 18961

TRANSMITTING CARD 18961 TOPOGRAPHIC VIEW



 RAVAGLIOLI S.p.A.	LISTA DEI COMPONENTI - LIST OF COMPONENTS - TEILELISTE LISTE DES PIÈCES DÉTACHÉES - LISTA DE PIEZAS		SCHEMA ELETTRICO 12/19 ELECTRICAL SCHEME 12/19 SCHALTPLAN 12/19 SCHEMA ELECTRIQUE 12/19 ESQUEMA ELECTRICO 12/19 (G9256.15SL) (VARIANTE INVERTER)	Pag. 104 di 168 <small>G9256.11SL - G9256.11ST - G9256.15 - G9256T.15 G9256A.15 - G9256D.15 - G9256TD.15 - G9256.15SL G10360.15 - G10360T.15 - G10360A.15 G10360D.15 - G10360TD.15</small>
	Tavola N°G - Rev. 0	752205690		

IN / OUT SCHEDA TRASMITTENTE 18961

TRANSMITTING CARD 18961 IN/OUT

PIN JP1	NUMERO	FUNZIONE
1	JP1-1	S1 INDIETRO CARRO MANDRINO
2	JP1-2	S2 INDIETRO CARRO UTENSILE
3	JP1-3	S1 AVANTI CARRO MANDRINO
4	JP1-4	S2 AVANTI CARRO UTENSILE
5	JP1-5	S1 SALITA BRACCIO MANDRINO
6	JP1-6	S2 DISCESA BRACCIO UTENSILE
7	JP1-7	S1 DISCESA BRACCIO MANDRINO
8	JP1-8	S2 SALITA BRACCIO UTENSILE
9	JP1-9	S1 (COMUNE)
10	JP1-10	S2 (COMUNE)
11	JP1-11	S4 (COMUNE)
12	JP1-12	N.U.
13	JP1-13	S4 PULSANTE CHIUSURA MANDRINO
14	JP1-14	N.U.
15	JP1-15	S4 PULSANTE APERTURA MANDRINO
16	JP1-16	N.U.
17	JP1-17	S3 PULS.ROTAZ.ANTIOR. UTENS.
18	JP1-18	N.U.

PIN JP6	NUMERO	FUNZIONE
1	JP6-1	S5 SELETT.ROTAZ.ANTIOR. MANDRINO
2	JP6-2	S5 SELETT. ROTAZ.ORARIA MANDRINO
3	JP6-3	S3 PULS.ROTAZ.ORARIA UTENSILE
4	JP6-4	S5 COMUNE

PIN JP2	NUMERO	FUNZIONE
1	JP2-1	G2 BATTERIA -
2	JP2-2	G2 BATTERIA +

P1	NUMERO	FUNZIONE
X1		0-12Vdc

PIN JP9	NUMERO	FUNZIONE
1	JP9-1	S6 PULS. DOPPIA VELOC. CENTR.
2	JP9-2	N.U.
3	JP9-3	S3 (COMUNE)
4	JP9-4	S6 PULS. DOPPIA VELOC. CENTR.

PIN JP13	NUMERO	FUNZIONE
1	JP13-1	P2 LED ROSSO +
2	JP13-2	P2 LED ROSSO -

PIN JP14	NUMERO	FUNZIONE
1	JP14-1	P3 LED VERDE +
2	JP14-2	P3 LED VERDE -

PIN JP1	NUMBER	FUNCTION
1	JP1-1	S1 MANDREL CARRIAGE BACKWARD
2	JP1-2	S2 TOOL CARRIAGE BACKWARD
3	JP1-3	S1 MANDREL CARRIAGE FORWARD
4	JP1-4	S2 TOOL CARRIAGE FORWARD
5	JP1-5	S1 MANDREL ARM RISE
6	JP1-6	S2 TOOL ARM DESCENT
7	JP1-7	S1 MANDREL ARM DESCENT
8	JP1-8	S2 TOOL ARM RISE
9	JP1-9	S1 (COMMON)
10	JP1-10	S2 (COMMON)
11	JP1-11	S4 (COMMON)
12	JP1-12	N.U.
13	JP1-13	S4 MANDREL CLOSING PUSHBUTTON
14	JP1-14	N.U.
15	JP1-15	S4 MANDREL OPENING PUSHBUTTON
16	JP1-16	N.U.
17	JP1-17	S3 TOOL COUNTERCLOCKWISE ROT.PUSHBUTTON
18	JP1-18	N.U.

PIN JP6	NUMBER	FUNCTION
1	JP6-1	S5 MANDREL COUNTERCLOCKWISE ROT. SELECTOR
2	JP6-2	S5 MANDREL CLOCKWISE ROT. SELECTOR
3	JP6-3	S3 TOOL CLOCKWISE ROT. PUSHBUTTON
4	JP6-4	S5 COMMON

PIN JP2	NUMBER	FUNCTION
1	JP2-1	G2 BATTERY -
2	JP2-2	G2 BATTERY +

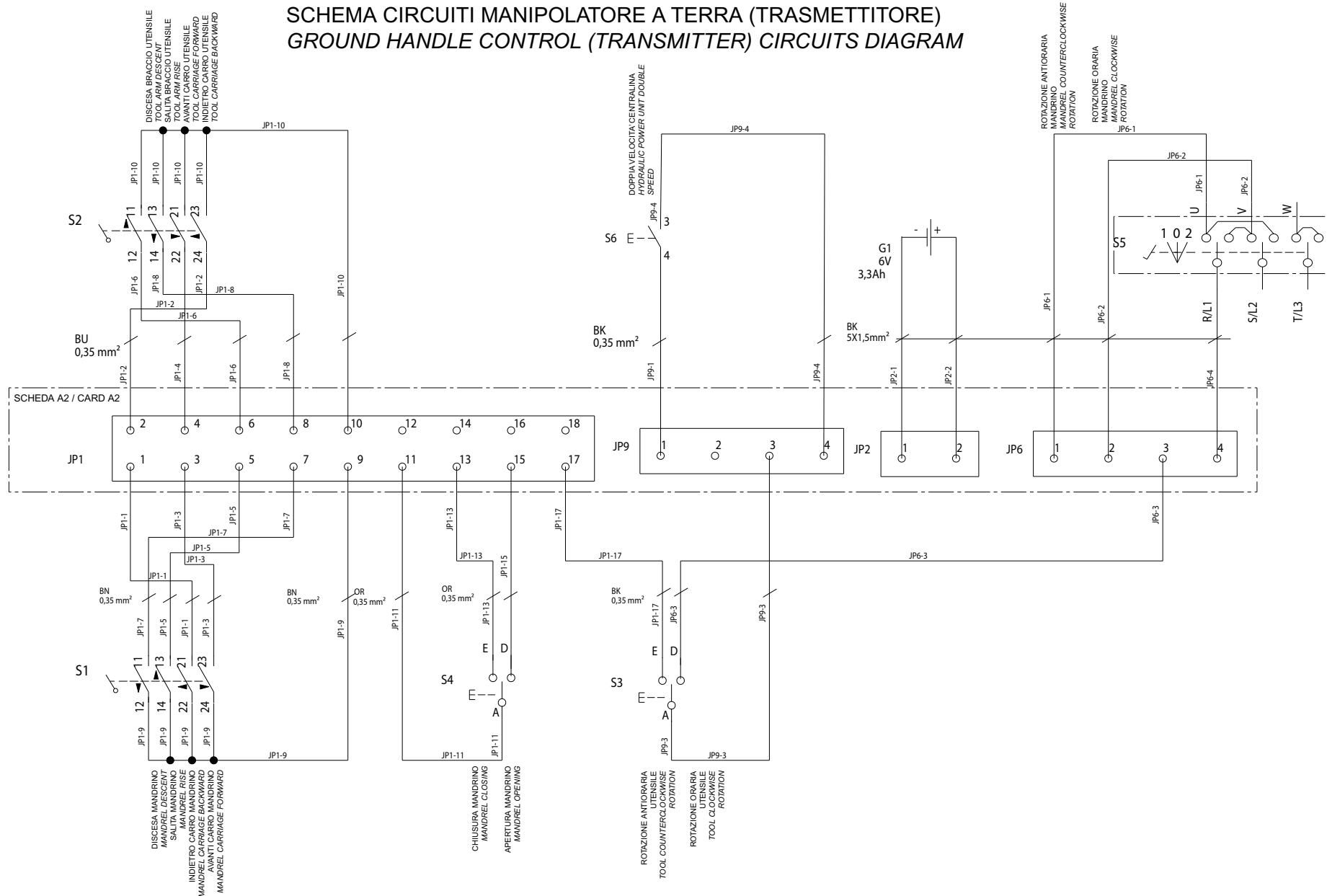
P1	NUMBER	FUNCTION
X1		0 - 12Vdc

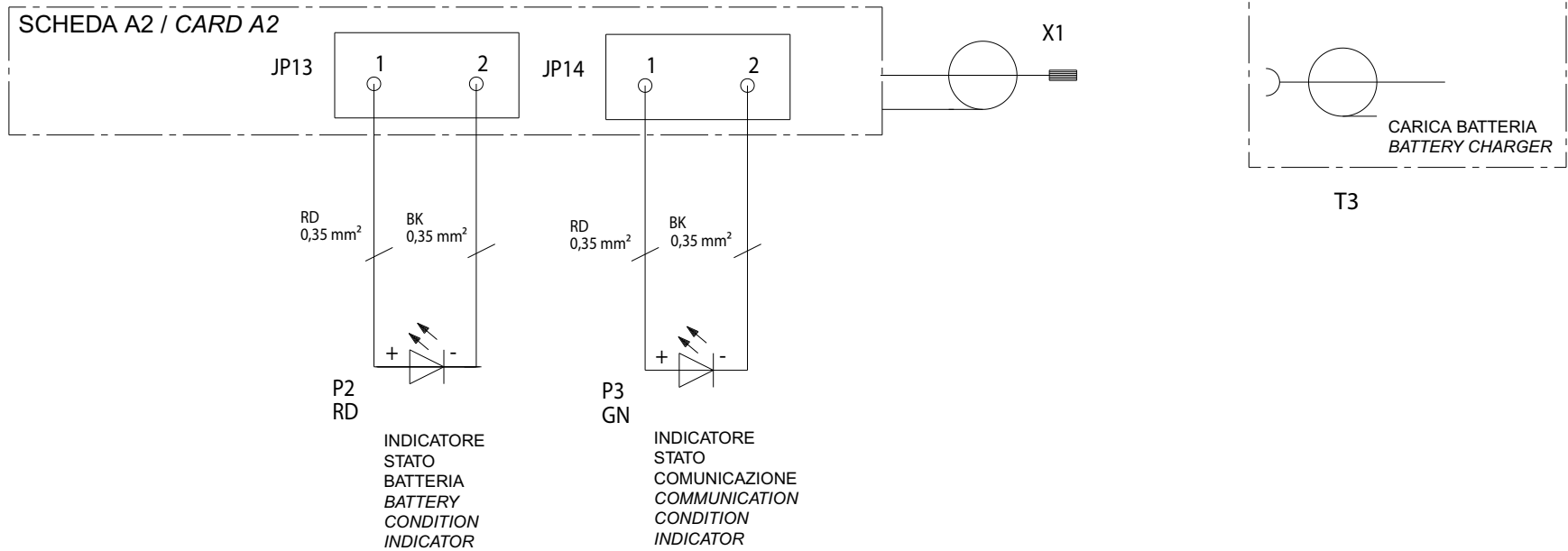
PIN JP9	NUMBER	FUNCTION
1	JP9-1	S6 HYDR. POWER UNIT DOUBLE SPEED PUSHBUTTON
2	JP9-2	N.U.
3	JP9-3	S3 (COMMON)
4	JP9-4	S6 HYDR. POWER UNIT DOUBLE SPEED PUSHBUTTON

PIN JP13	NUMBER	FUNCTION
1	JP13-1	P2 RED LED +
2	JP13-2	P2 RED LED -

PIN JP14	NUMBER	FUNCTION
1	JP14-1	P3 GREEN LED +
2	JP14-2	P3 GREEN LED -

SCHEMA CIRCUITI MANIPOLATORE A TERRA (TRASMETTITORE) GROUND HANDLE CONTROL (TRANSMITTER) CIRCUITS DIAGRAM





RAVAGLIOLI S.p.A.

**LISTA DEI COMPONENTI - LIST OF COMPONENTS - TEILELISTE
LISTE DES PIÈCES DÉTACHÉES - LISTA DE PIEZAS**

Tavola N°G - Rev. 0

752205690

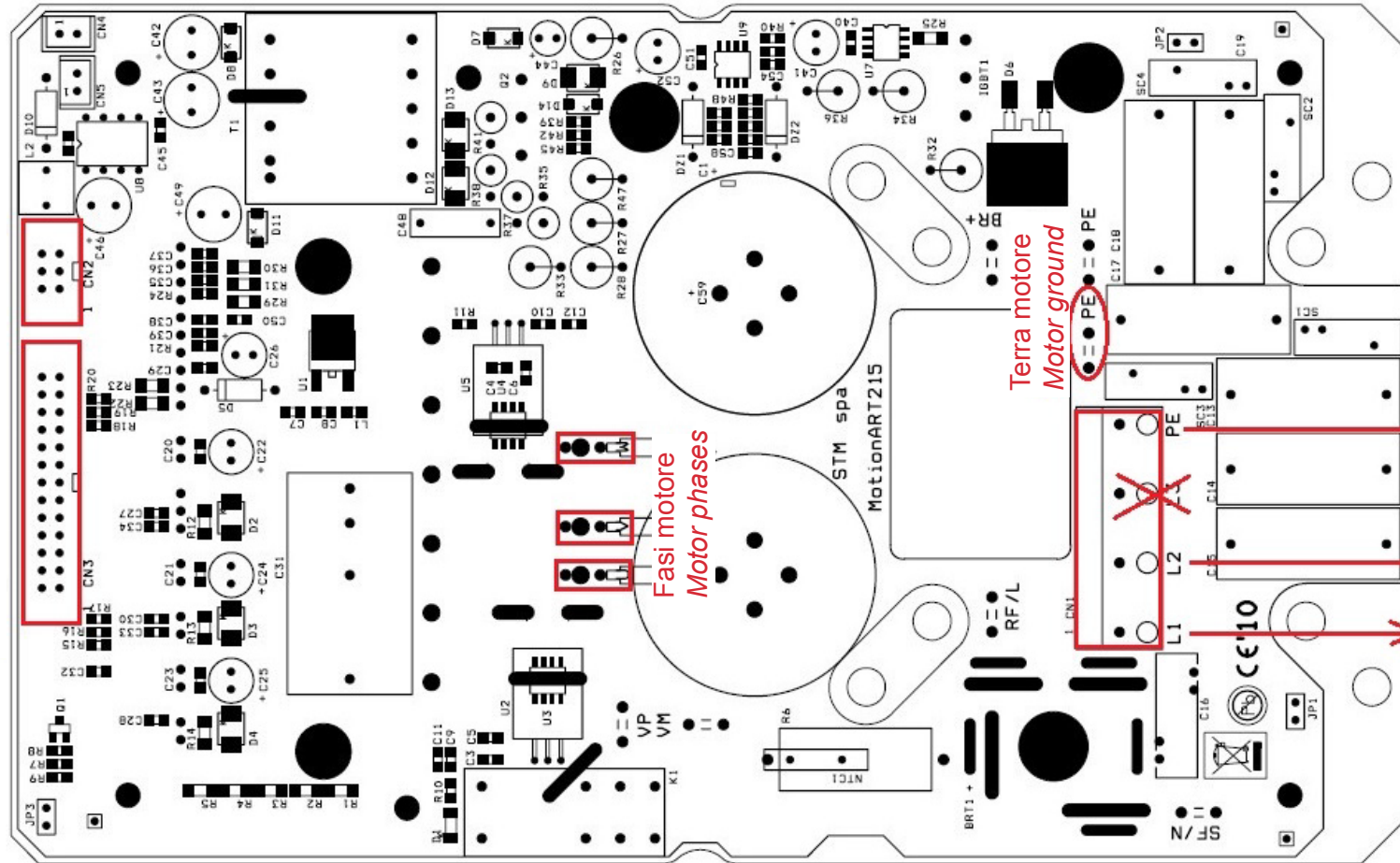
SCHEMA ELETTRICO 15/19
ELECTRICAL SCHEME 15/19
SCHALTPLAN 15/19
SCHEMA ELECTRIQUE 15/19
ESQUEMA ELECTRICO 15/19
(G9256.15SL) (VARIANTE INVERTER)

Pag. 107 di 168

G9256.11SL - G9256.11ST - G9256.15 - G9256T.15
G9256A.15 - G9256D.15 - G9256TD.15 - G9256.15SL
G10360.15 - G10360T.15 - G10360A.15
G10360D.15 - G10360TD.15

DISEGNO TOPOGRAFICO SCHEDA INVERTER - LAYER 1
 INVERTER CARD TOPOGRAPHICAL DRAWING - LAYER 1

collegamenti verso la scheda di logica
 connections towards logic card



Terra motore
 Motor ground

Fasi motore
 Motor phases

Terra
 Ground

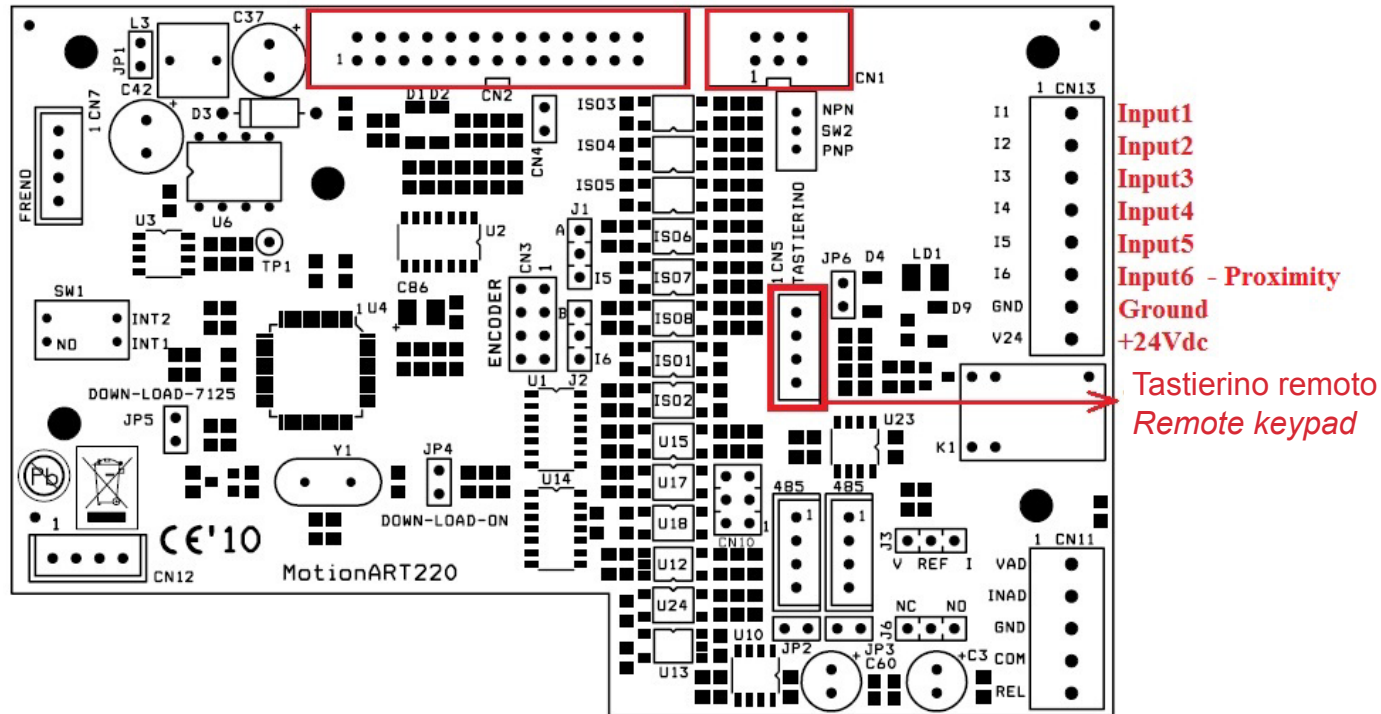
Fase
 Phase

Neutro
 Neutral

Alimentazione 220 Vac
 220 Vac supply voltage

DISEGNO TOPOGRAFICO SCHEDA INVERTER - LAYER 2 INVERTER CARD TOPOGRAPHICAL DRAWING - LAYER 2

collegamenti verso la scheda di potenza
connections towards power card



LISTA COMPONENTI

RIFERIMENTO	DESCRIZIONE	DATI TECNICI	SIGLA CATALOGO	QUANTITA	RIFERIMENTO DOCUMENTO
A1	SCHEDA ELETT. RICEVENTE	-	18962	1	2.5
A2	SCHEDA ELETT.TRASMITTENTE	-	18961	1	11.2
F2	INTERRUTTORE AUTOM. TRIPOLARE	6,3-10A AC3 400V 2,2KW	518277	1	6.2
	CONTATTI AUSILIARI	1NO+1NC ATTACCO FRONTALE	518279	1	6.2
F3	PORTAFUSIBILE	2 POLI SEZIONABILE 10,3x38 32A 690V	515027	1	5.3
	FUSIBILE	10,3X38 2A 500V RAPIDO	507019	2	
F4	FUSIBILE	5x20F 250V 2A RAPIDO	507043	1	5.3
F5	FUSIBILE	5x20F 250V 8A RAPIDO	507090	1	5.3
F6	FUSIBILE	5X20 T 8A 250V	507118	1	5.7
G1	BATTERIA	6V 3,3AH/20HR Lead	10066	1	14.6
K3	CONTATTORE TRIPOLARE	9A AC3 400V 4,2KW 1NC 24Vac 50/60Hz	522137	1	7.5
K4	CONTATTORE TRIPOLARE	9A AC3 400V 4,2KW 1NC 24Vac 50/60Hz	522137	1	7.5
	CONTATTI AUSILIARI	1NO+1NC ATTACCO FRONTALE	522147	1	7.4
K5	CONTATTORE	9A AC3 400V 4,2KW 1NC 24Vac 50/60Hz	522137	1	7.4
P2	INDICATORE LUMINOSO (LED)	ROSSO	18065	1	15.4
P3	INDICATORE LUMINOSO (LED)	VERDE	18066	1	15.5
Q1...Q13	ELETTROVALVOLE	-	-	13	8-9
Q14	SEZIONATORE TRIPOLARE	1th 32A Ui 690V-50Hz Uimp 4KW	518223+518226	1	5.2
Q15	COMM. 3POS. 25A	25A 400V	518270	1	6.7
S1	MANIPOLATORE	4 POS.+CENTR.TEMPORANEE Ø22	517157AS	1	14.2
S2	MANIPOLATORE	4 POS.+CENTR.TEMPORANEE Ø22	517157AS	1	14.2
S3	PULSANTE BASCULANTE	-	517283	1	14.5
S4	PULSANTE BASCULANTE	-	517283	1	14.4
S5	COMMUTATORE	1th 25A Ui 690V-50Hz Uimp 4KW	518058	1	14.7-14.8
S6	PULSANTE	-	517105AS	1	14.5
T1	TRASFORMATORE	200 VA 50/60 Hz PRI: 0/230/400V SEC: 0/19V 8,95A 0/24V 1,25A	528056	1	5.3
-	-	-	-	-	-
T3	CARICABATTERIA	21.6W 7.2V 3A Lithium ion	18064	1	15.6
M1	MOTORE CENTRALINA NAV63.15 NAV43.15	1,85/2,5KW 400V 50HZ 4,9/7,7A cosØ=0,73/0,70 1400/2800 rpm	900003880	1	6.3
M2	MOTORE MANDRINO	2,2KW 160/277V 50Hz 7.8/13.5A cosØ=0,78 1400rpm.	900004320	1	6.5
I1	INVERTER 43 400 (x NAV43.15)		752229790	1	6.4
	INVERTER 63 500 (x NAV63.15)		752229780	1	6.4
KA1	RELE' 2 CONTATTI 8A 24VAC		557017	1	6.5
	ZOCCOLO A 2 CONTATTI		557018	1	6.6
KA2	RELE' 2 CONTATTI 8A 24VAC		557017	1	6.6
	ZOCCOLO A 2 CONTATTI		557018	1	6.6
V1	VENTILATORE ASS.120X120 230V	120x120 230V	16718	1	6.3



RAVAGLIOLI S.p.A.

**LISTA DEI COMPONENTI - LIST OF COMPONENTS - TEILELISTE
LISTE DES PIECES DETACHEES - LISTA DE PIEZAS**

Tavola N°G - Rev. 0

752205690

SCHEMA ELETTRICO 18/19
ELECTRICAL SCHEME 18/19
SCHALTPLAN 18/19

SCHEMA ELECTRIQUE 18/19
ESQUEMA ELECTRICO 18/19
(G9256.15SL) (VARIANTE INVERTER)

Pag. 110 di 168

G9256.11SL - G9256.11ST - G9256.15 - G9256T.15
G9256A.15 - G9256D.15 - G9256TD.15 - G9256.15SL
G10360.15 - G10360T.15 - G10360A.15
G10360D.15 - G10360TD.15

7522-M001-14_R

COMPONENTS LIST

REFERENCE	DESCRIPTION	TECHNICAL SPECIFICATIONS	ABBREVIATION ON CATALOGUE	QUANTITY	DOCUMENT REFERENCE
A1	RECEIVING ELECTRICAL CARD	-	18962	1	2.5
A2	TRANSMITTING ELECTRICAL CARD	-	18961	1	11.2
F2	TRIPOLAR AUTOMATIC SWITCH	6,3-10A AC3 400V 2,2KW	518277	1	6.2
	AUXILIARY CONTACTS	1NO+1NC FRONT COUPLING	518279	1	6.2
F3	FUSE HOLDER	10,3x38 32A 690V 2 POLES SECTIONABLE	515027	1	5.3
	FUSE	10,3x38 2A 500V RAPID	507019	2	
F4	FUSE	5x20F 250V 2A RAPID	507043	1	5.3
F5	FUSE	5x20F 250V 8A RAPID	507090	1	5.3
F6	FUSE	5X20 T 8A 250V	507118	1	5.7
G1	BATTERY	6V 3,3AH/20HR Lead	10066	1	14.6
K3	TRIPOLAR CONTACTOR	9A AC3 400V 4,2KW 1NC 24Vac 50/60Hz	522137	1	7.5
K4	TRIPOLAR CONTACTOR	9A AC3 400V 4,2KW 1NC 24Vac 50/60Hz	522137	1	7.5
	AUXILIARY CONTACTS	1NO+1NC FRONT COUPLING	522147	1	7.4
K5	CONTACTOR	9A AC3 400V 4,2KW 1NC 24Vac 50/60Hz	522137	1	7.4
P2	BACKLIGHTED INDICATOR (LED)	RED	18065	1	15.4
P3	BACKLIGHTED INDICATOR (LED)	GREEN	18066	1	15.5
Q1...Q13	SOLENOID VALVES	-	-	13	8-9
Q14	TRIPOLAR KNIFE SWITCH	Ith 32A Ui 690V-50Hz Uimp 4KW	518223+518226	1	5.2
Q15	COMM. 3POS. 25A	25A 400V	518270	1	6.7
S1	HANDLE CONTROL	4 POS.+ CENTRAL POS. TEMPORARY Ø 22	517157AS	1	14.2
S2	HANDLE CONTROL	4 POS.+ CENTRAL POS. TEMPORARY Ø 22	517157AS	1	14.2
S3	BALANCING PUSHBUTTON	-	517283	1	14.5
S4	BALANCING PUSHBUTTON	-	517283	1	14.4
S5	COMMUTATOR	Ith 25A Ui 690V-50Hz Uimp 4KW	518058	1	14.7-14.8
S6	PUSHBUTTON	-	517105AS	1	14.5
T1	TRANSFORMER	200 VA 50/60 Hz PRI: 0/230/400V SEC: 0/19V 8,95A 0/24V 1,25A	528056	1	5.3
-	-	-	-	-	-
T3	BATTERY CHARGER	21.6W 7.2V 3A Lithium ion	18064	1	15.6
M1	HYDRAULIC POWER UNIT MOTOR	1,85/2,5KW 400V 50HZ 4,9/7,7A cosØ=0,73/0,70 1400/2800 rpm	900003880	1	6.3
M2	MANDREL MOTOR	2,2KW 160/277V 50Hz 7.8/13.5A cosØ=0,78 1400rpm.	900004320	1	6.5
I1	INVERTER 43 400		752229790	1	6.4
	INVERTER 63 500		752229780	1	6.4
KA1	2 CONTACTS RELAY 8A 24 VAC		557017	1	6.5
	2 CONTACTS BASE		557018	1	6.6
KA2	2 CONTACTS RELAY 8A 24 VAC		557017	1	6.6
	2 CONTACTS BASE		557018	1	6.6
V1	FAN 120X120 230V	120x120 230V	16718	1	6.3



RAVAGLIOLI S.p.A.

**LISTA DEI COMPONENTI - LIST OF COMPONENTS - TEILELISTE
LISTE DES PIÈCES DÉTACHÉES - LISTA DE PIEZAS**

Tavola N°G - Rev. 0

752205690

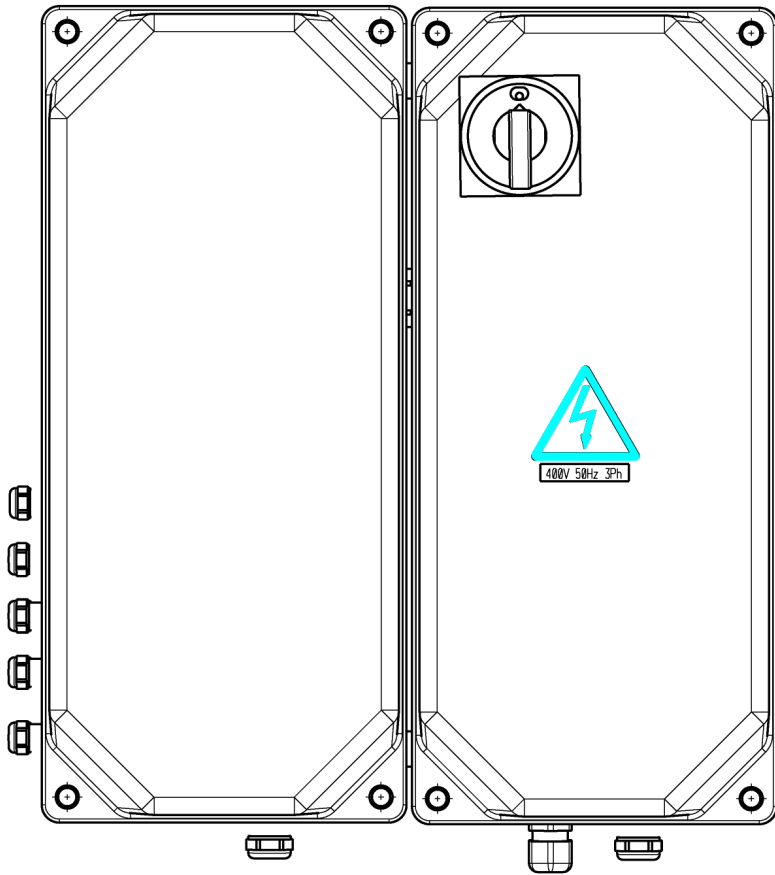
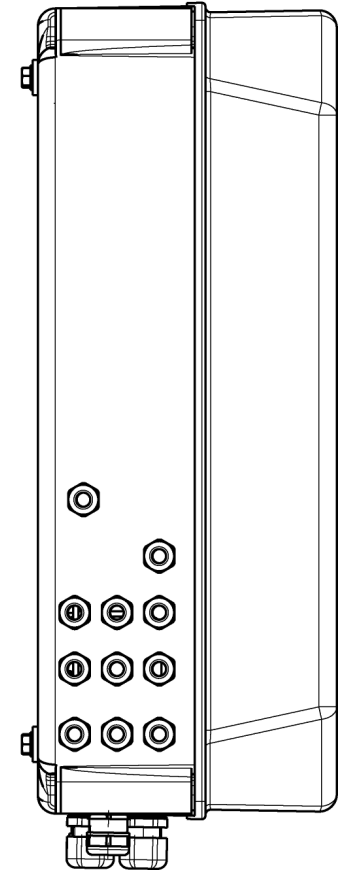
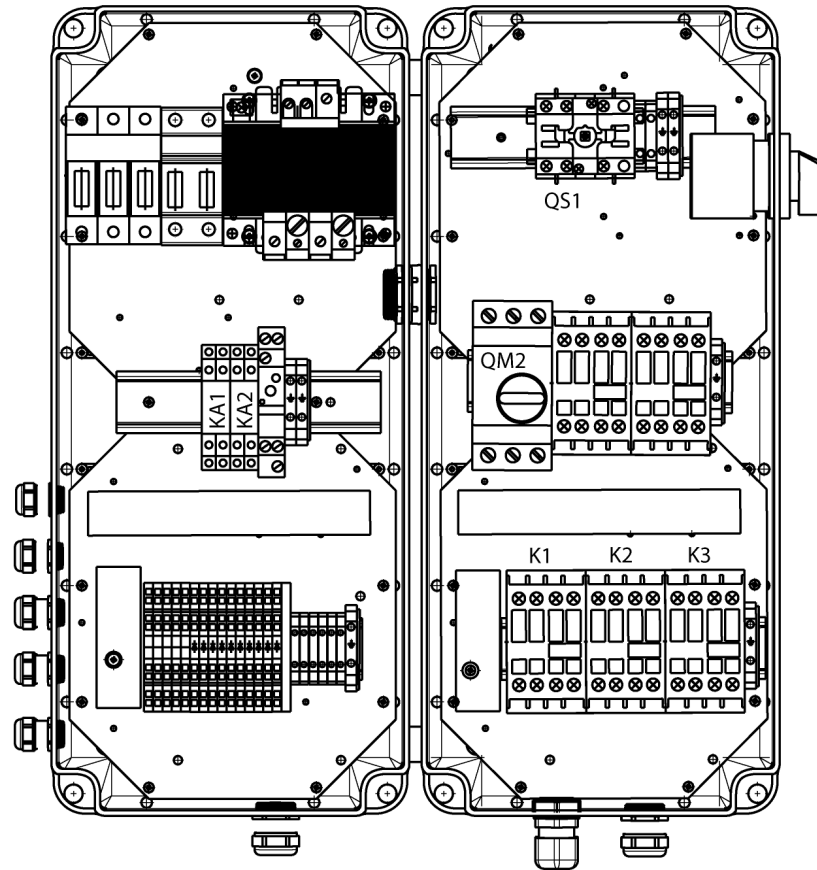
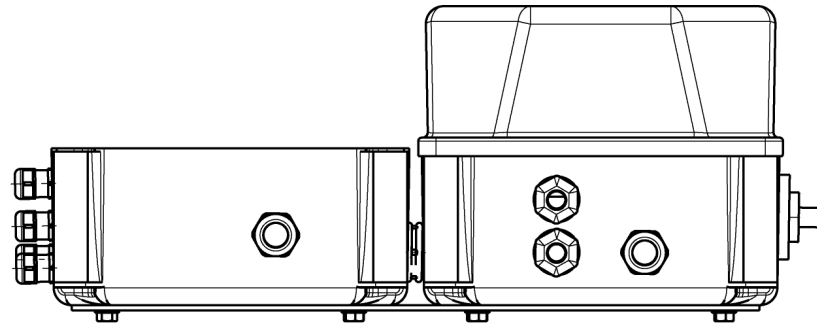
SCHEMA ELETTRICO 19/19
ELECTRICAL SCHEME 19/19
SCHALTPLAN 19/19

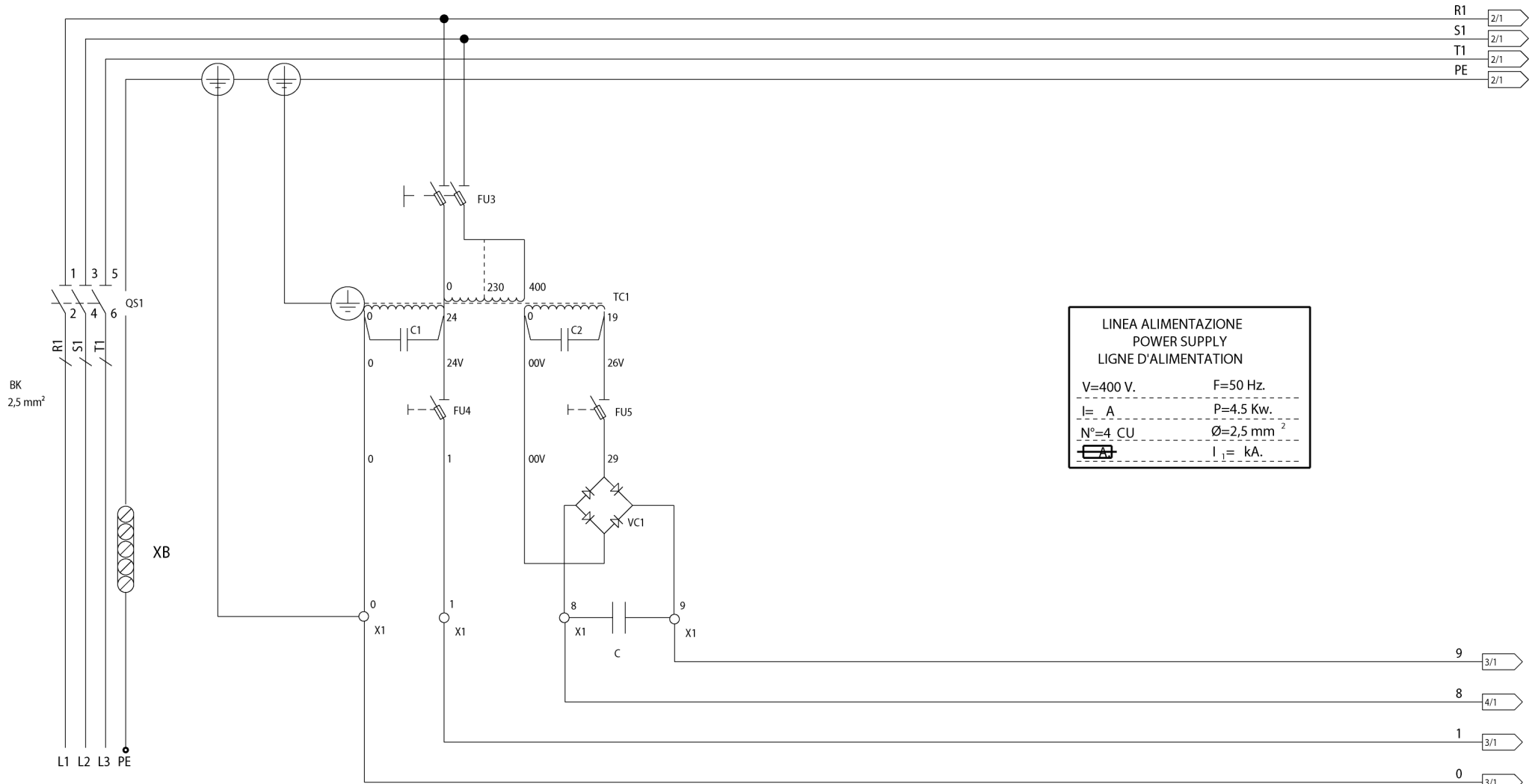
SCHEMA ELECTRIQUE 19/19
ESQUEMA ELECTRICO 19/19
(G9256.15SL) (VARIANTE INVERTER)

Pag. 111 di 168

G9256.11SL - G9256.11ST - G9256.15 - G9256T.15
G9256A.15 - G9256D.15 - G9256TD.15 - G9256.15SL
G10360.15 - G10360T.15 - G10360A.15
G10360D.15 - G10360TD.15

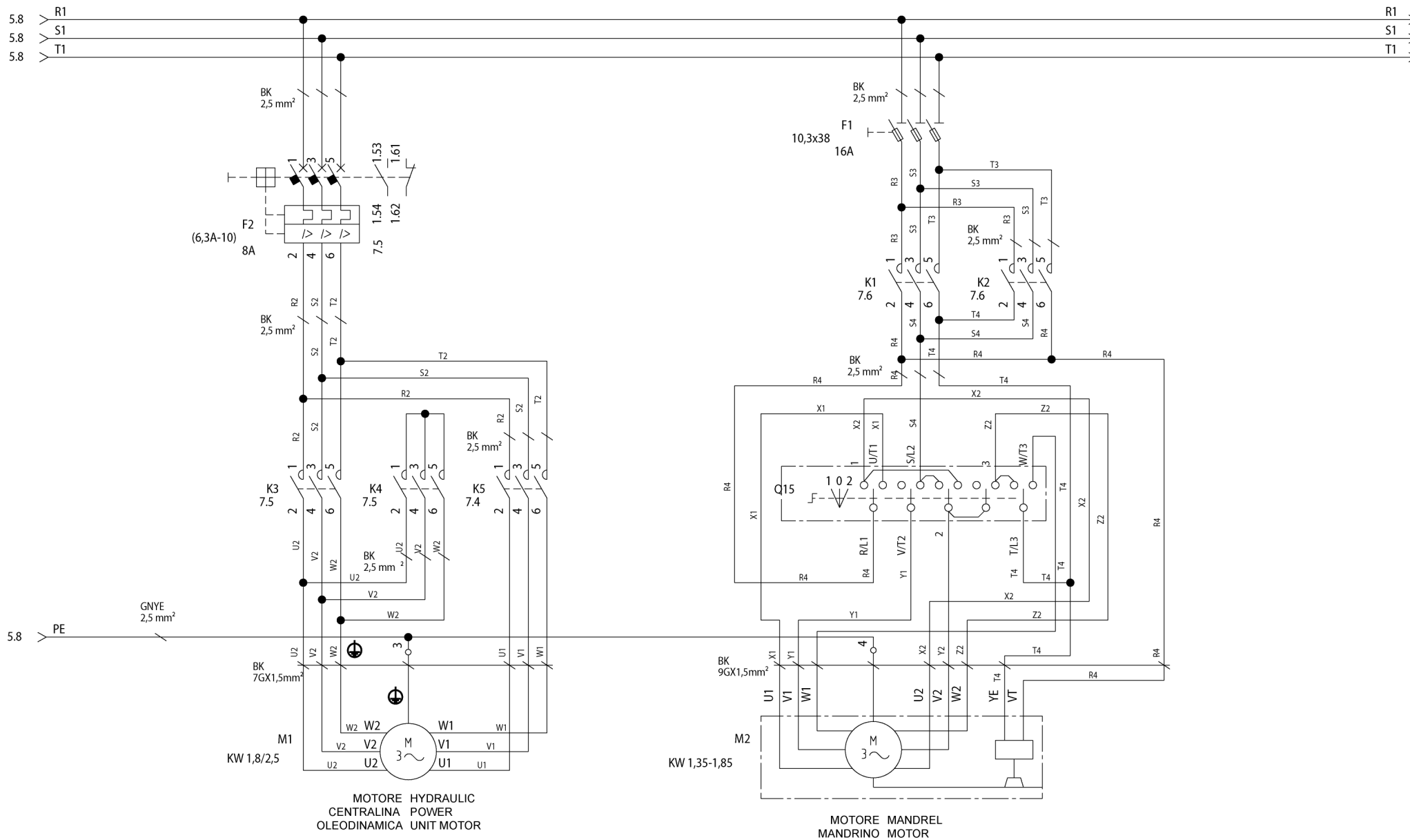
7522-M001-14_R





ALIMENTAZIONE AUSILIARI 24VAC
AUXILIARIES SUPPLY 24VAC

ALIMENTAZIONE AUSILIARI 27VDC
AUXILIARIES SUPPLY 27VDC



RAVAGLIOLI S.p.A.

LISTA DEI COMPONENTI - LIST OF COMPONENTS - TEILELISTE
LISTE DES PIÈCES DÉTACHÉES - LISTA DE PIEZAS

Tavola N°H - Rev. 0

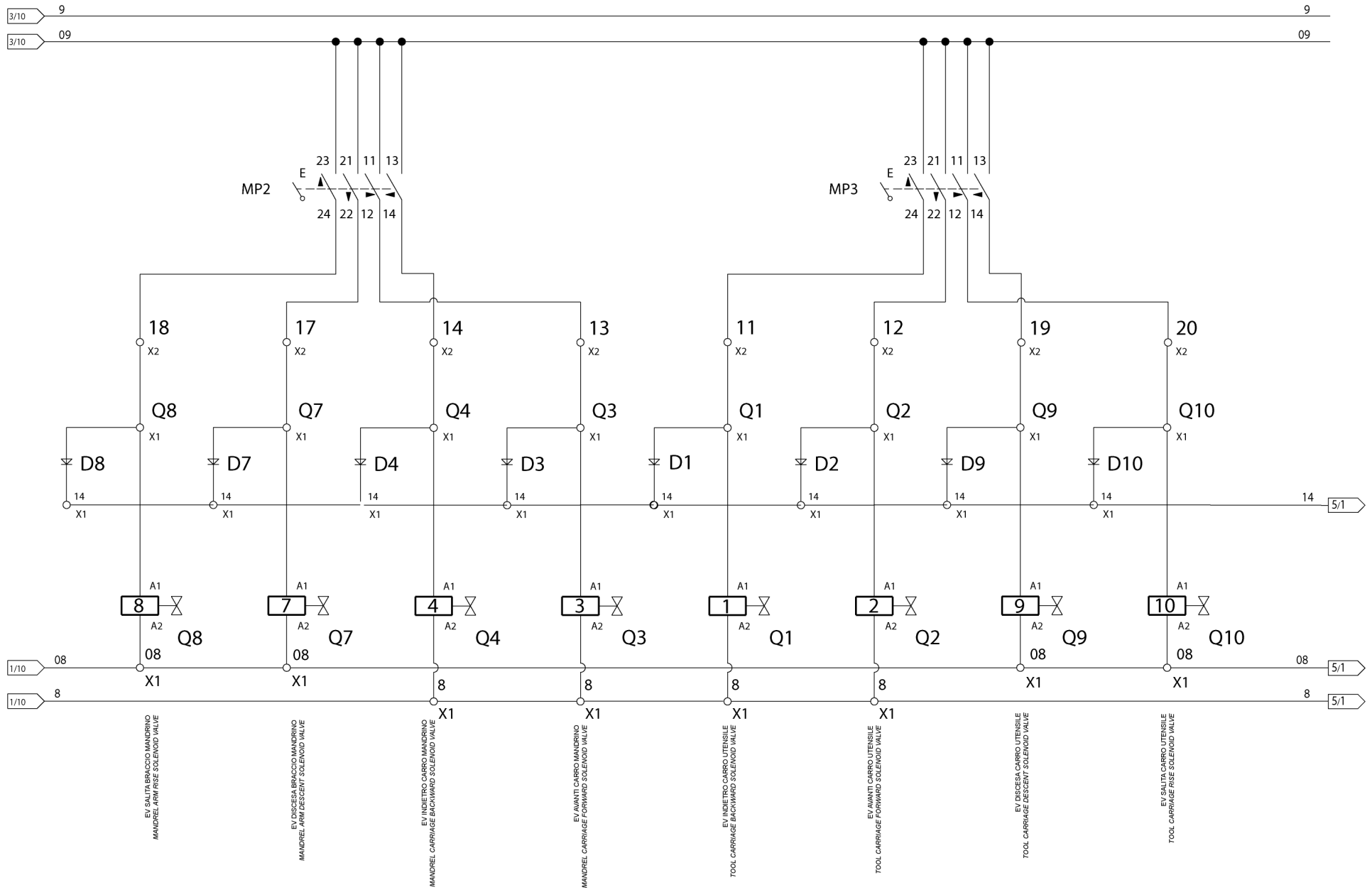
752205730

SCHEMA ELETTRICO 3/9
ELECTRICAL SCHEME 3/9
SCHALTPLAN 3/9
SCHEMA ELECTRIQUE 3/9
ESQUEMA ELECTRICO 3/9
(G9256.11SL - G9256.15SL (VARGNAV43ASL))

Pag. 114 di 168

G9256.11SL - G9256.11ST - G9256.15 - G9256T.15
G9256A.15 - G9256D.15 - G9256TD.15 - G9256.15SL
G10360.15 - G10360T.15 - G10360A.15
G10360D.15 - G10360TD.15

7522-M001-14_R



EV SALITA BRACCIO MANDRINO
MANDREL ARM RISE SOLENOID VALVE

EV DISCESA BRACCIO MANDRINO
MANDREL ARM DESCENT SOLENOID VALVE

EV INDIETRO CARRO MANDRINO
MANDREL CARRIAGE BACKWARD SOLENOID VALVE

EV AVANTI CARRO MANDRINO
MANDREL CARRIAGE FORWARD SOLENOID VALVE

EV INDIETRO CARRO UTENSILE
TOOL CARRIAGE BACKWARD SOLENOID VALVE

EV AVANTI CARRO UTENSILE
TOOL CARRIAGE FORWARD SOLENOID VALVE

EV DISCESA CARRO UTENSILE
TOOL CARRIAGE DESCENT SOLENOID VALVE

EV SALITA CARRO UTENSILE
TOOL CARRIAGE RISE SOLENOID VALVE



RAVAGLIOLI S.p.A.

LISTA DEI COMPONENTI - LIST OF COMPONENTS - TEILELISTE
LISTE DES PIÈCES DÉTACHÉES - LISTA DE PIEZAS

Tavola N°H - Rev. 0

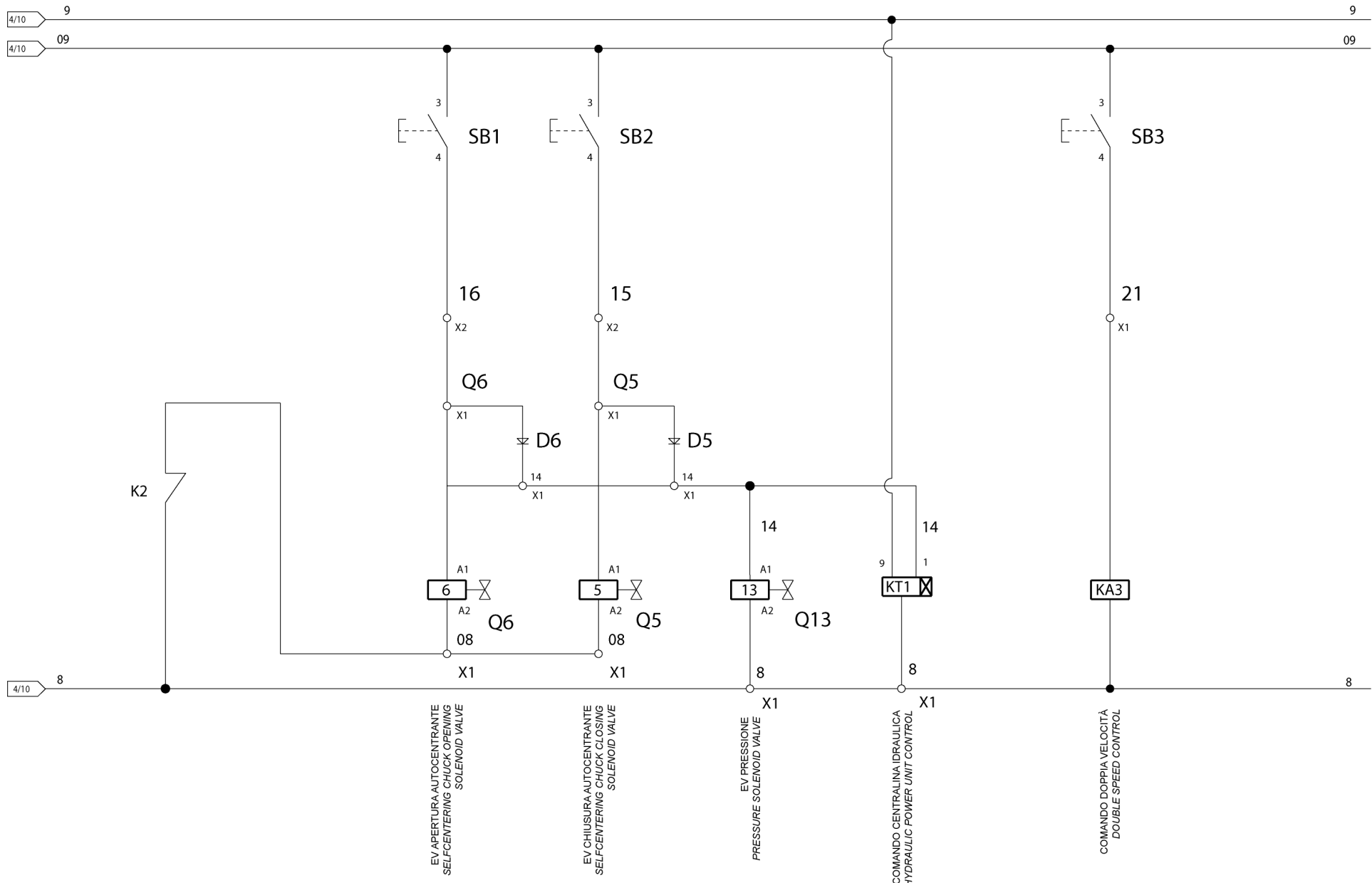
752205730

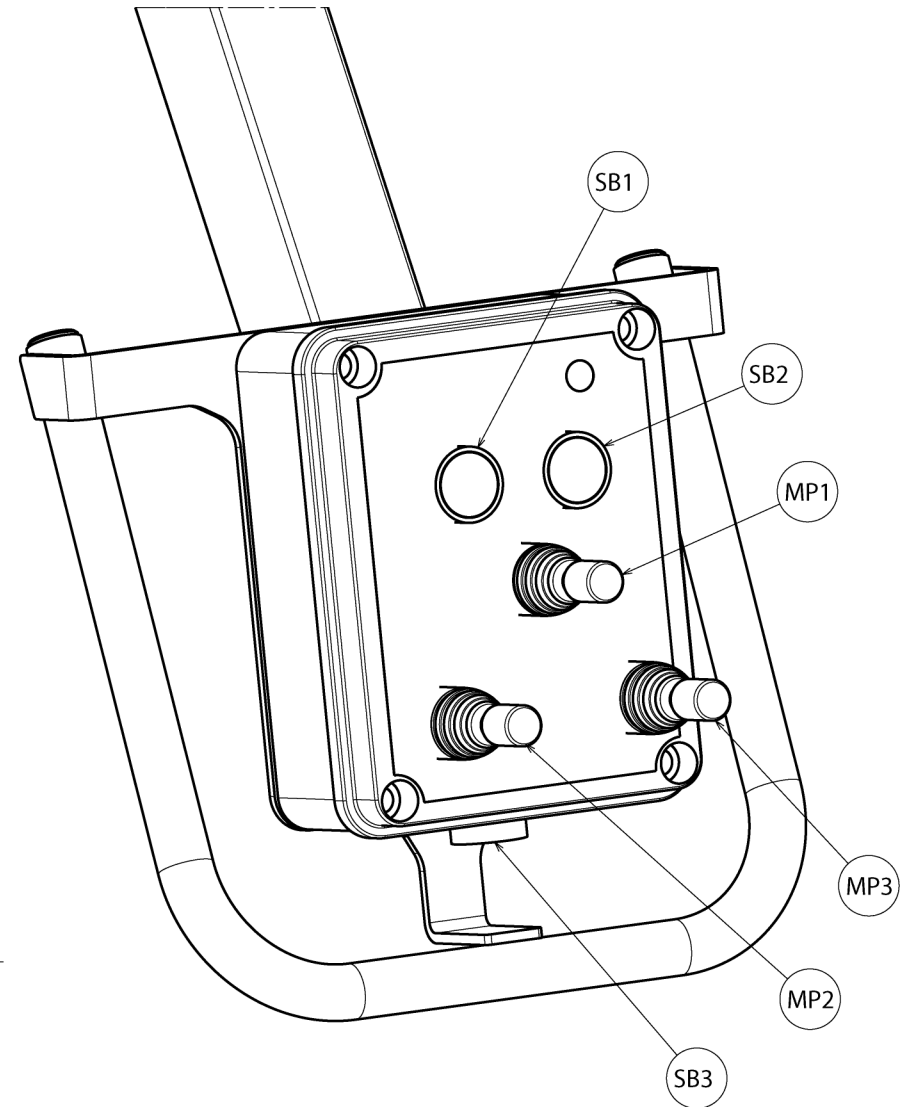
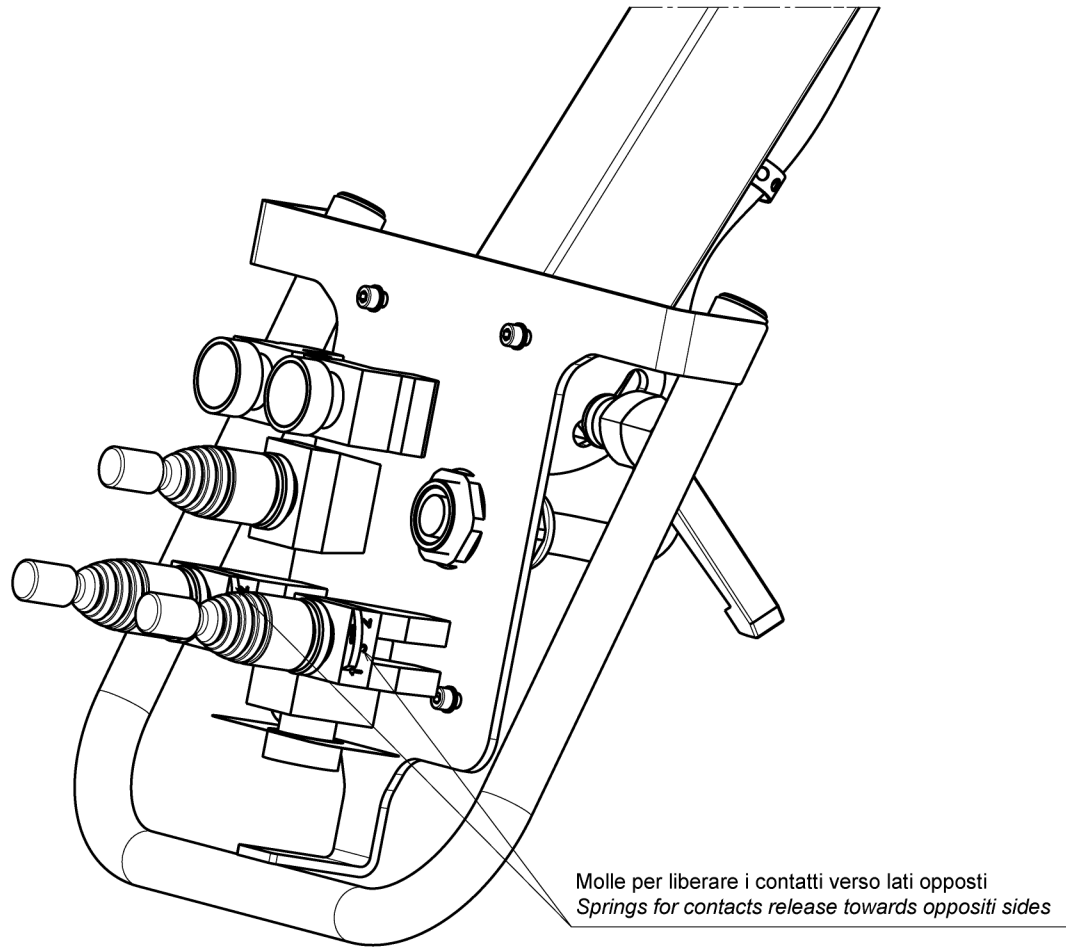
SCHEMA ELETTRICO 5/9
ELECTRICAL SCHEME 5/9
SCHALTPLAN 5/9
SCHEMA ELECTRIQUE 5/9
ESQUEMA ELECTRICO 5/9
(G9256.11SL - G9256.15SL (VARGNAV43ASL))

Pag. 116 di 168

G9256.11SL - G9256.11ST - G9256.15 - G9256T.15
G9256A.15 - G9256D.15 - G9256TD.15 - G9256.15SL
G10360.15 - G10360T.15 - G10360A.15
G10360D.15 - G10360TD.15

7522-M001-14_R



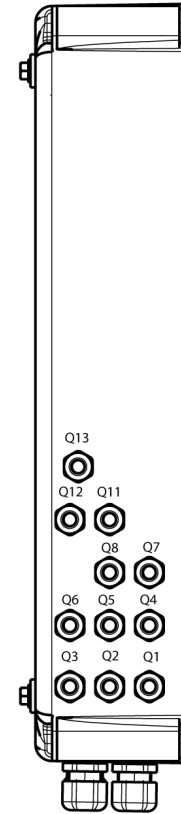
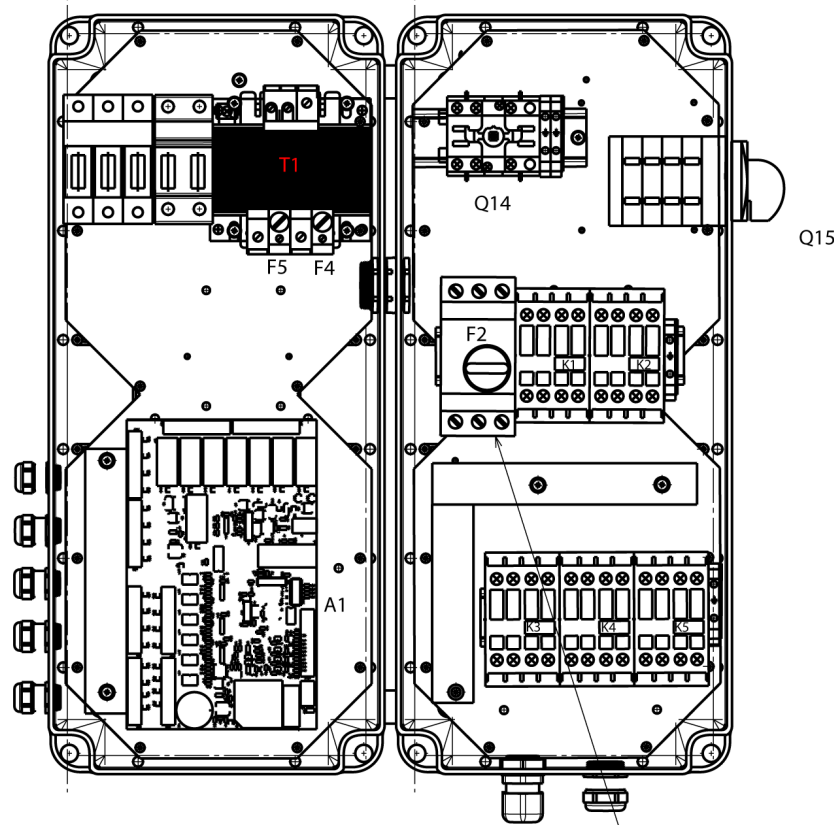
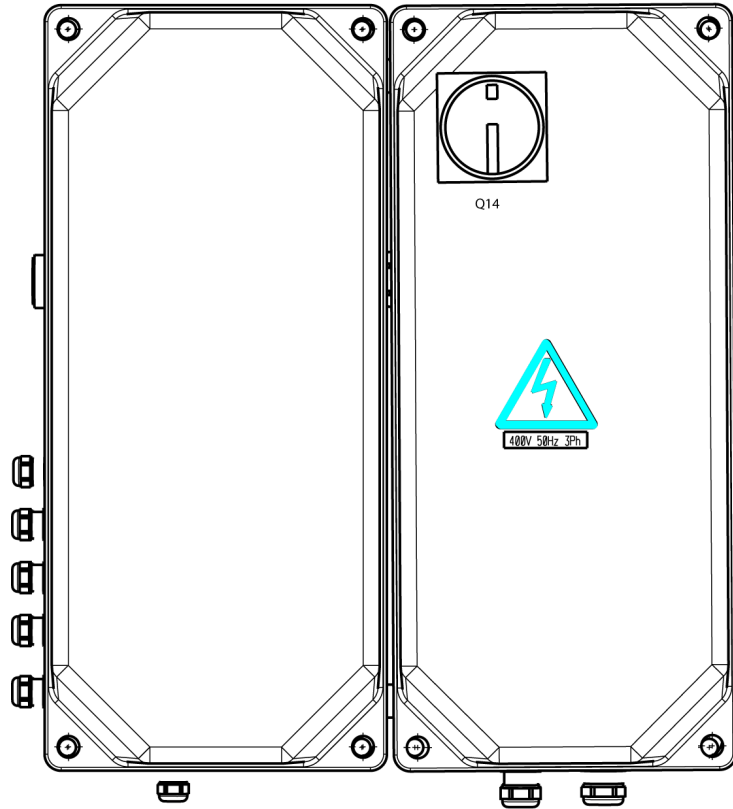
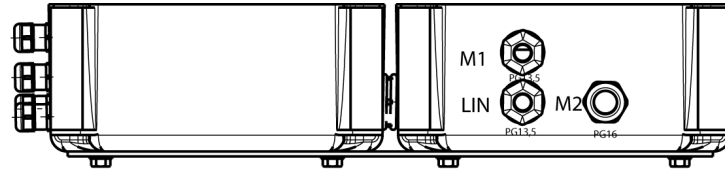


LISTA COMPONENTI

RIFERIMENTO	DESCRIZIONE	DATI TECNICI	SIGLA CATALOGO	QUANTITA	RIFERIMENTO DOCUMENTO
F1	PORTAFUSIBILE	3 POLI SEZIONABILE 10,3x38 32A 690V	515025	1	6.6
	FUSIBILE	10,3x38 16A 500V aM RITARDATO	507045	3	
F2	INTERRUTTORE AUTOM. TRIPOLARE	6,3-10A AC3 400V 2,2KW	518277	1	6.2
	CONTATTI AUSILIARI	1NO+1NC ATTACCO FRONTALE	518279	1	6.2
F3	PORTAFUSIBILE	2 POLI SEZIONABILE 10,3x38 32A 690V	515027	1	5.3
	FUSIBILE	10,3X38 2A 500V RAPIDO	507019	2	
F4	FUSIBILE	5x20F 250V 2A RAPIDO	507043	1	5.3
F5	FUSIBILE	5x20F 250V 8A RAPIDO	507090	1	5.3
F6	FUSIBILE	5X20 T 8A 250V	507118	1	5.7
K1	CONTATTORE TRIPOLARE	9A AC3 400V 4,2KW 1NC 24Vac 50/60Hz	522137	1	7.6
K2	CONTATTORE TRIPOLARE	9A AC3 400V 4,2KW 1NC 24Vac 50/60Hz	522137	1	7.6
K3	CONTATTORE TRIPOLARE	9A AC3 400V 4,2KW 1NC 24Vac 50/60Hz	522137	1	7.5
K4	CONTATTORE TRIPOLARE	9A AC3 400V 4,2KW 1NC 24Vac 50/60Hz	522137	1	7.5
	CONTATTI AUSILIARI	1NO+1NC ATTACCO FRONTALE	522147	1	7.4
K5	CONTATTORE	9A AC3 400V 4,2KW 1NC 24Vac 50/60Hz	522137	1	7.4
Q1...Q13	ELETTRIVALVOLE	-	-	13	8-9
Q14	SEZIONATORE TRIPOLARE	1th 32A Ui 690V-50Hz Uimp 4KW	518223+518226	1	5.2
Q15	COMMUTATORE DI POLI DAHLANDER	25A 500V	518189	1	6.5-6.6
MP3	MANIPOLATORE	MANIPOLATORE C 4 POS. TEMPORANEE	517285	1	14.2
MP2	MANIPOLATORE	MANIPOLATORE C 4 POS. TEMPORANEE	517285	1	14.2
MP1	MANIPOLATORE	MANIPOLATORE C 2 POS. TEMPORANEE	517286	-	-
SB1	PULSANTE	PULSANTE IP 55	4511000	1	14.4
SB2	PULSANTE	PULSANTE IP 55	4511000	1	14.7-14.8
SB3	PULSANTE	PULSANTE IP 55	4511000	1	14.5
T1	TRASFORMATORE	200 VA 50/60 Hz PRI: 0/230/400V SEC: 0/19V 8,95A 0/24V 1,25A	528056	1	5.3
M1	MOTORE CENTRALINA	1,85/2,5KW 400V 50HZ 4,9/7,7A cosØ=0,73/0,70 1400/2800 rpm	900003880	1	6.3
M2	MOTORE MANDRINO	1,35/1,85KW 400V 50Hz 1400/2800rpm	900003930	1	

COMPONENTS LIST

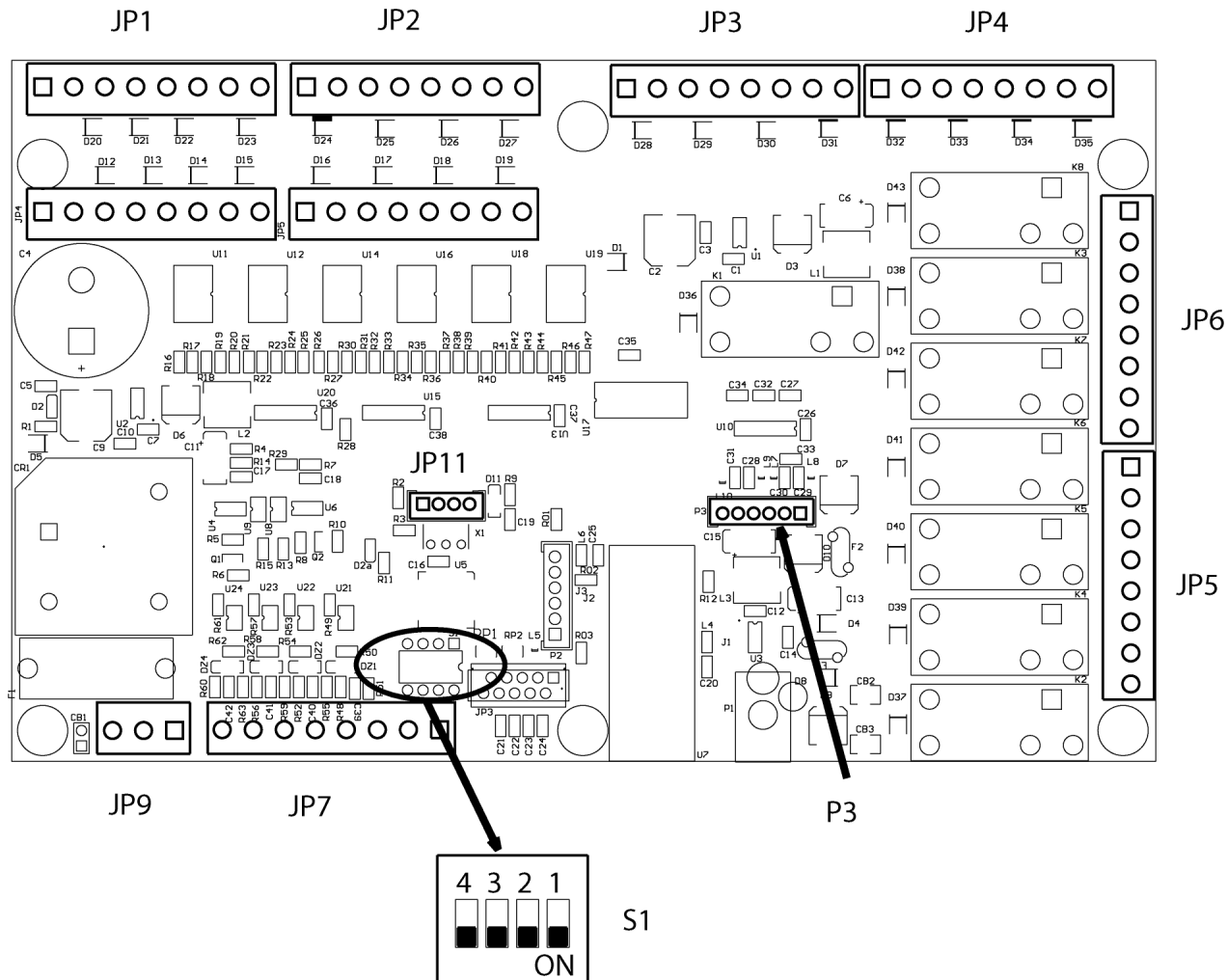
REFERENCE	DESCRIPTION	TECHNICAL SPECIFICATIONS	ABBREVIATION ON CATALOGUE	QUANTITY	DOCUMENT REFERENCE
F1	FUSE HOLDER	10,3x38 32A 690V SECTIONABLE 3 POLES	515025	1	6.6
	FUSE	10,3x38 16A 500V aM DELAYED-ACTION	507045	3	
F2	TRIPOLAR AUTOMATIC SWITCH	6,3-10A AC3 400V 2,2KW	518277	1	6.2
	AUXILIARY CONTACTS	1NO+1NC FRONT COUPLING	518279	1	6.2
F3	FUSE HOLDER	10,3x38 32A 690V 2 POLES SECTIONABLE	515027	1	5.3
	FUSE	10,3x38 2A 500V RAPID	507019	2	
F4	FUSE	5x20F 250V 2A RAPID	507043	1	5.3
F5	FUSE	5x20F 250V 8A RAPID	507090	1	5.3
F6	FUSE	5X20 T 8A 250V	507118	1	5.7
K1	TRIPOLAR CONTACTOR	9A AC3 400V 4,2KW 1NC 24Vac 50/60Hz	522137	1	7.6
K2	TRIPOLAR CONTACTOR	9A AC3 400V 4,2KW 1NC 24Vac 50/60Hz	522137	1	7.6
K3	TRIPOLAR CONTACTOR	9A AC3 400V 4,2KW 1NC 24Vac 50/60Hz	522137	1	7.5
K4	TRIPOLAR CONTACTOR	9A AC3 400V 4,2KW 1NC 24Vac 50/60Hz	522137	1	7.5
	AUXILIARY CONTACTS	1NO+1NC FRONT COUPLING	522147	1	7.4
K5	CONTACTOR	9A AC3 400V 4,2KW 1NC 24Vac 50/60Hz	522137	1	7.4
Q1...Q13	SOLENOID VALVES	-	-	13	8-9
Q14	TRIPOLAR KNIFE SWITCH	Ith 32A Ui 690V-50Hz Uimp 4KW	518223+518226	1	5.2
Q15	DAHLANDER POLES COMMUTATOR	25A 500V	518189	1	6.5-6.6
MP3	HANDLE CONTROL	HANDLE CONTROL C4 POS. TEMPORARY	517285	1	14.2
MP2	HANDLE CONTROL	HANDLE CONTROL C4 POS. TEMPORARY	517285	1	14.2
MP1	HANDLE CONTROL	HANDLE CONTROL C2 POS. TEMPORARY	517286	-	-
SB1	PUSHBUTTON	IP55 PUSHBUTTON	4511000	1	14.4
SB2	PUSHBUTTON	IP55 PUSHBUTTON	4511000	1	14.7-14.8
SB3	PUSHBUTTON	IP55 PUSHBUTTON	4511000	1	14.5
T1	TRANSFORMER	200 VA 50/60 Hz PRI: 0/230/400V SEC: 0/19V 8,95A 0/24V 1,25A	528056	1	5.3
M1	HYDRAULIC POWER UNIT MOTOR	1,85/2,5KW 400V 50HZ 4,9/7,7A cos θ =0,73/0,70 1400/2800 rpm	900003880	1	6.3
M2	MANDREL MOTOR	1,35/1,85KW 400V 50Hz 1400/2800rpm	900003930	1	



Tarare il salvamotore a 8A
Set the overload cut-out at 8A

TOPOGRAFICO SCHEDA RICEVENTE 18962

RECEIVING CARD 18962 TOPOGRAPHIC VIEW



IN/OUT SCHEDA RICEVENTE 18962

PIN JP1	NUMERO	FUNZIONE
1	JP1-1	Q1 INDIETRO CARRO UTENSILE
2	JP1-2	0V per Q1
3	JP1-3	Q2 AVANTI CARRO UTENSILE
4	JP1-4	0V per Q2
5	JP1-5	Q3 AVANTI CARRO MANDRINO
6	JP1-6	0V per Q3
7	JP1-7	Q4 INDIETRO CARRO MANDRINO
8	JP1-8	0V per Q4

PIN JP2	NUMERO	FUNZIONE
1	JP2-1	Q5 CHIUSURA MANDRINO
2	JP2-2	0V per Q5
3	JP2-3	Q6 APERTURA MANDRINO
4	JP2-4	0V per Q6
5	JP2-5	Q7 DISCESA BRACCIO MANDRINO
6	JP2-6	0V per Q7
7	JP2-7	Q8 SALITA BRACCIO MANDRINO
8	JP2-8	0V per Q8

PIN JP3	NUMERO	FUNZIONE
5	JP3-5	Q11 DISCESA BRACCIO UTENSILE
6	JP3-6	0V per Q11
7	JP3-7	Q12 SALITA BRACCIO UTENSILE
8	JP3-8	0V pe Q12

PIN JP4	NUMERO	FUNZIONE
1	JP4-1	Q13 RICIRCOLO OLIO
2	JP4-2	0V per Q13
3	JP4-3	N.U.
4	JP4-4	N.U.
5	JP4-5	N.U.
6	JP4-6	N.U.
7	JP4-7	N.U.
8	JP4-8	N.U.

PIN JP5	NUMERO	FUNZIONE
1	JP5-1	N.U.
2	JP5-2	N.U.
3	JP5-3	0 Vac
4	JP5-4	KM5 COMANDO ROTAZ. 2V CENTRALINA OLEOD
5	JP5-5	KM4 COMANDO MOTORE CENTRALINA A STELLA 2V
6	JP5-6	KM3 COMANDO ROTAZ. 1V CENTRALINA OLEOD
7	JP5-7	KM2 COMANDO ROTAZ. ORARIA MANDRINO
8	JP5-8	KM1 COMANDO ROTAZ. ANTIORARIA MANDRINO

PIN JP7	NUMERO	FUNZIONE
1	JP7-1	COLLEGATO A JP7-2
2	JP7-2	COLLEGATO A JP7-1
3	JP7-3	N.U.
4	JP7-4	N.U.
5	JP7-5	N.U.
6	JP7-6	N.U.
7	JP7-7	N.U.
8	JP7-8	N.U.

PIN JP9	NUMERO	FUNZIONE
1	JP9-1	0 Vac
2	JP9-2	N.U.
3	JP9-3	19 Vac



RAVAGLIOLI S.p.A.

**LISTA DEI COMPONENTI - LIST OF COMPONENTS - TEILELISTE
LISTE DES PIÈCES DÉTACHÉES - LISTA DE PIEZAS**

Tavola N°I - Rev. 0

752205601

SCHEMA ELETTRICO 3/17
ELECTRICAL SCHEME 3/17
SCHALTPLAN 3/17

SCHEMA ELECTRIQUE 3/17
ESQUEMA ELECTRICO 3/17

(G9256.15-G9256T.15-G10360.15-G10360T.15)(VARGNAVETH)

Pag. 123 di 168

G9256.11SL - G9256.11ST - G9256.15 - G9256T.15
G9256A.15 - G9256D.15 - G9256TD.15 - G9256.15SL
G10360.15 - G10360T.15 - G10360A.15
G10360D.15 - G10360TD.15

7522-M001-14_R

RECEIVING CARD 18962 IN/OUT

PIN JP1	NUMBER	FUNCTION
1	JP1 - 1	Q1 TOOL CARRIAGE BACKWARD
2	JP1 - 2	OV for Q1
3	JP1 - 3	Q2 TOOL CARRIAGE FORWARD
4	JP1 - 4	OV for Q2
5	JP1 - 5	Q3 MANDREL CARRIAGE FORWARD
6	JP1 - 6	OV for Q3
7	JP1 - 7	Q4 MANDREL CARRIAGE BACKWARD
8	JP1 - 8	OV for Q4

PIN JP2	NUMBER	FUNCTION
1	JP2 - 1	Q5 MANDREL CLOSING
2	JP2 - 2	OV for Q5
3	JP2 - 3	Q6 MANDREL OPENING
4	JP2 - 4	OV for Q6
5	JP2 - 5	Q7 MANDREL ARM DESCENT
6	JP2 - 6	OV for Q7
7	JP2 - 7	Q8 MANDREL ARM RISE
8	JP2 - 8	OV for Q8

PIN JP3	NUMBER	FUNCTION
5	JP3 - 5	Q11 TOOL ARM DESCENT
6	JP3 - 6	OV for Q11
7	JP3 - 7	Q12 TOOL ARM RISE
8	JP3 - 8	OV for Q12

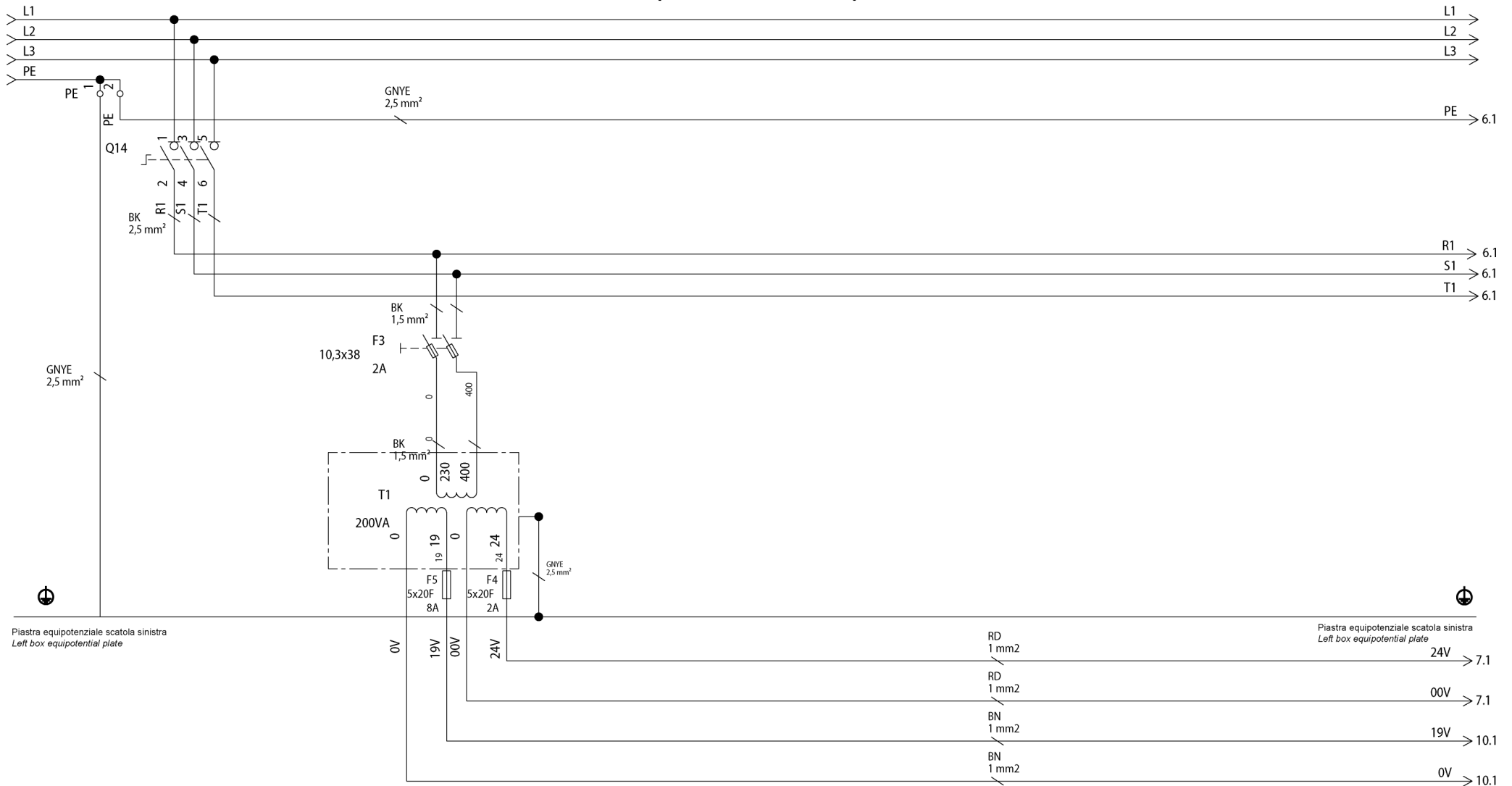
PIN JP4	NUMBER	FUNCTION
1	JP4 - 1	Q13 OIL RECIRCULATION
2	JP4 - 2	OV for Q13
3	JP4 - 3	N.U.
4	JP4 - 4	N.U.
5	JP4 - 5	N.U.
6	JP4 - 6	N.U.
7	JP4 - 7	N.U.
8	JP4 - 8	N.U.

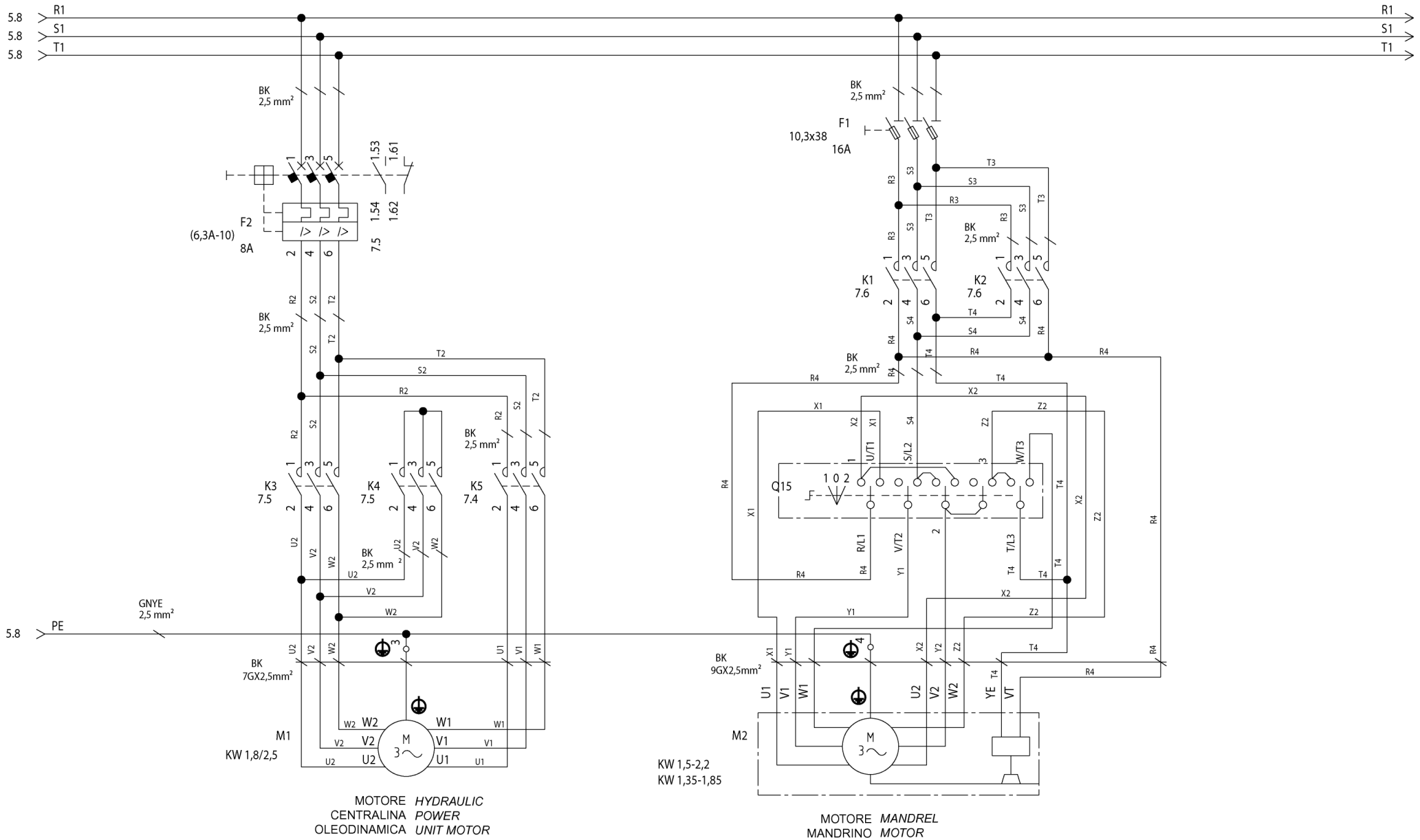
PIN JP5	NUMBER	FUNCTION
1	JP5 - 1	N.U.
2	JP5 - 2	N.U.
3	JP5 - 3	0 Vac
4	JP5 - 4	KM5 2V HYDR. POWER UNIT ROTATION CONTROL
5	JP5 - 5	KM4 2V STAR TYPE HYDR. POWER UNIT MOTOR ROT. CONTR.
6	JP5 - 6	KM3 1V HYDRAULIC POWER UNIT ROT. CONTROL
7	JP5 - 7	KM2 MANDREL CLOCKWISE ROTATION CONTROL
8	JP5 - 8	KM1 MANDREL COUNTERCLOCKWISE ROT. CONTROL

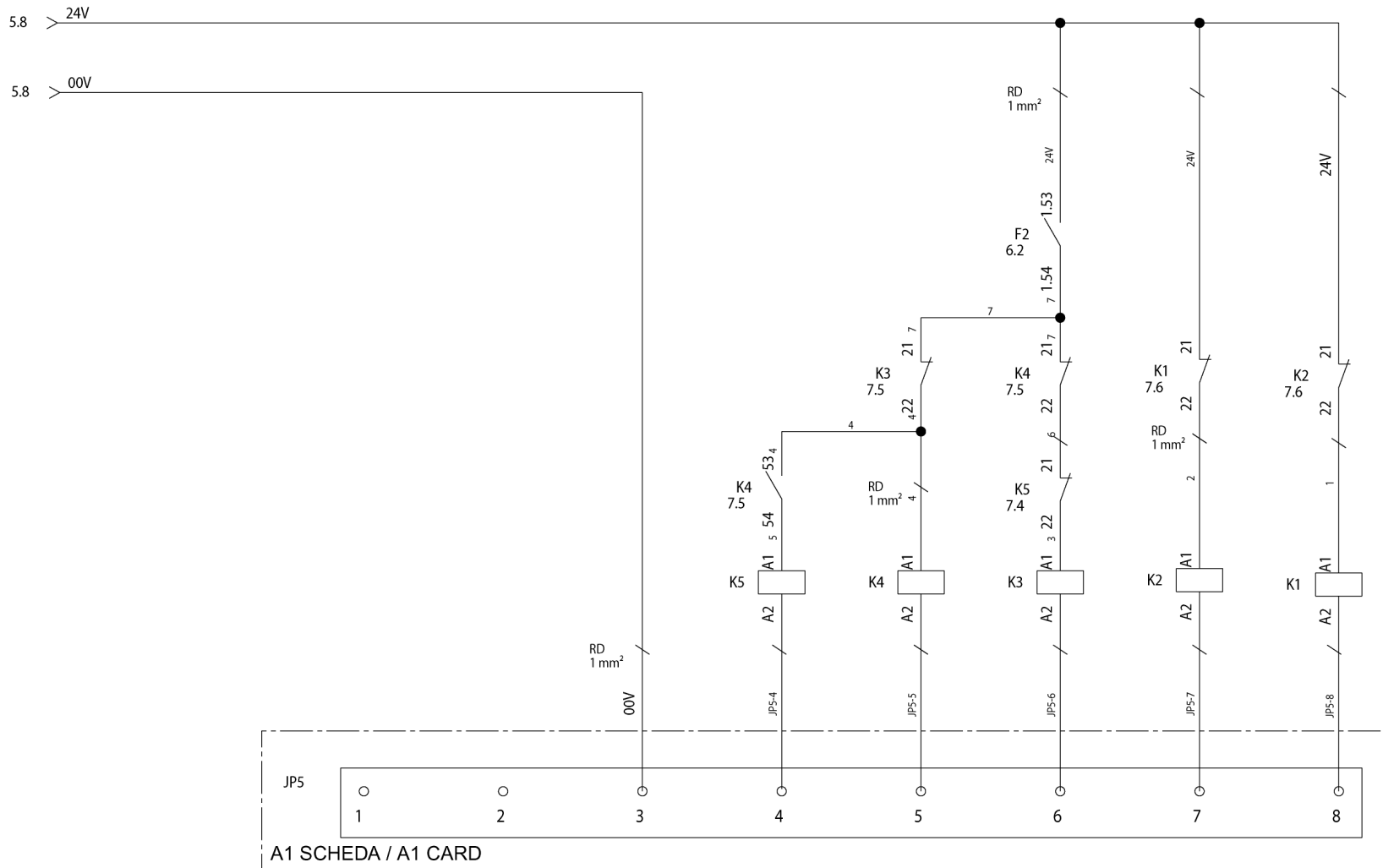
PIN JP7	NUMBER	FUNCTION
1	JP7 - 1	CONNECTED TO JP7-2
2	JP7 - 2	CONNECTED TO JP7-1
3	JP7 - 3	N.U.
4	JP7 - 4	N.U.
5	JP7 - 5	N.U.
6	JP7 - 6	N.U.
7	JP7 - 7	N.U.
8	JP7 - 8	N.U.

PIN JP9	NUMBER	FUNCTION
1	JP9 - 1	0 Vac
2	JP9 - 2	N.U.
3	JP9 - 3	19 Vac

SCHEMA CIRCUITI QUADRO ELETTRICO (RICEVITORE) ELECTRICAL PANEL (RECEIVER) CIRCUITS DIAGRAM







A1 SCHEDA / A1 CARD

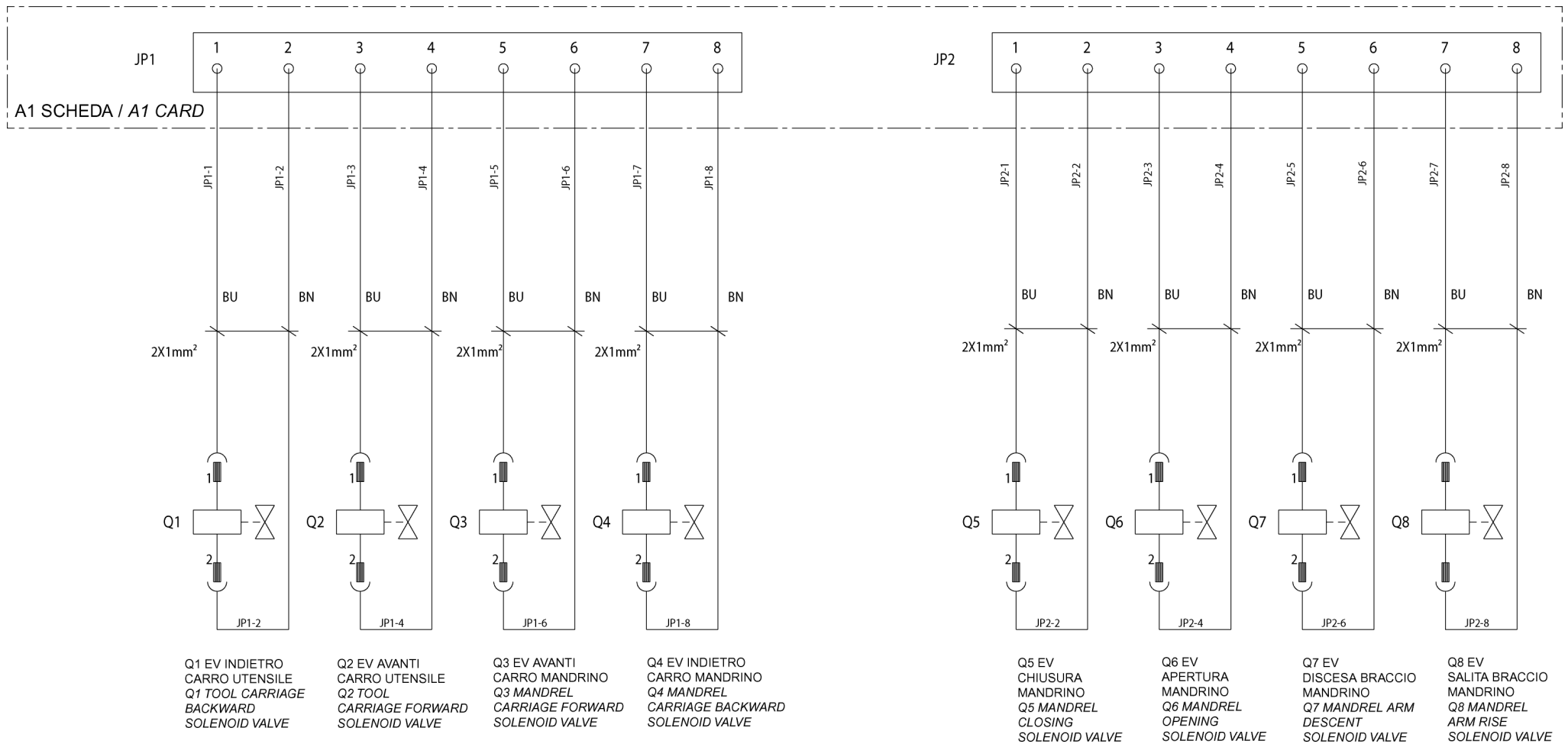
COMANDO
ROTAZIONE
2V CENTRALINA
OLEODINAMICA
2V HYDRAULIC
POWER UNIT
ROTATION
CONTROL

COMANDO
MOTORE
CENTRALINA
A STELLA 2V
2V STAR TYPE
HYDRAULIC
POWER UNIT
MOTOR ROTATION
CONTROL

COMANDO
ROTAZIONE
1V CENTRALINA
OLEODINAMICA
1V HYDRAULIC
POWER UNIT
ROTATION
CONTROL

COMANDO
ROTAZIONE
ORARIA
MANDRINO
CLOCKWISE
ROTATION
CONTROL

COMANDO
ROTAZIONE
ANTIORARIA
MANDRINO
COUNTERCLOCKWISE
ROTATION
CONTROL



RAVAGLIOLI S.p.A.

**LISTA DEI COMPONENTI - LIST OF COMPONENTS - TEILELISTE
LISTE DES PIÈCES DÉTACHÉES - LISTA DE PIEZAS**

Tavola N°I - Rev. 0

752205601

SCHEMA ELETTRICO 8/17
ELECTRICAL SCHEME 8/17
SCHALTPLAN 8/17

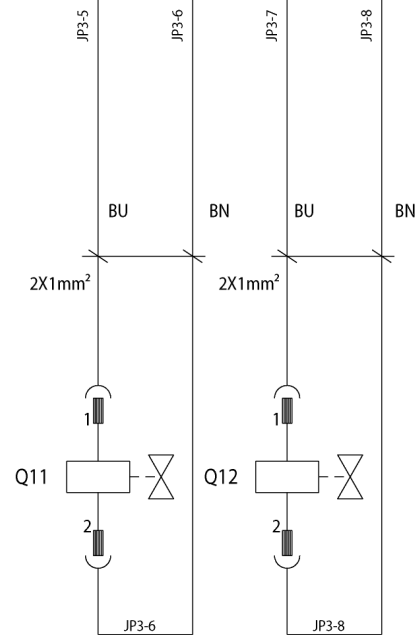
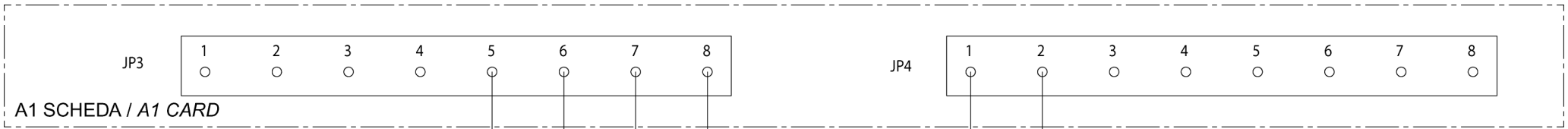
SCHEMA ELECTRIQUE 8/17
ESQUEMA ELECTRICO 8/17

(G9256.15-G9256T.15-G10360.15-G10360T.15)(VARGNAVETHI)

Pag. 128 di 168

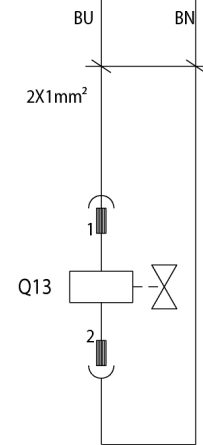
G9256.11SL - G9256.11ST - G9256.15 - G9256T.15
G9256A.15 - G9256D.15 - G9256TD.15 - G9256.15SL
G10360.15 - G10360T.15 - G10360A.15
G10360D.15 - G10360TD.15

7522-M001-14_R

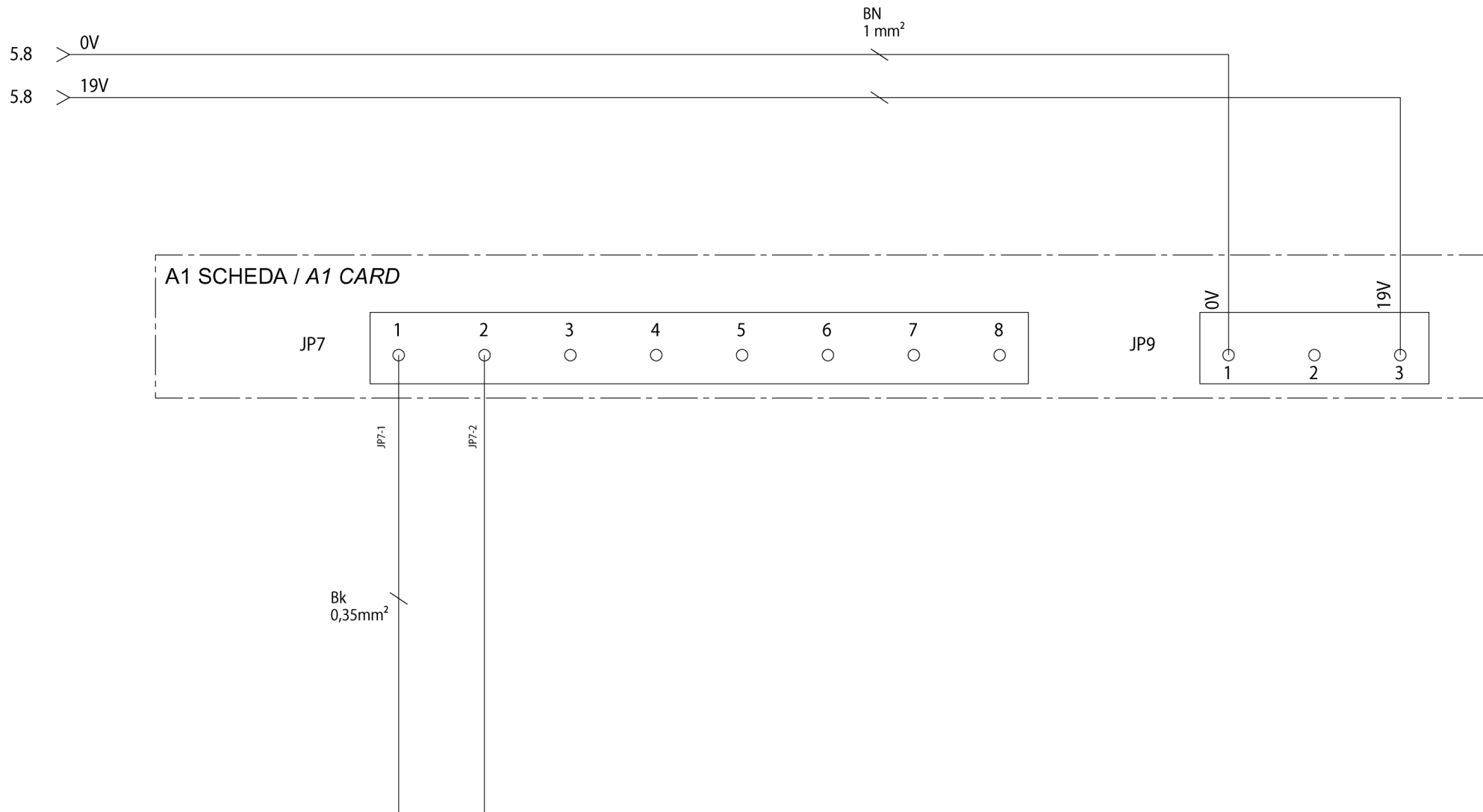


Q11 EV
DISCESA
BRACCIO
UTENSILE
Q11 TOOL
ARM DESCENT
SOLENOID
VALVE

Q12 EV
SALITA
BRACCIO
UTENSILE
Q12 TOOL
ARM RISE
SOLENOID
VALVE



Q13 EV
RICIRCOLO
OLIO
Q13 OIL
RECIRCULATION
SOLENOID VALVE



RAVAGLIOLI S.p.A.

**LISTA DEI COMPONENTI - LIST OF COMPONENTS - TEILELISTE
LISTE DES PIÈCES DÉTACHÉES - LISTA DE PIEZAS**

Tavola N°1 - Rev. 0

752205601

SCHEMA ELETTRICO 10/17
ELECTRICAL SCHEME 10/17
SCHALTPLAN 10/17

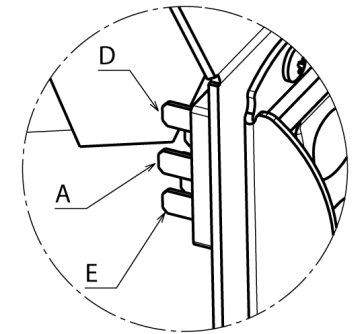
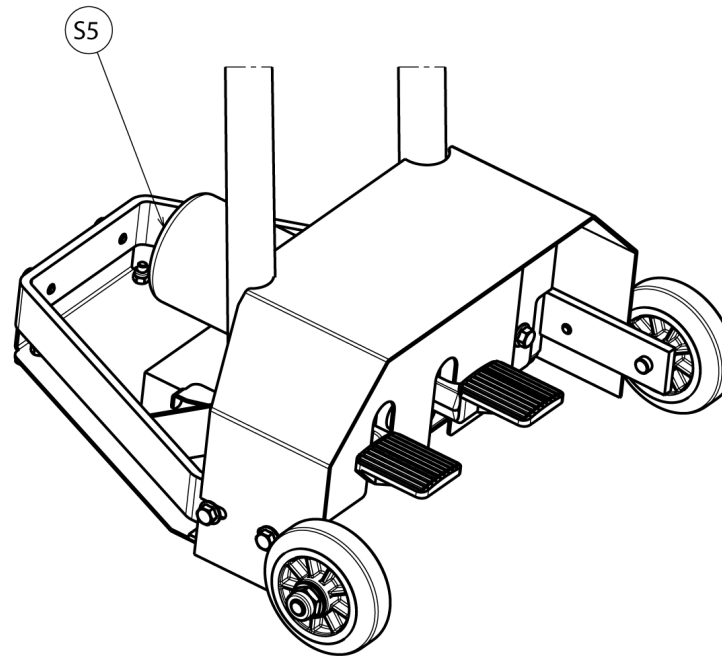
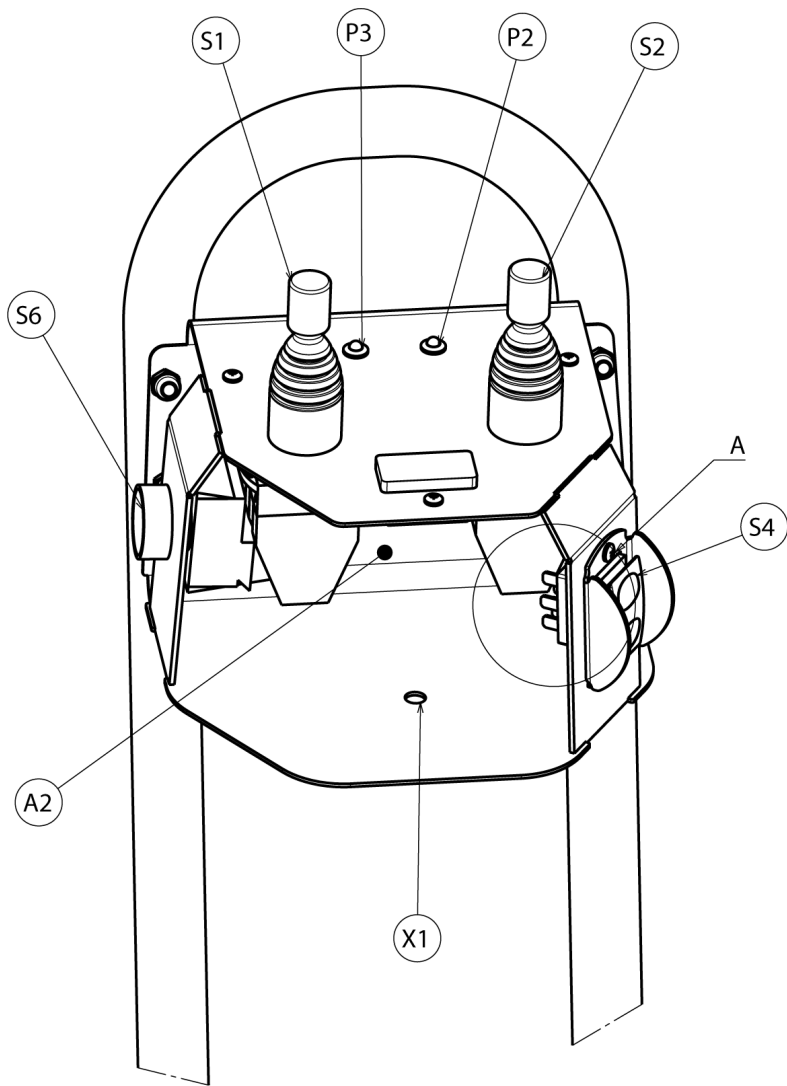
SCHEMA ELECTRIQUE 10/17
ESQUEMA ELECTRICO 10/17

(G9256.15-G9256T.15-G10360.15-G10360T.15)(VARGNAVETHI)

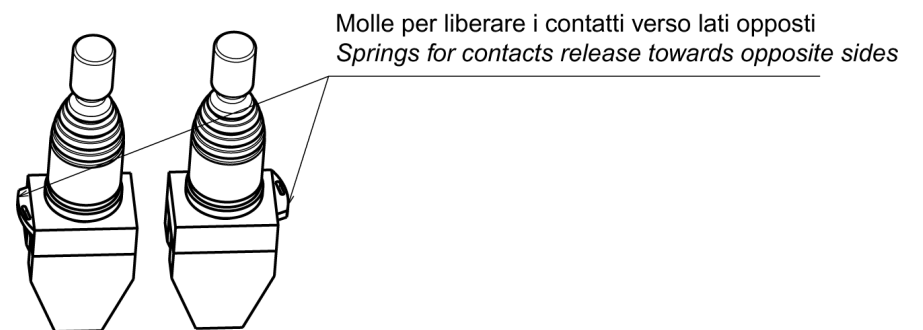
Pag. 130 di 168

G9256.11SL - G9256.11ST - G9256.15 - G9256T.15
G9256A.15 - G9256D.15 - G9256TD.15 - G9256.15SL
G10360.15 - G10360T.15 - G10360A.15
G10360D.15 - G10360TD.15

7522-M001-14_R



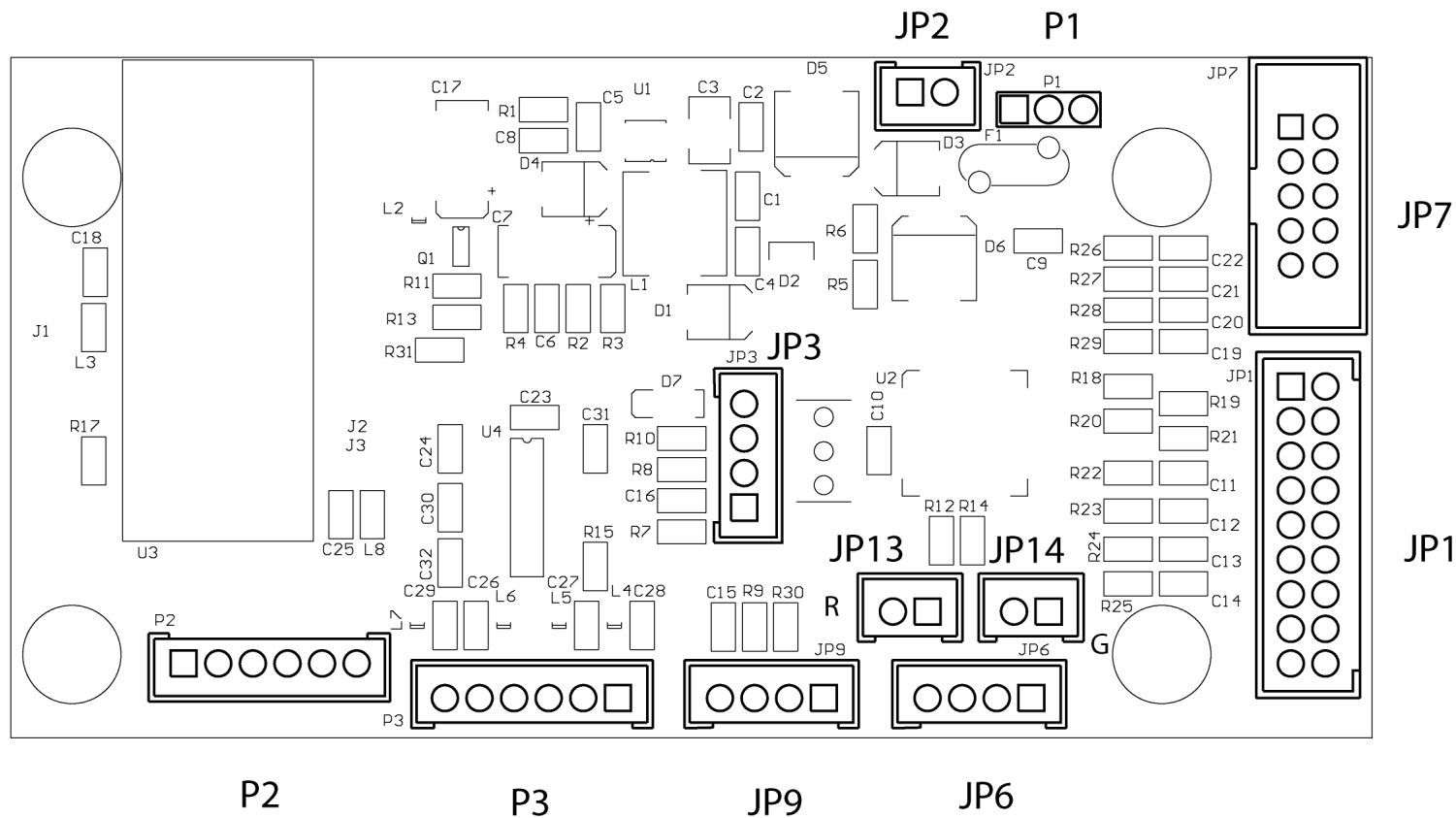
Dettaglio A
Detail A



 RAVAGLIOLI S.p.A.	LISTA DEI COMPONENTI - LIST OF COMPONENTS - TEILELISTE LISTE DES PIÈCES DÉTACHÉES - LISTA DE PIEZAS		SCHEMA ELETTRICO 11/17 ELECTRICAL SCHEME 11/17 SCHALTPLAN 11/17 SCHEMA ELECTRIQUE 11/17 ESQUEMA ELECTRICO 11/17 (G9256.15-G9256T.15-G10360.15-G10360T.15)(VARGNAVETH)	Pag. 131 di 168 <small>G9256.11SL - G9256.11ST - G9256.15 - G9256T.15 G9256A.15 - G9256D.15 - G9256TD.15 - G9256.15SL G10360.15 - G10360T.15 - G10360A.15 G10360D.15 - G10360TD.15</small>
	Tavola N°1 - Rev. 0	752205601		

TOPOGRAFICO SCHEDA TRASMITTENTE 18961

TRANSMITTING CARD 18961 TOPOGRAPHIC VIEW



 RAVAGLIOLI S.p.A.	LISTA DEI COMPONENTI - LIST OF COMPONENTS - TEILELISTE LISTE DES PIÈCES DÉTACHÉES - LISTA DE PIEZAS		SCHEMA ELETTRICO 12/17 ELECTRICAL SCHEME 12/17 SCHALTPLAN 12/17 SCHEMA ELECTRIQUE 12/17 ESQUEMA ELECTRICO 12/17 (G9256.15-G9256T.15-G10360.15-G10360T.15)(VARGNAVETH)	Pag. 132 di 168 G9256.11SL - G9256.11ST - G9256.15 - G9256T.15 G9256A.15 - G9256D.15 - G9256TD.15 - G9256.15SL G10360.15 - G10360T.15 - G10360A.15 G10360D.15 - G10360TD.15
	Tavola N°I - Rev. 0	752205601		

IN / OUT SCHEDA TRASMITTENTE 18961

TRANSMITTING CARD 18961 IN/OUT

PIN JP1	NUMERO	FUNZIONE
1	JP1-1	S1 INDIETRO CARRO MANDRINO
2	JP1-2	S2 INDIETRO CARRO UTENSILE
3	JP1-3	S1 AVANTI CARRO MANDRINO
4	JP1-4	S2 AVANTI CARRO UTENSILE
5	JP1-5	S1 SALITA BRACCIO MANDRINO
6	JP1-6	S2 DISCESA BRACCIO UTENSILE
7	JP1-7	S1 DISCESA BRACCIO MANDRINO
8	JP1-8	S2 SALITA BRACCIO UTENSILE
9	JP1-9	S1 (COMUNE)
10	JP1-10	S2 (COMUNE)
11	JP1-11	S4 (COMUNE)
12	JP1-12	N.U.
13	JP1-13	S4 PULSANTE CHIUSURA MANDRINO
14	JP1-14	N.U.
15	JP1-15	S4 PULSANTE APERTURA MANDRINO
16	JP1-16	N.U.
17	JP1-17	
18	JP1-18	N.U.

PIN JP1	NUMBER	FUNCTION
1	JP1-1	S1 MANDREL CARRIAGE BACKWARD
2	JP1-2	S2 TOOL CARRIAGE BACKWARD
3	JP1-3	S1 MANDREL CARRIAGE FORWARD
4	JP1-4	S2 TOOL CARRIAGE FORWARD
5	JP1-5	S1 MANDREL ARM RISE
6	JP1-6	S2 TOOL ARM DESCENT
7	JP1-7	S1 MANDREL ARM DESCENT
8	JP1-8	S2 TOOL ARM RISE
9	JP1-9	S1 (COMMON)
10	JP1-10	S2 (COMMON)
11	JP1-11	S4 (COMMON)
12	JP1-12	N.U.
13	JP1-13	S4 MANDREL CLOSING PUSHBUTTON
14	JP1-14	N.U.
15	JP1-15	S4 MANDREL OPENING PUSHBUTTON
16	JP1-16	N.U.
17	JP1-17	
18	JP1-18	N.U.

PIN JP6	NUMERO	FUNZIONE
1	JP6-1	S5 SELETT.ROTAZ.ANTIOR. MANDRINO
2	JP6-2	S5 SELETT. ROTAZ.ORARIA MANDRINO
3	JP6-3	
4	JP6-4	S5 COMUNE

PIN JP6	NUMBER	FUNCTION
1	JP6-1	S5 MANDREL COUNTERCLOCKWISE ROT. SELECTOR
2	JP6-2	S5 MANDREL CLOCKWISE ROT. SELECTOR
3	JP6-3	
4	JP6-4	S5 COMMON

PIN JP2	NUMERO	FUNZIONE
1	JP2-1	G2 BATTERIA -
2	JP2-2	G2 BATTERIA +

PIN JP2	NUMBER	FUNCTION
1	JP2-1	G2 BATTERY -
2	JP2-2	G2 BATTERY +

P1	NUMERO	FUNZIONE
X1		0-12Vdc

P1	NUMBER	FUNCTION
X1		0 - 12Vdc

PIN JP9	NUMERO	FUNZIONE
1	JP9-1	S6 PULS. DOPPIA VELOC. CENTR.
2	JP9-2	N.U.
3	JP9-3	S3 (COMUNE)
4	JP9-4	S6 PULS. DOPPIA VELOC. CENTR.

PIN JP9	NUMBER	FUNCTION
1	JP9-1	S6 HYDR. POWER UNIT DOUBLE SPEED PUSHBUTTON
2	JP9-2	N.U.
3	JP9-3	S3 (COMMON)
4	JP9-4	S6 HYDR. POWER UNIT DOUBLE SPEED PUSHBUTTON

PIN JP13	NUMERO	FUNZIONE
1	JP13-1	P2 LED ROSSO +
2	JP13-2	P2 LED ROSSO -

PIN JP13	NUMBER	FUNCTION
1	JP13-1	P2 RED LED +
2	JP13-2	P2 RED LED -

PIN JP14	NUMERO	FUNZIONE
1	JP14-1	P3 LED VERDE +
2	JP14-2	P3 LED VERDE -

PIN JP14	NUMBER	FUNCTION
1	JP14-1	P3 GREEN LED +
2	JP14-2	P3 GREEN LED -



RAVAGLIOLI S.p.A.

LISTA DEI COMPONENTI - LIST OF COMPONENTS - TEILELISTE
LISTE DES PIÈCES DÉTACHÉES - LISTA DE PIEZAS

Tavola N°I - Rev. 0

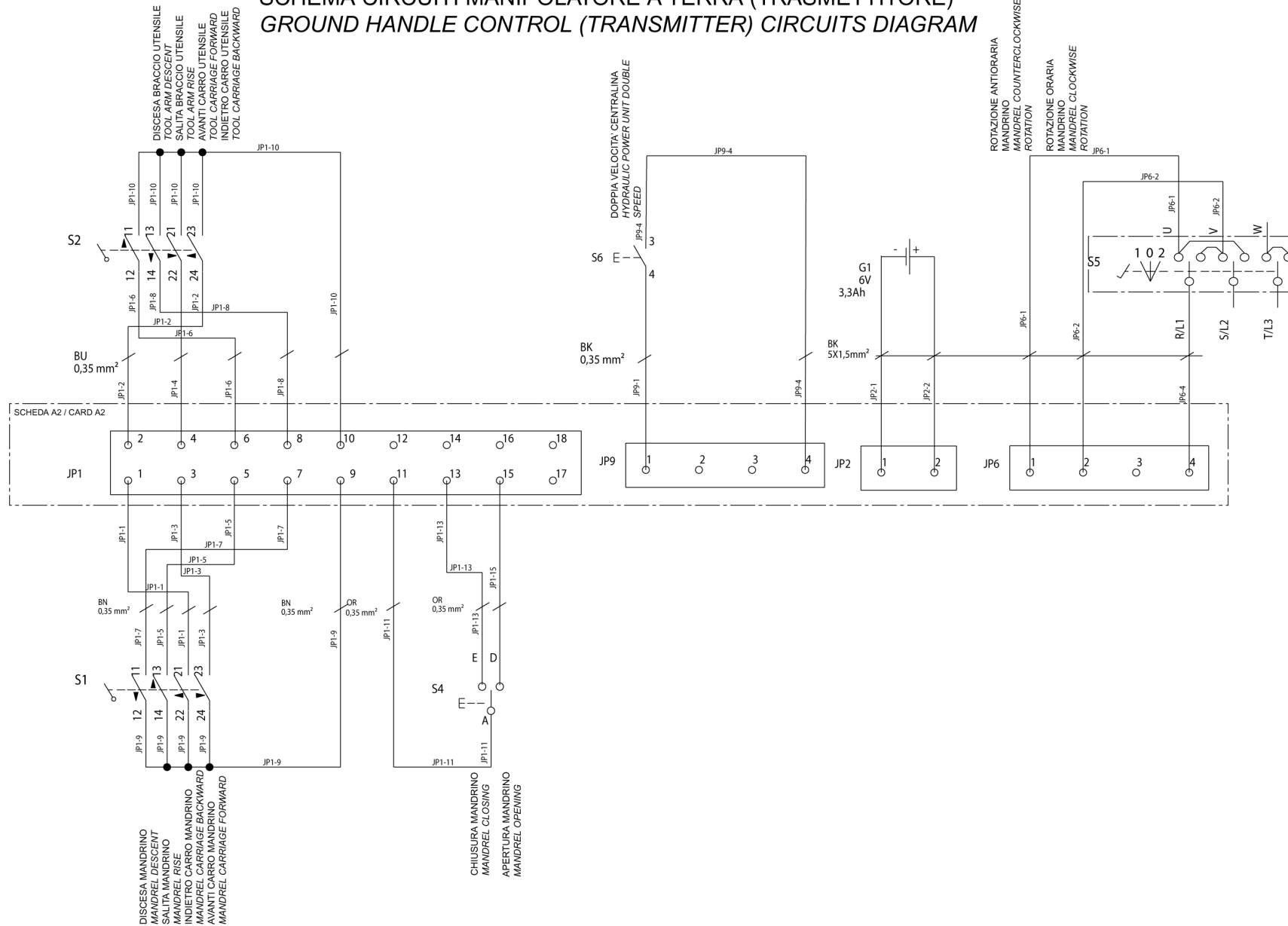
752205601

SCHEMA ELETTRICO 13/17
 ELECTRICAL SCHEME 13/17
 SCHALTPLAN 13/17
 SCHEMA ELECTRIQUE 13/17
 ESQUEMA ELECTRICO 13/17
 (G9256.15-G9256T.15-G10360.15-G10360T.15)(VARGNAVETHI)

Pag. 133 di 168

G9256.11SL - G9256.11ST - G9256.15 - G9256T.15
 G9256A.15 - G9256D.15 - G9256TD.15 - G9256.15SL
 G10360.15 - G10360T.15 - G10360A.15
 G10360D.15 - G10360TD.15

SCHEMA CIRCUITI MANIPOLATORE A TERRA (TRASMETTITORE)
GROUND HANDLE CONTROL (TRANSMITTER) CIRCUITS DIAGRAM



RAVAGLIOLI S.p.A.

LISTA DEI COMPONENTI - LIST OF COMPONENTS - TEILELISTE
LISTE DES PIECES DETACHEES - LISTA DE PIEZAS

Tavola N°I - Rev. 0

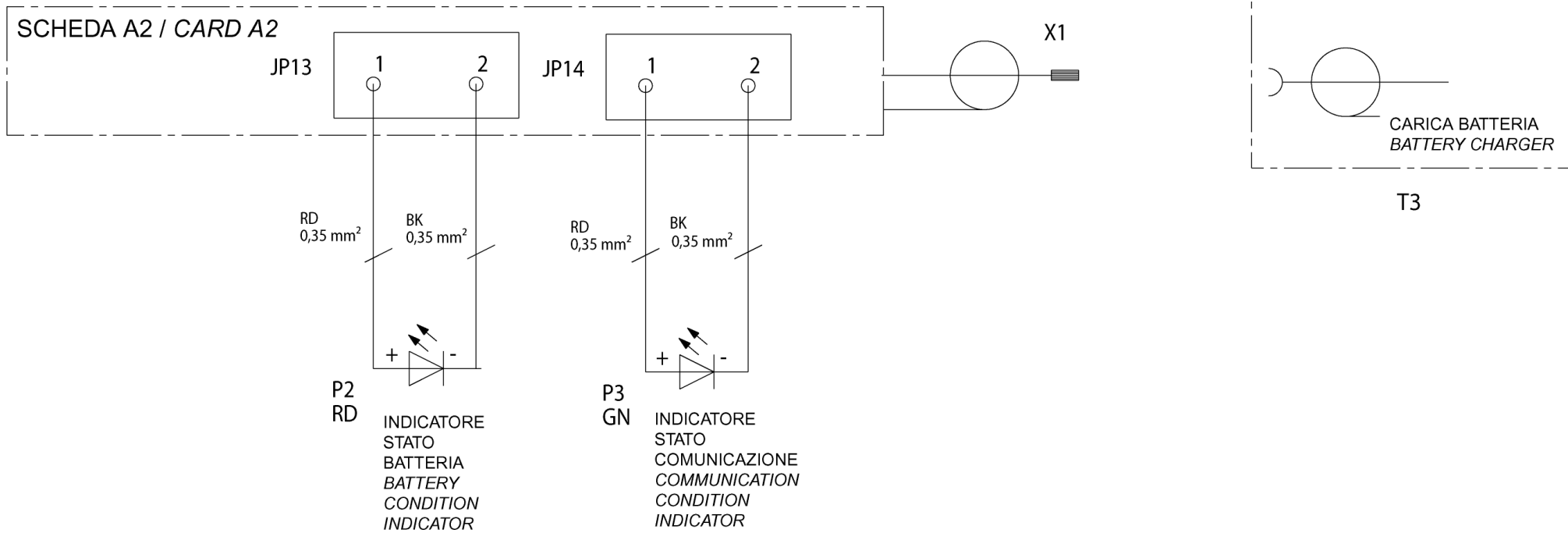
752205601

SCHEMA ELETTRICO 14/17
ELECTRICAL SCHEME 14/17
SCHALTPLAN 14/17
SCHEMA ELECTRIQUE 14/17
ESQUEMA ELECTRICO 14/17
(G9256.15-G9256T.15-G10360.15-G10360T.15)(VARGNAVETHI)

Pag. 134 di 168

G9256.11SL - G9256.11ST - G9256.15 - G9256T.15
G9256A.15 - G9256D.15 - G9256TD.15 - G9256.15SL
G10360.15 - G10360T.15 - G10360A.15
G10360D.15 - G10360TD.15

7522-M001-14_R

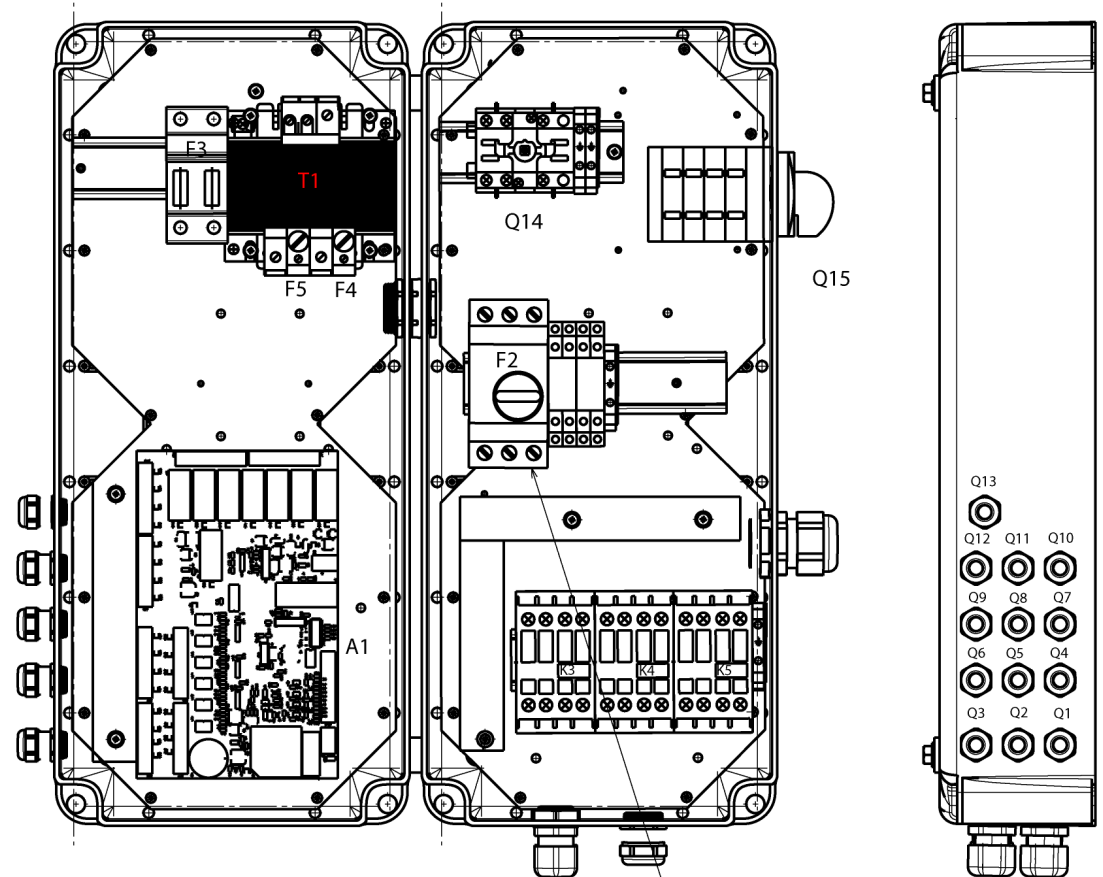
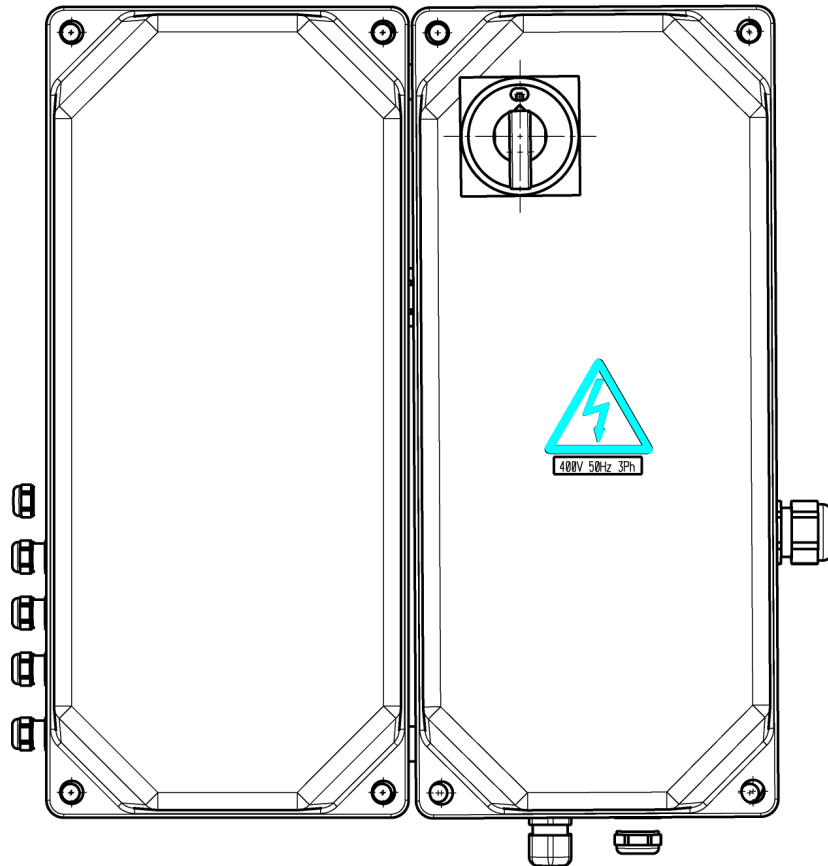
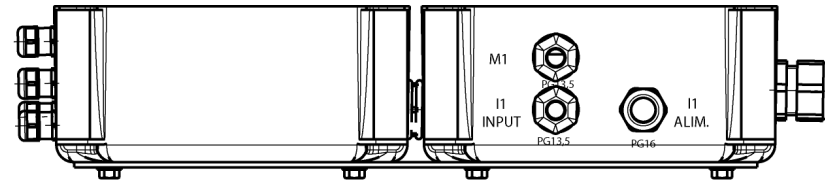


LISTA COMPONENTI

RIFERIMENTO	DESCRIZIONE	DATI TECNICI	SIGLA CATALOGO	QUANTITA	RIFERIMENTO DOCUMENTO
A1	SCHEDA ELETT. RICEVENTE	-	18962	1	2.5
A2	SCHEDA ELETT. TRASMITTENTE	-	18961	1	11.2
F1	PORTAFUSIBILE	3 POLI SEZIONABILE 10,3x38 32A 690V	515025	1	6.6
	FUSIBILE	10,3x38 16A 500V aM RITARDATO	507045	3	
F2	INTERRUTTORE AUTOM. TRIPOLARE	6,3-10A AC3 400V 2,2KW	518237	1	6.2
	CONTATTI AUSILIARI	1N0+1NC ATTACCO FRONTALE	518238	1	
F3	PORTAFUSIBILE	2 POLI SEZIONABILE 10,3x38 32A 690V	515027	1	5.3
	FUSIBILE	10,3X38 2A 500V RAPIDO	507019	2	
F4	FUSIBILE	5x20F 250V 2A RAPIDO	507043	1	5.3
F5	FUSIBILE	5x20F 250V 8A RAPIDO	507090	1	5.3
F6	FUSIBILE	5X20 T 8A 250V	507118	1	5.7
G1	BATTERIA	6V 3,3AH/20HR Lead	10066	1	14.6
K1	CONTATTORE TRIPOLARE	9A AC3 400V 4,2KW 1NC 24Vac 50/60Hz	522137	1	7.6
K2	CONTATTORE TRIPOLARE	9A AC3 400V 4,2KW 1NC 24Vac 50/60Hz	522137	1	7.6
K3	CONTATTORE TRIPOLARE	9A AC3 400V 4,2KW 1NC 24Vac 50/60Hz	522137	1	7.5
K4	CONTATTORE TRIPOLARE	9A AC3 400V 4,2KW 1NC 24Vac 50/60Hz	522137	1	7.5
	CONTATTI AUSILIARI	1N0+1NC ATTACCO FRONTALE	522147	1	
K5	CONTATTORE	9A AC3 400V 4,2KW 1NC 24Vac 50/60Hz	522137	1	7.4
P2	INDICATORE LUMINOSO (LED)	ROSSO	18065	1	15.4
P3	INDICATORE LUMINOSO (LED)	VERDE	18066	1	15.5
Q1...Q13	ELETTROVALVOLE	-	-	13	8-9
Q14	SEZIONATORE TRIPOLARE	Ith 32A Ui 690V-50Hz Uimp 4KW	518223+518226	1	5.2
Q15	COMMUTATORE DI POLI DAHLANDER	25A 500V	518189	1	6.5-6.6
S1	MANIPOLATORE	4 POS.+CENTR.TEMPORANEE Ø22	517157AS	1	14.2
S2	MANIPOLATORE	4 POS.+CENTR.TEMPORANEE Ø22	517157AS	1	14.2
-	-	-	-	-	-
S4	PULSANTE BASCULANTE	-	517283	1	14.4
S5	COMMUTATORE	Ith 25A Ui 690V-50Hz Uimp 4KW	518058	1	14.7-14.8
S6	PULSANTE	-	517105AS	1	14.5
T1	TRASFORMATORE	200 VA 50/60 Hz PRI: 0/230/400V SEC: 0/19V 8,95A 0/24V 1,25A	528056	1	5.3
T3	CARICABATTERIA	21.6W 7.2V 3A Lithium ion	18064	1	15.6
M1	MOTORE CENTRALINA	1,85/2,5KW 400V 50HZ 4,9/7,7A cosØ=0,73/0,70 1400/2800 rpm	900003880	1	6.3
M2	MOTORE MANDRINO	1,35/1,85KW 400V 50Hz 1400/2800rpm AUTOFR.	900003840		
M2	MOTORE MANDRINO	1,5/2,2KW 400V 50Hz 4,2/6A cosØ=0,80/0,84 1400/2800rpm AUTOFR.	900003810	1	6.5

COMPONENTS LIST

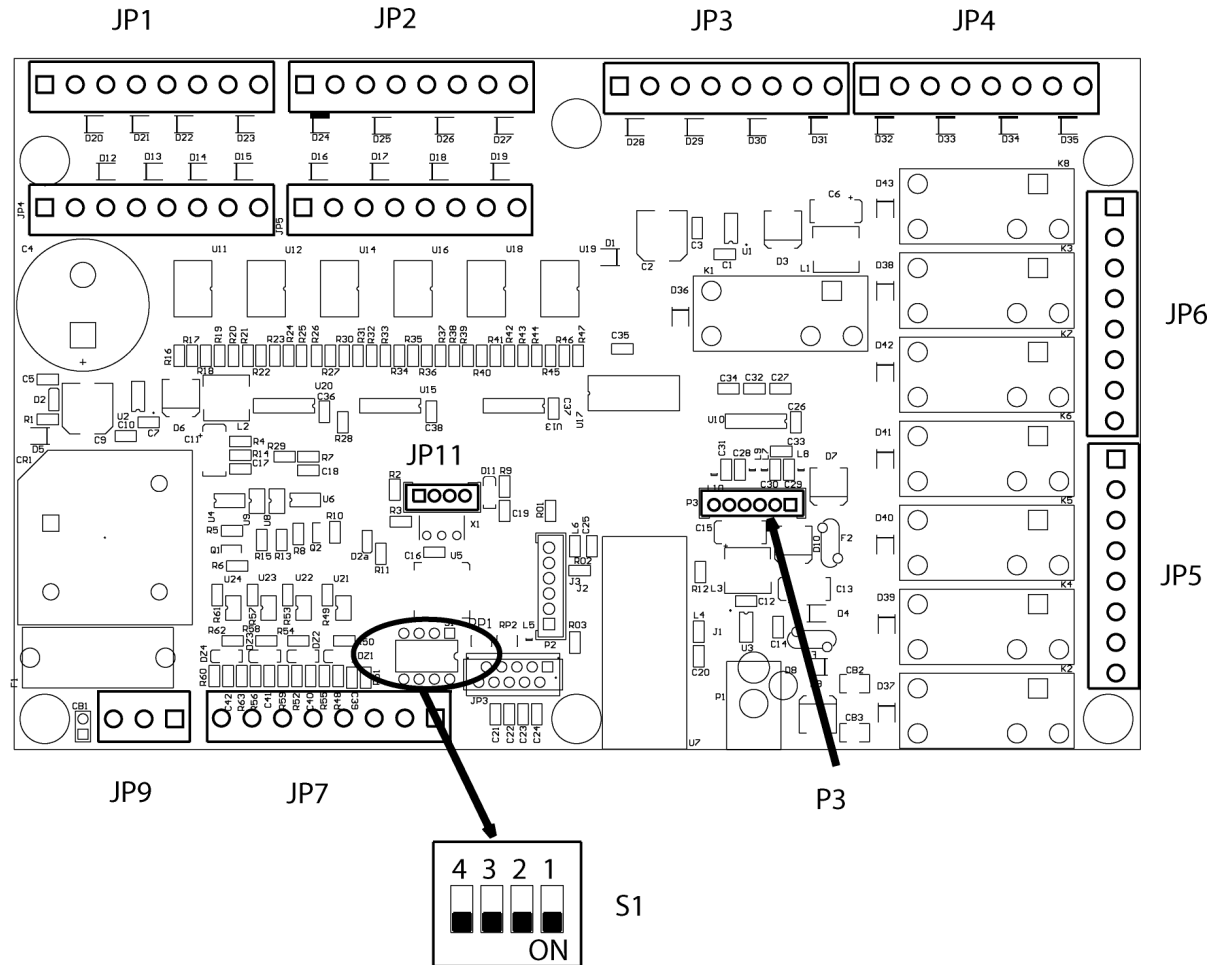
REFERENCE	DESCRIPTION	TECHNICAL SPECIFICATIONS	ABBREVIATION ON CATALOGUE	QUANTITY	DOCUMENT REFERENCE
A1	RECEIVING ELECTRICAL CARD	-	18962	1	2.5
A2	TRANSMITTING ELECTRICAL CARD	-	18961	1	11.2
F1	FUSE HOLDER	10,3x38 32A 690V SECTIONABLE 3 POLES	515025	1	6.6
	FUSE	10,3x38 16A 500V aM DELAYED-ACTION	507045	3	
F2	TRIPOLAR AUTOMATIC SWITCH	6,3-10A AC3 400V 2,2KW	518237	1	6.2
	AUXILIARY CONTACTS	1NO+1NC FRONT COUPLING	518238	1	6.2
F3	FUSE HOLDER	10,3x38 32A 690V 2 POLES SECTIONABLE	515027	1	5.3
	FUSE	10,3x38 2A 500V RAPID	507019	2	
F4	FUSE	5x20F 250V 2A RAPID	507043	1	5.3
F5	FUSE	5x20F 250V 8A RAPID	507090	1	5.3
F6	FUSE	5X20 T 8A 250V	507118	1	5.7
G1	BATTERY	6V 3,3AH/20HR Lead	10066	1	14.6
K1	TRIPOLAR CONTACTOR	9A AC3 400V 4,2KW 1NC 24Vac 50/60Hz	522137	1	7.6
K2	TRIPOLAR CONTACTOR	9A AC3 400V 4,2KW 1NC 24Vac 50/60Hz	522137	1	7.6
K3	TRIPOLAR CONTACTOR	9A AC3 400V 4,2KW 1NC 24Vac 50/60Hz	522137	1	7.5
K4	TRIPOLAR CONTACTOR	9A AC3 400V 4,2KW 1NC 24Vac 50/60Hz	522137	1	7.5
	AUXILIARY CONTACTS		522147	1	7.4
K5	CONTACTOR	9A AC3 400V 4,2KW 1NC 24Vac 50/60Hz	522137	1	7.4
P2	BACKLIGHTED INDICATOR (LED)	RED	18065	1	15.4
P3	BACKLIGHTED INDICATOR (LED)	GREEN	18066	1	15.5
Q1...Q13	SOLENOID VALVES	-	-	13	8-9
Q14	TRIPOLAR KNIFE SWITCH	Ith 32A Ui 690V-50Hz Uimp 4KW	518223+518226	1	5.2
Q15	DAHLANDER POLES COMMUTATOR	25A 500V	518189	1	6.5-6.6
S1	HANDLE CONTROL	4 POS.+ CENTRAL POS. TEMPORARY Ø22	517157AS	1	14.2
S2	HANDLE CONTROL	2 POS.+ CENTRAL POS. TEMPORARY Ø 22	517157AS	1	14.2
-	-	-	-	-	-
S4	BALANCING PUSHBUTTON	-	517283	1	14.4
S5	COMMUTATOR	Ith 25A Ui 690V-50Hz Uimp 4KW	518058	1	14.7-14.8
S6	PUSHBUTTON	-	517105AS	1	14.5
T1	TRANSFORMER	200 VA 50/60 Hz PRI: 0/230/400V SEC: 0/19V 8,95A 0/24V 1,25A	528056	1	5.3
T3	BATTERY CHARGER	21.6W 7.2V 3A Lithium ion	18064	1	15.6
M1	HYDRAULIC POWER UNIT MOTOR	1,85/2,5KW 400V 50Hz 4,9/7,7A cosØ=0,73/0,70 1400/2800 rpm	900003880	1	6.3
M2	MANDREL MOTOR	1,35/1,85KW 400V 50Hz 1400/2800rpm AUTOFR.	900003840		
M2	MANDREL MOTOR	1,5/2,2KW 400V 50Hz 4,2/6A cosØ=0,80/0,84 1400/2800rpm AUTOFR.	900003810	1	6.5



Tarare il salvamotore a 8A
Set the overload cut-out at 8A

TOPOGRAFICO SCHEDA RICEVENTE 18962

RECEIVING CARD 18962 TOPOGRAPHIC VIEW



 RAVAGLIOLI S.p.A.	LISTA DEI COMPONENTI - LIST OF COMPONENTS - TEILELISTE LISTE DES PIÈCES DÉTACHÉES - LISTA DE PIEZAS		SCHEMA ELETTRICO 2/18 - ELECTRICAL SCHEME 2/18 SCHALTPLAN 2/18 - SCHEMA ELECTRIQUE 2/18 ESQUEMA ELECTRICO 2/18 (G9256.11SL - G9256.15SL (VARGNAV43AD)) (G9256D.15 - G9256TD.15 - G10360D.15 - G10360TD.15 (VARGNAVDBTH))	Pag. 139 di 168 <small>G9256.11SL - G9256.11ST - G9256.15 - G9256T.15 G9256A.15 - G9256D.15 - G9256TD.15 - G9256.15SL G10360.15 - G10360T.15 - G10360A.15 G10360D.15 - G10360TD.15</small>
	Tavola N°L - Rev. 0	752205642		

IN/OUT SCHEDA RICEVENTE 18962

PIN JP1	NUMERO	FUNZIONE
1	JP1-1	Q1 INDIETRO CARRO UTENSILE
2	JP1-2	0V per Q1
3	JP1-3	Q2 AVANTI CARRO UTENSILE
4	JP1-4	0V per Q2
5	JP1-5	Q3 AVANTI CARRO MANDRINO
6	JP1-6	0V per Q3
7	JP1-7	Q4 INDIETRO CARRO MANDRINO
8	JP1-8	0V per Q4

PIN JP2	NUMERO	FUNZIONE
1	JP2-1	Q5 CHIUSURA MANDRINO
2	JP2-2	0V per Q5
3	JP2-3	Q6 APERTURA MANDRINO
4	JP2-4	0V per Q6
5	JP2-5	Q7 DISCESA BRACCIO MANDRINO
6	JP2-6	0V per Q7
7	JP2-7	Q8 SALITA BRACCIO MANDRINO
8	JP2-8	0V per Q8

PIN JP3	NUMERO	FUNZIONE
1	JP3-1	Q9 ROTAZ.ANTIORARIA UTENSILE
2	JP3-2	0V per Q9
3	JP3-3	Q10 ROTAZ.ORARIA UTENSILE
4	JP3-4	0V per Q10
5	JP3-5	Q11 DISCESA BRACCIO UTENSILE
6	JP3-6	0V per Q11
7	JP3-7	Q12 SALITA BRACCIO UTENSILE
8	JP3-8	0V pe Q12

PIN JP4	NUMERO	FUNZIONE
1	JP4-1	Q13 RICIRCOLO OLIO
2	JP4-2	0V per Q13
3	JP4-3	N.U.
4	JP4-4	N.U.
5	JP4-5	N.U.
6	JP4-6	N.U.
7	JP4-7	N.U.
8	JP4-8	N.U.

PIN JP5	NUMERO	FUNZIONE
1	JP5-1	N.U.
2	JP5-2	N.U.
3	JP5-3	0 Vac
4	JP5-4	KM5 COMANDO ROTAZ. 2V CENTRALINA OLEOD
5	JP5-5	KM4 COMANDO MOTORE CENTRALINA A STELLA 2V
6	JP5-6	KM3 COMANDO ROTAZ. 1V CENTRALINA OLEOD
7	JP5-7	KA1 COMANDO ROTAZ. ORARIA MANDRINO
8	JP5-8	KA2 COMANDO ROTAZ. ANTIORARIA MANDRINO

PIN JP7	NUMERO	FUNZIONE
1	JP7-1	COLLEGATO A JP7-2
2	JP7-2	COLLEGATO A JP7-1
3	JP7-3	N.U.
4	JP7-4	N.U.
5	JP7-5	N.U.
6	JP7-6	N.U.
7	JP7-7	N.U.
8	JP7-8	N.U.

PIN JP9	NUMERO	FUNZIONE
1	JP9-1	0 Vac
2	JP9-2	N.U.
3	JP9-3	19 Vac

RECEIVING CARD 18962 IN/OUT

PIN JP1	NUMBER	FUNCTION
1	JP1 - 1	Q1 TOOL CARRIAGE BACKWARD
2	JP1 - 2	OV for Q1
3	JP1 - 3	Q2 TOOL CARRIAGE FORWARD
4	JP1 - 4	OV for Q2
5	JP1 - 5	Q3 MANDREL CARRIAGE FORWARD
6	JP1 - 6	OV for Q3
7	JP1 - 7	Q4 MANDREL CARRIAGE BACKWARD
8	JP1 - 8	OV for Q4

PIN JP2	NUMBER	FUNCTION
1	JP2 - 1	Q5 MANDREL CLOSING
2	JP2 - 2	OV for Q5
3	JP2 - 3	Q6 MANDREL OPENING
4	JP2 - 4	OV for Q6
5	JP2 - 5	Q7 MANDREL ARM DESCENT
6	JP2 - 6	OV for Q7
7	JP2 - 7	Q8 MANDREL ARM RISE
8	JP2 - 8	OV for Q8

PIN JP3	NUMBER	FUNCTION
1	JP3 - 1	Q9 TOOL COUNTERCLOCKWISE ROT.
2	JP3 - 2	OV for Q9
3	JP3 - 3	Q10 TOOL CLOCKWISE ROTATION
4	JP3 - 4	OV for Q10
5	JP3 - 5	Q11 TOOL ARM DESCENT
6	JP3 - 6	OV for Q11
7	JP3 - 7	Q12 TOOL ARM RISE
8	JP3 - 8	OV for Q12

PIN JP4	NUMBER	FUNCTION
1	JP4 - 1	Q13 OIL RECIRCULATION
2	JP4 - 2	OV for Q13
3	JP4 - 3	N.U.
4	JP4 - 4	N.U.
5	JP4 - 5	N.U.
6	JP4 - 6	N.U.
7	JP4 - 7	N.U.
8	JP4 - 8	N.U.

PIN JP5	NUMBER	FUNCTION
1	JP5 - 1	N.U.
2	JP5 - 2	N.U.
3	JP5 - 3	0 Vac
4	JP5 - 4	KM5 2V HYDR. POWER UNIT ROTATION CONTROL
5	JP5 - 5	KM4 2V STAR TYPE HYDR. POWER UNIT MOTOR ROT. CONTR.
6	JP5 - 6	KM3 1V HYDRAULIC POWER UNIT ROT. CONTROL
7	JP5 - 7	KA1 MANDREL CLOCKWISE ROTATION CONTROL
8	JP5 - 8	KA2 MANDREL COUNTERCLOCKWISE ROT. CONTROL

PIN JP7	NUMBER	FUNCTION
1	JP7 - 1	CONNECTED TO JP7-2
2	JP7 - 2	CONNECTED TO JP7-1
3	JP7 - 3	N.U.
4	JP7 - 4	N.U.
5	JP7 - 5	N.U.
6	JP7 - 6	N.U.
7	JP7 - 7	N.U.
8	JP7 - 8	N.U.

PIN JP9	NUMBER	FUNCTION
1	JP9 - 1	0 Vac
2	JP9 - 2	N.U.
3	JP9 - 3	19 Vac



RAVAGLIOLI S.p.A.

**LISTA DEI COMPONENTI - LIST OF COMPONENTS - TEILELISTE
LISTE DES PIÈCES DÉTACHÉES - LISTA DE PIEZAS**

Tavola N°L - Rev. 0

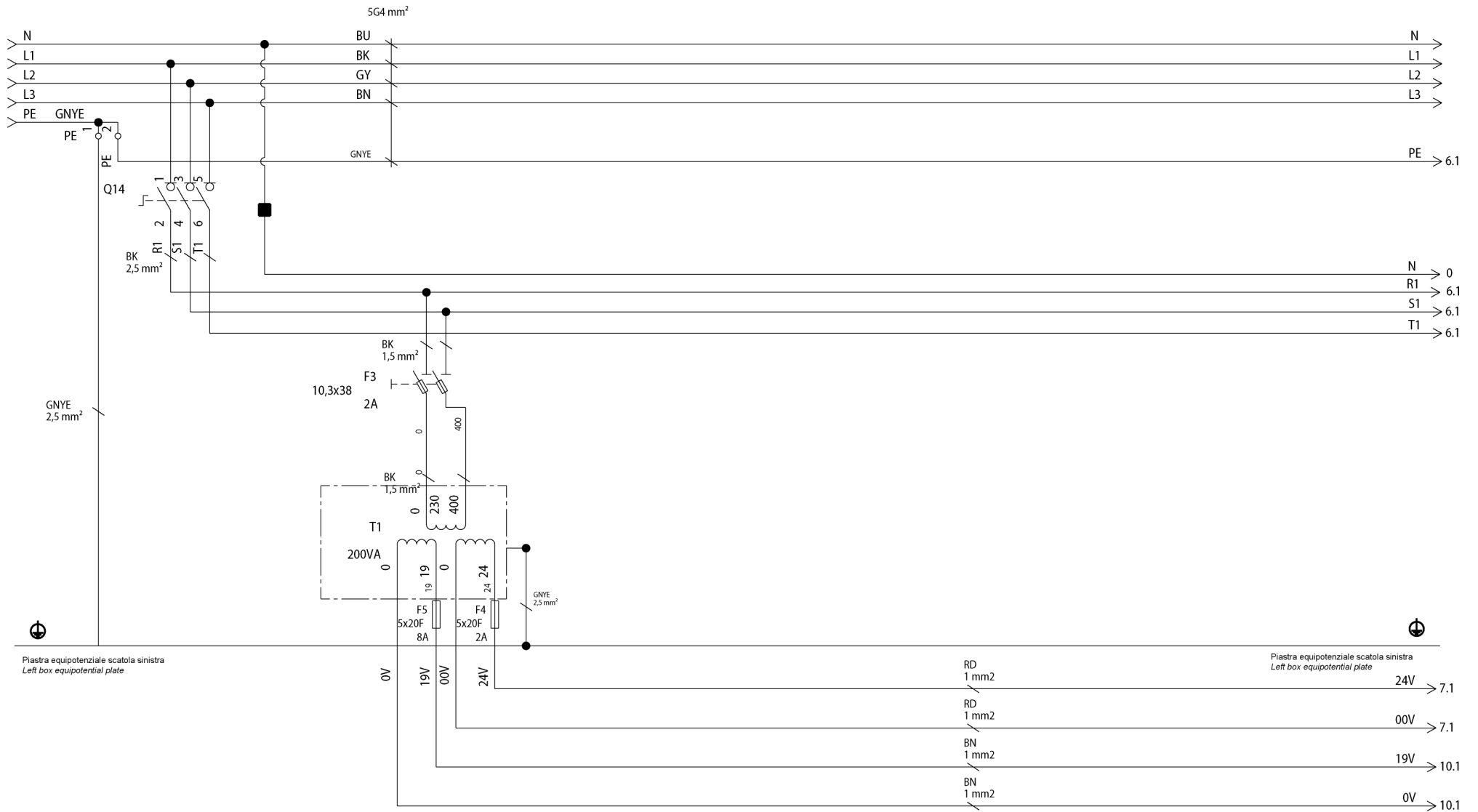
752205642

SCHEMA ELETTRICO 4/18 - ELECTRICAL SCHEME 4/18
SCHALTPLAN 4/18 - SCHEMA ELECTRIQUE 4/18
ESQUEMA ELECTRICO 4/18
(G9256.11SL - G9256.15SL (VARGNAV43AD))
(G9256D.15 - G9256TD.15 - G10360D.15 - G10360TD.15
(VARGNAVDBTH))

Pag. 141 di 168

G9256.11SL - G9256.11ST - G9256.15 - G9256T.15
G9256A.15 - G9256D.15 - G9256TD.15 - G9256.15SL
G10360.15 - G10360T.15 - G10360A.15
G10360D.15 - G10360TD.15

SCHEMA CIRCUITI QUADRO ELETTRICO (RICEVITORE) ELECTRICAL PANEL (RECEIVER) CIRCUITS DIAGRAM



RAVAGLIOLI S.p.A.

**LISTA DEI COMPONENTI - LIST OF COMPONENTS - TEILELISTE
LISTE DES PIÈCES DÉTACHÉES - LISTA DE PIEZAS**

Tavola N°L - Rev. 0

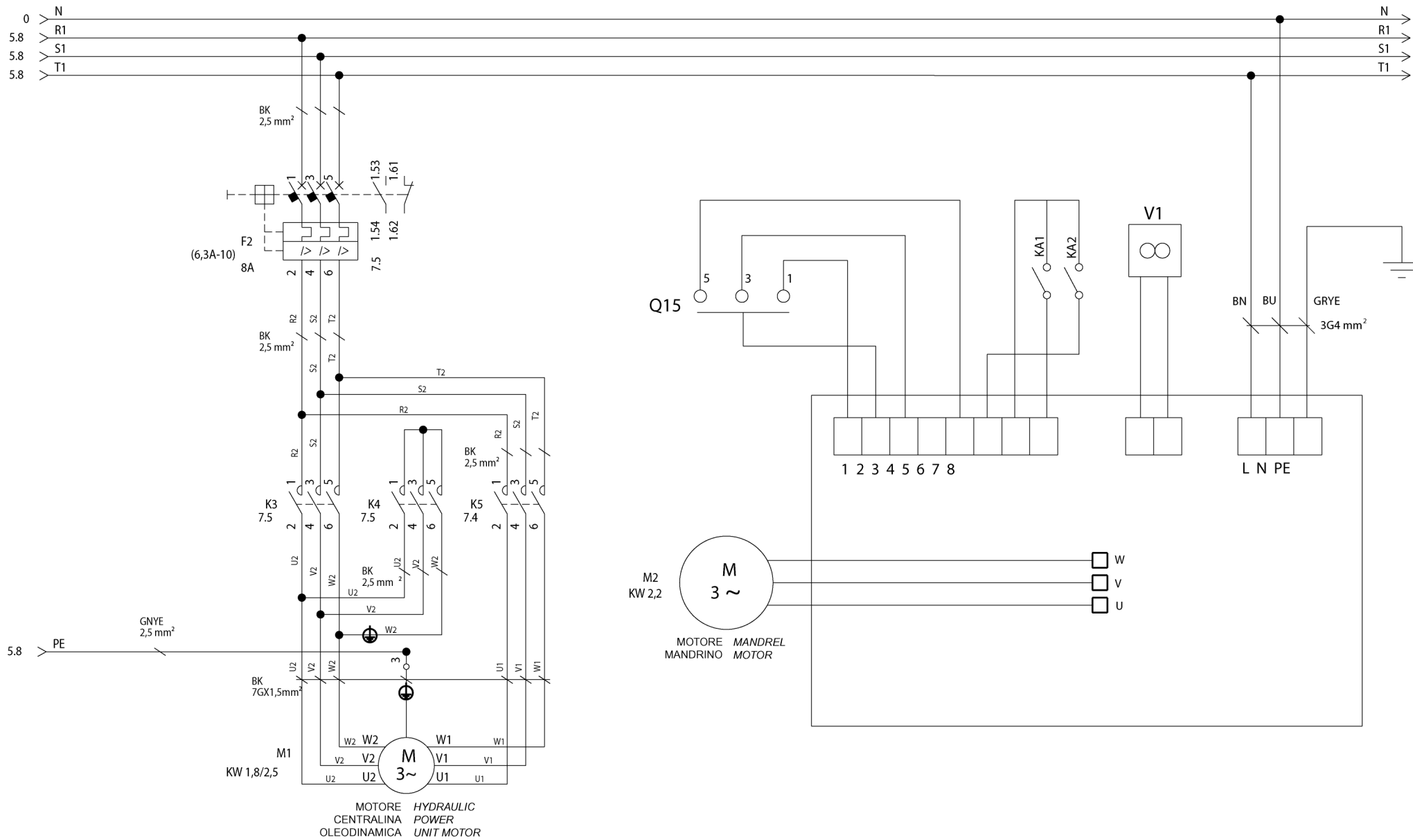
752205642

SCHEMA ELETTRICO 5/18 - ELECTRICAL SCHEME 5/18
SCHALTPLAN 5/18 - SCHEMA ELECTRIQUE 5/18
ESQUEMA ELECTRICO 5/18
(G9256.11SL - G9256.15SL (VARGNAV43AD))
(G9256D.15 - G9256TD.15 - G10360D.15 - G10360TD.15
(VARGNAVDBTH))

Pag. 142 di 168

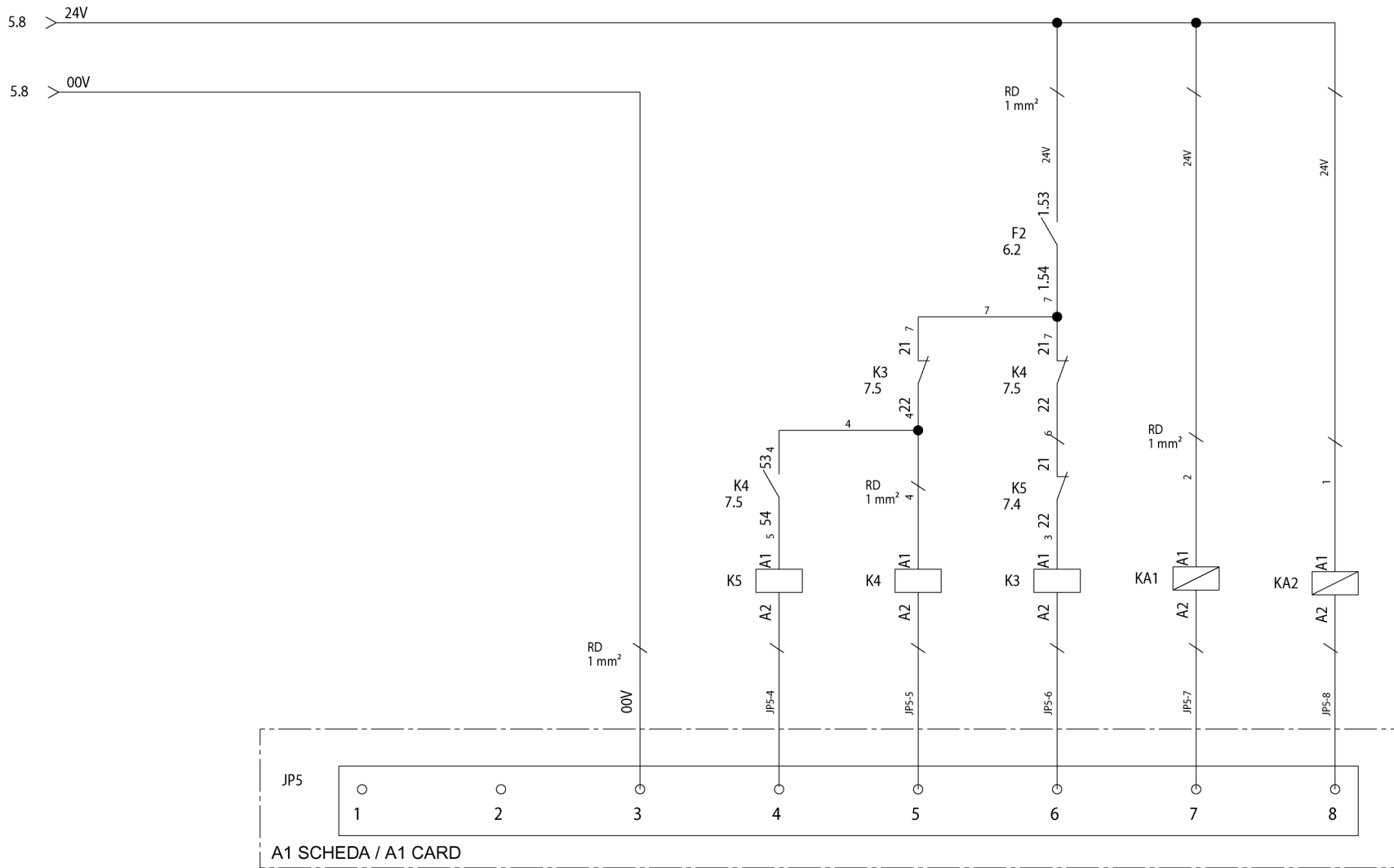
G9256.11SL - G9256.11ST - G9256.15 - G9256T.15
G9256A.15 - G9256D.15 - G9256TD.15 - G9256.15SL
G10360.15 - G10360T.15 - G10360A.15
G10360D.15 - G10360TD.15

7522-M001-14_R



MOTORE HYDRAULIC
CENTRALINA POWER
OLEODINAMICA UNIT MOTOR

MOTORE MANDREL
MANDRINO MOTOR



A1 SCHEDA / A1 CARD

- COMANDO
 ROTAZIONE
 2V CENTRALINA
 OLEODINAMICA
 2V HYDRAULIC
 POWER UNIT
 ROTATION
 CONTROL
- COMANDO
 MOTORE
 CENTRALINA
 A STELLA 2V
 2V STAR TYPE
 HYDRAULIC
 POWER UNIT
 MOTOR ROTATION
 CONTROL
- COMANDO
 ROTAZIONE
 1V CENTRALINA
 OLEODINAMICA
 1V HYDRAULIC
 POWER UNIT
 ROTATION
 CONTROL
- COMANDO
 ROTAZIONE
 ORARIA
 MANDRINO
 MANDREL
 CLOCKWISE
 ROTATION
 CONTROL
- COMANDO
 ROTAZIONE
 ANTIORARIA
 MANDRINO
 MANDREL
 COUNTERCLOCKWISE
 ROTATION
 CONTROL



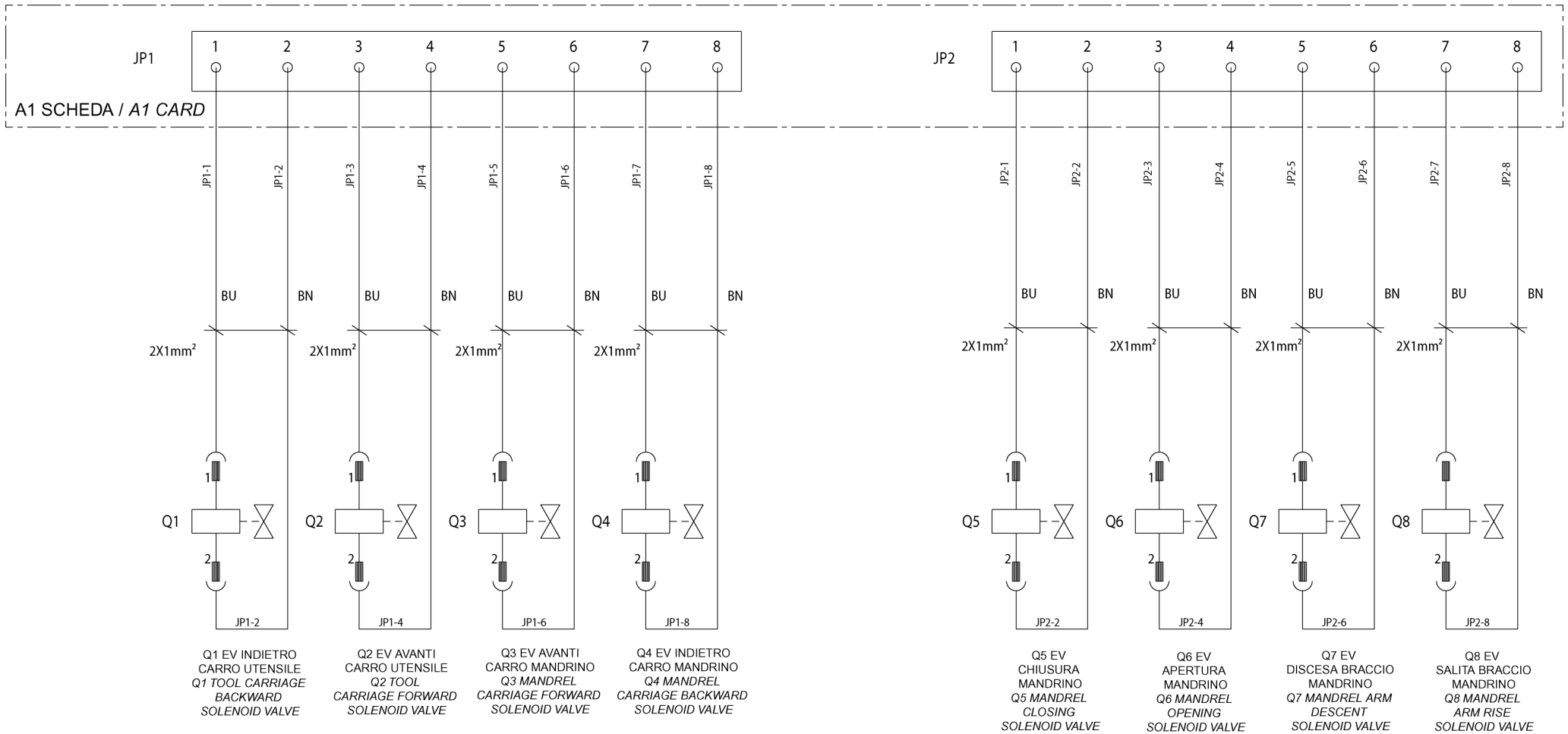
LISTA DEI COMPONENTI - LIST OF COMPONENTS - TEILELISTE
LISTE DES PIECES DETACHEES - LISTA DE PIEZAS

Tavola N°L - Rev. 0

752205642

SCHEMA ELETTRICO 7/18 - ELECTRICAL SCHEME 7/18
 SCHALTPLAN 7/18 - SCHEMA ELECTRIQUE 7/18
 ESQUEMA ELECTRICO 7/18
 (G9256.11SL - G9256.15SL (VARGNAV43AD))
 (G9256D.15 - G9256TD.15 - G10360D.15 - G10360TD.15
 (VARGNAVDBTH))

Pag. 144 di 168
 G9256.11SL - G9256.11ST - G9256.15 - G9256T.15
 G9256A.15 - G9256D.15 - G9256TD.15 - G9256.15SL
 G10360.15 - G10360T.15 - G10360A.15
 G10360D.15 - G10360TD.15



RAVAGLIOLI S.p.A.

**LISTA DEI COMPONENTI - LIST OF COMPONENTS - TEILELISTE
LISTE DES PIÈCES DÉTACHÉES - LISTA DE PIEZAS**

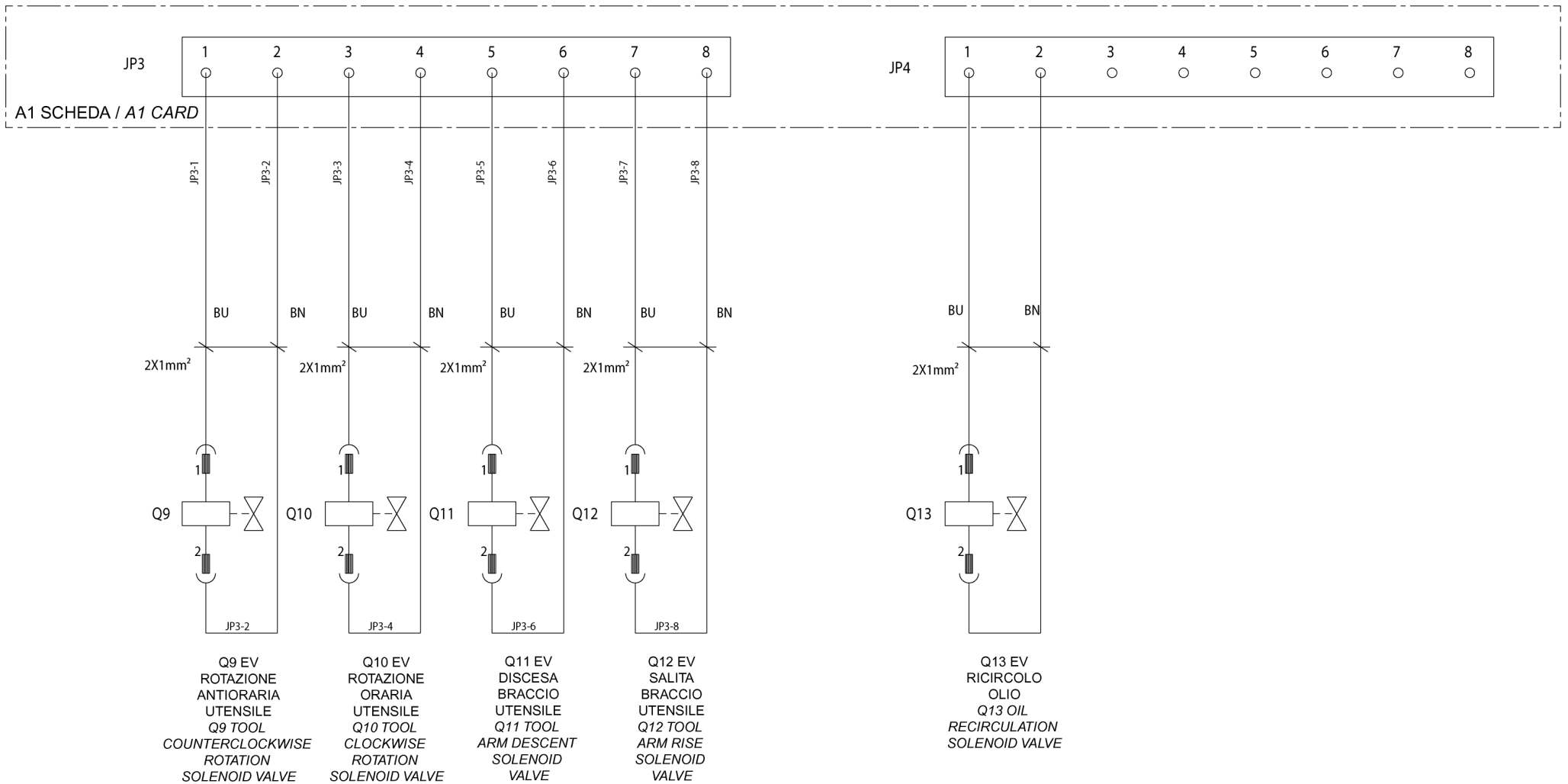
Tavola N°L - Rev. 0

752205642

SCHEMA ELETTRICO 8/18 - ELECTRICAL SCHEME 8/18
SCHALTPLAN 8/18 - SCHEMA ELECTRIQUE 8/18
ESQUEMA ELECTRICO 8/18
(G9256.11SL - G9256.15SL (VARGNAV43AD))
(G9256D.15 - G9256TD.15 - G10360D.15 - G10360TD.15
(VARGNAVDBTH))

Pag. 145 di 168

G9256.11SL - G9256.11ST - G9256.15 - G9256T.15
G9256A.15 - G9256D.15 - G9256TD.15 - G9256.15SL
G10360.15 - G10360T.15 - G10360A.15
G10360D.15 - G10360TD.15







RAVAGLIOLI S.p.A.

**LISTA DEI COMPONENTI - LIST OF COMPONENTS - TEILELISTE
LISTE DES PIECES DETACHEES - LISTA DE PIEZAS**

Tavola N°L - Rev. 0

752205642

SCHEMA ELETTRICO 11/18 - ELECTRICAL SCHEME 11/18
SCHALTPLAN 11/18 - SCHEMA ELECTRIQUE 11/18
ESQUEMA ELECTRICO 11/18
(G9256.11SL - G9256.15SL (VARGNAV43AD))
(G9256D.15 - G9256TD.15 - G10360D.15 - G10360TD.15
(VARGNAVDBTH))

Pag. 148 di 168

G9256.11SL - G9256.11ST - G9256.15 - G9256T.15
G9256A.15 - G9256D.15 - G9256TD.15 - G9256.15SL
G10360.15 - G10360T.15 - G10360A.15
G10360D.15 - G10360TD.15

IN / OUT SCHEDA TRASMITTENTE 18961

TRANSMITTING CARD 18961 IN/OUT

PIN JP1	NUMERO	FUNZIONE
1	JP1-1	S1 INDIETRO CARRO MANDRINO
2	JP1-2	S2 INDIETRO CARRO UTENSILE
3	JP1-3	S1 AVANTI CARRO MANDRINO
4	JP1-4	S2 AVANTI CARRO UTENSILE
5	JP1-5	S1 SALITA BRACCIO MANDRINO
6	JP1-6	S2 DISCESA BRACCIO UTENSILE
7	JP1-7	S1 DISCESA BRACCIO MANDRINO
8	JP1-8	S2 SALITA BRACCIO UTENSILE
9	JP1-9	S1 (COMUNE)
10	JP1-10	S2 (COMUNE)
11	JP1-11	S4 (COMUNE)
12	JP1-12	N.U.
13	JP1-13	S4 PULSANTE CHIUSURA MANDRINO
14	JP1-14	N.U.
15	JP1-15	S4 PULSANTE APERTURA MANDRINO
16	JP1-16	N.U.
17	JP1-17	S3 PULS.ROTAZ.ANTIOR. UTENS.
18	JP1-18	N.U.

PIN JP1	NUMBER	FUNCTION
1	JP1-1	S1 MANDREL CARRIAGE BACKWARD
2	JP1-2	S2 TOOL CARRIAGE BACKWARD
3	JP1-3	S1 MANDREL CARRIAGE FORWARD
4	JP1-4	S2 TOOL CARRIAGE FORWARD
5	JP1-5	S1 MANDREL ARM RISE
6	JP1-6	S2 TOOL ARM DESCENT
7	JP1-7	S1 MANDREL ARM DESCENT
8	JP1-8	S2 TOOL ARM RISE
9	JP1-9	S1 (COMMON)
10	JP1-10	S2 (COMMON)
11	JP1-11	S4 (COMMON)
12	JP1-12	N.U.
13	JP1-13	S4 MANDREL CLOSING PUSHBUTTON
14	JP1-14	N.U.
15	JP1-15	S4 MANDREL OPENING PUSHBUTTON
16	JP1-16	N.U.
17	JP1-17	S3 TOOL COUNTERCLOCKWISE ROT. PUSHBUTTON
18	JP1-18	N.U.

PIN JP6	NUMERO	FUNZIONE
1	JP6-1	S5 SELETT.ROTAZ.ANTIOR. MANDRINO
2	JP6-2	S5 SELETT.ROTAZ.ORARIA MANDRINO
3	JP6-3	S3 PULS.ROTAZ.ORARIA UTENSILE
4	JP6-4	S5 COMUNE

PIN JP6	NUMBER	FUNCTION
1	JP6-1	S5 MANDREL COUNTERCLOCKWISE ROT. SELECTOR
2	JP6-2	S5 MANDREL CLOCKWISE ROT. SELECTOR
3	JP6-3	S3 TOOL CLOCKWISE ROT. PUSHBUTTON
4	JP6-4	S5 COMMON

PIN JP2	NUMERO	FUNZIONE
1	JP2-1	G2 BATTERIA -
2	JP2-2	G2 BATTERIA +

PIN JP2	NUMBER	FUNCTION
1	JP2-1	G2 BATTERY -
2	JP2-2	G2 BATTERY +

P1	NUMERO	FUNZIONE
X1		0-12Vdc

P1	NUMBER	FUNCTION
X1		0 - 12Vdc

PIN JP9	NUMERO	FUNZIONE
1	JP9-1	S6 PULS. DOPPIA VELOC. CENTR.
2	JP9-2	N.U.
3	JP9-3	S3 (COMUNE)
4	JP9-4	S6 PULS. DOPPIA VELOC. CENTR.

PIN JP9	NUMBER	FUNCTION
1	JP9-1	S6 HYDR. POWER UNIT DOUBLE SPEED PUSHBUTTON
2	JP9-2	N.U.
3	JP9-3	S3 (COMMON)
4	JP9-4	S6 HYDR. POWER UNIT DOUBLE SPEED PUSHBUTTON

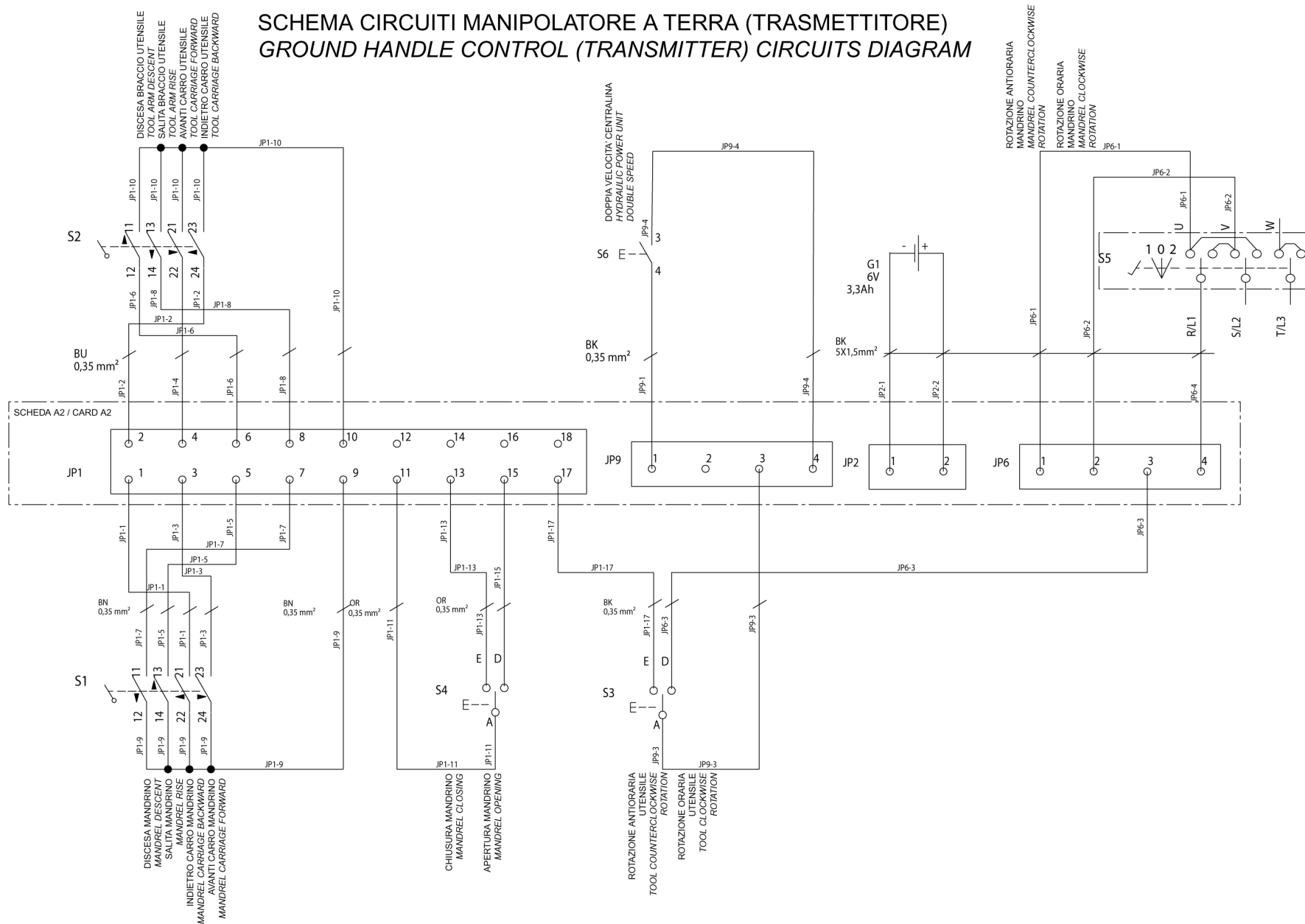
PIN JP13	NUMERO	FUNZIONE
1	JP13-1	P2 LED ROSSO +
2	JP13-2	P2 LED ROSSO -

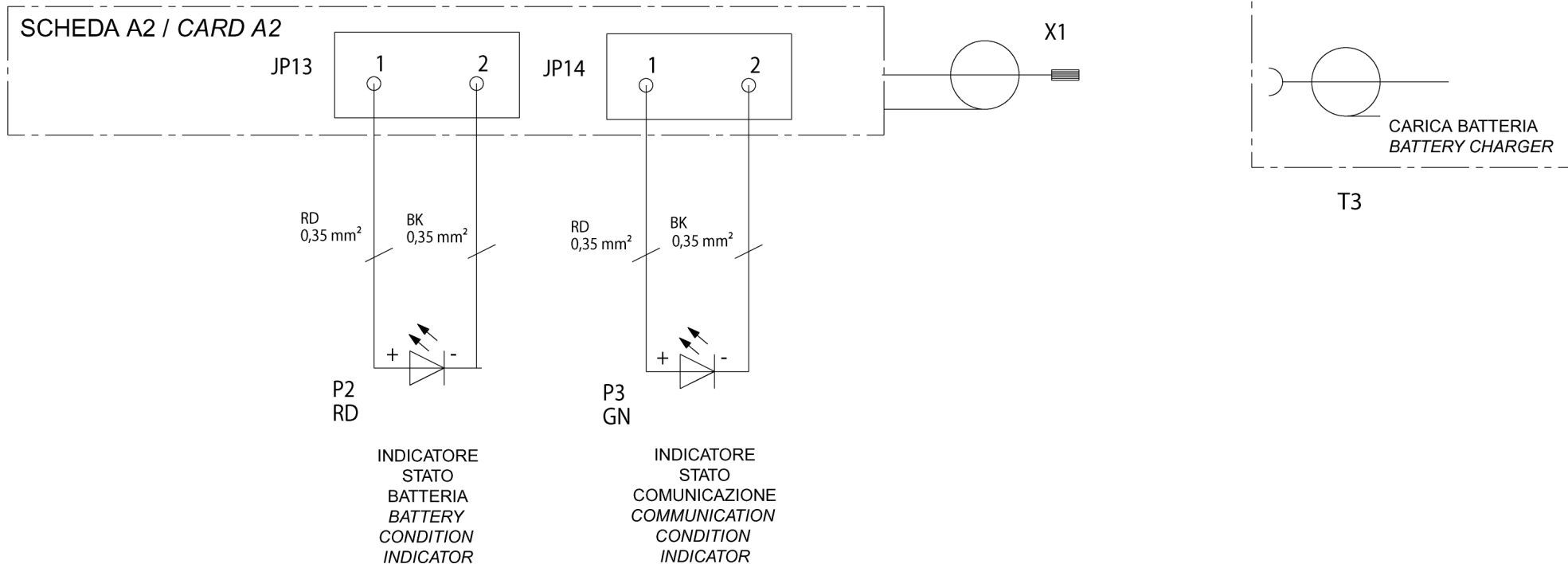
PIN JP13	NUMBER	FUNCTION
1	JP13-1	P2 RED LED +
2	JP13-2	P2 RED LED -

PIN JP14	NUMERO	FUNZIONE
1	JP14-1	P3 LED VERDE +
2	JP14-2	P3 LED VERDE -

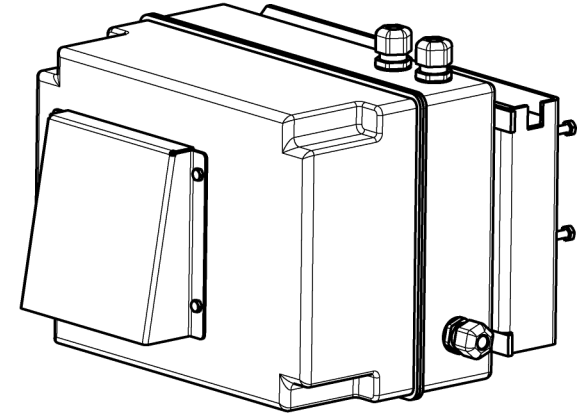
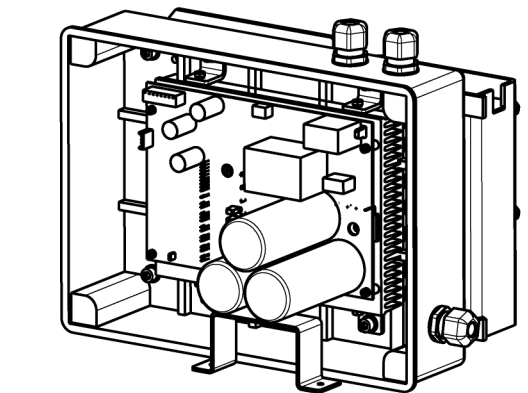
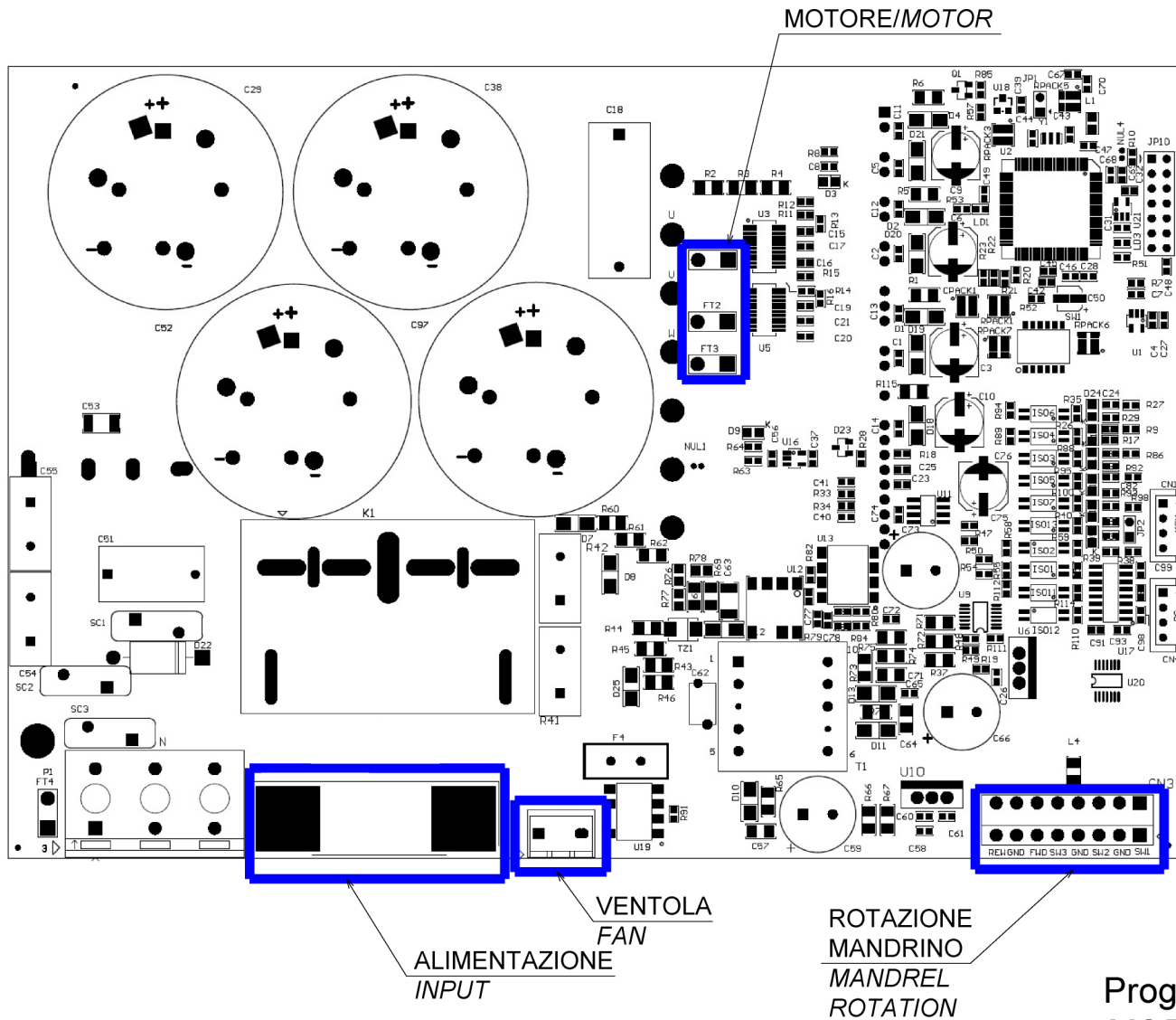
PIN JP14	NUMBER	FUNCTION
1	JP14-1	P3 GREEN LED +
2	JP14-2	P3 GREEN LED -

SCHEMA CIRCUITI MANIPOLATORE A TERRA (TRASMETTITORE)
GROUND HANDLE CONTROL (TRANSMITTER) CIRCUITS DIAGRAM





 RAVAGLIOLI S.p.A.	LISTA DEI COMPONENTI - LIST OF COMPONENTS - TEILELISTE LISTE DES PIÈCES DÉTACHÉES - LISTA DE PIEZAS		SCHEMA ELETTRICO 15/18 - ELECTRICAL SCHEME 15/18 SCHALTPLAN 15/18 - SCHEMA ELECTRIQUE 15/18 ESQUEMA ELECTRICO 15/18 (G9256.11SL - G9256.15SL (VARGNAV43AD)) (G9256D.15 - G9256TD.15 - G10360D.15 - G10360TD.15 (VARGNAVDBTH))	Pag. 152 di 168
	Tavola N°L - Rev. 0	752205642		



cod. 752293060

Programmazione MODO 2 - 752205760
 MODE 2 programming - 752205760

 RAVAGLIOLI S.p.A.	LISTA DEI COMPONENTI - LIST OF COMPONENTS - TEILELISTE LISTE DES PIÈCES DÉTACHÉES - LISTA DE PIEZAS		SCHEMA ELETTRICO 16/18 - ELECTRICAL SCHEME 16/18 SCHALTPLAN 16/18 - SCHEMA ELECTRIQUE 16/18 ESQUEMA ELECTRICO 16/18 (G9256.11SL - G9256.15SL (VARGNAV43AD)) (G9256D.15 - G9256TD.15 - G10360D.15 - G10360TD.15 (VARGNAVDBTH))	Pag. 153 di 168 <small>G9256.11SL - G9256.11ST - G9256.15 - G9256T.15 G9256A.15 - G9256D.15 - G9256TD.15 - G9256.15SL G10360.15 - G10360T.15 - G10360A.15 G10360D.15 - G10360TD.15</small>
	Tavola N°L - Rev. 0	752205642		

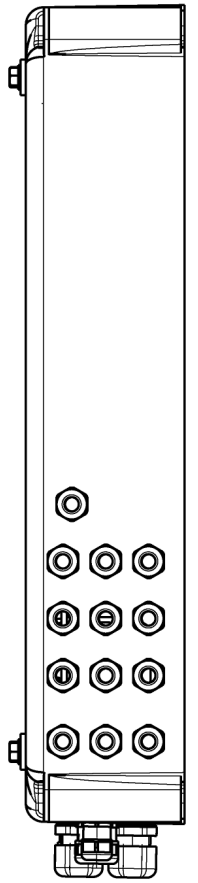
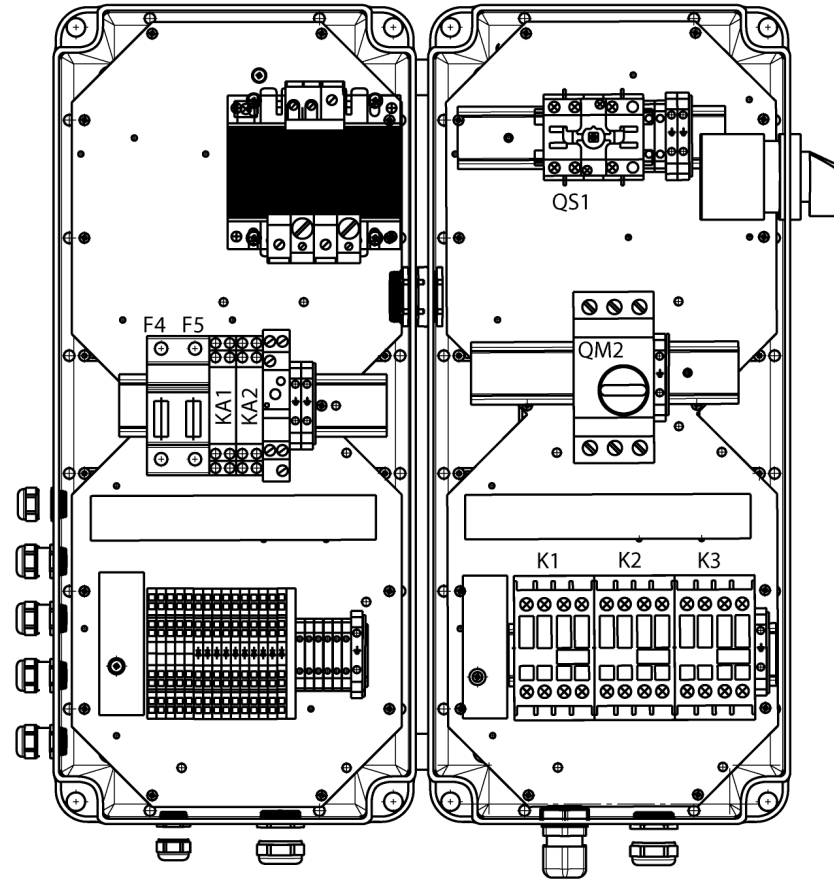
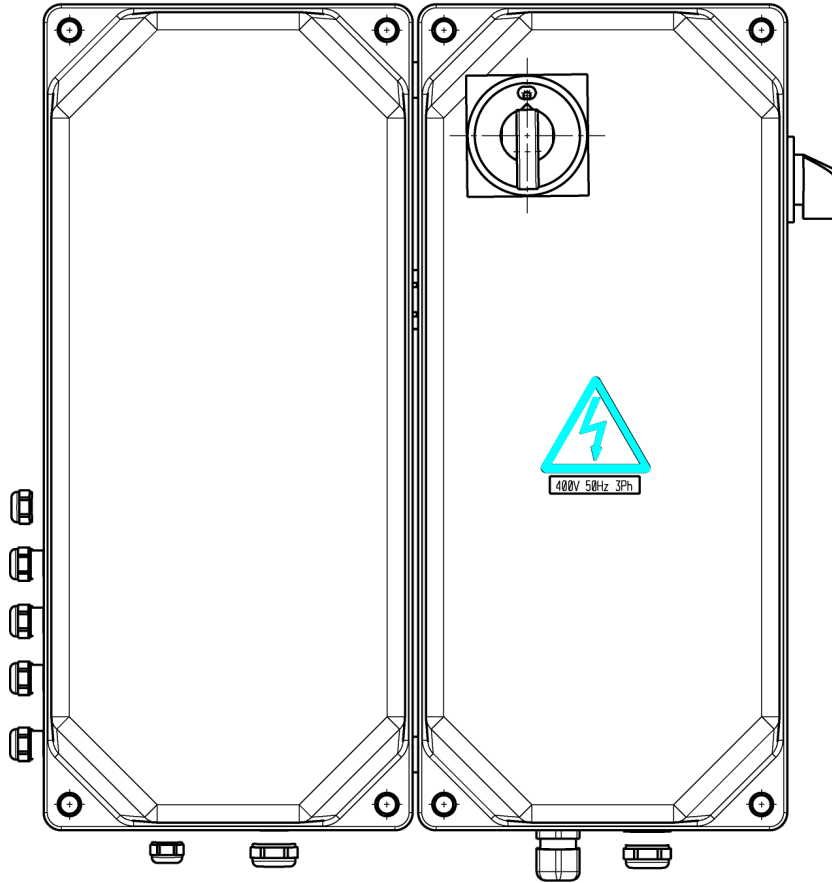
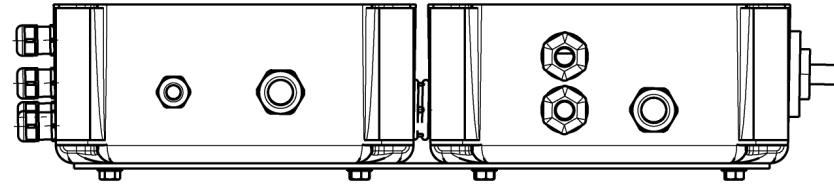
LISTA COMPONENTI

RIFERIMENTO	DESCRIZIONE	DATI TECNICI	SIGLA CATALOGO	QUANTITA	RIFERIMENTO DOCUMENTO
A1	SCHEDA ELETT. RICEVENTE	-	18962	1	2.5
A2	SCHEDA ELETT.TRASMITTENTE	-	18961	1	11.2
F2	INTERRUTTORE AUTOM. TRIPOLARE	6,3-10A AC3 400V 2,2KW	518277	1	6.2
	CONTATTI AUSILIARI	1NO+1NC ATTACCO FRONTALE	518279	1	6.2
F3	PORTAFUSIBILE	2 POLI SEZIONABILE 10,3x38 32A 690V	515027	1	5.3
	FUSIBILE	10,3X38 2A 500V RAPIDO	507019	2	
F4	FUSIBILE	5x20F 250V 2A RAPIDO	507043	1	5.3
F5	FUSIBILE	5x20F 250V 8A RAPIDO	507090	1	5.3
F6	FUSIBILE	5X20 T 8A 250V	507118	1	5.7
G1	BATTERIA	6V 3,3AH/20HR Lead	10066	1	14.6
K3	CONTATTORE TRIPOLARE	9A AC3 400V 4,2KW 1NC 24Vac 50/60Hz	522137	1	7.5
K4	CONTATTORE TRIPOLARE	9A AC3 400V 4,2KW 1NC 24Vac 50/60Hz	522137	1	7.5
	CONTATTI AUSILIARI	1NO+1NC ATTACCO FRONTALE	522147	1	7.4
K5	CONTATTORE	9A AC3 400V 4,2KW 1NC 24Vac 50/60Hz	522137	1	7.4
P2	INDICATORE LUMINOSO (LED)	ROSSO	18065	1	15.4
P3	INDICATORE LUMINOSO (LED)	VERDE	18066	1	15.5
Q1...Q13	ELETTROVALVOLE	-	-	13	8-9
Q14	SEZIONATORE TRIPOLARE	1th 32A Ui 690V-50Hz Uimp 4KW	518223+518226	1	5.2
Q15	COMM. 3POS. 25A	25A 400V	518270	1	6.7
S1	MANIPOLATORE	4 POS.+CENTR.TEMPORANEE Ø22	517157AS	1	14.2
S2	MANIPOLATORE	4 POS.+CENTR.TEMPORANEE Ø22	517157AS	1	14.2
S3	PULSANTE BASCULANTE	-	517283	1	14.5
S4	PULSANTE BASCULANTE	-	517283	1	14.4
S5	COMMUTATORE	1th 25A Ui 690V-50Hz Uimp 4KW	518058	1	14.7-14.8
S6	PULSANTE	-	517105AS	1	14.5
T1	TRASFORMATORE	200 VA 50/60 Hz PRI: 0/230/400V SEC: 0/19V 8,95A 0/24V 1,25A	528056	1	5.3
-	-	-	-	-	-
T3	CARICABATTERIA	21.6W 7.2V 3A Lithium ion	18064	1	15.6
M1	MOTORE CENTRALINA NAV63.15 NAV43.15	1,85/2,5KW 400V 50HZ 4,9/7,7A cosØ=0,73/0,70 1400/2800 rpm	900003880	1	6.3
M2	MOTORE MANDRINO	2,2KW 160/277V 50Hz 7.8/13.5A cosØ=0,78 1400rpm.	900004320	1	6.5
I1	INVERTER 43 400 (x NAV43.15)		752229790	1	6.4
	INVERTER 63 500 (x NAV63.15)		752229780	1	6.4
KA1	RELE' 2 CONTATTI 8A 24VAC		557017	1	6.5
	ZOCCOLO A 2 CONTATTI		557018	1	6.6
KA2	RELE' 2 CONTATTI 8A 24VAC		557017	1	6.6
	ZOCCOLO A 2 CONTATTI		557018	1	6.6
V1	VENTILATORE ASS.120X120 230V	120x120 230V	16718	1	6.3

 RAVAGLIOLI S.p.A.	LISTA DEI COMPONENTI - LIST OF COMPONENTS - TEILELISTE LISTE DES PIECES DETACHEES - LISTA DE PIEZAS		SCHEMA ELETTRICO 17/18 - ELECTRICAL SCHEME 17/18 SCHALTPLAN 17/18 - SCHEMA ELECTRIQUE 17/18 ESQUEMA ELECTRICO 17/18 (G9256.11SL - G9256.15SL (VARGNAV43AD)) (G9256D.15 - G9256TD.15 - G10360D.15 - G10360TD.15 (VARGNAVDBTH))	Pag. 154 di 168 <small>G9256.11SL - G9256.11ST - G9256.15 - G9256T.15 G9256A.15 - G9256D.15 - G9256TD.15 - G9256.15SL G10360.15 - G10360T.15 - G10360A.15 G10360D.15 - G10360TD.15</small>
	Tavola N°L - Rev. 0	752205642		

COMPONENTS LIST

REFERENCE	DESCRIPTION	TECHNICAL SPECIFICATIONS	ABBREVIATION ON CATALOGUE	QUANTITY	DOCUMENT REFERENCE
A1	RECEIVING ELECTRICAL CARD	-	18962	1	2.5
A2	TRANSMITTING ELECTRICAL CARD	-	18961	1	11.2
F2	TRIPOLAR AUTOMATIC SWITCH	6,3-10A AC3 400V 2,2KW	518277	1	6.2
	AUXILIARY CONTACTS	1NO+1NC FRONT COUPLING	518279	1	6.2
F3	FUSE HOLDER	10,3x38 32A 690V 2 POLES SECTIONABLE	515027	1	5.3
	FUSE	10,3x38 2A 500V RAPID	507019	2	
F4	FUSE	5x20F 250V 2A RAPID	507043	1	5.3
F5	FUSE	5x20F 250V 8A RAPID	507090	1	5.3
F6	FUSE	5X20 T 8A 250V	507118	1	5.7
G1	BATTERY	6V 3,3AH/20HR Lead	10066	1	14.6
K3	TRIPOLAR CONTACTOR	9A AC3 400V 4,2KW 1NC 24Vac 50/60Hz	522137	1	7.5
K4	TRIPOLAR CONTACTOR	9A AC3 400V 4,2KW 1NC 24Vac 50/60Hz	522137	1	7.5
	AUXILIARY CONTACTS	1NO+1NC FRONT COUPLING	522147	1	7.4
K5	CONTACTOR	9A AC3 400V 4,2KW 1NC 24Vac 50/60Hz	522137	1	7.4
P2	BACKLIGHTED INDICATOR (LED)	RED	18065	1	15.4
P3	BACKLIGHTED INDICATOR (LED)	GREEN	18066	1	15.5
Q1...Q13	SOLENOID VALVES	-	-	13	8-9
Q14	TRIPOLAR KNIFE SWITCH	Ith 32A Ui 690V-50Hz Uimp 4KW	518223+518226	1	5.2
Q15	COMM. 3POS. 25A	25A 400V	518270	1	6.7
S1	HANDLE CONTROL	4 POS.+ CENTRAL POS. TEMPORARY Ø 22	517157AS	1	14.2
S2	HANDLE CONTROL	4 POS.+ CENTRAL POS. TEMPORARY Ø 22	517157AS	1	14.2
S3	BALANCING PUSHBUTTON	-	517283	1	14.5
S4	DAHLANDER POLES COMMUTATOR	-	517283	1	14.4
S5	COMMUTATOR	Ith 25A Ui 690V-50Hz Uimp 4KW	518058	1	14.7-14.8
S6	PUSHBUTTON	-	517105AS	1	14.5
T1	TRANSFORMER	200 VA 50/60 Hz PRI: 0/230/400V SEC: 0/19V 8,95A 0/24V 1,25A	528056	1	5.3
-	-	-	-	-	-
T3	BATTERY CHARGER	21.6W 7.2V 3A Lithium ion	18064	1	15.6
M1	HYDRAULIC POWER UNIT MOTOR	1,85/2,5KW 400V 50HZ 4,9/7,7A cosØ=0,73/0,70 1400/2800 rpm	900003880	1	6.3
M2	MANDREL MOTOR	2,2KW 160/277V 50Hz 7.8/13.5A cosØ=0,78 1400rpm.	900004320	1	6.5
I1	INVERTER 43 400		752229790	1	6.4
	INVERTER 63 500		752229780	1	6.4
KA1	2 CONTACTS RELAY 8A 24 VAC		557017	1	6.5
	2 CONTACTS BASE		557018	1	6.6
KA2	2 CONTACTS RELAY 8A 24 VAC		557017	1	6.6
	2 CONTACTS BASE		557018	1	6.6
V1	FAN 120X120 230V	120x120 230V	16718	1	6.3



RAVAGLIOLI S.p.A.

**LISTA DEI COMPONENTI - LIST OF COMPONENTS - TEILELISTE
LISTE DES PIÈCES DÉTACHÉES - LISTA DE PIEZAS**

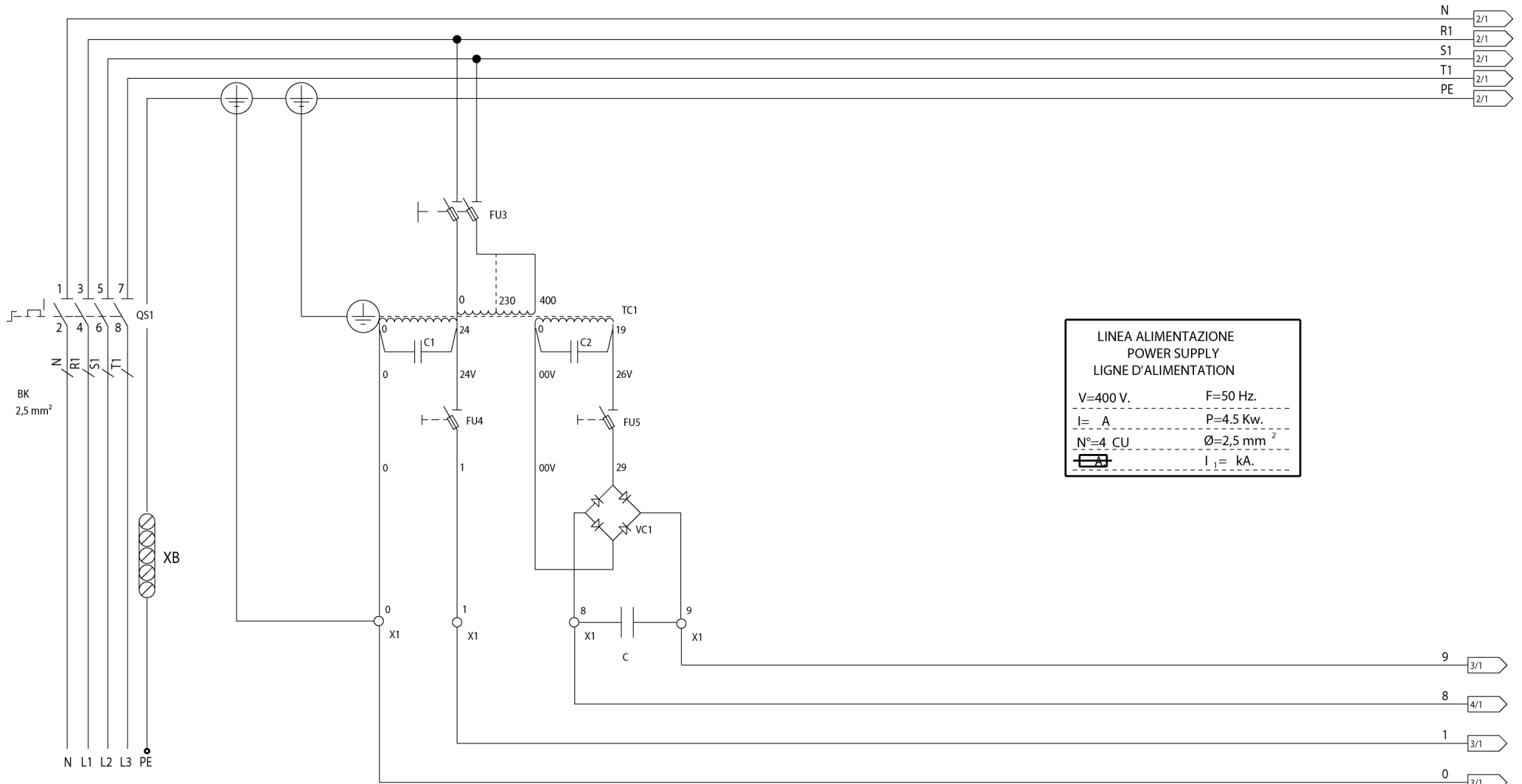
Tavola N°M - Rev. 0

752205720

SCHEMA ELETTRICO 1/9
ELECTRICAL SCHEME 1/9
SCHALTPLAN 1/9
SCHEMA ELECTRIQUE 1/9
ESQUEMA ELECTRICO 1/9
(G10360D.15 - G10360TD.15 (VARGNAV63AD))

Pag. 156 di 168

G9256.11SL - G9256.11ST - G9256.15 - G9256T.15
G9256A.15 - G9256D.15 - G9256TD.15 - G9256.15SL
G10360.15 - G10360T.15 - G10360A.15
G10360D.15 - G10360TD.15



LINEA ALIMENTAZIONE
POWER SUPPLY
LIGNE D'ALIMENTATION

V=400 V. F=50 Hz.

 I= A P=4.5 Kw.

 N°=4 CU Ø=2,5 mm²

 I₁= kA.

ALIMENTAZIONE AUXILIARIES
 AUSILIARI 24VAC SUPPLY 24VAC

ALIMENTAZIONE AUXILIARIES
 AUSILIARI 27VDC SUPPLY 27VDC



LISTA DEI COMPONENTI - LIST OF COMPONENTS - TEILELISTE
LISTE DES PIÈCES DÉTACHÉES - LISTA DE PIEZAS

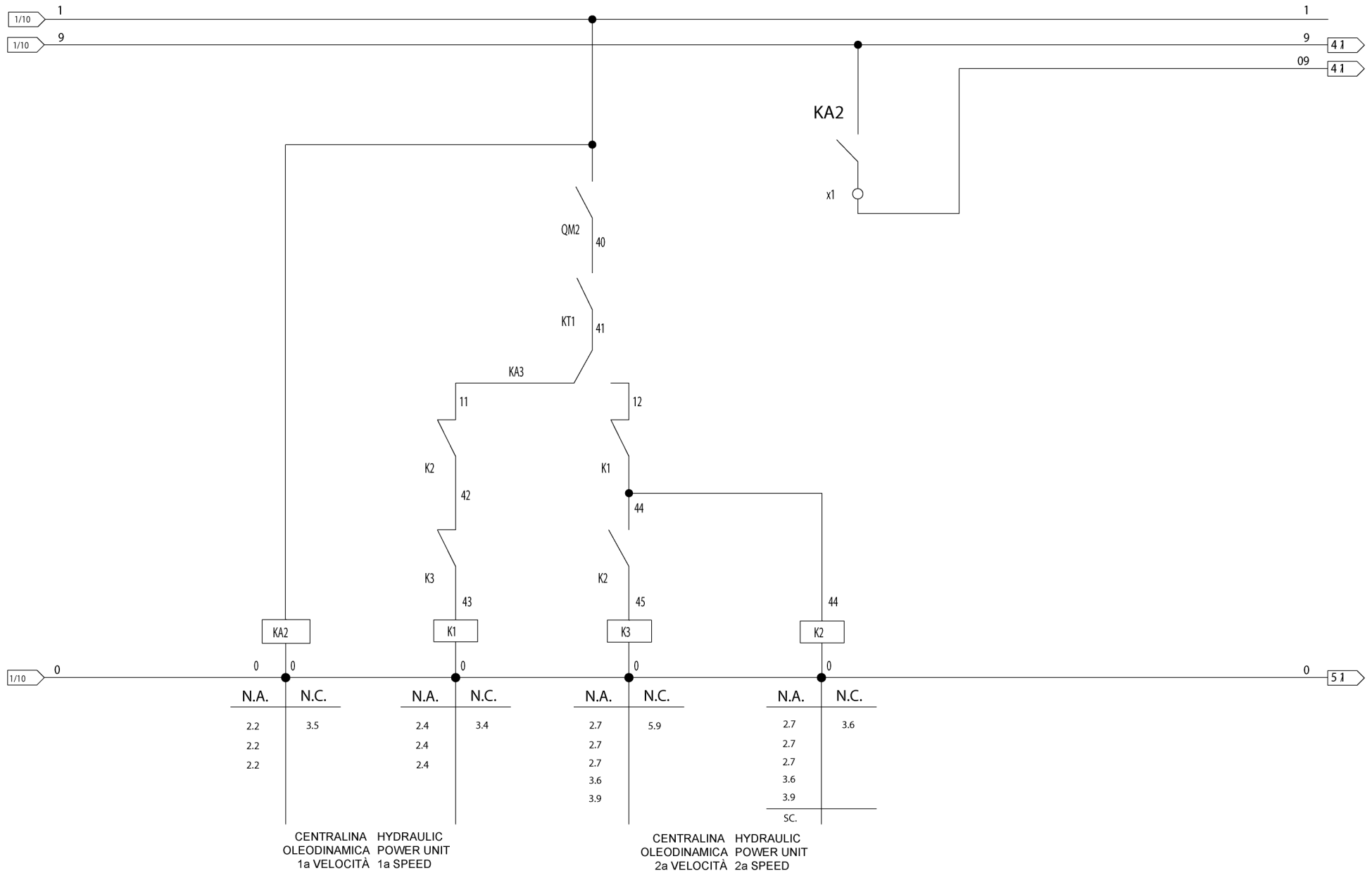
Tavola N°M - Rev. 0

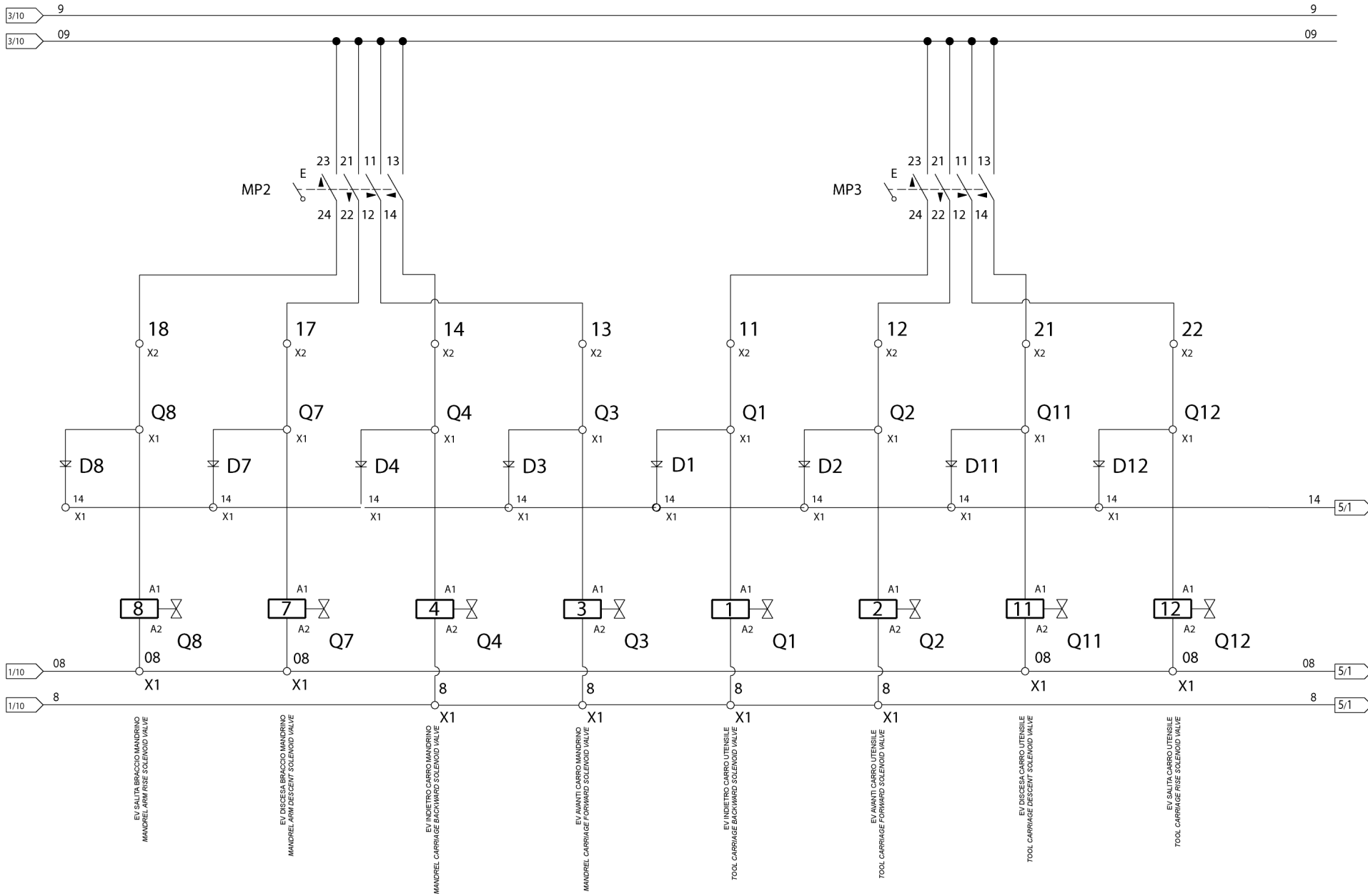
752205720

SCHEMA ELETTRICO 2/9
 ELECTRICAL SCHEME 2/9
 SCHALTPLAN 2/9
 SCHEMA ELECTRIQUE 2/9
 ESQUEMA ELECTRICO 2/9
 (G10360D.15 - G10360TD.15 (VARGNAV63AD))

Pag. 157 di 168

G9256.11SL - G9256.11ST - G9256.15 - G9256T.15
 G9256A.15 - G9256D.15 - G9256TD.15 - G9256.15SL
 G10360.15 - G10360T.15 - G10360A.15
 G10360D.15 - G10360TD.15





EV SALTURA BRACCIO MANDRINO
MANDREL ARM RISE SOLENOID VALVE

EV DISCESA BRACCIO MANDRINO
MANDREL ARM DESCENT SOLENOID VALVE

EV INDIETRO CARRO MANDRINO
MANDREL CARRIAGE BACKWARD SOLENOID VALVE

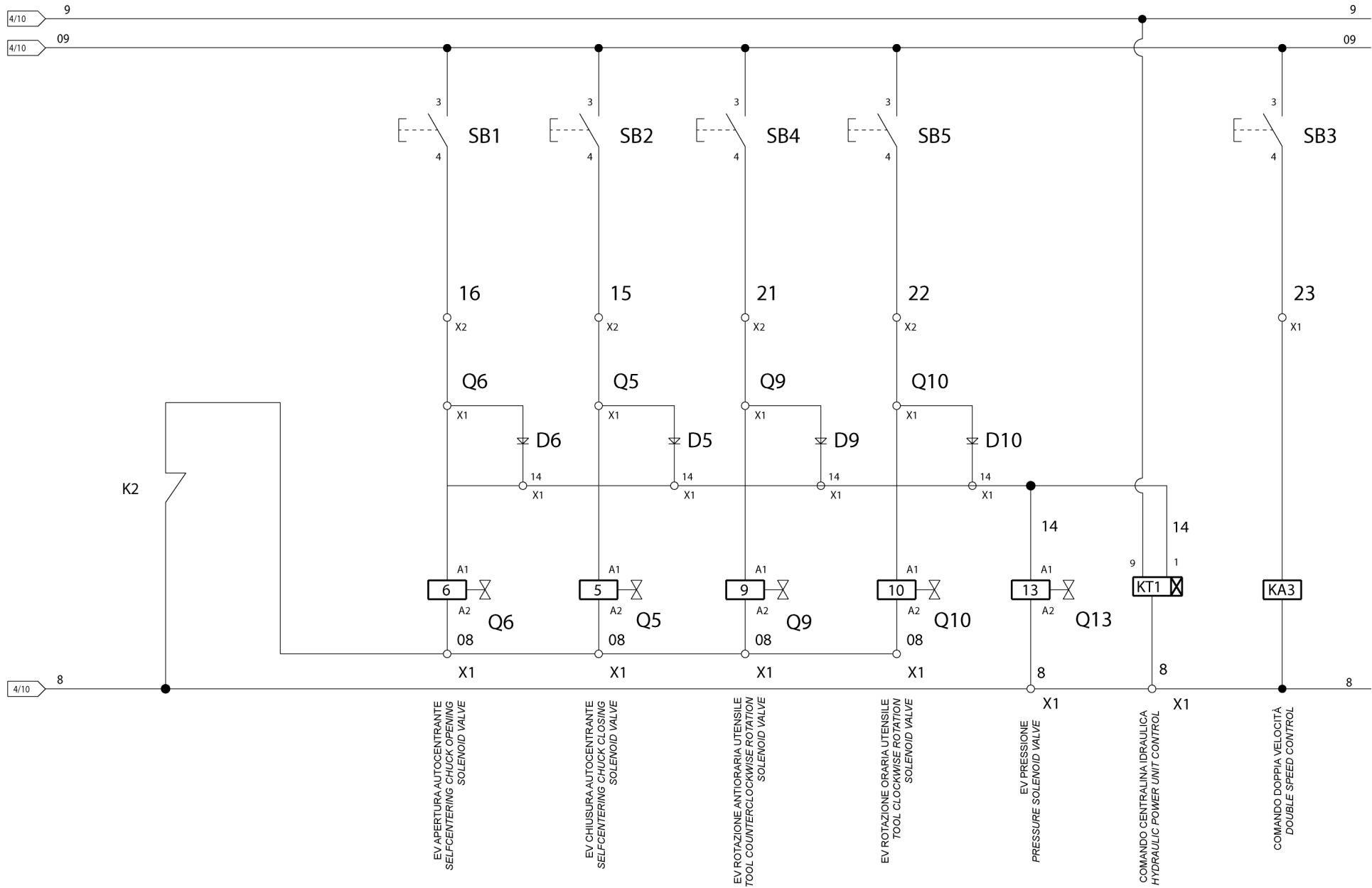
EV AVANTI CARRO MANDRINO
MANDREL CARRIAGE FORWARD SOLENOID VALVE

EV INDIETRO CARRO UTENSILE
TOOL CARRIAGE BACKWARD SOLENOID VALVE

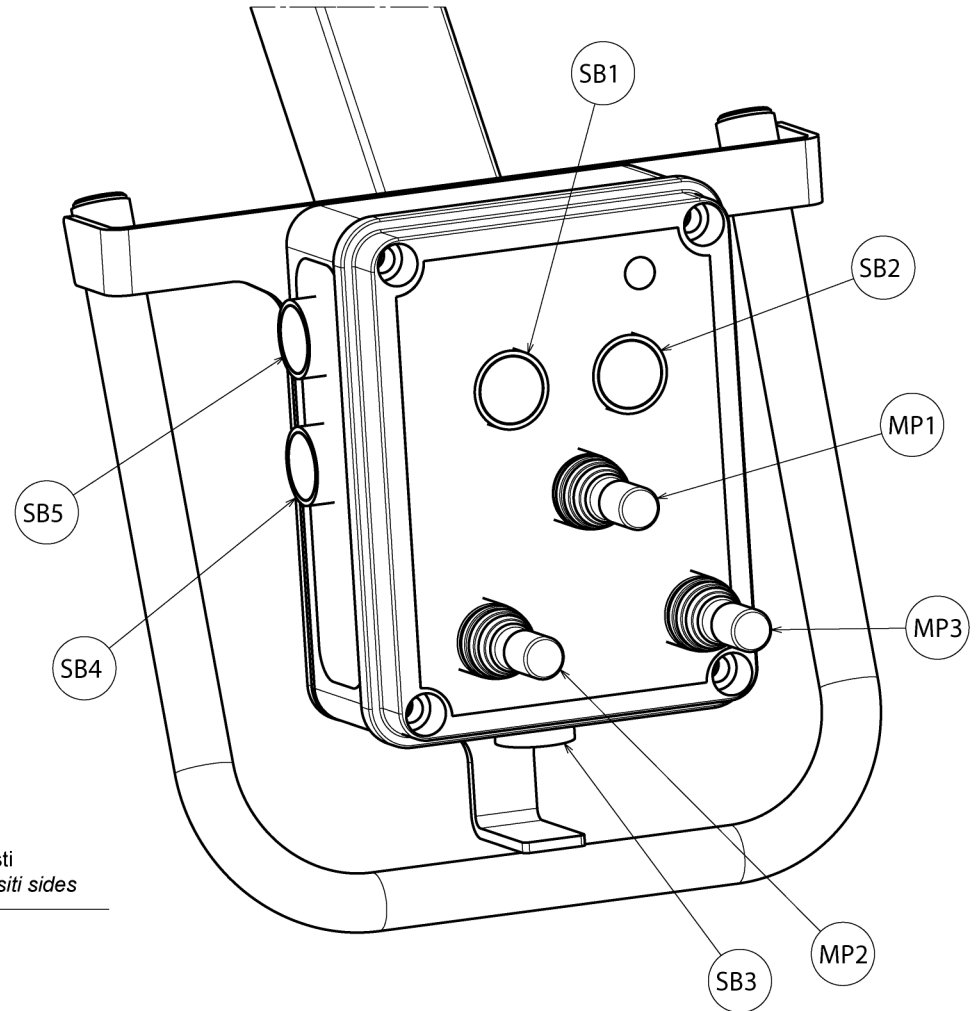
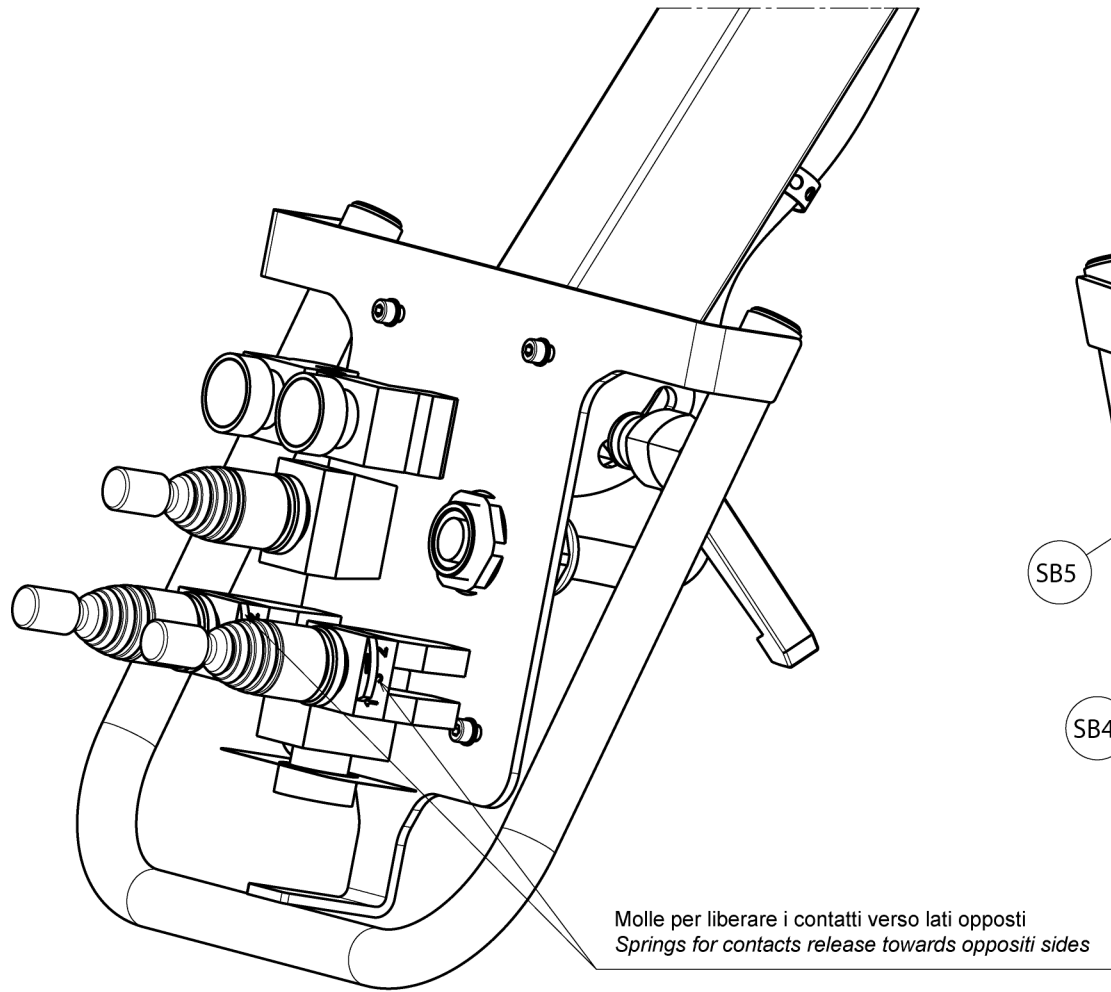
EV AVANTI CARRO UTENSILE
TOOL CARRIAGE FORWARD SOLENOID VALVE

EV DISCESA CARRO UTENSILE
TOOL CARRIAGE DESCENT SOLENOID VALVE

EV SALTURA CARRO UTENSILE
TOOL CARRIAGE RISE SOLENOID VALVE



- EV APERTURA AUTOCENTRANTE
SELF-CENTERING CHUCK OPENING
SOLENOID VALVE
- EV CHIUSURA AUTOCENTRANTE
SELF-CENTERING CHUCK CLOSING
SOLENOID VALVE
- EV ROTAZIONE ANTIORARIA UTENSILE
TOOL COUNTERCLOCKWISE ROTATION
SOLENOID VALVE
- EV ROTAZIONE ORARIA UTENSILE
TOOL CLOCKWISE ROTATION
SOLENOID VALVE
- EV PRESSIONE
PRESSURE SOLENOID VALVE
- COMANDO CENTRALINA IDRAULICA
HYDRAULIC POWER UNIT CONTROL
- COMANDO DOPPIA VELOCITÀ
DOUBLE SPEED CONTROL



 RAVAGLIOLI S.p.A.	LISTA DEI COMPONENTI - LIST OF COMPONENTS - TEILELISTE LISTE DES PIÈCES DÉTACHÉES - LISTA DE PIEZAS		SCHEMA ELETTRICO 7/9 ELECTRICAL SCHEME 7/9 SCHALTPLAN 7/9 SCHEMA ELECTRIQUE 7/9 ESQUEMA ELECTRICO 7/9 (G10360D.15 - G10360TD.15 (VARGNAV63AD))	Pag. 162 di 168 <small>G9256.11SL - G9256.11ST - G9256.15 - G9256T.15 G9256A.15 - G9256D.15 - G9256TD.15 - G9256.15SL G10360.15 - G10360T.15 - G10360A.15 G10360D.15 - G10360TD.15</small>
	Tavola N°M - Rev. 0	752205720		

LISTA COMPONENTI

RIFERIMENTO	DESCRIZIONE	DATI TECNICI	SIGLA CATALOGO	QUANTITA	RIFERIMENTO DOCUMENTO
F1	PORTAFUSIBILE	3 POLI SEZIONABILE 10,3x38 32A 690V	515025	1	6.6
	FUSIBILE	10,3x38 16A 500V aM RITARDATO	507045	3	
F2	INTERRUTTORE AUTOM. TRIPOLARE	6,3-10A AC3 400V 2,2KW	518277	1	6.2
	CONTATTI AUSILIARI	1NO+1NC ATTACCO FRONTALE	518279	1	6.2
F3	PORTAFUSIBILE	2 POLI SEZIONABILE 10,3x38 32A 690V	515027	1	5.3
	FUSIBILE	10,3X38 2A 500V RAPIDO	507019	2	
F4	FUSIBILE	5x20F 250V 2A RAPIDO	507043	1	5.3
F5	FUSIBILE	5x20F 250V 8A RAPIDO	507090	1	5.3
F6	FUSIBILE	5X20 T 8A 250V	507118	1	5.7
G1	BATTERIA	6V 3,3AH/20HR Lead	10066	1	14.6
K1	CONTATTORE TRIPOLARE	9A AC3 400V 4,2KW 1NC 24Vac 50/60Hz	522137	1	7.6
K2	CONTATTORE TRIPOLARE	9A AC3 400V 4,2KW 1NC 24Vac 50/60Hz	522137	1	7.6
K3	CONTATTORE TRIPOLARE	9A AC3 400V 4,2KW 1NC 24Vac 50/60Hz	522137	1	7.5
K4	CONTATTORE TRIPOLARE	9A AC3 400V 4,2KW 1NC 24Vac 50/60Hz	522137	1	7.5
	CONTATTI AUSILIARI	1NO+1NC ATTACCO FRONTALE	522147	1	7.4
K5	CONTATTORE	9A AC3 400V 4,2KW 1NC 24Vac 50/60Hz	522137	1	7.4
P2	INDICATORE LUMINOSO (LED)	ROSSO	18065	1	15.4
P3	INDICATORE LUMINOSO (LED)	VERDE	18066	1	15.5
Q1...Q13	ELETTROVALVOLE	-	-	13	8-9
Q14	SEZIONATORE TRIPOLARE	1th 32A Ui 690V-50Hz Uimp 4KW	518223+518226	1	5.2
Q15	COMMUTATORE DI POLI DAHLANDER	25A 500V	518189	1	6.5-6.6
MP3	MANIPOLATORE	MANIPOLATORE C 4 POS. TEMPORANEE	517285	1	14.2
MP2	MANIPOLATORE	MANIPOLATORE C 4 POS. TEMPORANEE	517285	1	14.2
MP1	MANIPOLATORE	MANIPOLATORE C 2 POS. TEMPORANEE	517286	-	-
SB1	PULSANTE	PULSANTE IP 55	4511000	1	14.4
SB2	PULSANTE	PULSANTE IP 55	4511000	1	14.7-14.8
SB3	PULSANTE	PULSANTE IP 55	4511000	1	14.5
SB4	PULSANTE	PULSANTE IP 55	4511000	1	14.5
SB5	PULSANTE	PULSANTE IP 55	4511000	1	14.5
T1	TRASFORMATORE	200 VA 50/60 Hz PRI: 0/230/400V SEC: 0/19V 8,95A 0/24V 1,25A	528056	1	5.3
M1	MOTORE CENTRALINA	1,85/2,5KW 400V 50HZ 4,9/7,7A cosφ=0,73/0,70 1400/2800 rpm	900003880	1	6.3
M2	MOTORE MANDRINO	1,35/1,85KW 400V 50Hz 1400/2800rpm	900003930	1	



RAVAGLIOLI S.p.A.

**LISTA DEI COMPONENTI - LIST OF COMPONENTS - TEILELISTE
LISTE DES PIÈCES DÉTACHÉES - LISTA DE PIEZAS**

Tavola N°M - Rev. 0

752205720

SCHEMA ELETTRICO 8/9
ELECTRICAL SCHEME 8/9
SCHALTPLAN 8/9
SCHEMA ELECTRIQUE 8/9
ESQUEMA ELECTRICO 8/9
(G10360D.15 - G10360TD.15 (VARGNAV63AD))

Pag. 163 di 168

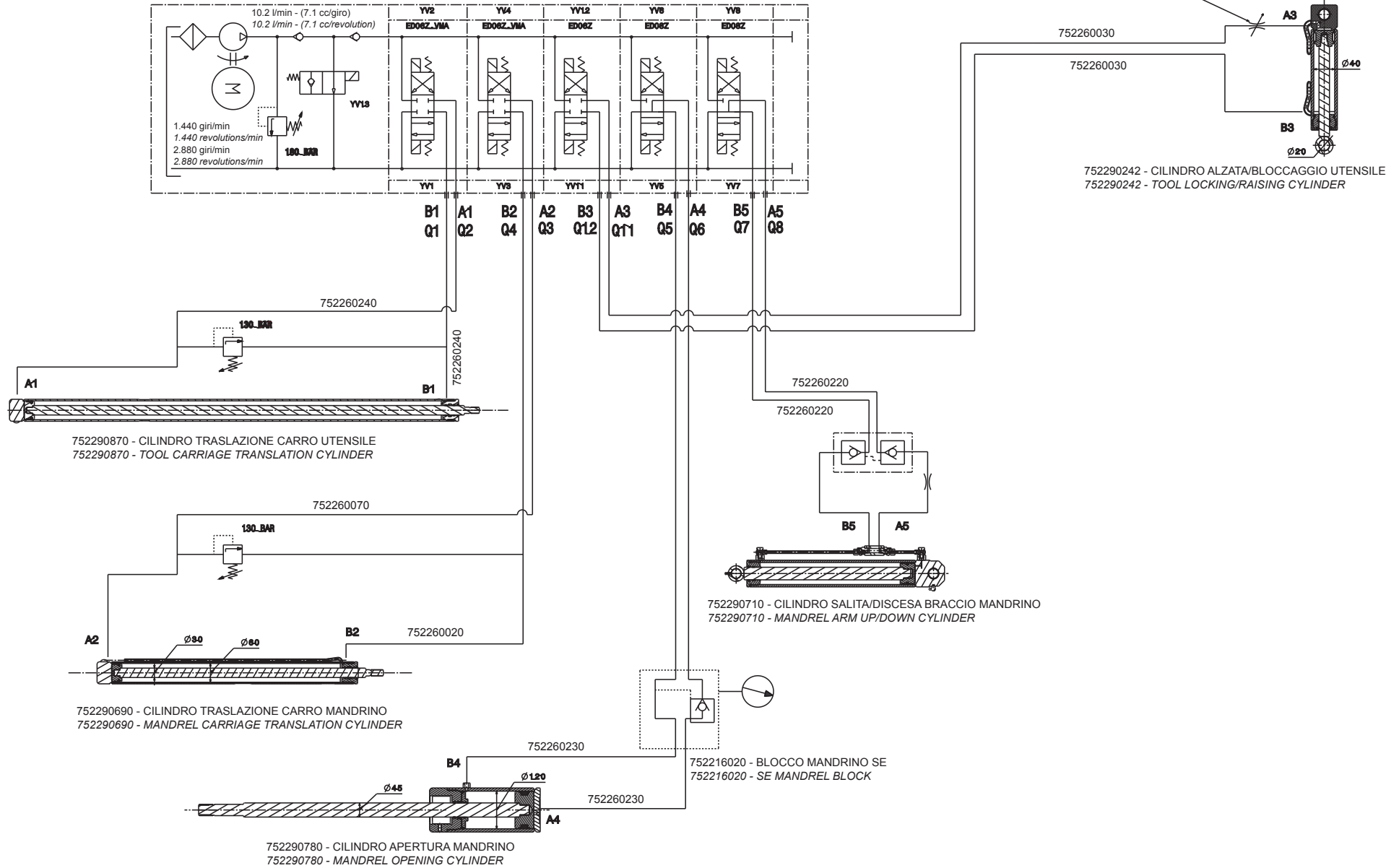
G9256.11SL - G9256.11ST - G9256.15 - G9256T.15
G9256A.15 - G9256D.15 - G9256TD.15 - G9256.15SL
G10360.15 - G10360T.15 - G10360A.15
G10360D.15 - G10360TD.15

7522-M001-14_R

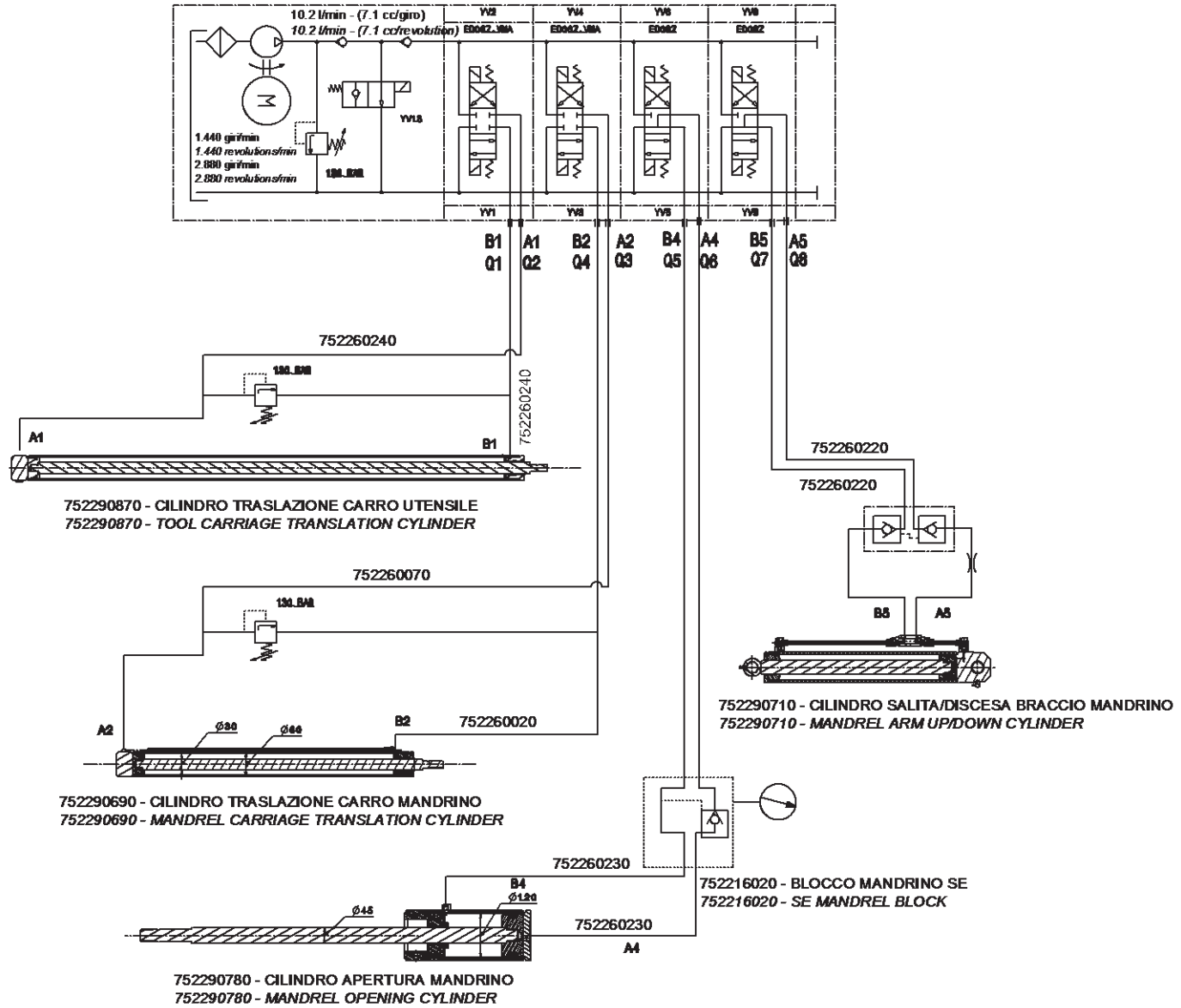
COMPONENTS LIST

REFERENCE	DESCRIPTION	TECHNICAL SPECIFICATIONS	ABBREVIATION ON CATALOGUE	QUANTITY	DOCUMENT REFERENCE
F1	FUSE HOLDER	10,3x38 32A 690V SECTIONABLE 3 POLES	515025	1	6.6
	FUSE	10,3x38 16A 500V aM DELAYED-ACTION	507045	3	
F2	TRIPOLAR AUTOMATIC SWITCH	6,3-10A AC3 400V 2,2KW	518277	1	6.2
	AUXILIARY CONTACTS	1NO+1NC FRONT COUPLING	518279	1	6.2
F3	FUSE HOLDER	10,3x38 32A 690V 2 POLES SECTIONABLE	515027	1	5.3
	FUSE	10,3x38 2A 500V RAPID	507019	2	
F4	FUSE	5x20F 250V 2A RAPID	507043	1	5.3
F5	FUSE	5x20F 250V 8A RAPID	507090	1	5.3
F6	FUSE	5X20 T 8A 250V	507118	1	5.7
G1	BATTERY	6V 3,3AH/20HR Lead	10066	1	14.6
K1	TRIPOLAR CONTACTOR	9A AC3 400V 4,2KW 1NC 24Vac 50/60Hz	522137	1	7.6
K2	TRIPOLAR CONTACTOR	9A AC3 400V 4,2KW 1NC 24Vac 50/60Hz	522137	1	7.6
K3	TRIPOLAR CONTACTOR	9A AC3 400V 4,2KW 1NC 24Vac 50/60Hz	522137	1	7.5
K4	TRIPOLAR CONTACTOR	9A AC3 400V 4,2KW 1NC 24Vac 50/60Hz	522137	1	7.5
	AUXILIARY CONTACTS	1NO+1NC FRONT COUPLING	522147	1	7.4
K5	CONTACTOR	9A AC3 400V 4,2KW 1NC 24Vac 50/60Hz	522137	1	7.4
P2	BACKLIGHTED INDICATOR (LED)	RED	18065	1	15.4
P3	BACKLIGHTED INDICATOR (LED)	GREEN	18066	1	15.5
Q1...Q13	SOLENOID VALVES	-	-	13	8-9
Q14	TRIPOLAR KNIFE SWITCH	1th 32A Ui 690V-50Hz Uimp 4KW	518223+518226	1	5.2
Q15	DAHLANDER POLES COMMUTATOR	25A 500V	518189	1	6.5-6.6
MP3	HANDLE CONTROL	HANDLE CONTROL C4 POS. TEMPORARY	517285	1	14.2
MP2	HANDLE CONTROL	HANDLE CONTROL C4 POS. TEMPORARY	517285	1	14.2
MP1	HANDLE CONTROL	HANDLE CONTROL C2 POS. TEMPORARY	517286	-	-
SB1	PUSHBUTTON	IP55 PUSHBUTTON	4511000	1	14.4
SB2	PUSHBUTTON	IP55 PUSHBUTTON	4511000	1	14.7-14.8
SB3	PUSHBUTTON	IP55 PUSHBUTTON	4511000	1	14.5
SB4	PUSHBUTTON	IP55 PUSHBUTTON	4511000	1	14.5
SB5	PUSHBUTTON	IP55 PUSHBUTTON	4511000	1	14.5
T1	TRANSFORMER	200 VA 50/60 Hz PRI: 0/230/400V SEC: 0/19V 8,95A 0/24V 1,25A	528056	1	5.3
M1	HYDRAULIC POWER UNIT MOTOR	1,85/2,5KW 400V 50HZ 4,9/7,7A cos ϕ =0,73/0,70 1400/2800 rpm	900003880	1	6.3
M2	MANDREL MOTOR	1,35/1,85KW 400V 50Hz 1400/2800rpm	900003930	1	

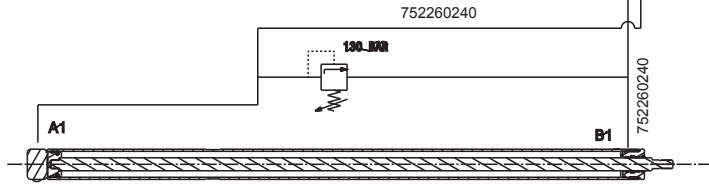
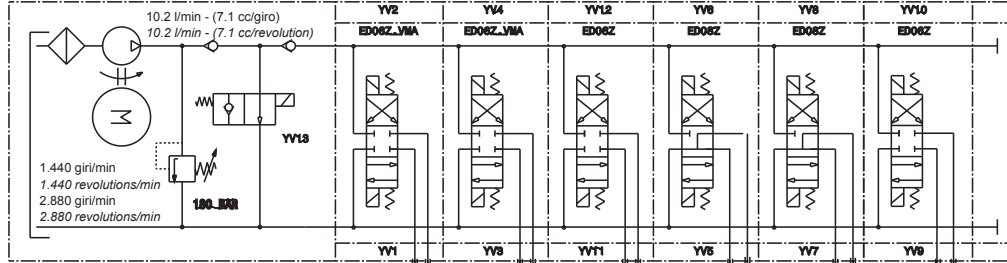
CODICE CENTRALINA: 752229360
 POWER UNIT CODE: 752229360



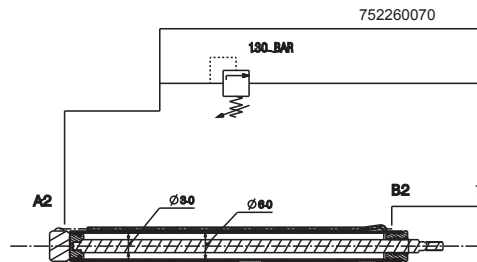
CODICE CENTRALINA: 75226040
 POWER UNIT CODE: 75226040



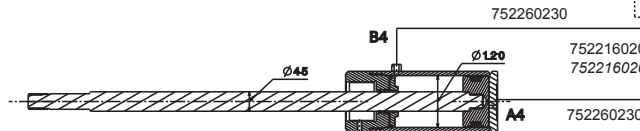
CODICE CENTRALINA: 752216350
 POWER UNIT CODE: 752216350



752290530 - CILINDRO TRASLAZIONE CARRO UTENSILE
 752290530 - TOOL CARRIAGE TRANSLATION CYLINDER



752290410 - CILINDRO TRASLAZIONE CARRO MANDRINO
 752290410 - MANDREL CARRIAGE TRANSLATION CYLINDER

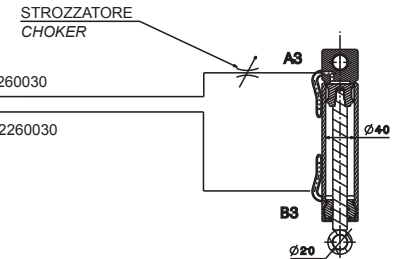


752290780 - CILINDRO APERTURA MANDRINO
 752290780 - MANDREL OPENING CYLINDER

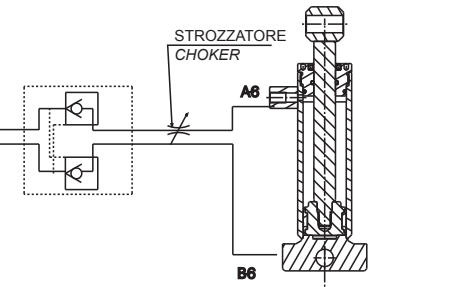
752216020 - BLOCCO MANDRINO SE
 752216020 - SE MANDREL BLOCK



752290710 - CILINDRO SALITA/DISCESA BRACCIO MANDRINO
 752290710 - MANDREL ARM UP/DOWN CYLINDER

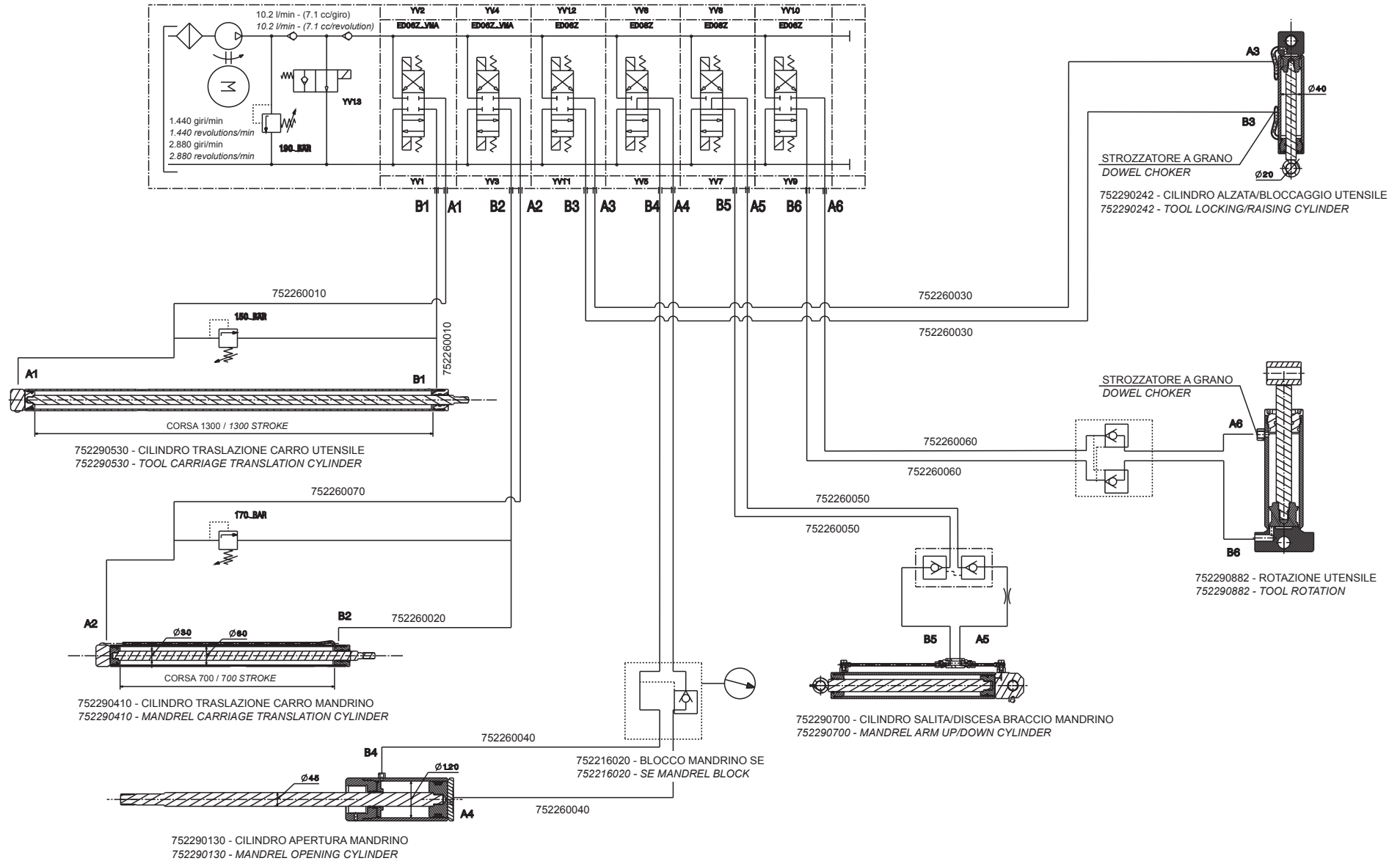


752290242 - CILINDRO ALZATA/BLOCCAGGIO UTENSILE
 752290242 - TOOL LOCKING/RAISING CYLINDER



752290882 - ROTAZIONE UTENSILE
 752290882 - TOOL ROTATION

CODICE CENTRALINA: 752216350
 POWER UNIT CODE: 752216350





7522-R001-12_R

**G9256.11SL - G9256.11ST
G9256.15 - G9256T.15 - G9256A.15
G9256D.15 - G9256TD.15
G9256.15SL
G10360.15 - G10360T.15 - G10360A.15
G10360D.15 - G10360TD.15**

- I** 20.0 LISTA DEI COMPONENTI
- GB** 20.0 LIST OF COMPONENTS
- D** 20.0 TEILELISTE
- F** 20.0 LISTE DES PIÈCES DETACHÉES
- E** 20.0 LISTA DE PIEZAS



GLI ESPLOSI SERVONO SOLO PER L'IDENTIFICAZIONE DELLE PARTI DA SOSTITUIRE. LA SOSTITUZIONE DEVE ESSERE EFFETTUATA DA PERSONALE PROFESSIONALMENTE QUALIFICATO.



THE DIAGRAMS SERVE ONLY FOR THE IDENTIFICATION OF PARTS TO BE REPLACED. THE REPLACEMENT MUST BE CARRIED OUT PROFESSIONALLY QUALIFIED PERSONNEL.



DIE ZEICHNUNGEN DIENEN NUR ZUR IDENTIFIZIERUNG DER ERSATZTEILE. DIE ERSETZUNG MUSS DURCH QUALIFIZIERTES PERSONAL ERFOLGEN.



LES DESSINS NE SERVENT QU'À L'IDENTIFICATION DES PIÈCES À REMPLACER. LE REMPLACEMENT DOIT ÊTRE EFFECTUÉ PAR UN PERSONNE PROFESSIONNELLEMENT QUALIFIÉ.



LOS DIBUJOS EN DESPIECE SIRVEN ÚNICAMENTE PARA IDENTIFICAR LAS PIEZAS QUE DEBEN SUSTITUIRSE. LA SUSTITUCIÓN DE PIEZAS DEBE EFECTUARLA EXCLUSIVAMENTE PERSONAL PROFESIONALMENTE CUALIFICADO.

- Per eventuali chiarimenti interpellare il più vicino rivenditore oppure rivolgersi direttamente a:
- For any further information please contact your local dealer or call:
- Im Zweifelsfall oder bei Rückfragen wenden Sie sich bitte an den nächsten Wiederverkäufer oder direkt an:
- Pour tout renseignement complémentaire s'adresser au revendeur le Plus proche ou directement à:
- En caso de dudas, para eventuales aclaraciones, póngase en contacto con el distribuidor más próximo ó diríjase directamente a:

Technical services: **RAVAGLIOLI S.p.A.** - Via 1° Maggio, 3 - 40037 Pontecchio Marconi - Bologna Italy
Phone (+39) 051 6781511 - Telex 510697 RAV I - Fax (+39) 051 846349 - e-mail: aftersales@ravaglioli.com

7522-R001-12_R - Rev. n. 12 (07/2017)



RAVAGLIOLI S.p.A.

**LISTA DEI COMPONENTI
LIST OF COMPONENTS
TEILELISTE
LISTE DES PIÈCES DÉTACHÉES
LISTA DE PIEZAS**

Pag. 2 di 76

G9256.11SL - G9256.11ST - G9256.15
G9256T.15 - G9256A.15 - G9256D.15
G9256TD.15 - G9256.15SL
G10360.15 - G10360T.15 - G10360A.15
G10360D.15 - G10360TD.15

7522-R001-12_R

**SOMMARIO - SUMMARY - INHALT
SOMMAIRE - SUMARIO**

<p>Tavola N°1 - Rev. 4 _____ 9</p> <p>ASSIEME GENERALE MAIN ASSEMBLY GENERALSATZ ASSEMBLAGE GENERAL JUNTO GENERAL</p>	<p>Tavola N°12 - Rev. 1 _____ 752290780..... 20</p> <p>CILINDRO AUTOCENTRANTE SELF-CENTERING CYLINDER AUTOZENTRIERZYLINDER CYLINDRE AUTOCENTREUR CILINDRO AUTOCENTRANTE</p>
<p>Tavola N°2 - Rev. 4 _____ 10</p> <p>ASSIEME GENERALE MAIN ASSEMBLY GENERALSATZ ASSEMBLAGE GENERAL JUNTO GENERAL</p>	<p>Tavola N°13 - Rev. 5 _____ 752290770..... 21</p> <p>ASSIEME BRACCIO MANDRINO MANDREL ARM ASSEMBLY SPINDELSARMENSEMBLE ASSEMBLAGE BRAS MANDRIN ENSEMBLADO BRAZO MANDRIL</p>
<p>Tavola N°3 - Rev. 6 _____ 11</p> <p>ASSIEME GENERALE MAIN ASSEMBLY GENERALSATZ ASSEMBLAGE GENERAL JUNTO GENERAL</p>	<p>Tavola N°14 - Rev. 0 _____ 752290790..... 22</p> <p>GRUPPO MOTORE ELETTRICO ELECTRIC MOTOR UNIT ELEKTRISCHER MOTORSATZ GROUPE MOTEUR ÉLECTRIQUE GRUPO MOTOR ELÉCTRICO</p>
<p>Tavola N°4 - Rev. 3 _____ 12</p> <p>ASSIEME GENERALE MAIN ASSEMBLY GENERALSATZ ASSEMBLAGE GENERAL JUNTO GENERAL</p>	<p>Tavola N°15 - Rev. 5 _____ 752290170..... 23</p> <p>GRUPPO BRACCIO MANDRINO MANDREL ARM UNIT SPINDELARMSATZ GROUPE BRAS MANDRIN GRUPO BRAZO MANDRIL</p>
<p>Tavola N°5 - Rev. 4 _____ 13</p> <p>ASSIEME GENERALE MAIN ASSEMBLY GENERALSATZ ASSEMBLAGE GENERAL JUNTO GENERAL</p>	<p>Tavola N°16 - Rev. 1 _____ 752290130..... 24</p> <p>CILINDRO CYLINDER ZYLINDER CYLINDRE CILINDRO</p>
<p>Tavola N°6 - Rev. 5 _____ 14</p> <p>ASSIEME GENERALE MAIN ASSEMBLY GENERALSATZ ASSEMBLAGE GENERAL JUNTO GENERAL</p>	<p>Tavola N°17 - Rev. 1 _____ 752290250..... 25</p> <p>GRUPPO BRACCI MANDRINO MANDREL ARMS UNIT SPINDELSARMSATZ GROUPE BRAS MANDRIN GRUPO BRAZOS MANDRIL</p>
<p>Tavola N°7 - Rev. 3 _____ 15</p> <p>ASSIEME GENERALE MAIN ASSEMBLY GENERALSATZ ASSEMBLAGE GENERAL JUNTO GENERAL</p>	<p>Tavola N°18 - Rev. 1 _____ B9641000 26</p> <p>GRIFFA COMPLETA COMPLETE JAW KOMPLLETTE KLAUE GRIFFE COMPLÈTE GANCHO COMPLETO</p>
<p>Tavola N°8 - Rev. 5 _____ 16</p> <p>ASSIEME GENERALE MAIN ASSEMBLY GENERALSATZ ASSEMBLAGE GENERAL JUNTO GENERAL</p>	<p>Tavola N°19 - Rev. 1 _____ 752291080..... 27</p> <p>SUPPORTO CON PATTINI SUPPORT WITH SLIDING BLOCKS TRÄGER MIT SCHLITTENEN SUPPORT AVEC PATINES SOPORTE CON PATINES</p>
<p>Tavola N°9 - Rev. 4 _____ 17</p> <p>ASSIEME GENERALE MAIN ASSEMBLY GENERALSATZ ASSEMBLAGE GENERAL JUNTO GENERAL</p>	<p>Tavola N°20 - Rev. 2 _____ 752290270..... 28</p> <p>GRUPPO BRACCIO ORIZZONTALE HORIZONTAL ARM UNIT HORIZONTALARMSATZ GROUPE BRAS HORIZONTAL GRUPO BRAZO HORIZONTAL</p>
<p>Tavola N°10 - Rev. 3 _____ 752292000..... 18</p> <p>ASSIEME BRACCIO MANDRINO MANDREL ARM ASSEMBLY SPINDELSARMENSEMBLE ASSEMBLAGE BRAS MANDRIN ENSEMBLADO BRAZO MANDRIL</p>	<p>Tavola N°21 - Rev. 2 _____ 752291980..... 29</p> <p>GRUPPO CARRO UTENSILI TOOLS CARRIAGE UNIT WERKZEUGSWAGENSATZ GROUPE CHARIOT OUTILS GRUPO CARRO UTENSILIOS</p>
<p>Tavola N°11 - Rev. 1 _____ 752291820..... 19</p> <p>GRUPPO MOTORE ELETTRICO ELECTRIC MOTOR UNIT ELEKTRISCHER MOTORSATZ GROUPE MOTEUR ÉLECTRIQUE GRUPO MOTOR ELÉCTRICO</p>	<p>Tavola N°22 - Rev. 2 _____ 146590063..... 30</p> <p>GRUPPO UTENSILE DOPPIO DOUBLE TOOL UNIT DOPPELWERKZEUGSATZ GROUPE OUTIL DOUBLE GRUPO UTENSILIO DOBLE</p>



RAVAGLIOLI S.p.A.

**LISTA DEI COMPONENTI
LIST OF COMPONENTS
TEILELISTE
LISTE DES PIÈCES DÉTACHÉES
LISTA DE PIEZAS**

Pag. 3 di 76

G9256.11SL - G9256.11ST - G9256.15
G9256T.15 - G9256A.15 - G9256D.15
G9256TD.15 - G9256.15SL
G10360.15 - G10360T.15 - G10360A.15
G10360D.15 - G10360TD.15

7522-R001-12_R

Tavola N°23 - Rev. 8 __ 752291800..... 31

GRUPPO CARRO UTENSILI
TOOLS CARRIAGE UNIT
WERKZEUGSWAGENSATZ
GROUPE CHARIOT OUTILES
GRUPO CARRO UTENSILIOS

Tavola N°24 - Rev. 2 __ 752290890..... 32

GRUPPO UTENSILI
TOOLS UNIT
WERKZEUGSATZ
GROUPE OUTILES
GRUPO UTENSILIOS

Tavola N°25 - Rev. 6 __ 752291811..... 33

GRUPPO ASTUCCIO CON BOCCOLE
CASE UNIT WITH BUSHING
KASTENSATZ MIT BUCHSE
GROUPE ÉTUI AVEC DOUILLE
GRUPO ESTUCHE CON CASQUILLO

Tavola N°26 - Rev. 2 __ 752291300..... 34

GRUPPO CARRO ASTUCCIO MANUALE
MANUAL CASE CARRIAGE UNIT
HANDSATZ DES WAGENKASTENS
GROUPE CHARIOT ÉTUI MANUEL
GRUPO CARRO ESTUCHE MANUAL

Tavola N°27 - Rev. 0 __ 752291311..... 35

GRUPPO ASTUCCIO MANUALE
MANUAL CASE UNIT
HANDKASTENSATZ
GROUPE ÉTUI MANUEL
GRUPO ESTUCHE MANUAL

Tavola N°28 - Rev. 2 __ 752290221..... 36

GRUPPO UTENSILI
TOOLS UNIT
WERKZEUGSATZ
GROUPE OUTILES
GRUPO UTENSILIOS

Tavola N°29 - Rev. 6 __ 752290090..... 37

CARRO
CARRIAGE
WAGEN
CHARIOT
CARRO

Tavola N°30 - Rev. 4 __ 752290552..... 38

STALLONATORE
BEAD BREAKER
ABDRÜCKER
DÉCOLLE-TALON
DESTALONADOR

Tavola N°31 - Rev. 2 __ 752292010..... 39

CENTRALINA COMPLETA
COMPLETE HYDRAULIC POWER UNIT
KOMPLETTER STEUERUNG
DISTRIBUTEUR COMPLÈTE
CENTRALITA COMPLETA

Tavola N°32 - Rev. 5 __ 752290510..... 40

CENTRALINA COMPLETA
COMPLETE HYDRAULIC POWER UNIT
KOMPLETTER STEUERUNG
DISTRIBUTEUR COMPLÈTE
CENTRALITA COMPLETA

Tavola N°33 - Rev. 2 __ 752291320..... 41

CENTRALINA COMPLETA
COMPLETE HYDRAULIC POWER UNIT
KOMPLETTER STEUERUNG
DISTRIBUTEUR COMPLÈTE
CENTRALITA COMPLETA

Tavola N°34 - Rev. 2 __ 752203210..... 42

MTG CASSETTA ELETTRICA
ELECTRIC BOX MTG
MTG ELEKTRISCHEKISTE
MTG BOITER ELECTRIQUE
MTG CAJITA ELECTRICA

Tavola N°35 - Rev. 2 __ 752203220..... 43

MTG CASSETTA ELETTRICA
ELECTRIC BOX MTG
MTG ELEKTRISCHEKISTE
MTG BOITER ELECTRIQUE
MTG CAJITA ELECTRICA

Tavola N°36 - Rev. 3 __ 752203230..... 44

MTG CASSETTA ELETTRICA
ELECTRIC BOX MTG
MTG ELEKTRISCHEKISTE
MTG BOITER ELECTRIQUE
MTG CAJITA ELECTRICA

Tavola N°37 - Rev. 2 __ 752203110..... 45

MTG CASSETTA ELETTRICA
ELECTRIC BOX MTG
MTG ELEKTRISCHEKISTE
MTG BOITER ELECTRIQUE
MTG CAJITA ELECTRICA

Tavola N°38 - Rev. 2 __ 752203250..... 46

MTG CASSETTA ELETTRICHE
MTG ELECTRICAL BOXES
ELEKTRISCHEKISTEN MTG
BOÎTES ÉLECTRIQUES MTG
CAJITAS ELÉCTRICAS MTG

Tavola N°39 - Rev. 1 __ 752203161..... 47

MTG CASSETTA ELETTRICA
ELECTRICAL BOX MTG
MTG ELEKTRISCHEKISTE
MTG BOITER ÉLECTRIQUE
MTG CAJITA ELECTRICA

Tavola N°40 - Rev. 0 __ 752203140..... 48

INSIEME MTG CASSETTA ELETTRICA
ELECTRICAL BOX MTG ASSEMBLY
SATZ MTG ELEKTRISCHEKISTE
ASSEMBLAGE MTG BOITER ÉLECTRIQUE
CONJUNTO MTG CAJITA ELECTRICA

Tavola N°41 - Rev. 2 __ 752293230..... 49

GRUPPO MANIPOLATORE
HANDLE UNIT
MANIPULATORSATZ
GROUPE MANIPULATEUR
GRUPO MANIPULADOR

Tavola N°42 - Rev. 6 __ 752293220..... 50

GRUPPO MANIPOLATORE
HANDLE UNIT
MANIPULATORSATZ
GROUPE MANIPULATEUR
GRUPO MANIPULADOR

Tavola N°43 - Rev. 4 __ 752293240..... 51

GRUPPO MANIPOLATORE
HANDLE UNIT
MANIPULATORSATZ
GROUPE MANIPULATEUR
GRUPO MANIPULADOR

Tavola N°44 - Rev. 0 __ 752292150..... 52

MANIPOLATORE IN ARIA
AIR HANDLE
MANIPULATOR IN DER LUFT
MANIPULATEUR EN AIR
MANIPULADOR EN AIRE



RAVAGLIOLI S.p.A.

**LISTA DEI COMPONENTI
LIST OF COMPONENTS
TEILELISTE
LISTE DES PIÈCES DÉTACHÉES
LISTA DE PIEZAS**

Pag. 4 di 76

G9256.11SL - G9256.11ST - G9256.15
G9256T.15 - G9256A.15 - G9256D.15
G9256TD.15 - G9256.15SL
G10360.15 - G10360T.15 - G10360A.15
G10360D.15 - G10360TD.15

7522-R001-12_R

Tavola N°45 - Rev. 0 __ 752291360..... 53

MANIPOLATORE IN ARIA
AIR HANDLE
MANIPULATOR IN DER LUFT
MANIPULATEUR EN AIR
MANIPULADOR EN AIRE

Tavola N°46 - Rev. 0 __ 752292690..... 54

MANIPOLATORE IN ARIA
AIR HANDLE
MANIPULATOR IN DER LUFT
MANIPULATEUR EN AIR
MANIPULADOR EN AIRE

Tavola N°47 - Rev. 1 __ 752290690..... 55

CILINDRO D.60
D.60 CYLINDER
ZYLINDER D.60
CYLINDRE D.60
CILINDRO D.60

Tavola N°48 - Rev. 0 __ 752290410..... 56

CILINDRO D.60
D.60 CYLINDER
ZYLINDER D.60
CYLINDRE D.60
CILINDRO D.60

Tavola N°49 - Rev. 1 __ 752290870..... 57

CILINDRO D.60
D.60 CYLINDER
ZYLINDER D.60
CYLINDRE D.60
CILINDRO D.60

Tavola N°50 - Rev. 0 __ 752290530..... 58

CILINDRO CARRO
CARRIAGE CYLINDER
WAGENZYLINDER
CYLINDRE CHARIOT
CILINDRO CARRO

Tavola N°51 - Rev. 2 __ 752290710..... 59

CILINDRO IDRAULICO D.70
D.70 HYDRAULIC CYLINDER
HYDRAULIKZYLINDER D.70
CYLINDRE HYDRAULIQUE D.70
CILINDRO HIDRÁULICO D.70

Tavola N°52 - Rev. 2 __ 752290700..... 60

CILINDRO D.70
D.70 CYLINDER
ZYLINDER D.70
CYLINDRE D.70
CILINDRO D.70

Tavola N°53 - Rev. 1 __ 752292120..... 61

BRACCIO MANDRINO INVERTER
INVERTER MANDREL ARM
SPINDELSARM VON FREQUENUMFORMER
BRAS MANDRIN VARIATEUR
BRAZO MANDRIL INVERSOR

Tavola N°54 - Rev. 0 __ 752292130..... 62

GRUPPO MOTORE ELETTRICO
ELECTRIC MOTOR UNIT
ELEKTRISCHER MOTORSATZ
GROUPE MOTEUR ÉLECTRIQUE
GRUPO MOTOR ELÉCTRICO

Tavola N°55 - Rev. 1 __ 752292140..... 63

BRACCIO MANDRINO INVERTER
INVERTER MANDREL ARM
SPINDELSARM VON FREQUENUMFORMER
BRAS MANDRIN VARIATEUR
BRAZO MANDRIL INVERSOR

Tavola N°56 - Rev. 0 __ 752292100..... 64

GRUPPO INVERTER
INVERTER UNIT
FREQUENUMFORMERSATZ
GROUPE VARIATEUR
GRUPO INVERSOR

Tavola N°57 - Rev. 0 __ 752292070..... 65

GRUPPO INVERTER
INVERTER UNIT
FREQUENUMFORMERSATZ
GROUPE VARIATEUR
GRUPO INVERSOR

Tavola N°58 - Rev. 0 __ 752292190..... 66

CILINDRO D.60
D.60 CYLINDER
ZYLINDER D.60
CYLINDRE D.60
CILINDRO D.60

Tavola N°59 - Rev. 0 __ 752292290..... 67

GRUPPO UTENSILI SENZA LEVA
TOOLS UNIT WITHOUT LEVER
WERKZEUGSATZ OHNE HEBEL
GROUPE OUTILES SANS LEVIER
GRUPO UTENSILIOS SINE PALANCA

Tavola N°60 - Rev. 0 __ 752292340..... 68

GRUPPO UTENSILI SENZA LEVA
TOOLS UNIT WITHOUT LEVER
WERKZEUGSATZ OHNE HEBEL
GROUPE OUTILES SANS LEVIER
GRUPO UTENSILIOS SINE PALANCA

Tavola N°61 - Rev. 0 __ 752292610..... 69

CENTRALINA COMPLETA
COMPLETE HYDRAULIC POWER UNIT
KOMPLETTER STEUERUNG
DISTRIBUTEUR COMPLÈTE
CENTRALITA COMPLETA

Tavola N°62 - Rev. 0 __ 752203180..... 70

MTG CASSETTA ELETTRICA
ELECTRICAL BOX MTG
MTG ELEKTRISCHEKISTE
MTG BOÏTER ÉLECTRIQUE
MTG CAJITA ELECTRICA

Tavola N°63 - Rev. 0 __ 752293060..... 71

GRUPPO INVERTER
INVERTER UNIT
FREQUENUMFORMERSATZ
GROUPE VARIATEUR
GRUPO INVERSOR

Tavola N°64 - Rev. 0 __ 752291171..... 72

MANIPOLATORE
HANDLE
MANIPULATOR
MANIPULATEUR
MANIPULADOR

Tavola N°65 - Rev. 0 __ 752203061..... 73

INSIEME MTG CASSETTA ELETTRICA
ELECTRIC BOX MTG ASSEMBLY
ENSEMBLE MTG ELEKTRISCHEKISTE
ASSEMBLAGE MTG BOÏTER ELECTRIQUE
JUNTO MTG CAJITA ELECTRICA

Tavola N°66 - Rev. 0 __ 752203092..... 74

CASSETTA ELETTRICA
ELECTRICAL BOX
ELEKTRISCHEKISTE
BOÏTER ÉLECTRIQUE
CAJITA ELECTRICA



RAVAGLIOLI S.p.A.

**LISTA DEI COMPONENTI
LIST OF COMPONENTS
TEILELISTE
LISTE DES PIÈCES DÉTACHÉES
LISTA DE PIEZAS**

Pag. 5 di 76

G9256.11SL - G9256.11ST - G9256.15
G9256T.15 - G9256A.15 - G9256D.15
G9256TD.15 - G9256.15SL
G10360.15 - G10360T.15 - G10360A.15
G10360D.15 - G10360TD.15

7522-R001-12_R

Tavola N°67 - Rev. 0__ 752293080..... 75

GRUPPO BRACCIO MANDRINO
MANDREL ARM UNIT
SPINDELARMSATZ
GROUPE BRAS MANDRIN
GRUPO BRAZO MANDRIL

Tavola N°68 - Rev. 0__ 752203170..... 76

MTG CASSETTA ELETTRICA
ELECTRICAL BOX MTG
MTG ELEKTRISCHEKISTE
MTG BOITER ÉLECTRIQUE
MTG CAJITA ELECTRICA



RAVAGLIOLI S.p.A.

**LISTA DEI COMPONENTI - LIST OF COMPONENTS - TEILELISTE
LISTE DES PIECES DETACHEES - LISTA DE PIEZAS**

Rev. 4

ELENCO GRUPPI MACCHINA
MACHINE UNITS LIST
MASCHINEGRUPPENLISTE
LISTE DES GROUPES MACHINE
LISTA DE GRUPOS MÁQUINA

Pag. 6 di 76

G9256.11SL - G9256.11ST - G9256.15 - G9256T.15
G9256A.15 - G9256D.15 - G9256TD.15 - G9256.15SL
G10360.15 - G10360T.15 - G10360A.15
G10360D.15 - G10360TD.15

Tav.	Cod.	G9256.11SL	G9256.11ST	G9256.15	G9256T.15	G9256A.15	G9256D.15	G9256TD.15	G9256.15SL	G10360.15	G10360T.15	G10360A.15	G10360D.15	G10360TD.15
------	------	------------	------------	----------	-----------	-----------	-----------	------------	------------	-----------	------------	------------	------------	-------------

1	-	•												
2	-		•											
3	-			•	•									
4	-					•								
5	-								•					
6	-									•	•			
7	-											•		
8	-						•	•						
9	-												•	•
10	752292000	•	•						•					
11	752291820	•	•						•					
12	752290780	•	•	•	•	•	•	•	•					
13	752290770			•	•	•								
14	752290790			•	•	•								
15	752290170									•	•	•		
16	752290130									•	•	•	•	•
17	752290250									•	•	•	•	•
18	B9641000	•	•	•	•	•	•	•	•	•	•	•	•	•
19	752291080	•	•	•	•	•	•	•	•					
20	752290270									•	•	•	•	•
21	752291980	•							•					
22	146590063	•	•						•					
23	752291800			•	•	•	•	•						
24	752290890			•		•	•							
25	752291810			•	•	•	•	•						
26	752291300		•											
27	752291311		•											
28	752290221									•		•	•	
29	752290090									•		•	•	
30	752290551									•	•	•	•	•
31	752292010	•							•					



RAVAGLIOLI S.p.A.

**LISTA DEI COMPONENTI - LIST OF COMPONENTS - TEILELISTE
LISTE DES PIECES DETACHEES - LISTA DE PIEZAS**

Rev. 4

ELENCO GRUPPI MACCHINA
MACHINE UNITS LIST
MASCHINEGRUPPENLISTE
LISTE DES GROUPES MACHINE
LISTA DE GRUPOS MÁQUINA

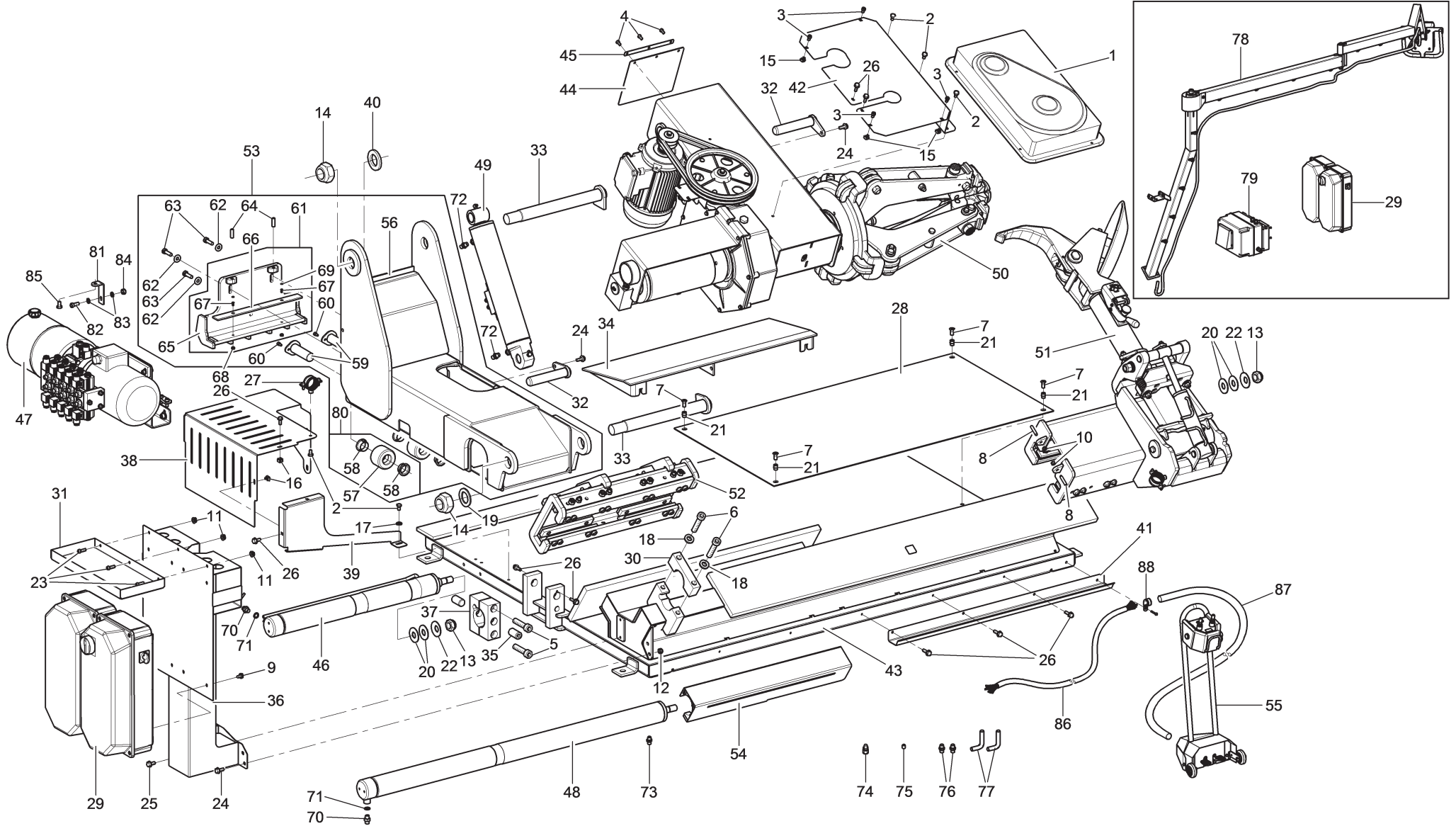
Pag. 7 di 76

G9256.11SL - G9256.11ST - G9256.15 - G9256T.15
G9256A.15 - G9256D.15 - G9256TD.15 - G9256.15SL
G10360.15 - G10360T.15 - G10360A.15
G10360D.15 - G10360TD.15

Tav.	Cod.	G9256.11SL	G9256.11ST	G9256.15	G9256T.15	G9256A.15	G9256D.15	G9256TD.15	G9256.15SL	G10360.15	G10360T.15	G10360A.15	G10360D.15	G10360TD.15
------	------	------------	------------	----------	-----------	-----------	-----------	------------	------------	-----------	------------	------------	------------	-------------

32	752290510			•	•	•	•	•						
33	752291320		•											
34	752203210	•							•					
35	752203220		•											
36	752203230			•	•					•	•			
37	752203110			VAR	VAR	•				VAR	VAR	•		
38	752203250						•	•					•	•
39	752203161	VAR							VAR					
40	752203140								VAR					
41	752293230	•							•					
42	752293220			•	•		•	•		•	•		•	•
43	752293240		•											
44	752292150			VAR	VAR	•								
45	752291360									VAR	VAR	•	VAR	VAR
46	752292690	VAR							VAR					
47	752290690	•	•											
48	752290410			•	•	•	•	•	•					
49	752290870	•	•											
50	752290530			•	•	•	•	•	•	•	•	•	•	•
51	752290710	•	•	•	•	•	•	•	•					
52	752290700									•	•	•	•	•
53	752292120						•	•	VAR					
54	752292130						•	•	VAR					
55	752292140												•	•
56	752292100						•	•						
57	752292070												•	•
58	752292190									•	•	•	•	•
59	752292290				•			•						
60	752292340										•			•
61	752292610									•	•	•	•	•
62	752203180	VAR							VAR					

VAR = VARIANTE / VERSION / VERSION / VERSION / VERSIÓN



G9256.11SL	G9256.11ST	G9256.15	G9256T.15	G9256A.15	G9256D.15	G9256TD.15	G9256.15SL	G10360.15	G10360T.15	G10360A.15	G10360D.15	G10360TD.15						
•																		

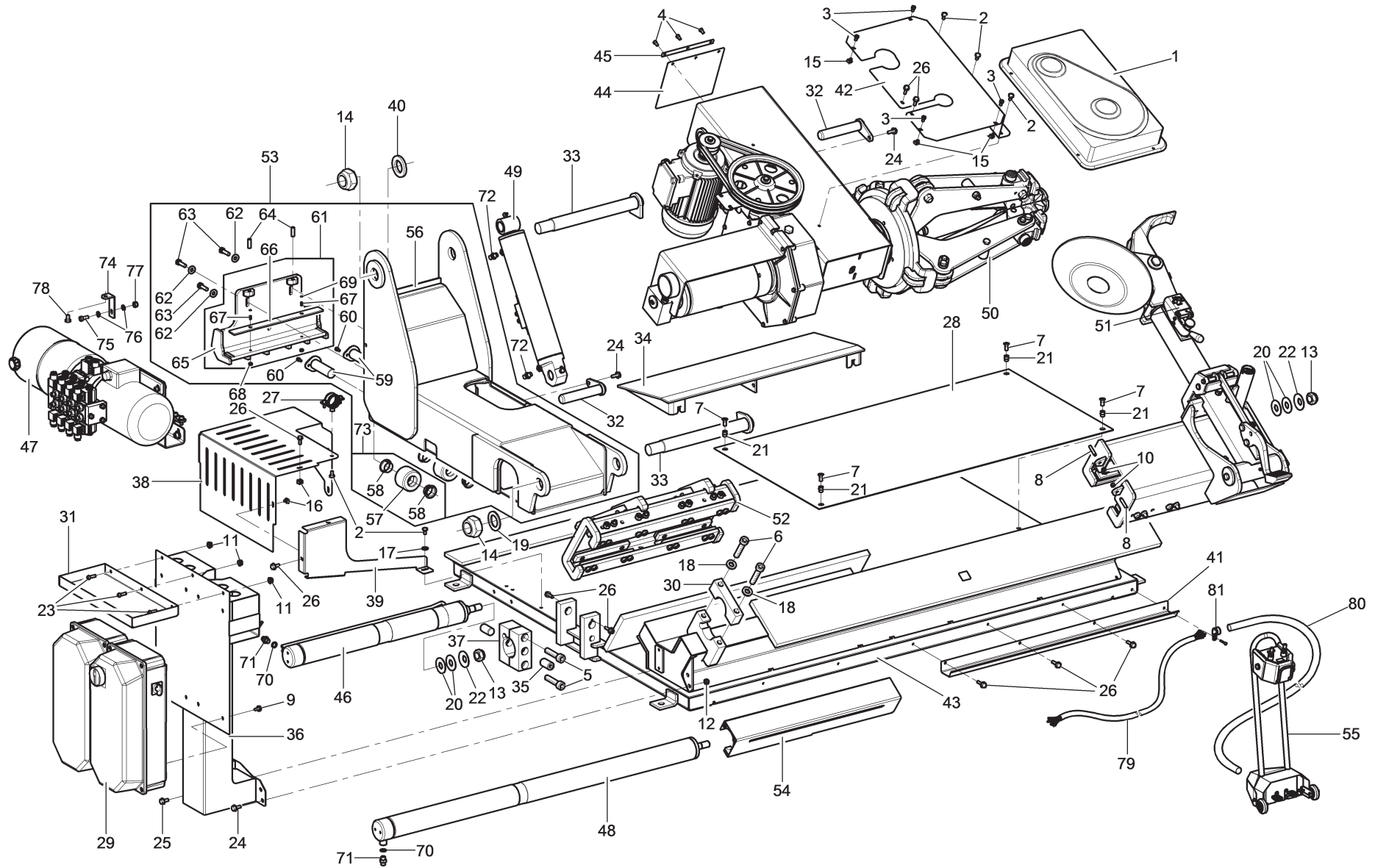



**LISTA DEI COMPONENTI - LIST OF COMPONENTS - TEILELISTE
LISTE DES PIÈCES DÉTACHÉES - LISTA DE PIEZAS**

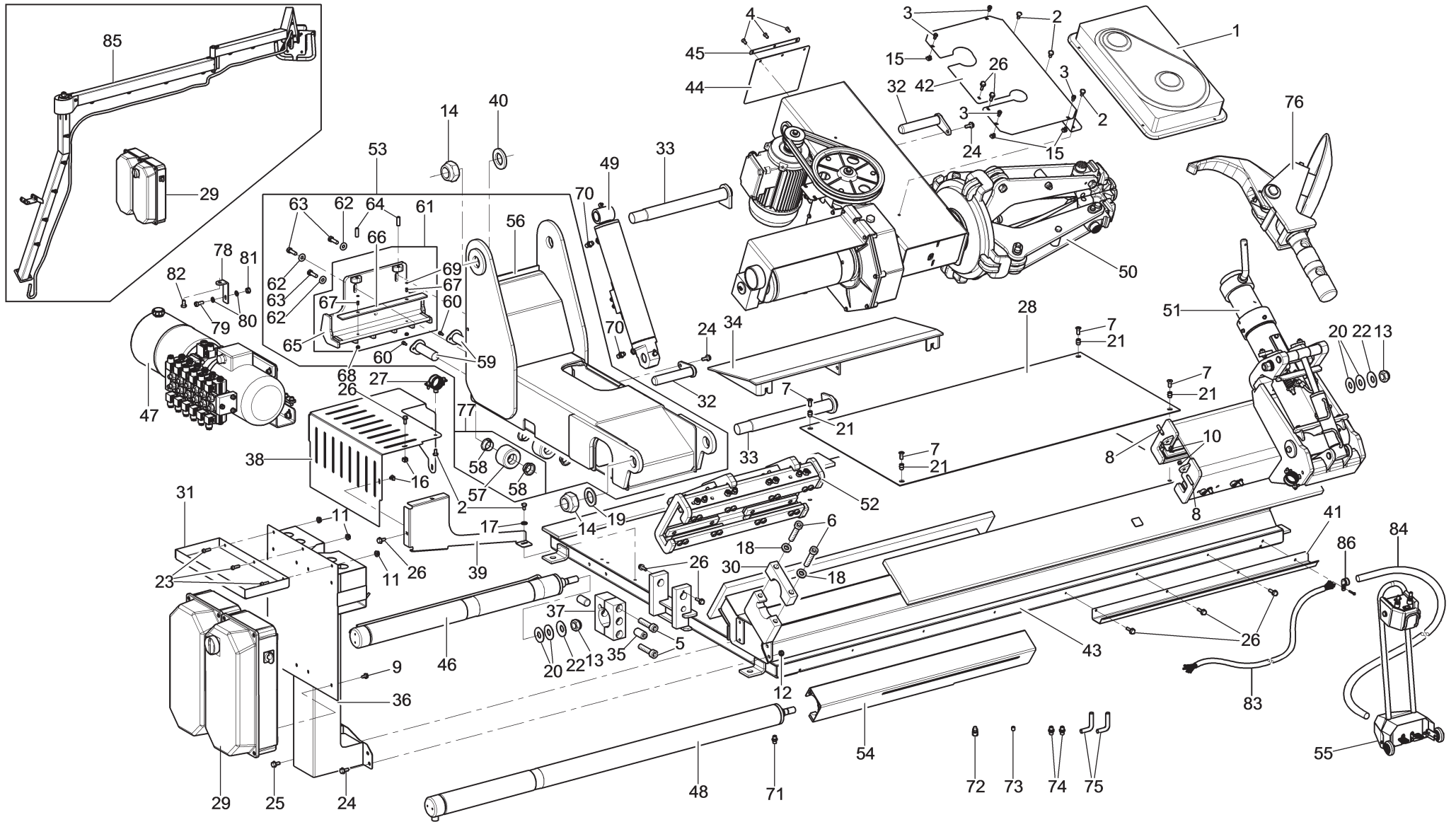
Tavola N°1 - Rev. 4


ASSIEME GENERALE
MAIN ASSEMBLY
GENERALSATZ
ASSEMBLAGE GENERAL
JUNTO GENERAL

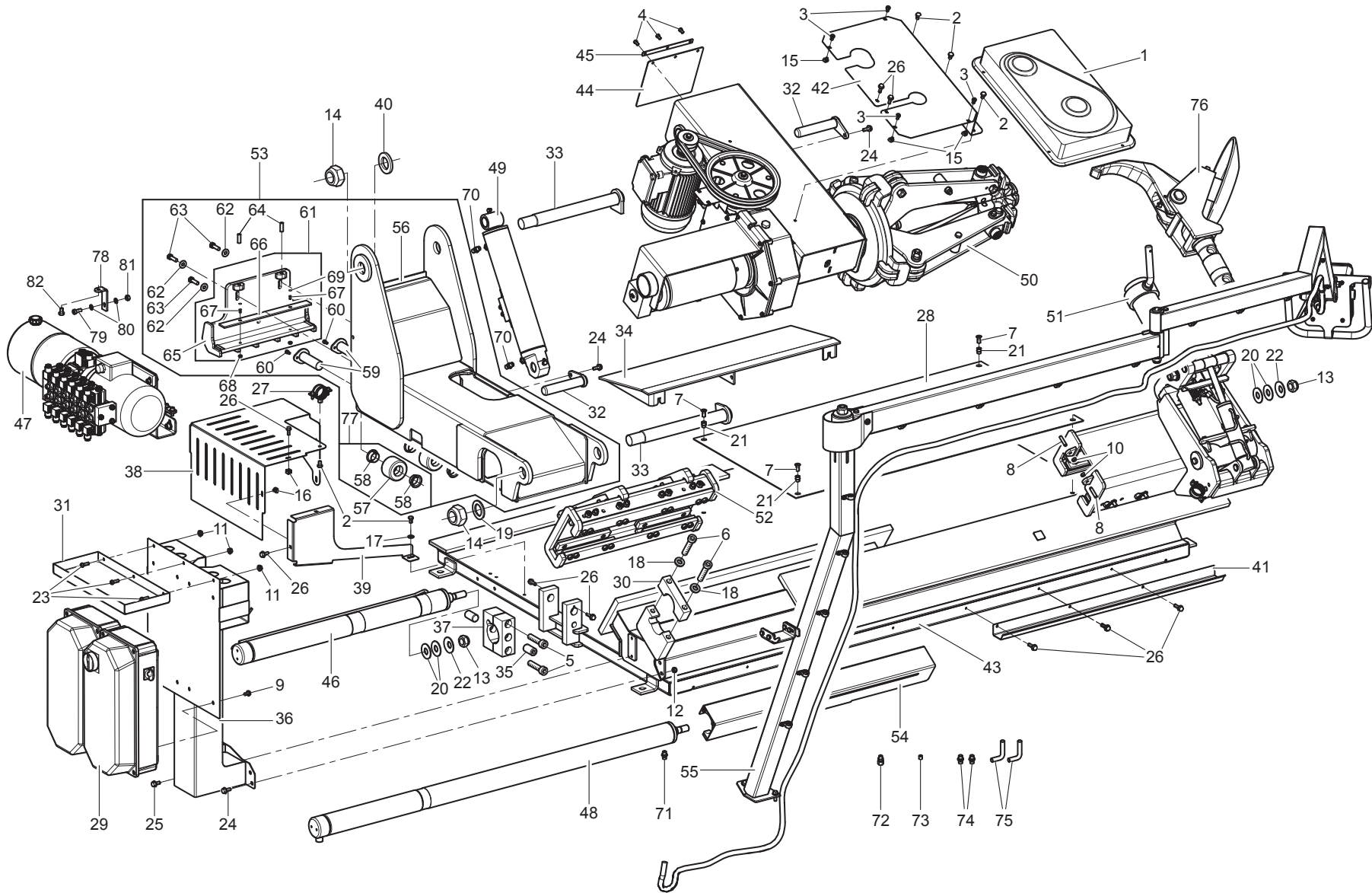
Pag. 9 di 76




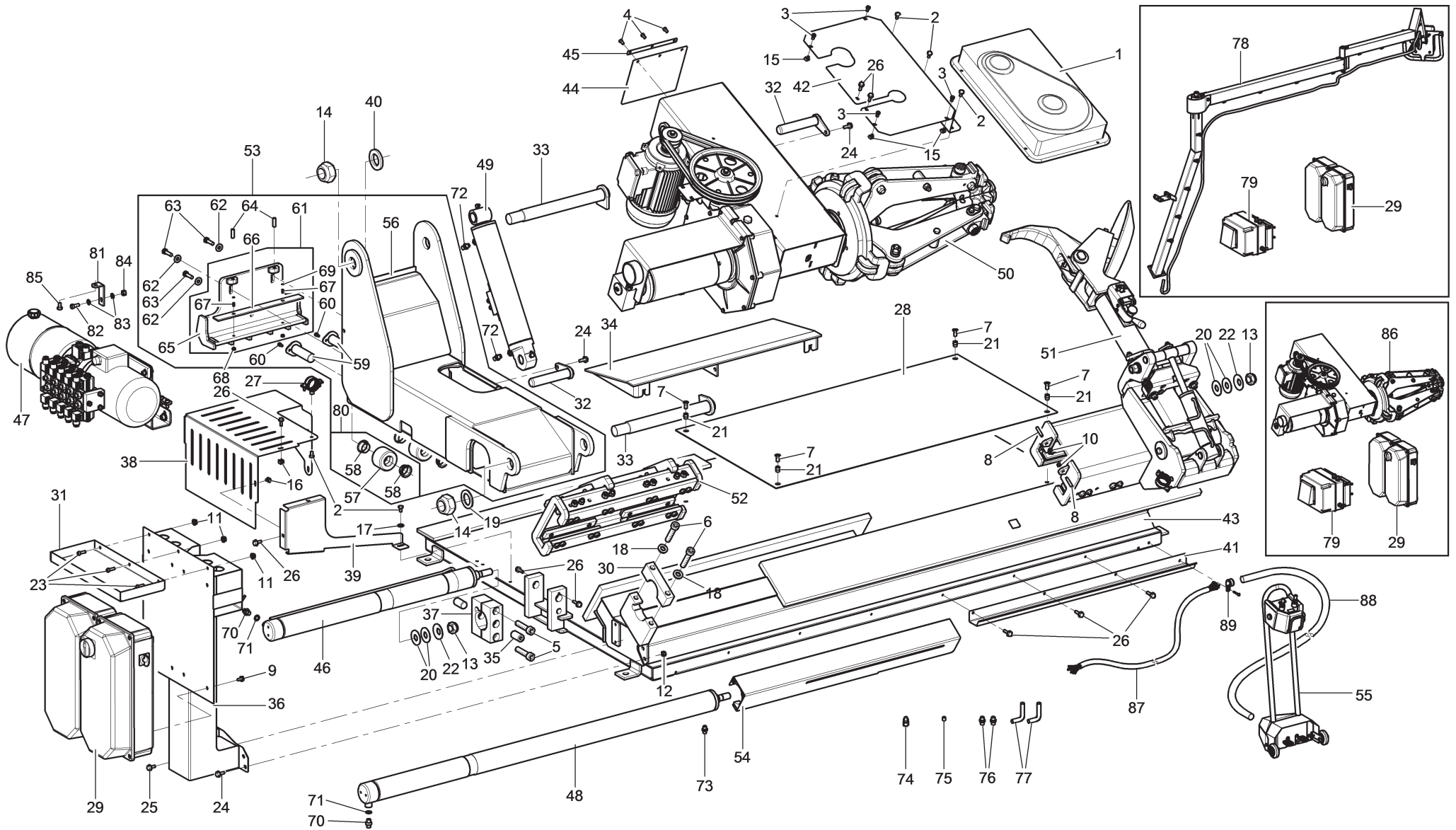
G9256.11SL	G9256.11ST	G9256.15	G9256T.15	G9256A.15	G9256D.15	G9256TD.15	G9256.15SL	G10360.15	G10360T.15	G10360A.15	G10360D.15	G10360TD.15					
	•																
 RAVAGLIOLI S.p.A.		LISTA DEI COMPONENTI - LIST OF COMPONENTS - TEILELISTE LISTE DES PIÈCES DÉTACHÉES - LISTA DE PIEZAS						ASSIEME GENERALE MAIN ASSEMBLY GENERALSATZ ASSEMBLAGE GENERAL JUNTO GENERAL					Pag. 10 di 76				
Tavola N°2 - Rev. 4																	



G9256.11SL	G9256.11ST	G9256.15	G9256T.15	G9256A.15	G9256D.15	G9256TD.15	G9256.15SL	G10360.15	G10360T.15	G10360A.15	G10360D.15	G10360TD.15						
		•	•															
 RAVAGLIOLI S.p.A.		LISTA DEI COMPONENTI - LIST OF COMPONENTS - TEILELISTE LISTE DES PIÈCES DÉTACHÉES - LISTA DE PIEZAS						ASSIEME GENERALE MAIN ASSEMBLY GENERALSATZ ASSEMBLAGE GENERAL JUNTO GENERAL					Pag. 11 di 76					
Tavola N°3 - Rev. 6																		



G9256.11SL	G9256.11ST	G9256.15	G9256T.15	G9256A.15	G9256D.15	G9256TD.15	G9256.15SL	G10360.15	G10360T.15	G10360A.15	G10360D.15	G10360TD.15						
 RAVAGLIOLI S.p.A.			LISTA DEI COMPONENTI - LIST OF COMPONENTS - TEILELISTE LISTE DES PIÈCES DÉTACHÉES - LISTA DE PIEZAS					ASSIEME GENERALE MAIN ASSEMBLY GENERALSATZ ASSEMBLAGE GENERAL JUNTO GENERAL					Pag. 12 di 76					
Tavola N°4 - Rev. 3																		



G9256.11SL	G9256.11ST	G9256.15	G9256T.15	G9256A.15	G9256D.15	G9256TD.15	G9256.15SL	G10360.15	G10360T.15	G10360A.15	G10360D.15	G10360TD.15						

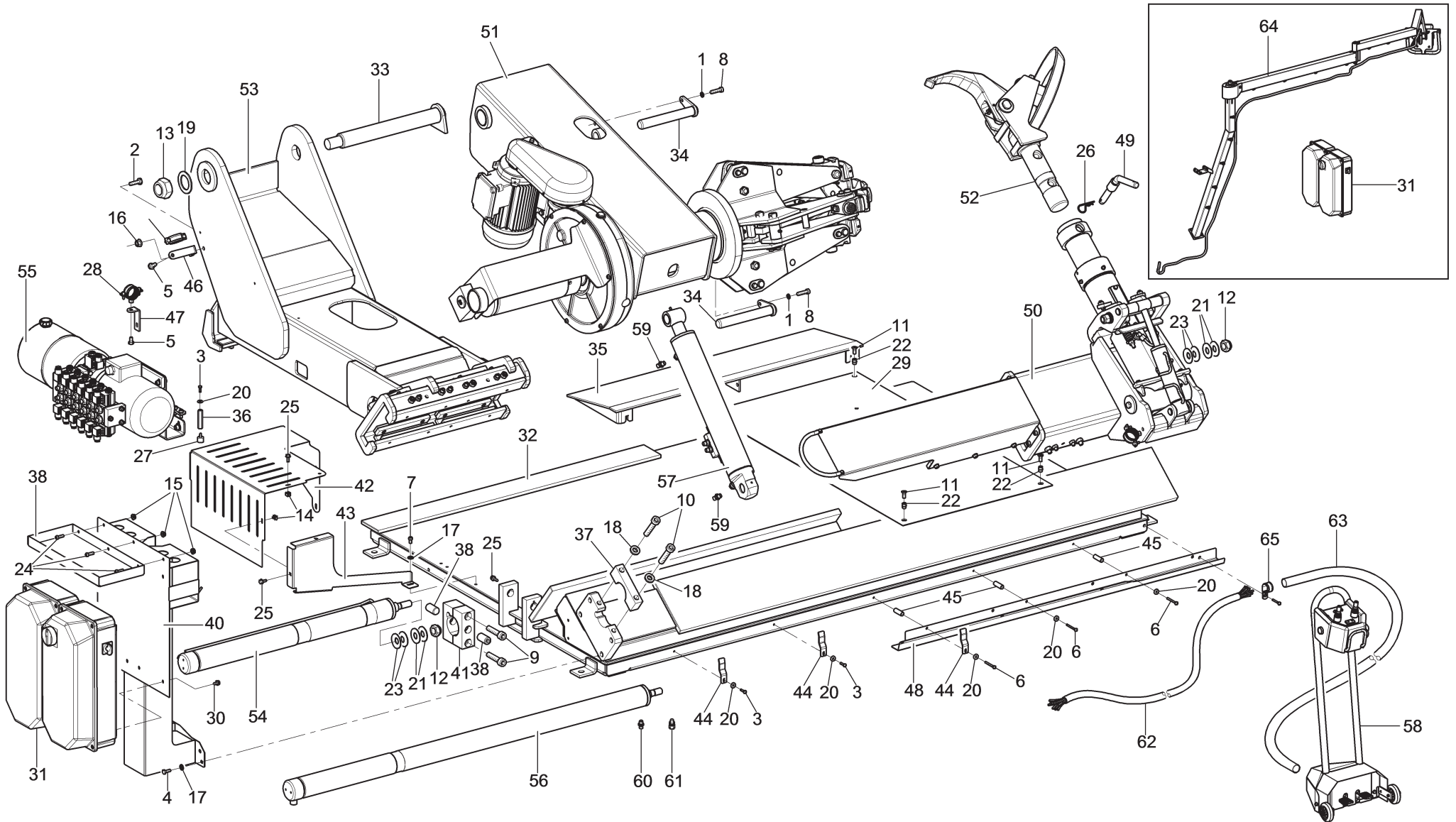


**LISTA DEI COMPONENTI - LIST OF COMPONENTS - TEILELISTE
LISTE DES PIÈCES DÉTACHÉES - LISTA DE PIEZAS**

Tavola N°5 - Rev. 4

ASSIEME GENERALE
MAIN ASSEMBLY
GENERSATZ
ASSEMBLAGE GENERAL
JUNTO GENERAL

Pag. 13 di 76



G9256.11SL	G9256.11ST	G9256.15	G9256T.15	G9256A.15	G9256D.15	G9256TD.15	G9256.15SL	G10360.15	G10360T.15	G10360A.15	G10360D.15	G10360TD.15						
								•	•									

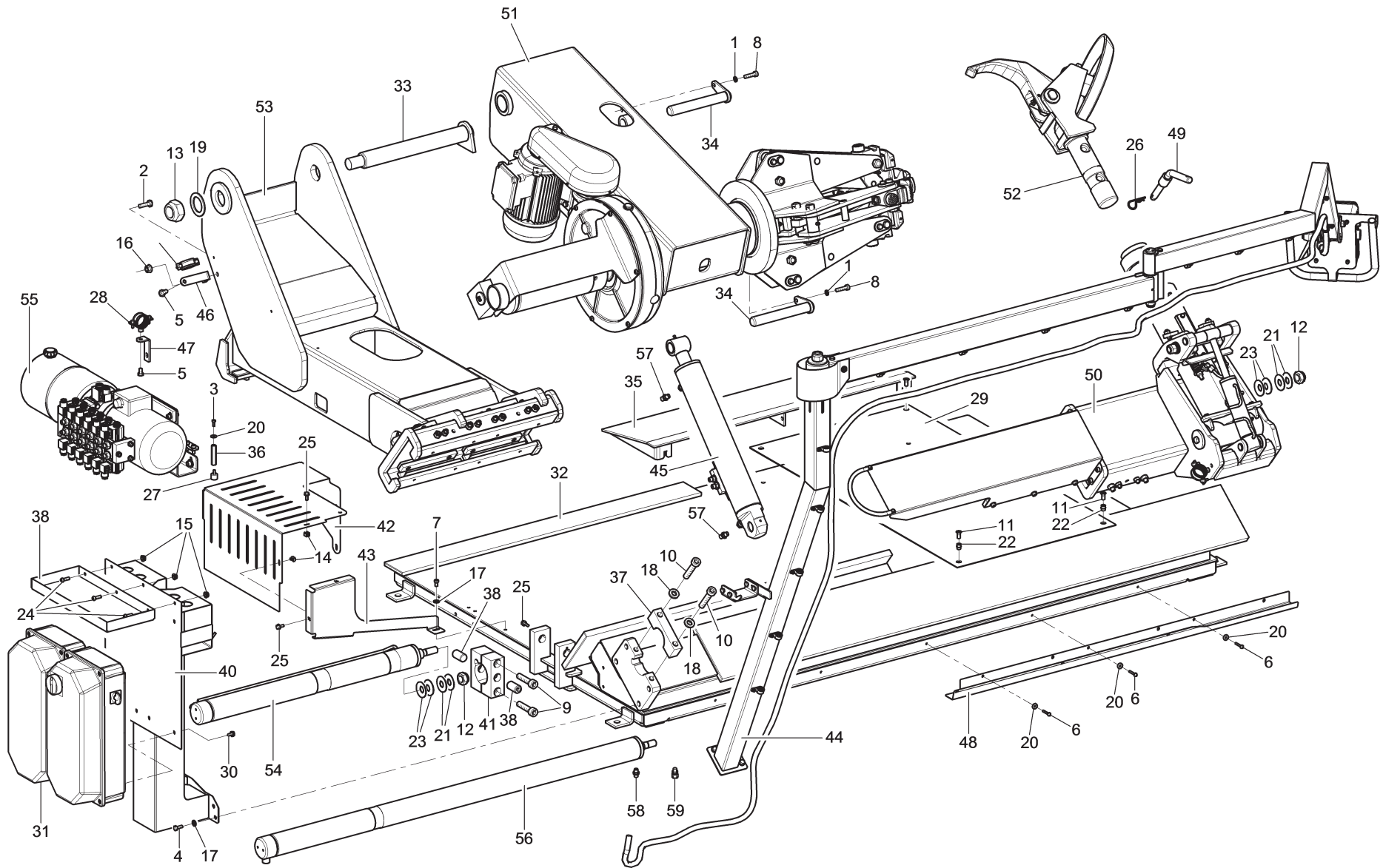



**LISTA DEI COMPONENTI - LIST OF COMPONENTS - TEILELISTE
LISTE DES PIÈCES DÉTACHÉES - LISTA DE PIEZAS**

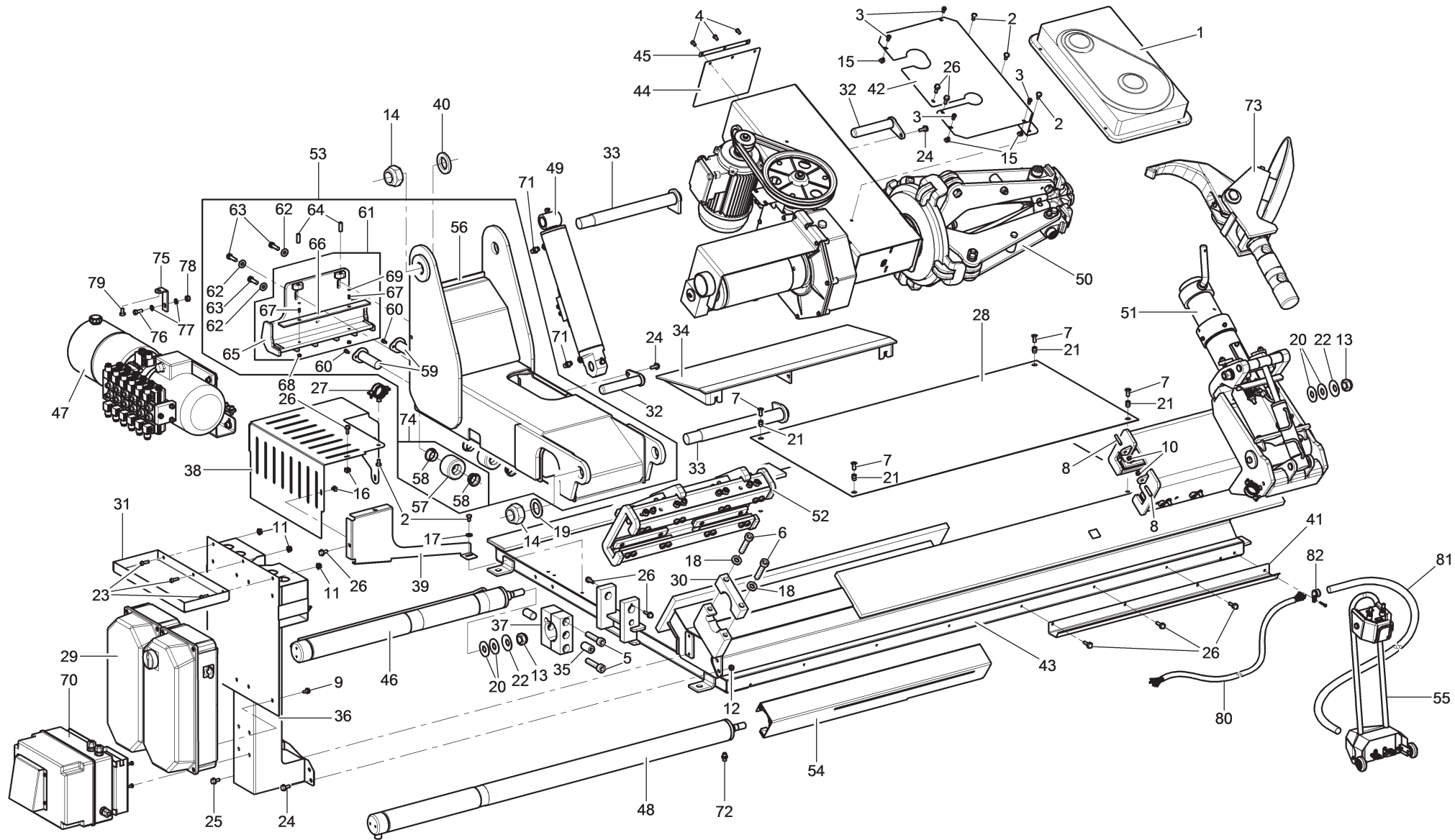
Tavola N°6 - Rev. 5


ASSIEME GENERALE
MAIN ASSEMBLY
GENERSATZ
ASSEMBLAGE GENERAL
JUNTO GENERAL

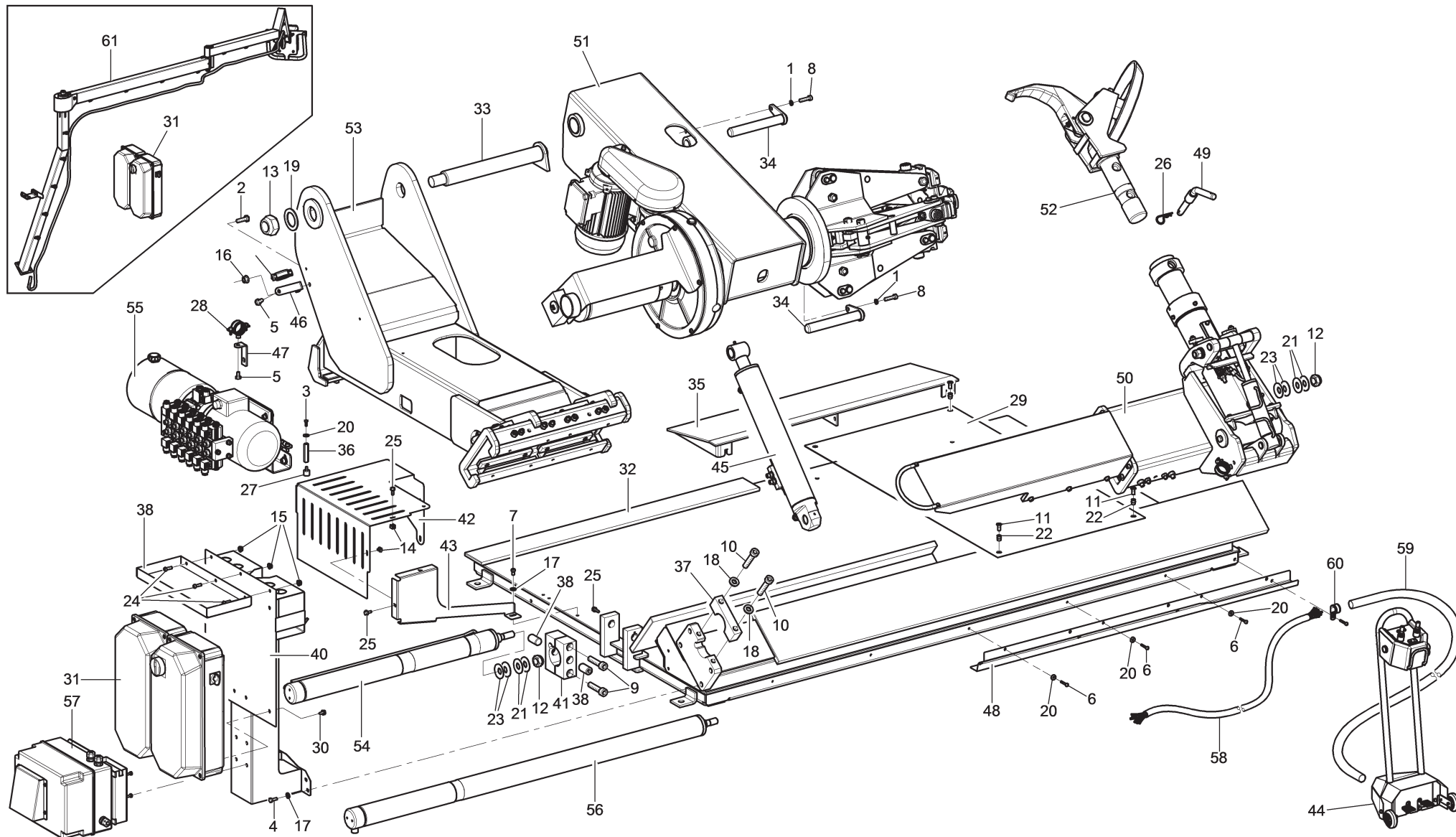
Pag. 14 di 76



G9256.11SL	G9256.11ST	G9256.15	G9256T.15	G9256A.15	G9256D.15	G9256TD.15	G9256.15SL	G10360.15	G10360T.15	G10360A.15	G10360D.15	G10360TD.15									
 RAVAGLIOLI S.p.A.										LISTA DEI COMPONENTI - LIST OF COMPONENTS - TEILELISTE LISTE DES PIÈCES DÉTACHÉES - LISTA DE PIEZAS				ASSIEME GENERALE MAIN ASSEMBLY GENERSATZ ASSEMBLAGE GENERAL JUNTO GENERAL				Pag. 15 di 76			
Tavola N°7 - Rev. 3																					



G9256.11SL	G9256.11ST	G9256.15	G9256T.15	G9256A.15	G9256D.15	G9256TD.15	G9256.15SL	G10360.15	G10360T.15	G10360A.15	G10360D.15	G10360TD.15					
					•	•											
 RAVAGLIOLI S.p.A.			LISTA DEI COMPONENTI - LIST OF COMPONENTS - TEILELISTE LISTE DES PIÈCES DÉTACHÉES - LISTA DE PIEZAS					ASSIEME GENERALE MAIN ASSEMBLY GENERALSATZ ASSEMBLAGE GENERAL JUNTO GENERAL						Pag. 16 di 76			
			Tavola N°8 - Rev. 5														



G9256.11SL	G9256.11ST	G9256.15	G9256T.15	G9256A.15	G9256D.15	G9256TD.15	G9256.15SL	G10360.15	G10360T.15	G10360A.15	G10360D.15	G10360TD.15						
											•	•						

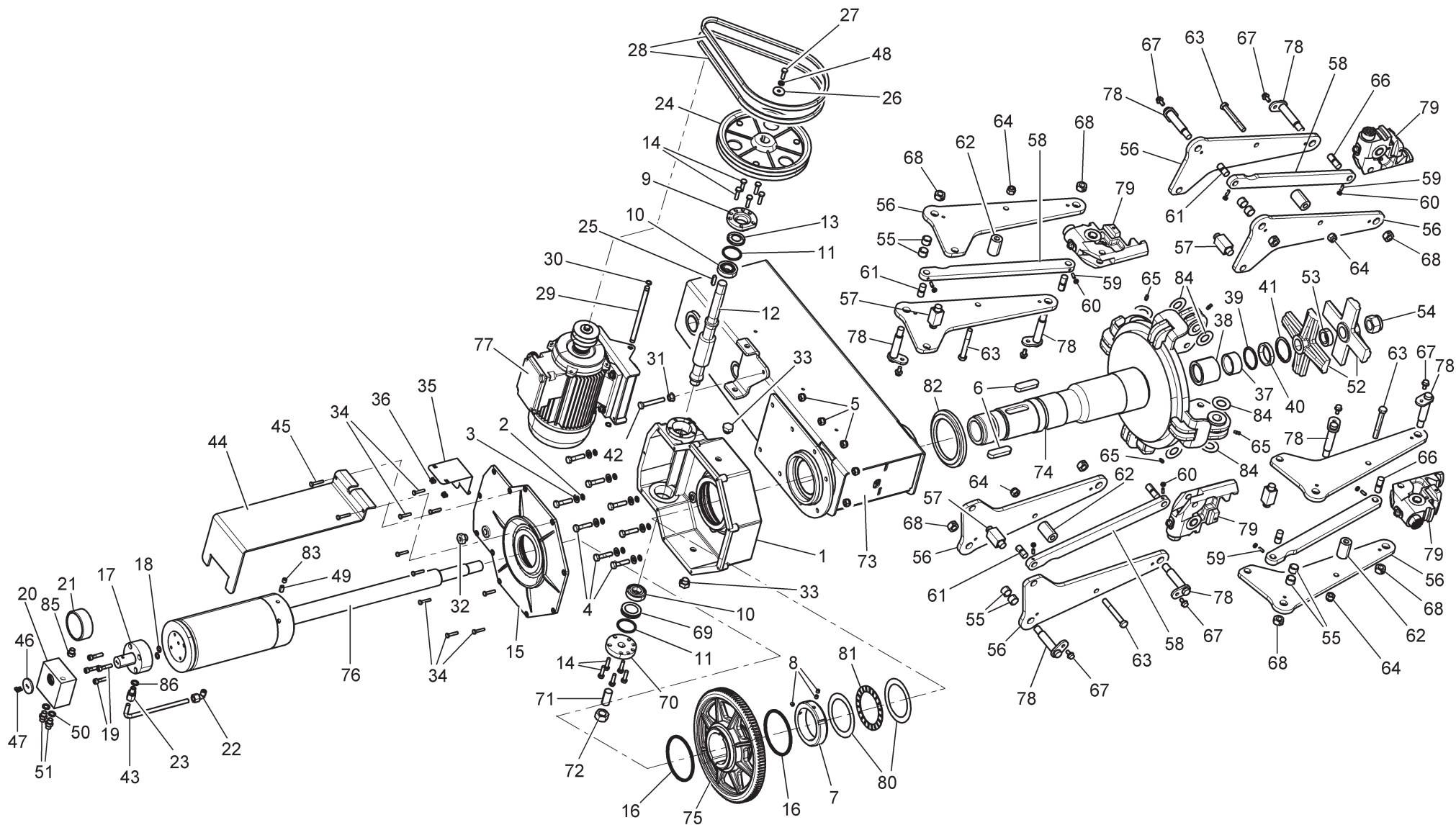


**LISTA DEI COMPONENTI - LIST OF COMPONENTS - TEILELISTE
LISTE DES PIÈCES DÉTACHÉES - LISTA DE PIEZAS**

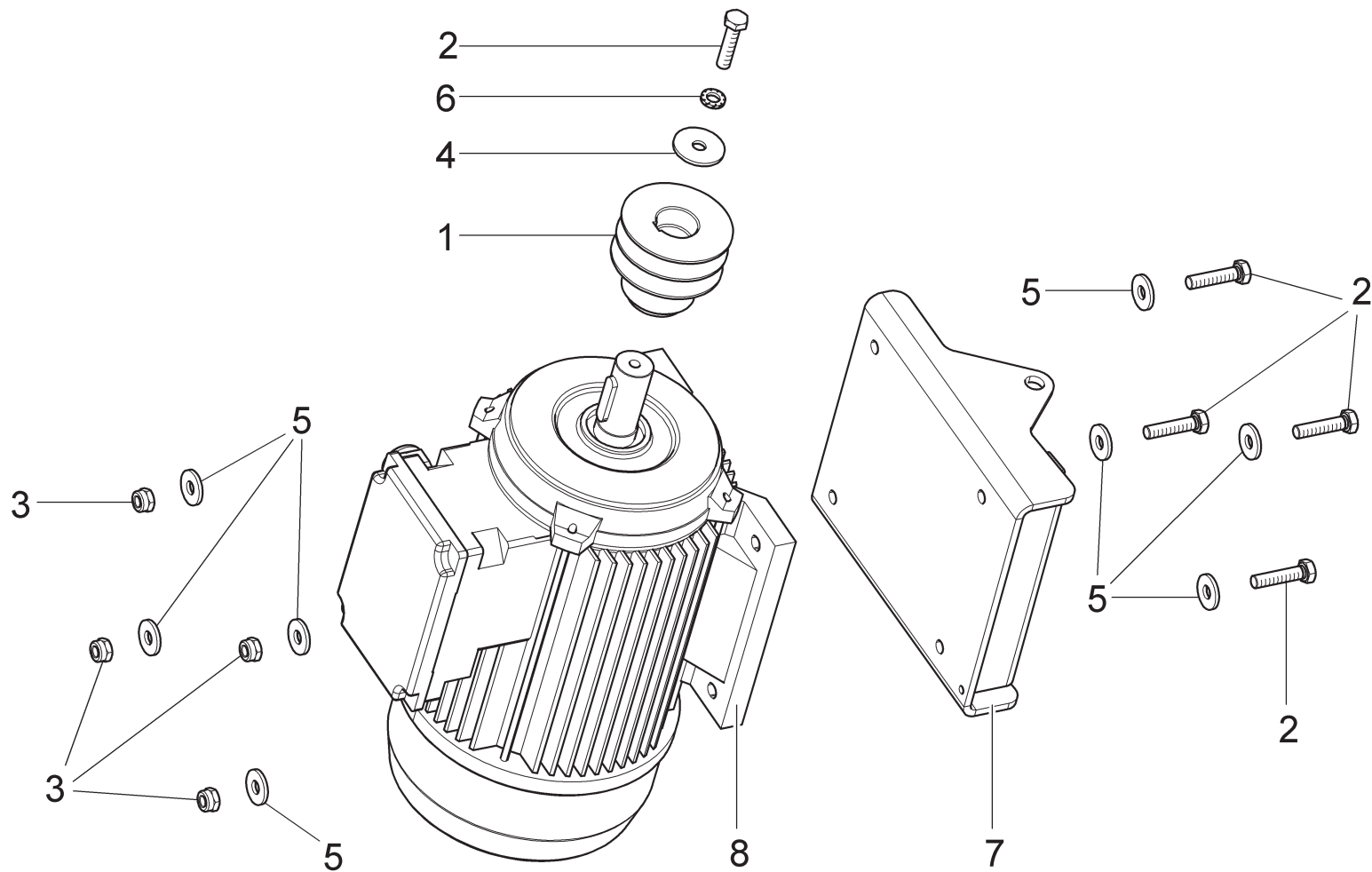
Tavola N°9 - Rev. 4

ASSIEME GENERALE
MAIN ASSEMBLY
GENERSATZ
ASSEMBLAGE GENERAL
JUNTO GENERAL

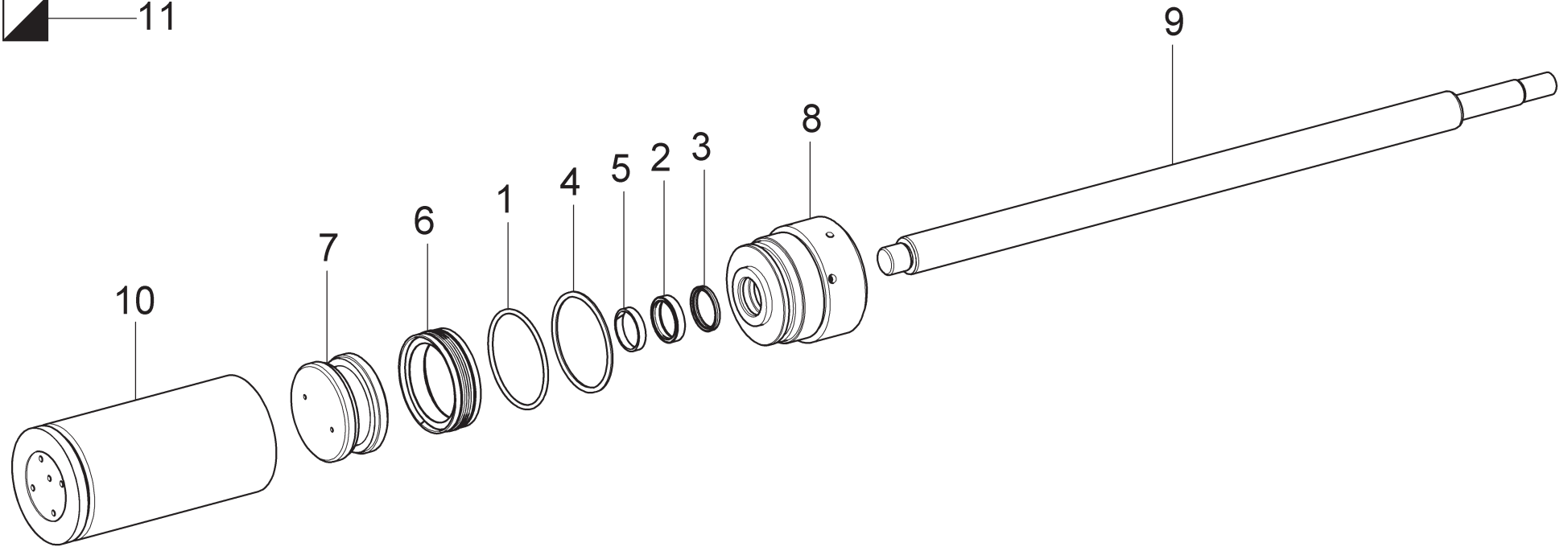
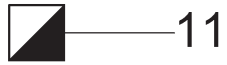
Pag. 17 di 76



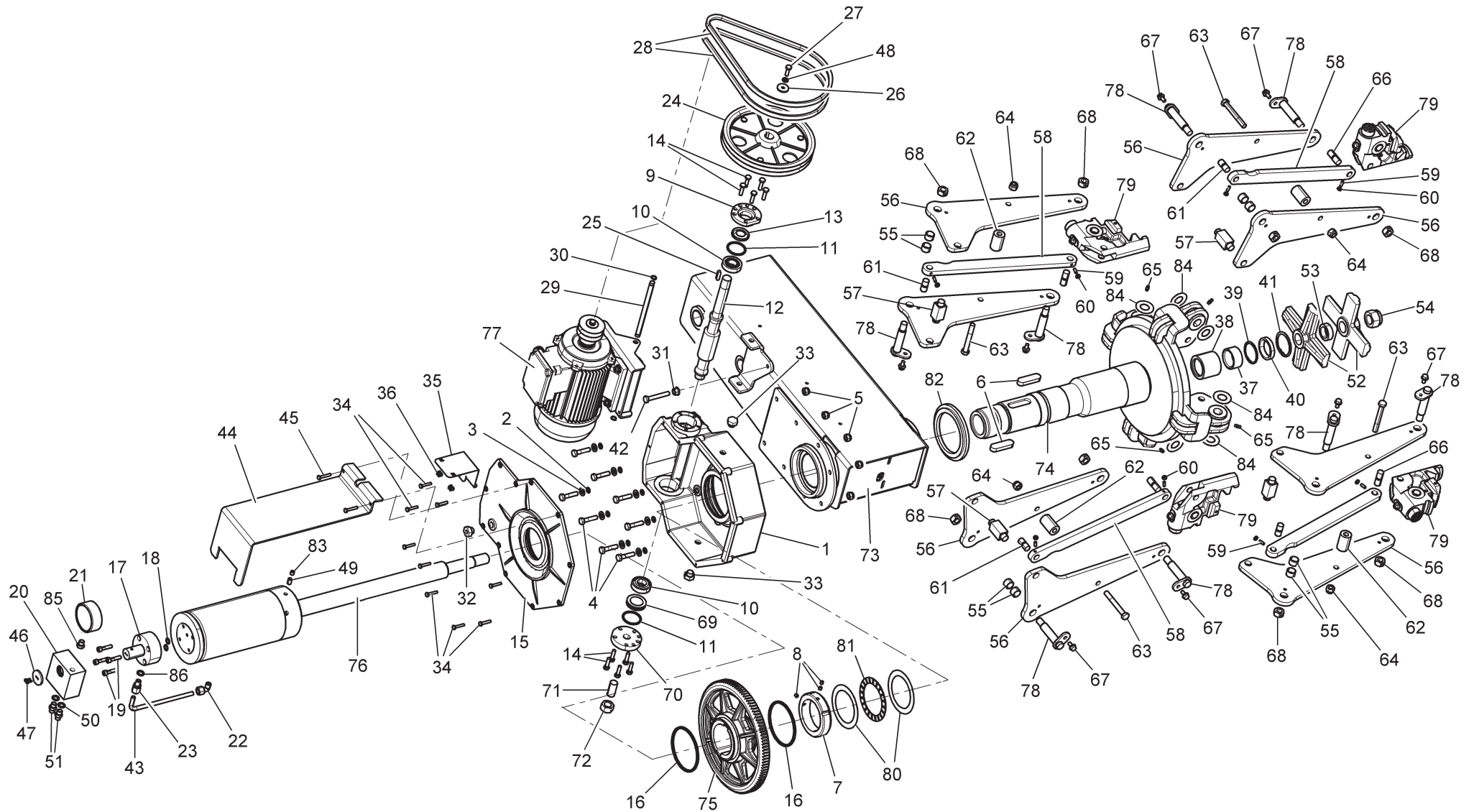
G9256.11SL	G9256.11ST	G9256.15	G9256T.15	G9256A.15	G9256D.15	G9256TD.15	G9256.15SL	G10360.15	G10360T.15	G10360A.15	G10360D.15	G10360TD.15							
•	•						•												
 RAVAGLIOLI S.p.A.		LISTA DEI COMPONENTI - LIST OF COMPONENTS - TEILELISTE LISTE DES PIÈCES DÉTACHÉES - LISTA DE PIEZAS						Tavola N°10 - Rev. 3					752292000					Pag. 18 di 76	
		ASSIEME BRACCIO MANDRINO MANDREL ARM ASSEMBLY SPINDELSARMENSEMBLE ASSEMBLAGE BRAS MANDRIN ENSEMBLADO BRAZO MANDRIL																	



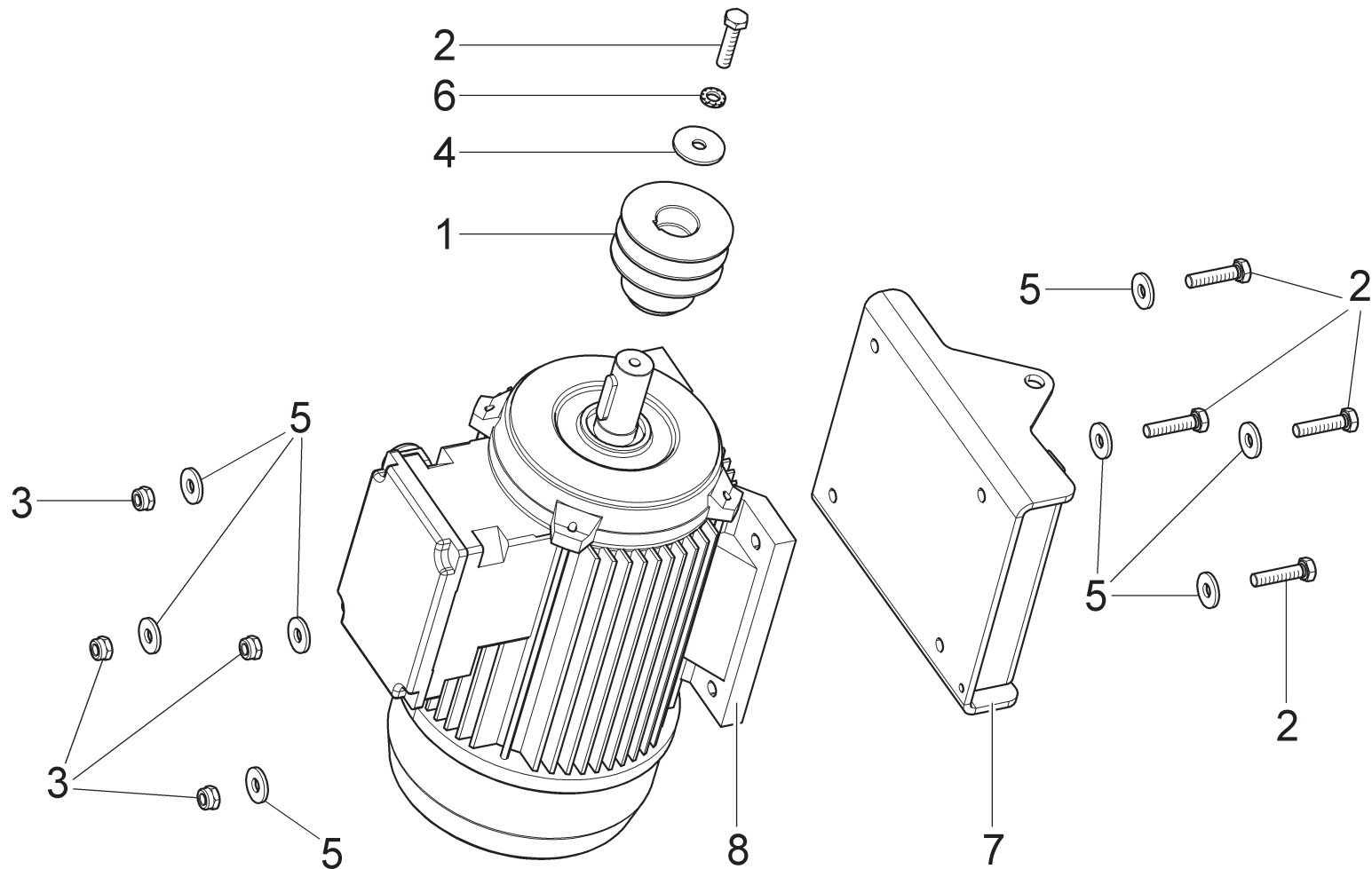
G9256.11SL	G9256.11ST	G9256.15	G9256T.15	G9256A.15	G9256D.15	G9256TD.15	G9256.15SL	G10360.15	G10360T.15	G10360A.15	G10360D.15	G10360TD.15				
•	•						•									
 RAVAGLIOLI S.p.A.		LISTA DEI COMPONENTI - LIST OF COMPONENTS - TEILELISTE LISTE DES PIÈCES DÉTACHÉES - LISTA DE PIEZAS						GRUPPO MOTORE ELETTRICO ELECTRIC MOTOR UNIT ELEKTRISCHER MOTORSATZ GROUPE MOTEUR ÉLECTRIQUE GRUPO MOTOR ELÉCTRICO					Pag. 19 di 76			
		Tavola N°11 - Rev. 1			752291820											



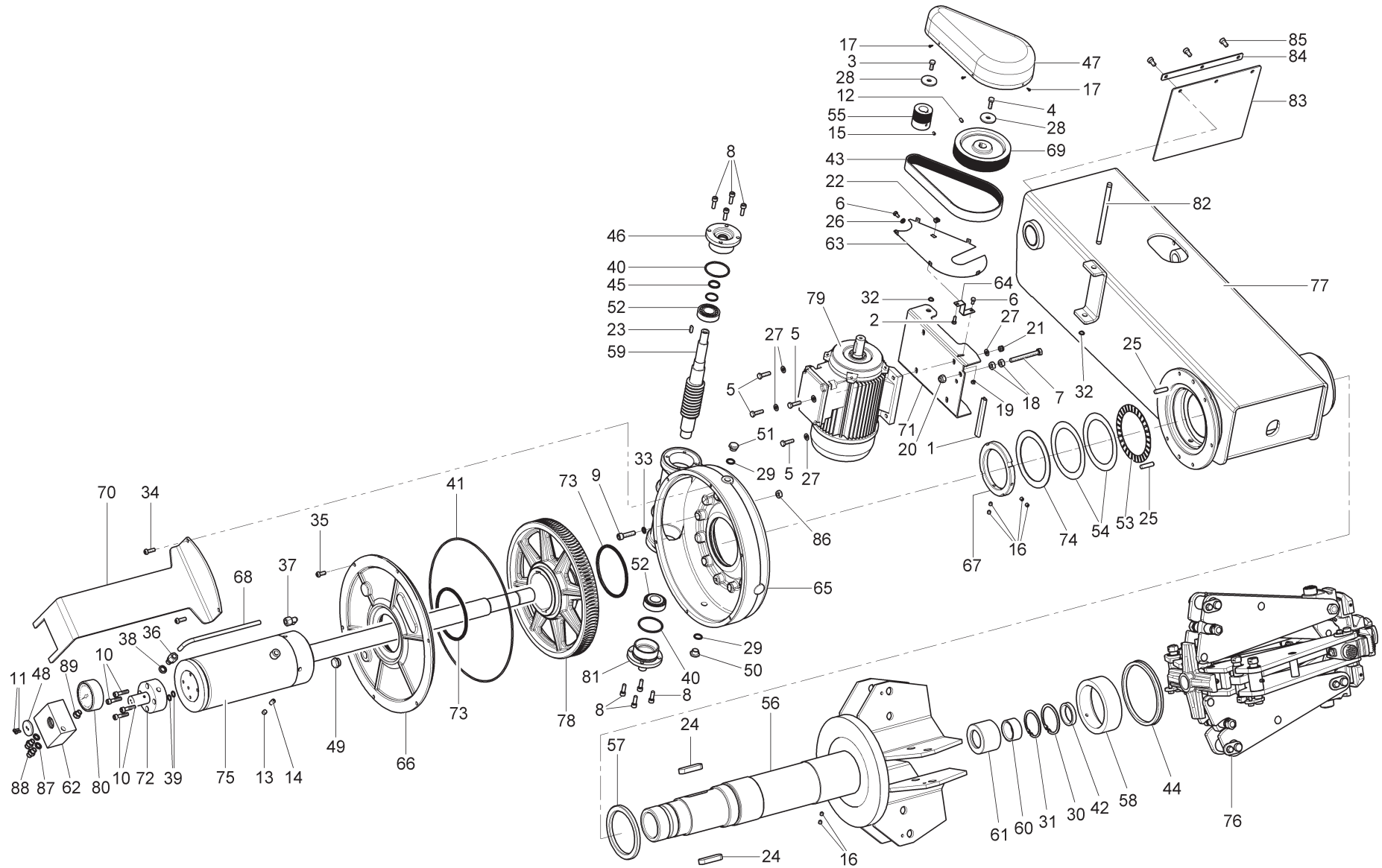
G9256.11SL	G9256.11ST	G9256.15	G9256T.15	G9256A.15	G9256D.15	G9256TD.15	G9256.15SL	G10360.15	G10360T.15	G10360A.15	G10360D.15	G10360TD.15					
•	•	•	•	•	•	•	•										
 RAVAGLIOLI S.p.A.		LISTA DEI COMPONENTI - LIST OF COMPONENTS - TEILELISTE LISTE DES PIÈCES DÉTACHÉES - LISTA DE PIEZAS						CILINDRO AUTOCENTRANTE SELF-CENTERING CYLINDER AUTOZENTRIERZYLINDER CYLINDRE AUTOCENTREUR CILINDRO AUTOCENTRANTE					Pag. 20 di 76				
		Tavola N°12 - Rev. 1			752290780												



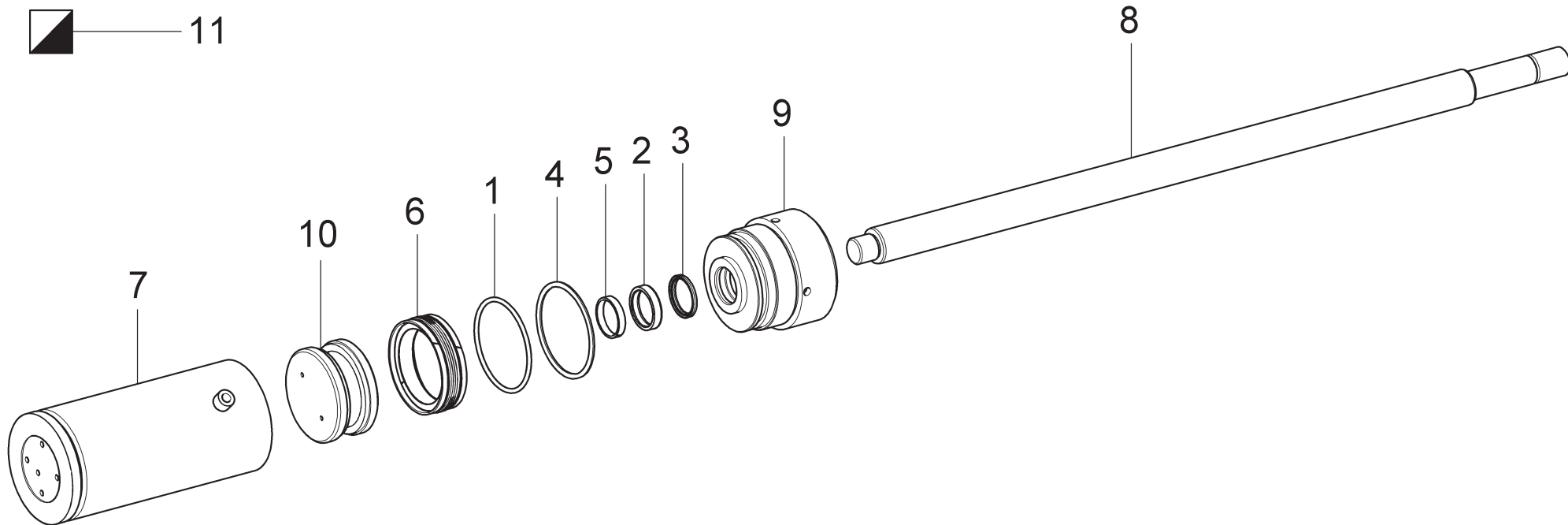
G9256.11SL	G9256.11ST	G9256.15	G9256T.15	G9256A.15	G9256D.15	G9256TD.15	G9256.15SL	G10360.15	G10360T.15	G10360A.15	G10360D.15	G10360TD.15																			
		•	•	•																											
 RAVAGLIOLI S.p.A.		LISTA DEI COMPONENTI - LIST OF COMPONENTS - TEILELISTE LISTE DES PIÈCES DÉTACHÉES - LISTA DE PIEZAS						Tavola N°13 - Rev. 5						752290770						ASSIEME BRACCIO MANDRINO MANDREL ARM ASSEMBLY SPINDELSARMENSEMBLE ASSEMBLAGE BRAS MANDRIN ENSEMBLADO BRAZO MANDRIL						Pag. 21 di 76					



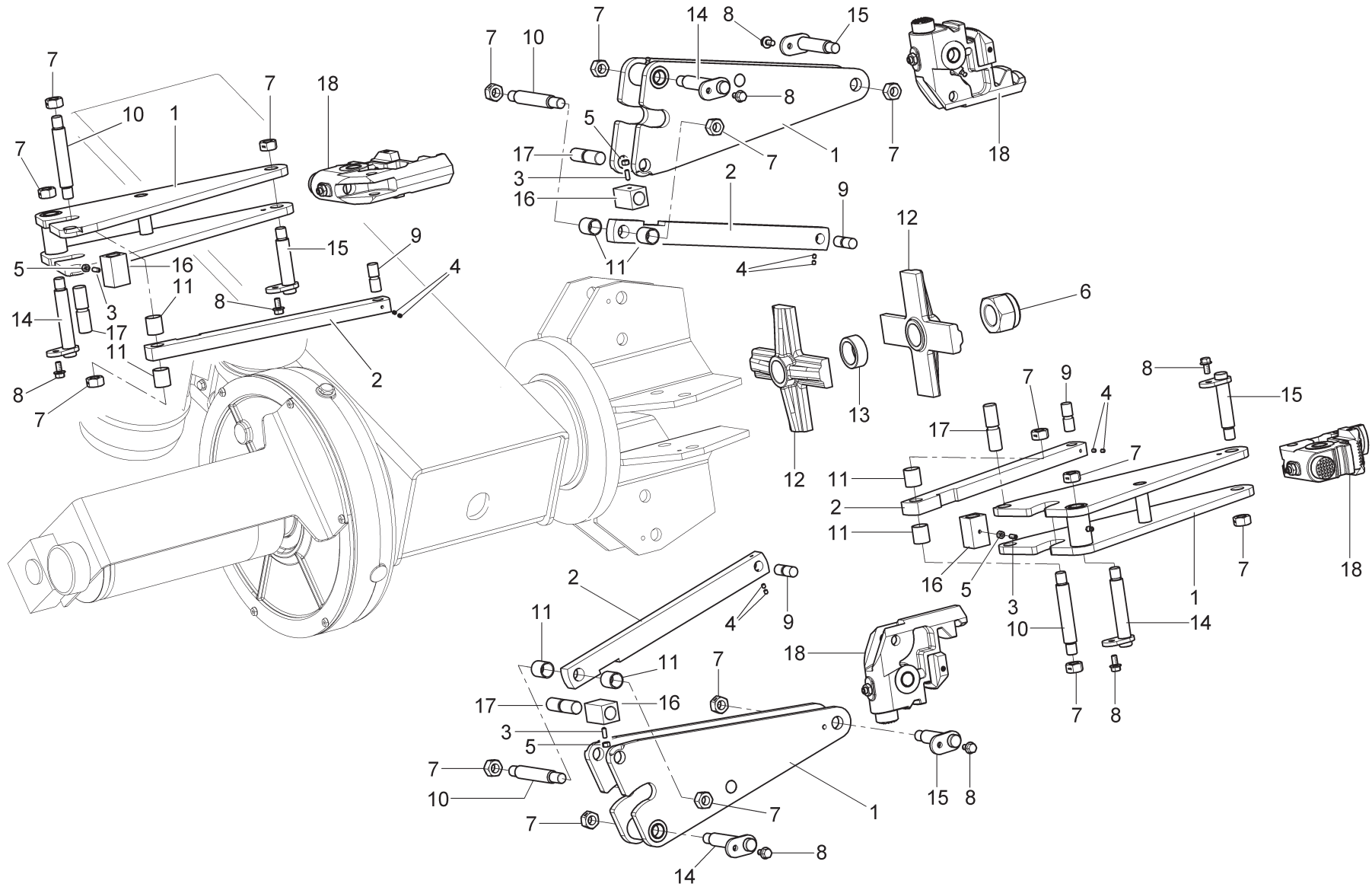
G9256.11SL	G9256.11ST	G9256.15	G9256T.15	G9256A.15	G9256D.15	G9256TD.15	G9256.15SL	G10360.15	G10360T.15	G10360A.15	G10360D.15	G10360TD.15				
		•	•	•												
 RAVAGLIOLI S.p.A.		LISTA DEI COMPONENTI - LIST OF COMPONENTS - TEILELISTE LISTE DES PIÈCES DÉTACHÉES - LISTA DE PIEZAS						GRUPPO MOTORE ELETTRICO ELECTRIC MOTOR UNIT ELEKTRISCHER MOTORSATZ GROUPE MOTEUR ÉLECTRIQUE GRUPO MOTOR ELÉCTRICO					Pag. 22 di 76			
Tavola N°14 - Rev. 0						752290790										



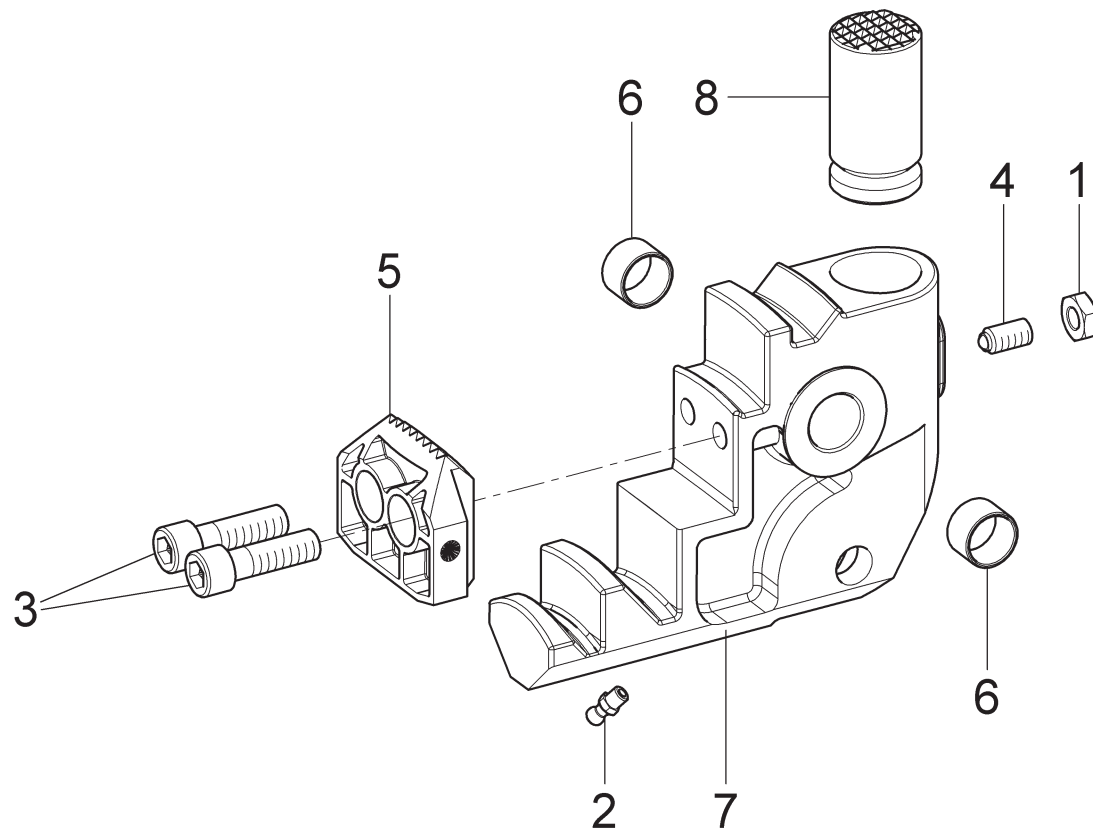
G9256.11SL	G9256.11ST	G9256.15	G9256T.15	G9256A.15	G9256D.15	G9256TD.15	G9256.15SL	G10360.15	G10360T.15	G10360A.15	G10360D.15	G10360TD.15									
								•	•	•											
 RAVAGLIOLI S.p.A.		LISTA DEI COMPONENTI - LIST OF COMPONENTS - TEILELISTE LISTE DES PIÈCES DÉTACHÉES - LISTA DE PIEZAS						Tavola N°15 - Rev. 5					752290170					GRUPPO BRACCIO MANDRINO MANDREL ARM UNIT SPINDELARMSATZ GROUPE BRAS MANDRIN GRUPO BRAZO MANDRIL		Pag. 23 di 76	




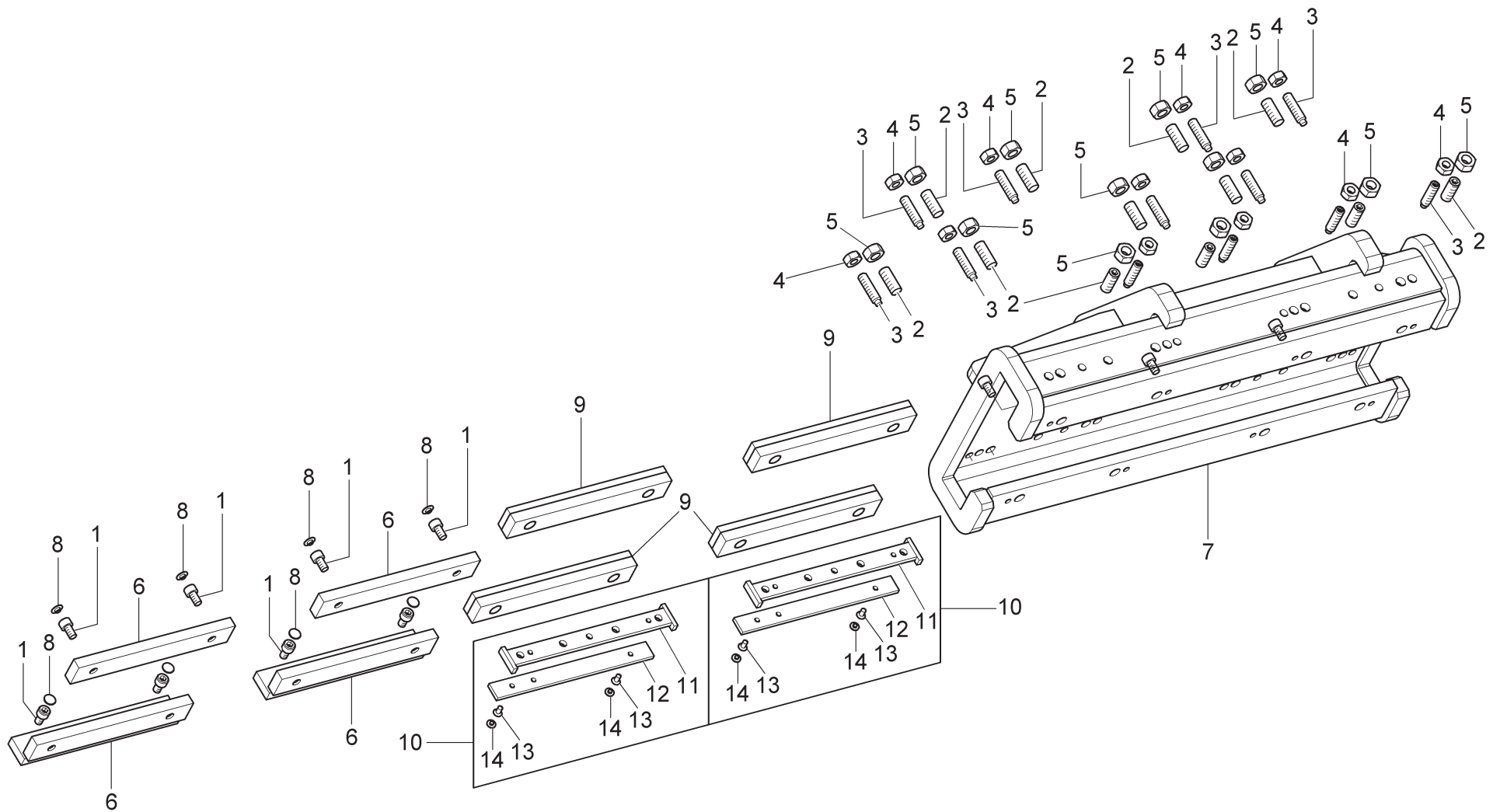
G9256.11SL	G9256.11ST	G9256.15	G9256T.15	G9256A.15	G9256D.15	G9256TD.15	G9256.15SL	G10360.15	G10360T.15	G10360A.15	G10360D.15	G10360TD.15				
								•	•	•	•	•				
 RAVAGLIOLI S.p.A.		LISTA DEI COMPONENTI - LIST OF COMPONENTS - TEILELISTE LISTE DES PIÈCES DÉTACHÉES - LISTA DE PIEZAS						CILINDRO CYLINDER ZYLINDER CYLINDRE CILINDRO					Pag. 24 di 76			
Tavola N°16 - Rev. 1						752290130										



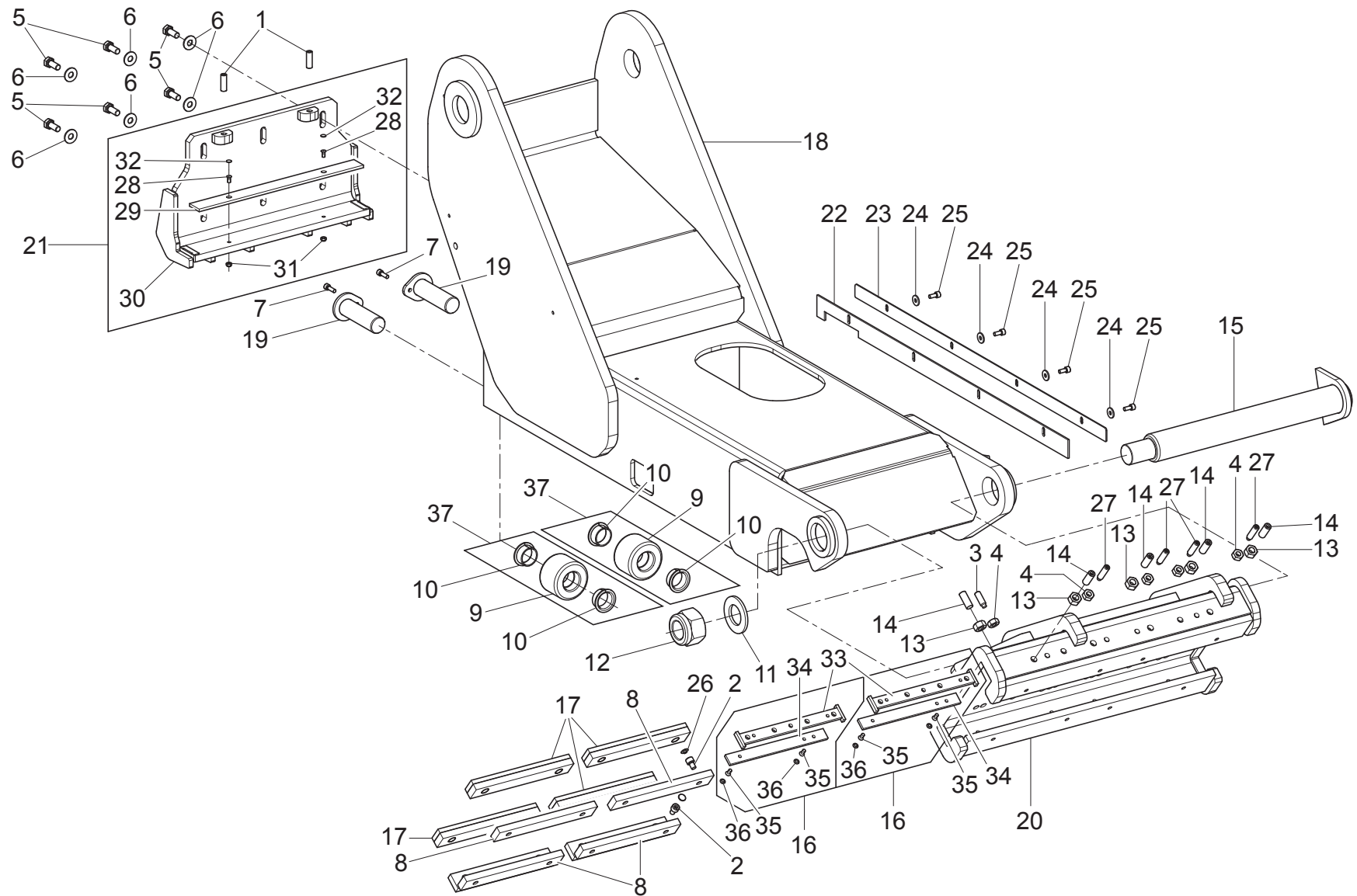
G9256.11SL	G9256.11ST	G9256.15	G9256T.15	G9256A.15	G9256D.15	G9256TD.15	G9256.15SL	G10360.15	G10360T.15	G10360A.15	G10360D.15	G10360TD.15					
								•	•	•	•	•					
 RAVAGLIOLI S.p.A.		LISTA DEI COMPONENTI - LIST OF COMPONENTS - TEILELISTE LISTE DES PIÈCES DÉTACHÉES - LISTA DE PIEZAS						GRUPPO BRACCI MANDRINO MANDREL ARMS UNIT SPINDELSARMSATZ GROUPE BRAS MANDRIN GRUPO BRAZOS MANDRIL						Pag. 25 di 76			
		Tavola N°17 - Rev. 1						752290250									



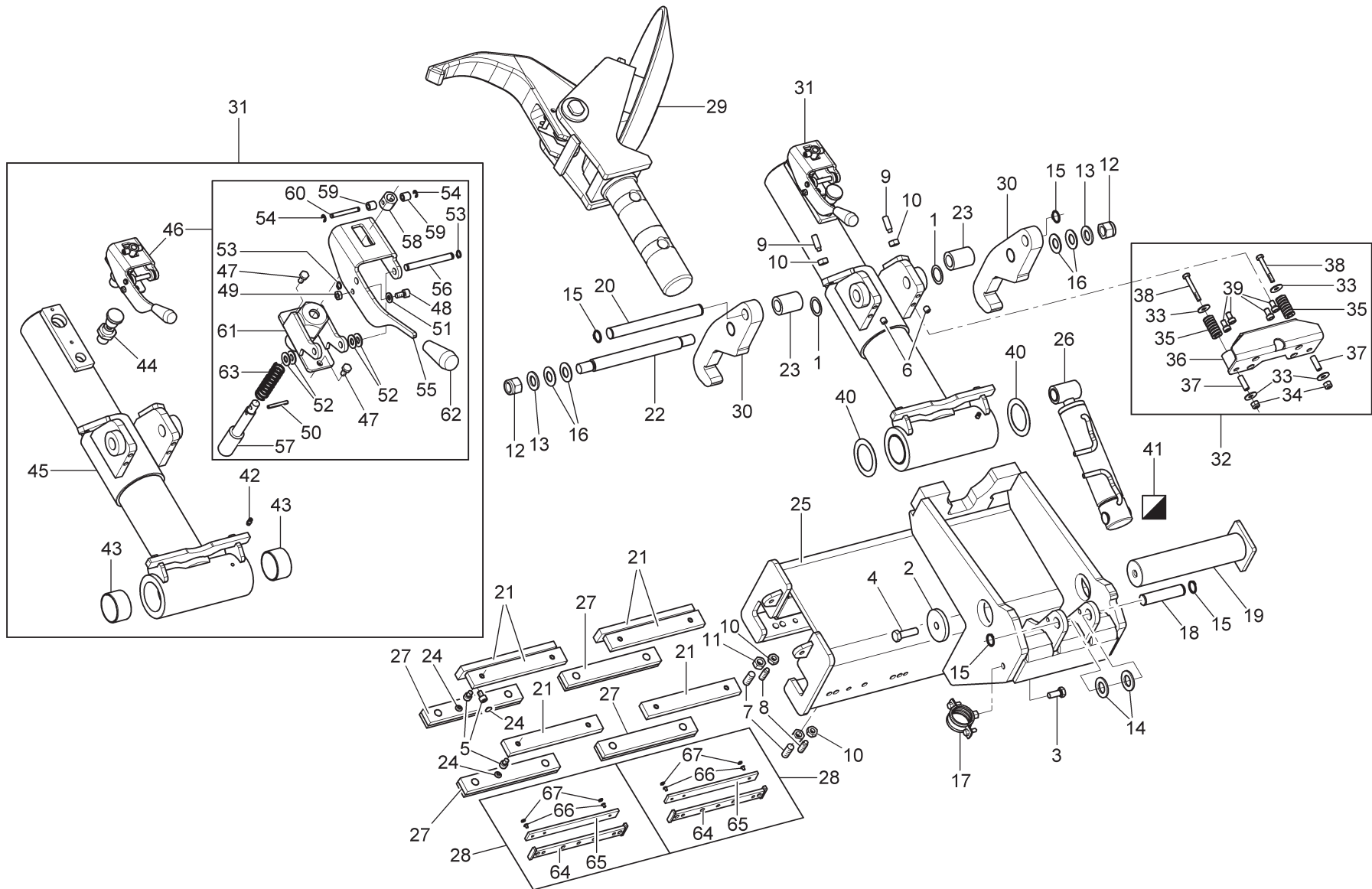
G9256.11SL	G9256.11ST	G9256.15	G9256T.15	G9256A.15	G9256D.15	G9256TD.15	G9256.15SL	G10360.15	G10360T.15	G10360A.15	G10360D.15	G10360TD.15				
•	•	•	•	•	•	•	•	•	•	•	•	•				
 RAVAGLIOLI S.p.A.		LISTA DEI COMPONENTI - LIST OF COMPONENTS - TEILELISTE LISTE DES PIÈCES DÉTACHÉES - LISTA DE PIEZAS						GRIFFA COMPLETA COMPLETE JAW KOMPLLETTE KLAUE GRIFFE COMPLETE GANCHO COMPLETO					Pag. 26 di 76			
		Tavola N°18 - Rev. 1			B9641000											



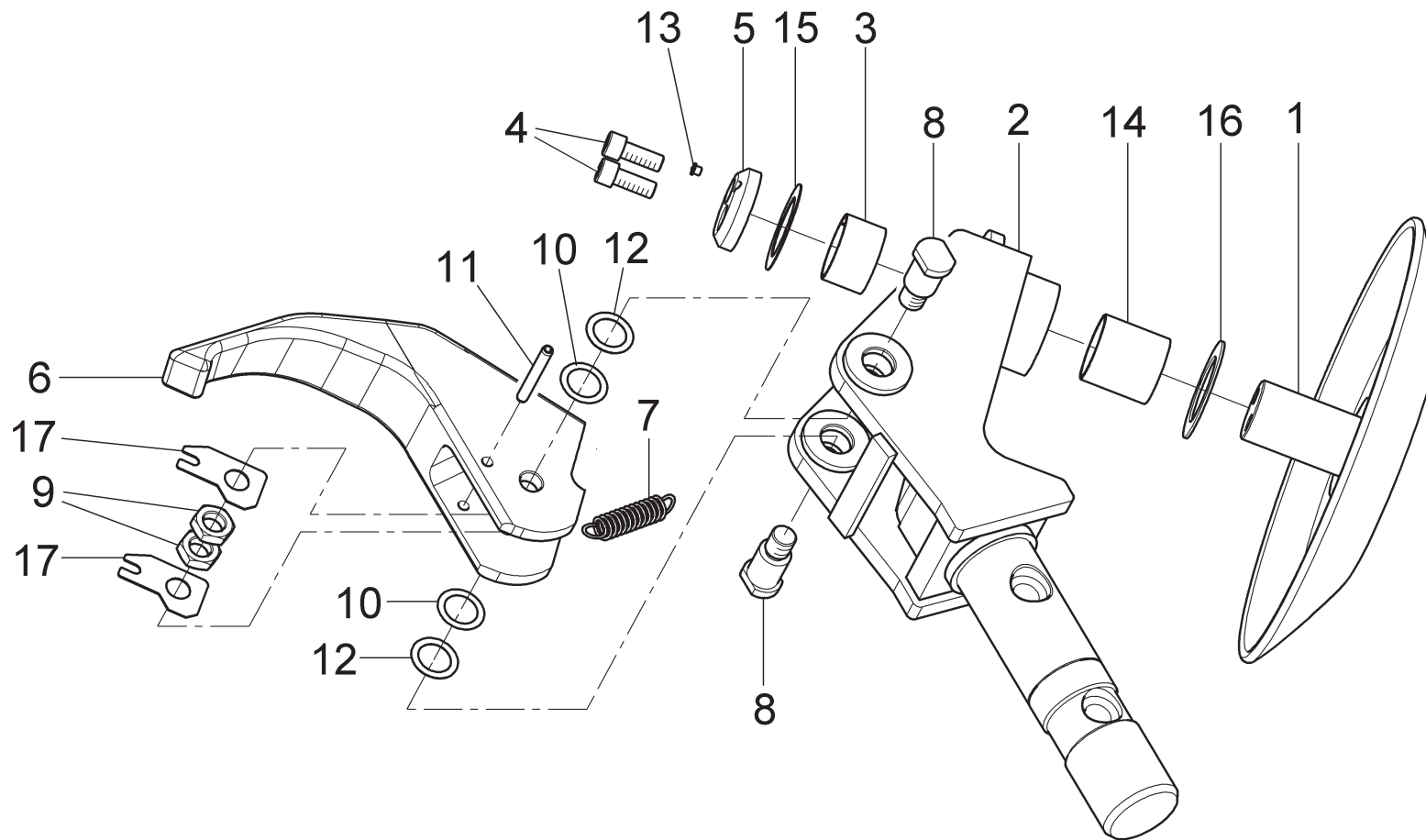
G9256.11SL	G9256.11ST	G9256.15	G9256T.15	G9256A.15	G9256D.15	G9256TD.15	G9256.15SL	G10360.15	G10360T.15	G10360A.15	G10360D.15	G10360TD.15					
•	•	•	•	•	•	•	•										
 RAVAGLIOLI S.p.A.		LISTA DEI COMPONENTI - LIST OF COMPONENTS - TEILELISTE LISTE DES PIÈCES DÉTACHÉES - LISTA DE PIEZAS						SUPPORTO CON PATTINI SUPPORT WITH SLIDING BLOCKS TRÄGER MIT SCHLITTENEN SUPPORT AVEC PATINES SOPORTE CON PATINES					Pag. 27 di 76				
Tavola N°19 - Rev. 1							752291080										



G9256.11SL	G9256.11ST	G9256.15	G9256T.15	G9256A.15	G9256D.15	G9256TD.15	G9256.15SL	G10360.15	G10360T.15	G10360A.15	G10360D.15	G10360TD.15				
								•	•	•	•	•				
 RAVAGLIOLI S.p.A.		LISTA DEI COMPONENTI - LIST OF COMPONENTS - TEILELISTE LISTE DES PIÈCES DÉTACHÉES - LISTA DE PIEZAS						GRUPPO BRACCIO ORIZZONTALE HORIZONTAL ARM UNIT HORIZONTALARMSATZ GROUPE BRAS HORIZONTAL GRUPO BRAZO HORIZONTAL					Pag. 28 di 76			
		Tavola N°20 - Rev. 2			752290270											



G9256.11SL	G9256.11ST	G9256.15	G9256T.15	G9256A.15	G9256D.15	G9256TD.15	G9256.15SL	G10360.15	G10360T.15	G10360A.15	G10360D.15	G10360TD.15				
•							•									
 RAVAGLIOLI S.p.A.		LISTA DEI COMPONENTI - LIST OF COMPONENTS - TEILELISTE LISTE DES PIÈCES DÉTACHÉES - LISTA DE PIEZAS							GRUPPO CARRO UTENSILI TOOLS CARRIAGE UNIT WERKZEUGSWAGENSATZ GROUPE CHARIOT OUTILS GRUPO CARRO UTENSILIOS				Pag. 29 di 76			
		Tavola N°21 - Rev. 2							752291980							



G9256.11SL	G9256.11ST	G9256.15	G9256T.15	G9256A.15	G9256D.15	G9256TD.15	G9256.15SL	G10360.15	G10360T.15	G10360A.15	G10360D.15	G10360TD.15					
•	•						•										



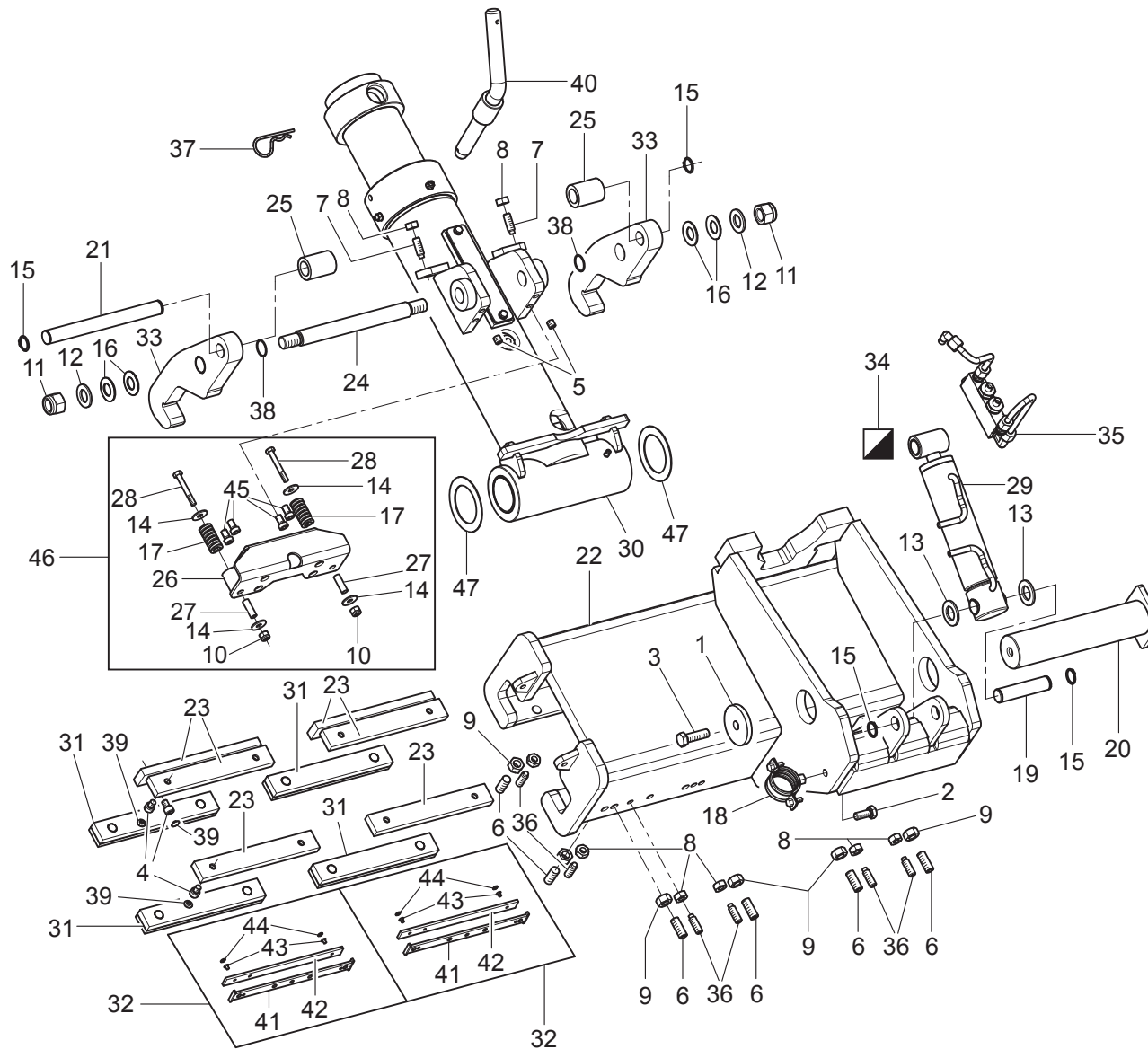
**LISTA DEI COMPONENTI - LIST OF COMPONENTS - TEILELISTE
LISTE DES PIÈCES DÉTACHÉES - LISTA DE PIEZAS**

Tavola N°22 - Rev. 2

146590063

GRUPPO UTENSILE DOPPIO
DOUBLE TOOL UNIT
DOPPELWERKZEUGSATZ
GROUPE OUTIL DOUBLE
GRUPO UTENSILIO DOBLE

Pag. 30 di 76



G9256.11SL	G9256.11ST	G9256.15	G9256T.15	G9256A.15	G9256D.15	G9256TD.15	G9256.15SL	G10360.15	G10360T.15	G10360A.15	G10360D.15	G10360TD.15				
		•	•	•	•	•										


 RAVAGLIOLI S.p.A.

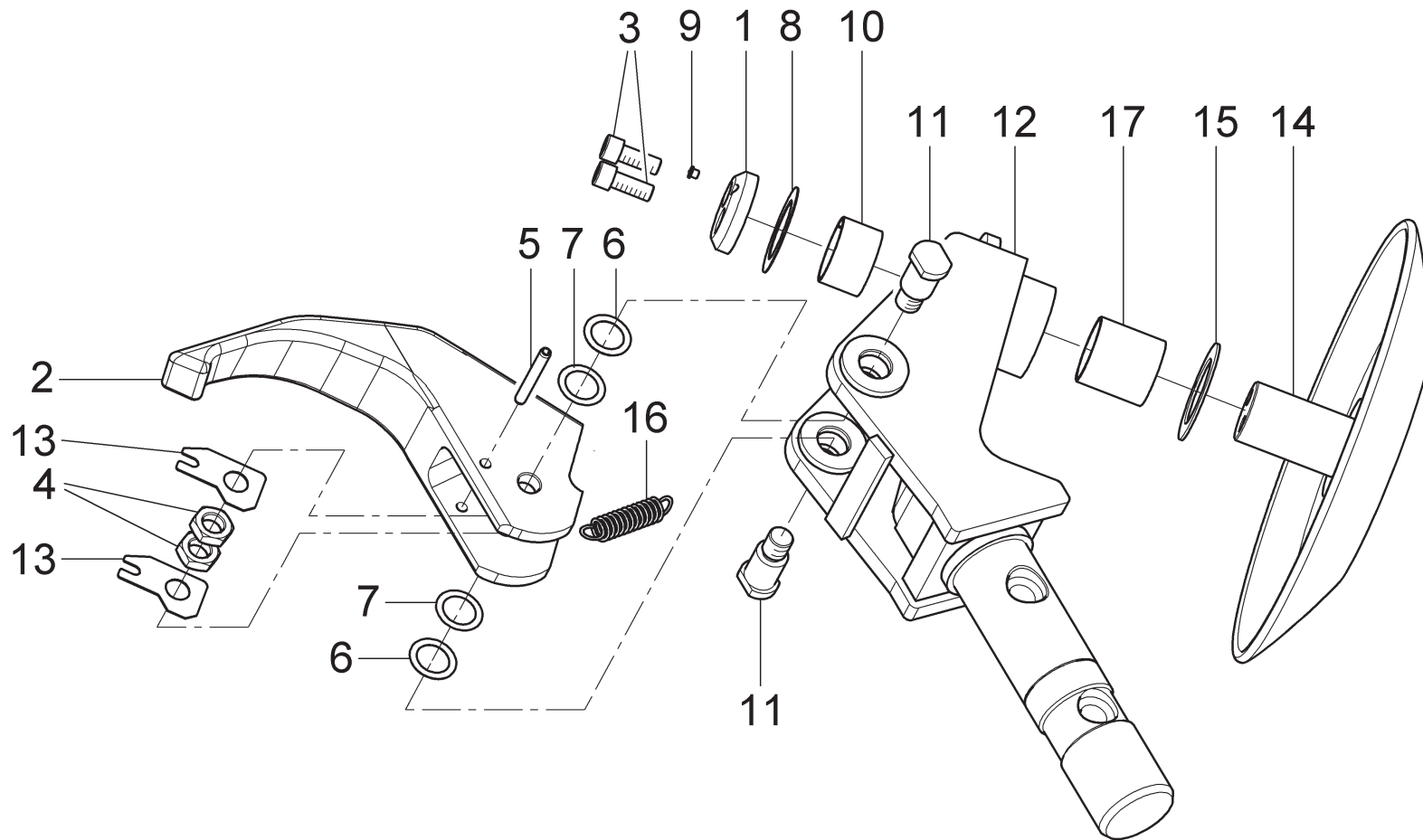
LISTA DEI COMPONENTI - LIST OF COMPONENTS - TEILELISTE
LISTE DES PIÈCES DÉTACHÉES - LISTA DE PIEZAS

Tavola N°23 - Rev. 8

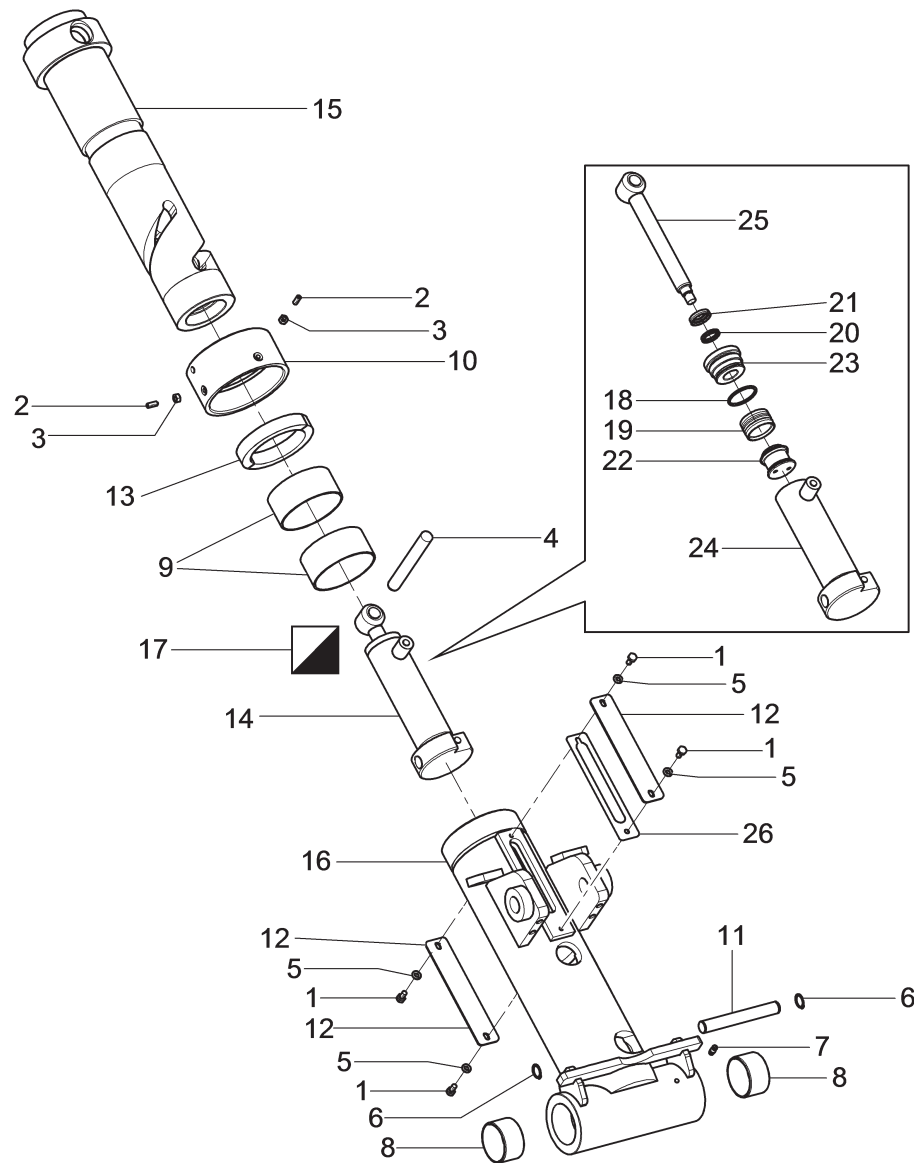
752291800

GRUPPO CARRO UTENSILI
 TOOLS CARRIAGE UNIT
 WERKZEUGSWAGENSATZ
 GROUPE CHARIOT OUTILS
 GRUPO CARRO UTENSILIOS

Pag. 31 di 76



G9256.11SL	G9256.11ST	G9256.15	G9256T.15	G9256A.15	G9256D.15	G9256TD.15	G9256.15SL	G10360.15	G10360T.15	G10360A.15	G10360D.15	G10360TD.15				
		•		•	•											
 RAVAGLIOLI S.p.A.		LISTA DEI COMPONENTI - LIST OF COMPONENTS - TEILELISTE LISTE DES PIÈCES DÉTACHÉES - LISTA DE PIEZAS						GRUPPO UTENSILI TOOLS UNIT WERKZEUGSATZ GROUPE OUTILES GRUPO UTENSILIOS					Pag. 32 di 76			
Tavola N°24 - Rev. 2						752290890										



G9256.11SL	G9256.11ST	G9256.15	G9256T.15	G9256A.15	G9256D.15	G9256TD.15	G9256.15SL	G10360.15	G10360T.15	G10360A.15	G10360D.15	G10360TD.15				
		•	•	•	•	•										


 RAVAGLIOLI S.p.A.

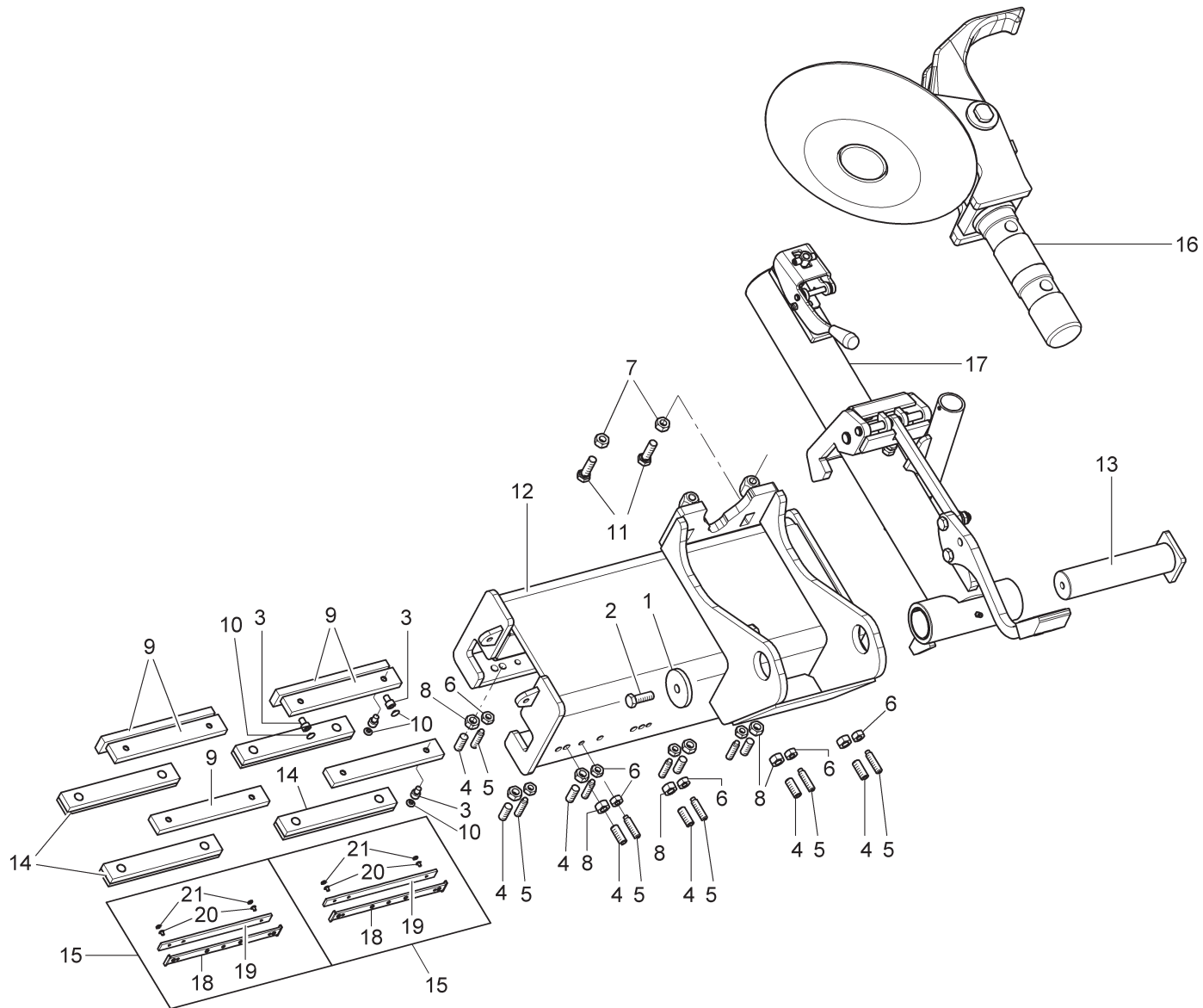
LISTA DEI COMPONENTI - LIST OF COMPONENTS - TEILELISTE
LISTE DES PIÈCES DÉTACHÉES - LISTA DE PIEZAS

Tavola N°25 - Rev. 6

752291811

GRUPPO ASTUCCIO CON BOCCOLE
 CASE UNIT WITH BUSHING
 KASTENSATZ MIT BUCHSE
 GROUPE ÉTUI AVEC DOUILLE
 GRUPO ESTUCHE CON CASQUILLO

Pag. 33 di 76



G9256.11SL	G9256.11ST	G9256.15	G9256T.15	G9256A.15	G9256D.15	G9256TD.15	G9256.15SL	G10360.15	G10360T.15	G10360A.15	G10360D.15	G10360TD.15					
	•																

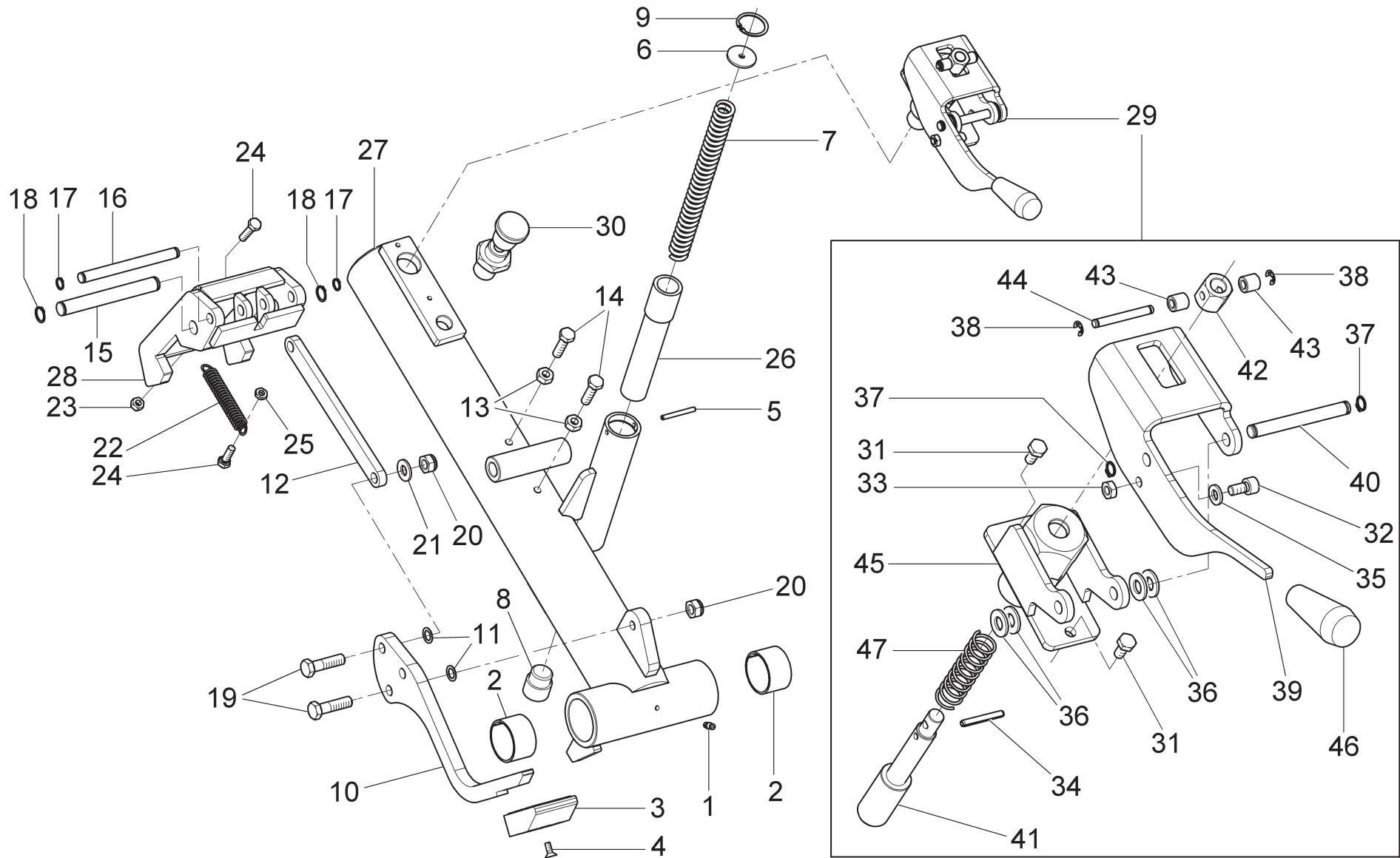


**LISTA DEI COMPONENTI - LIST OF COMPONENTS - TEILELISTE
LISTE DES PIÈCES DÉTACHÉES - LISTA DE PIEZAS**

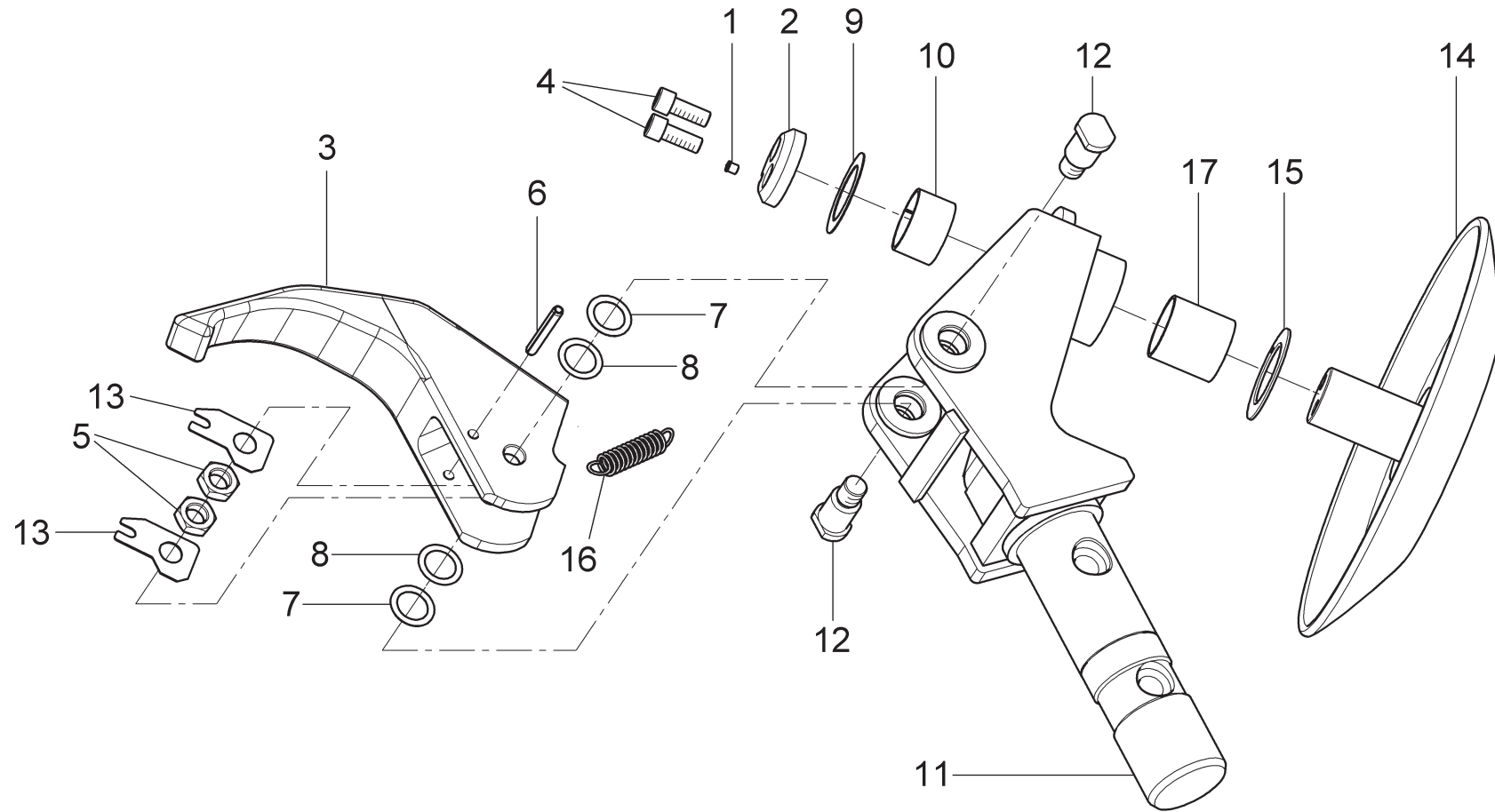
Tavola N°26 - Rev. 2

752291300

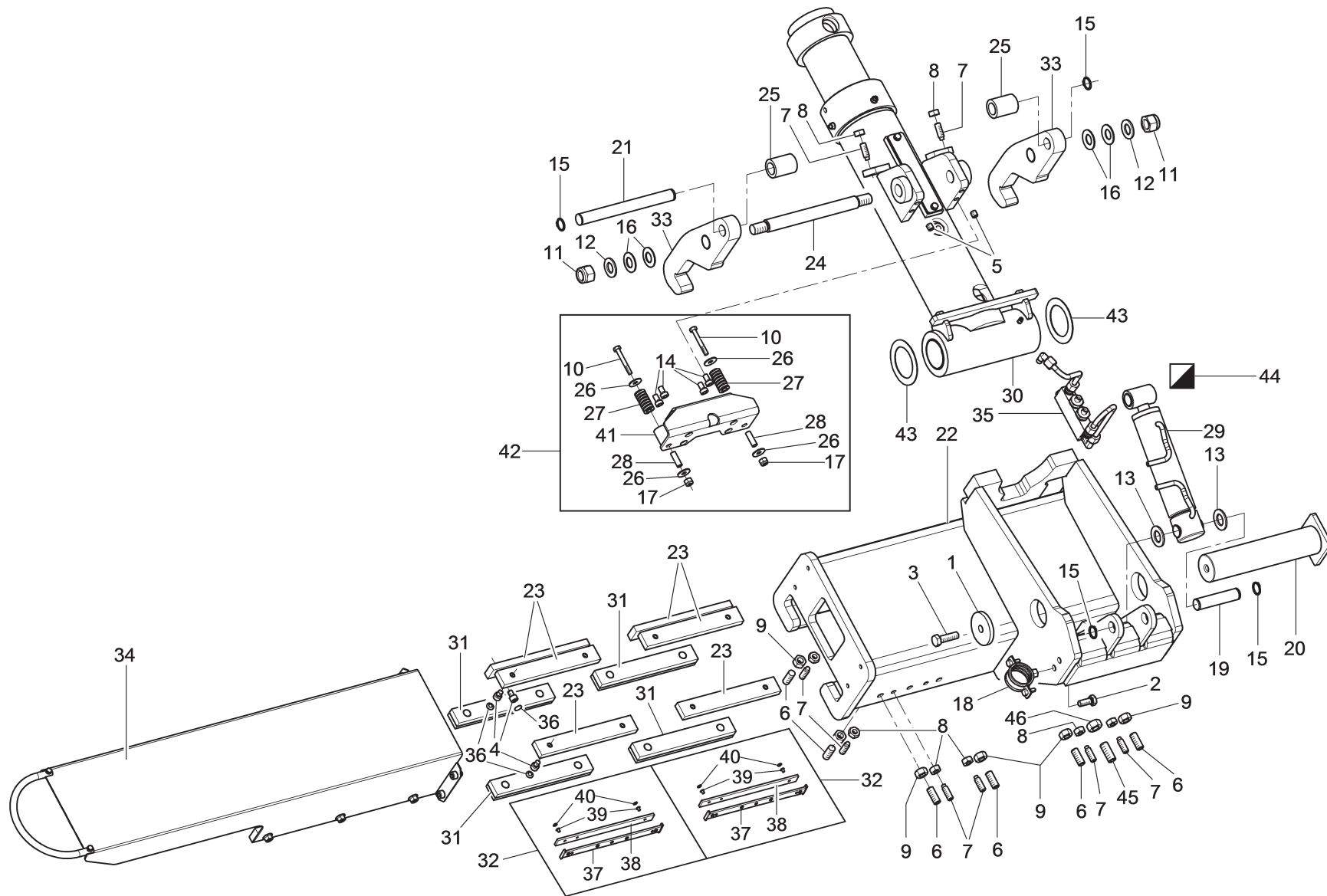
GRUPPO CARRO ASTUCCIO MANUALE
MANUAL CASE CARRIAGE UNIT
HANDSATZ DES WAGENKASTENS
GROUPE CHARIOT ÉTUI MANUEL
GRUPO CARRO ESTUCHE MANUAL



G9256.11SL	G9256.11ST	G9256.15	G9256T.15	G9256A.15	G9256D.15	G9256TD.15	G9256.15SL	G10360.15	G10360T.15	G10360A.15	G10360D.15	G10360TD.15					
	•																
 RAVAGLIOLI S.p.A.		LISTA DEI COMPONENTI - LIST OF COMPONENTS - TEILELISTE LISTE DES PIÈCES DÉTACHÉES - LISTA DE PIEZAS						GRUPPO ASTUCCIO MANUALE MANUAL CASE UNIT HANDKASTENSATZ GROUPE ÉTUI MANUEL GRUPO ESTUCHE MANUAL					Pag. 35 di 76				
Tavola N°27 - Rev. 0		752291311															



G9256.11SL	G9256.11ST	G9256.15	G9256T.15	G9256A.15	G9256D.15	G9256TD.15	G9256.15SL	G10360.15	G10360T.15	G10360A.15	G10360D.15	G10360TD.15					
								•		•	•						
 RAVAGLIOLI S.p.A.		LISTA DEI COMPONENTI - LIST OF COMPONENTS - TEILELISTE LISTE DES PIÈCES DÉTACHÉES - LISTA DE PIEZAS						GRUPPO UTENSILI TOOLS UNIT WERKZEUGSATZ GROUPE OUTILS GRUPO UTENSILIOS					Pag. 36 di 76				
		Tavola N°28 - Rev. 2			752290221												



G9256.11SL	G9256.11ST	G9256.15	G9256T.15	G9256A.15	G9256D.15	G9256TD.15	G9256.15SL	G10360.15	G10360T.15	G10360A.15	G10360D.15	G10360TD.15						
								•		•	•							



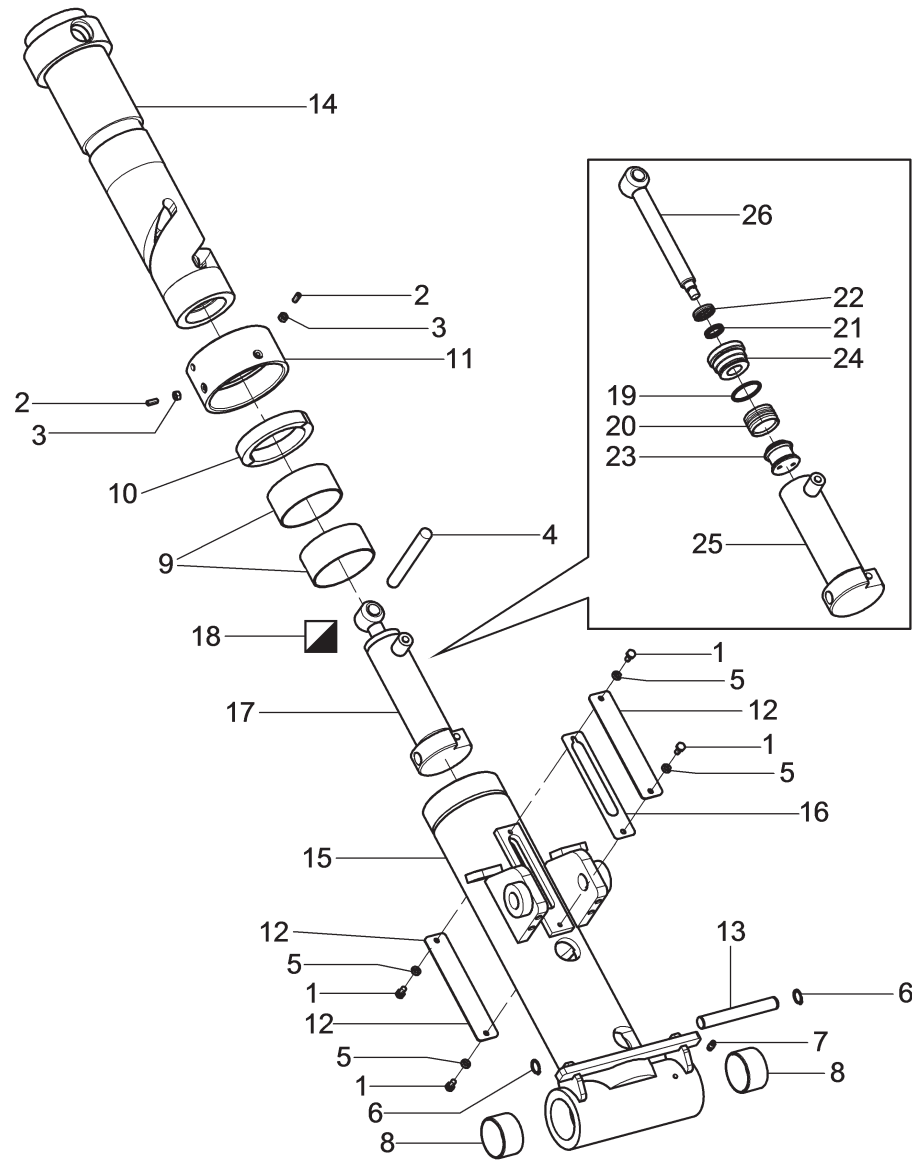
**LISTA DEI COMPONENTI - LIST OF COMPONENTS - TEILELISTE
LISTE DES PIÈCES DÉTACHÉES - LISTA DE PIEZAS**

Tavola N°29 - Rev. 6

752290090

CARRO
CARRIAGE
WAGEN
CHARIOT
CARRO

Pag. 37 di 76



G9256.11SL	G9256.11ST	G9256.15	G9256T.15	G9256A.15	G9256D.15	G9256TD.15	G9256.15SL	G10360.15	G10360T.15	G10360A.15	G10360D.15	G10360TD.15					
								•	•	•	•	•					



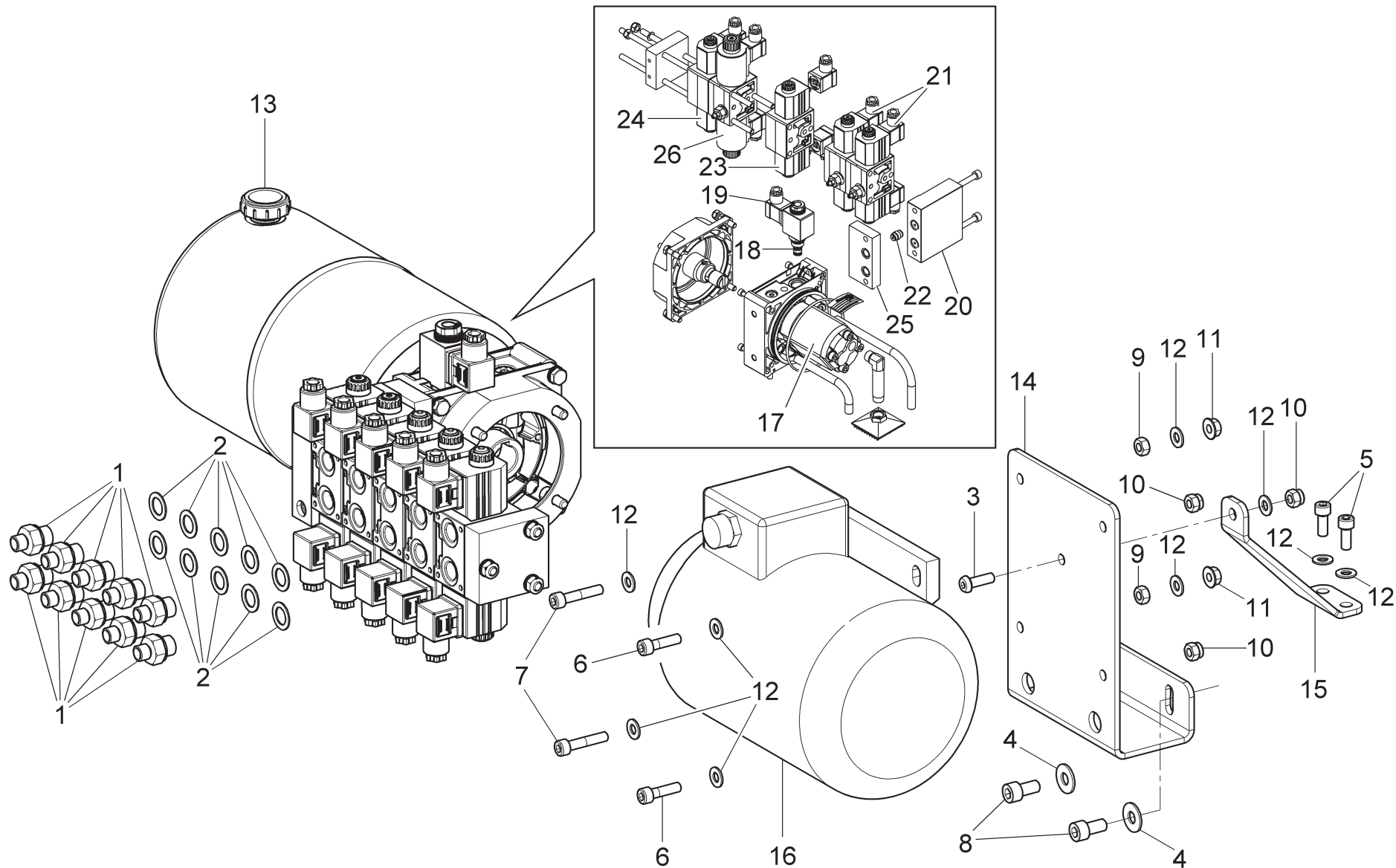
**LISTA DEI COMPONENTI - LIST OF COMPONENTS - TEILELISTE
LISTE DES PIÈCES DÉTACHÉES - LISTA DE PIEZAS**

Tavola N°30 - Rev. 4

752290552

STALLONATORE
BEAD BREAKER
ABDRÜCKER
DÉCOLLE-TALON
DESTALONADOR

Pag. 38 di 76



G9256.11SL	G9256.11ST	G9256.15	G9256T.15	G9256A.15	G9256D.15	G9256TD.15	G9256.15SL	G10360.15	G10360T.15	G10360A.15	G10360D.15	G10360TD.15						
•							•											



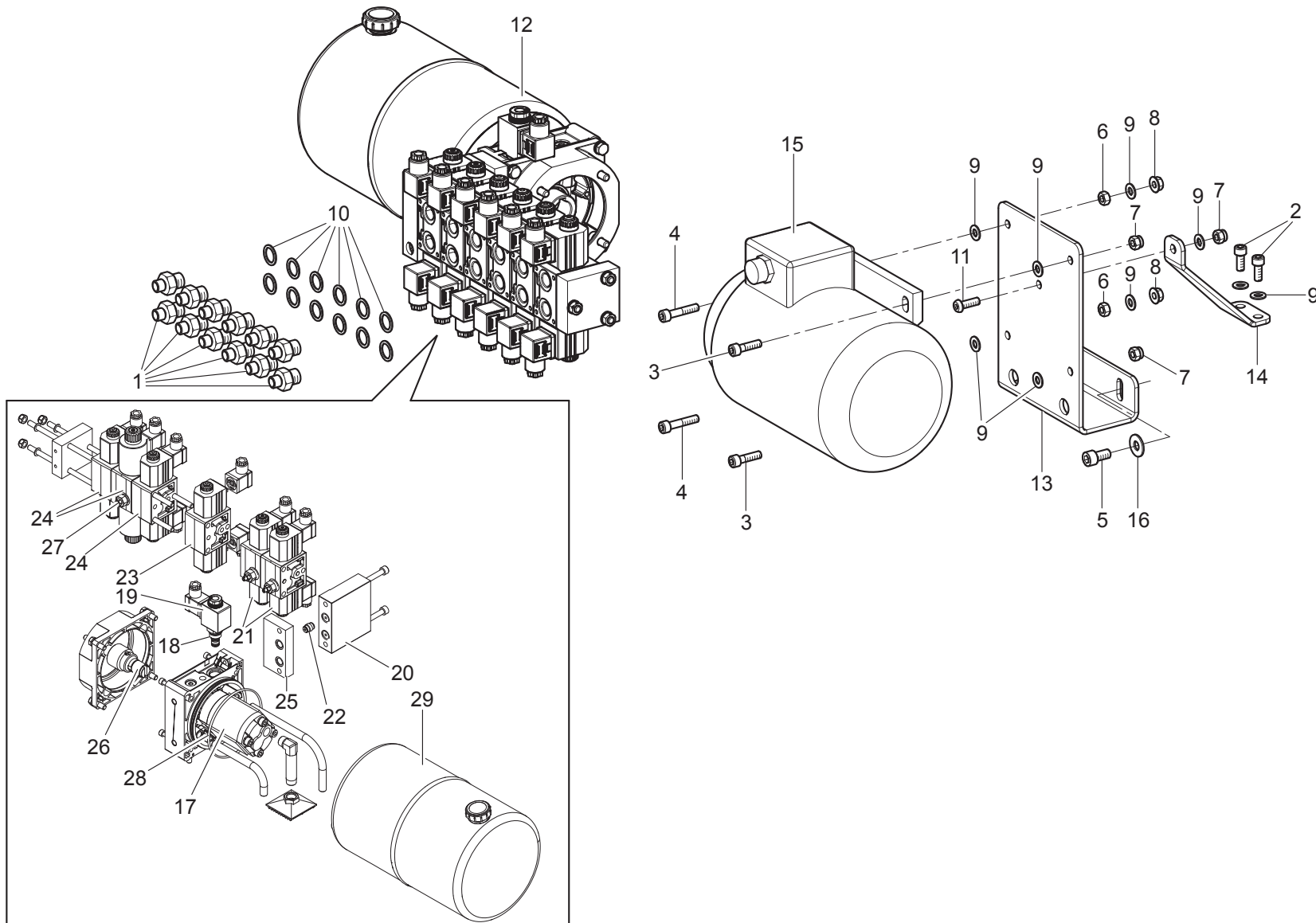
**LISTA DEI COMPONENTI - LIST OF COMPONENTS - TEILELISTE
LISTE DES PIÈCES DÉTACHÉES - LISTA DE PIEZAS**

Tavola N°31 - Rev. 2

752292010

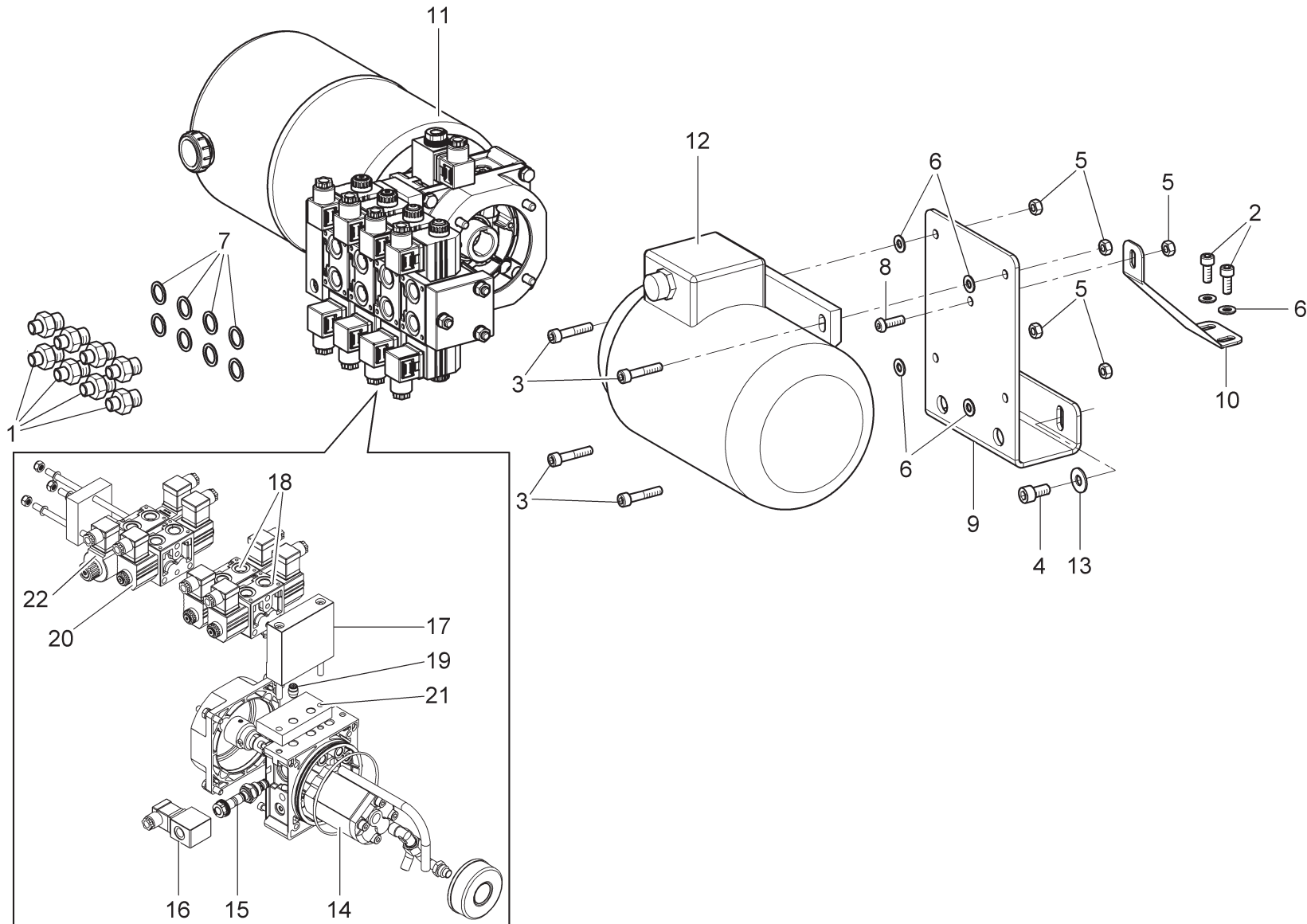
CENTRALINA COMPLETA
COMPLETE HYDRAULIC POWER UNIT
KOMPLETTER STEUERUNG
DISTRIBUTEUR COMPLÈTE
CENTRALITA COMPLETA

Pag. 39 di 76

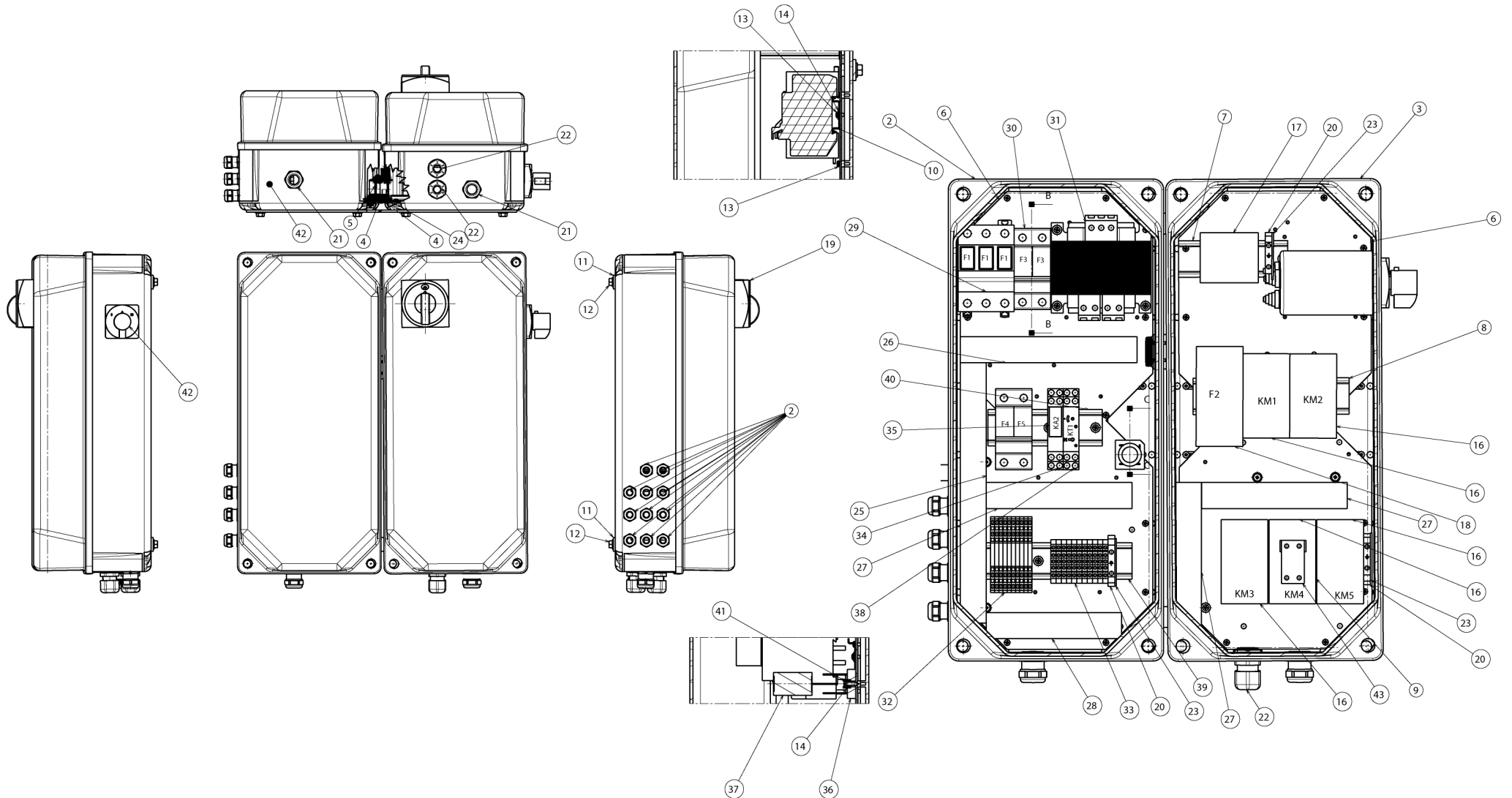


G9256.11SL	G9256.11ST	G9256.15	G9256T.15	G9256A.15	G9256D.15	G9256TD.15	G9256.15SL	G10360.15	G10360T.15	G10360A.15	G10360D.15	G10360TD.15					
		•	•	•	•	•											

 RAVAGLIOLI S.p.A.	LISTA DEI COMPONENTI - LIST OF COMPONENTS - TEILELISTE LISTE DES PIÈCES DÉTACHÉES - LISTA DE PIEZAS							CENTRALINA COMPLETA COMPLETE HYDRAULIC POWER UNIT KOMPLETTER STEUERUNG DISTRIBUTEUR COMPLÈTE CENTRALITA COMPLETA				Pag. 40 di 76			
	Tavola N°32 - Rev. 5			752290510											



G9256.11SL	G9256.11ST	G9256.15	G9256T.15	G9256A.15	G9256D.15	G9256TD.15	G9256.15SL	G10360.15	G10360T.15	G10360A.15	G10360D.15	G10360TD.15				
	•															
 RAVAGLIOLI S.p.A.		LISTA DEI COMPONENTI - LIST OF COMPONENTS - TEILELISTE LISTE DES PIÈCES DÉTACHÉES - LISTA DE PIEZAS						CENTRALINA COMPLETA COMPLETE HYDRAULIC POWER UNIT KOMPLETTER STEUERUNG DISTRIBUTEUR COMPLÈTE CENTRALITA COMPLETA					Pag. 41 di 76			
		Tavola N°33 - Rev. 2					752291320									



G9256.11SL	G9256.11ST	G9256.15	G9256T.15	G9256A.15	G9256D.15	G9256TD.15	G9256.15SL	G10360.15	G10360T.15	G10360A.15	G10360D.15	G10360TD.15						
•							•											


 RAVAGLIOLI S.p.A.

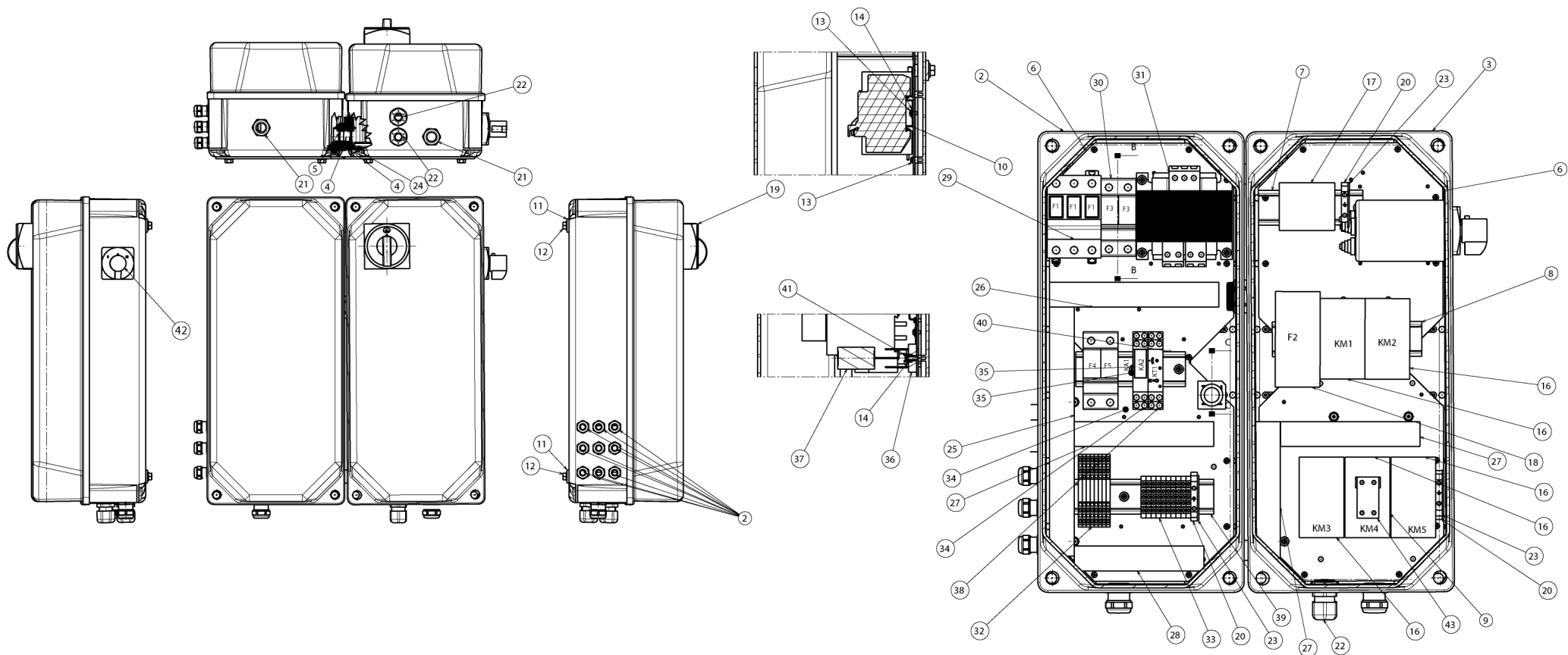
LISTA DEI COMPONENTI - LIST OF COMPONENTS - TEILELISTE
LISTE DES PIÈCES DÉTACHÉES - LISTA DE PIEZAS

Tavola N°34 - Rev. 2

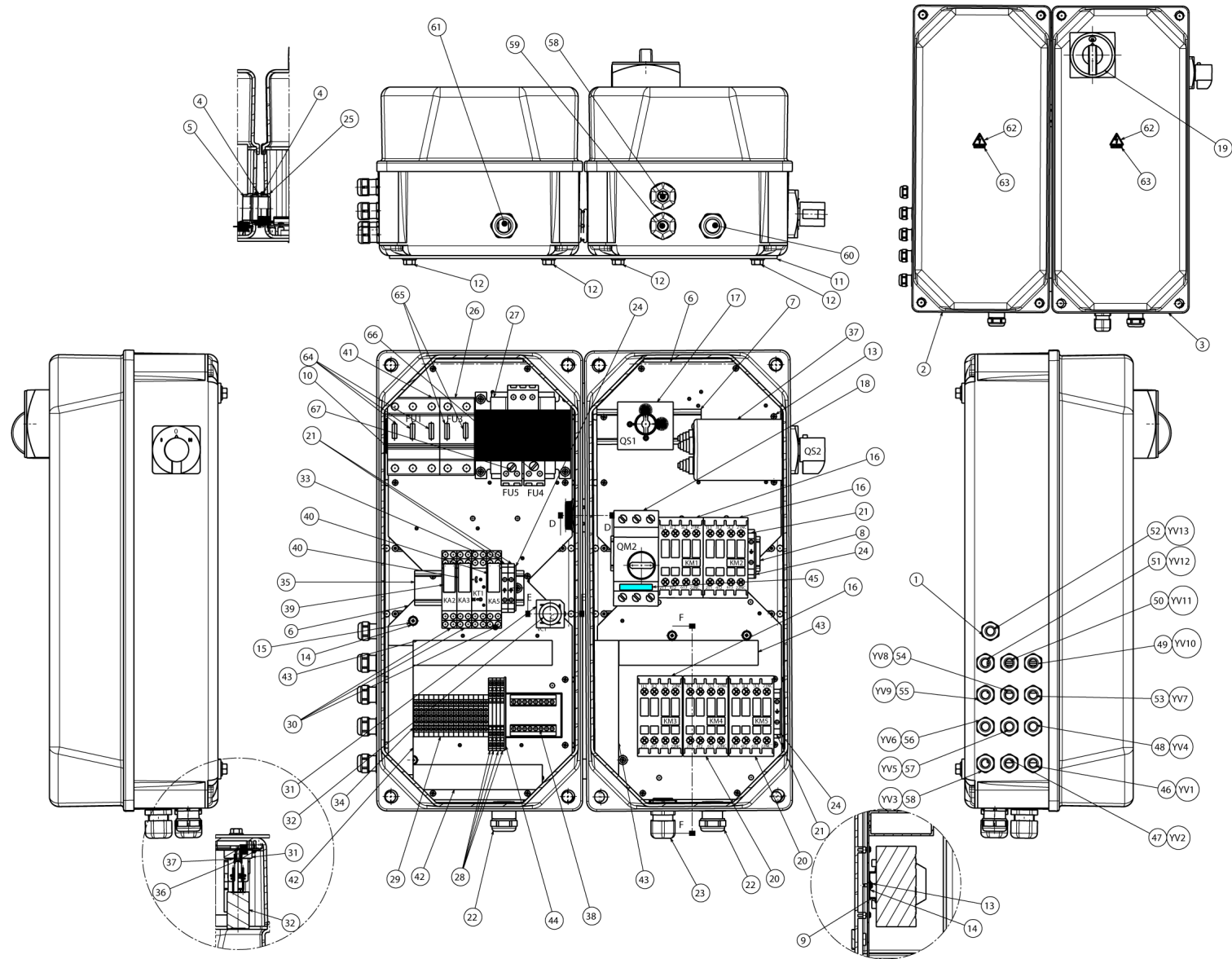
752203210

MTG CASSETTA ELETTRICA
 ELECTRIC BOX MTG
 MTG ELEKTRISCHEKISTE
 MTG BOÏTER ELECTRIQUE
 MTG CAJITA ELECTRICA

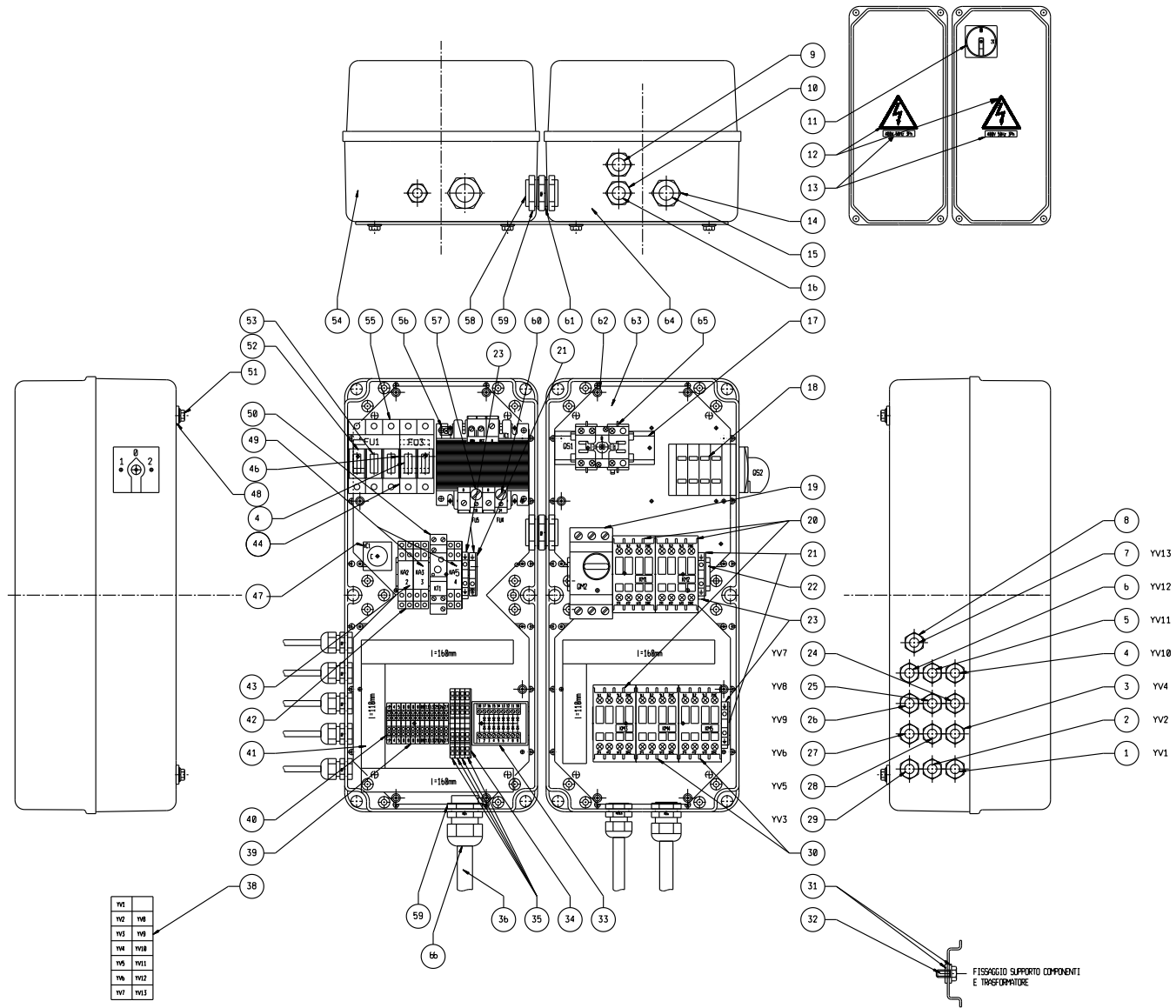
Pag. 42 di 76



G9256.11SL	G9256.11ST	G9256.15	G9256T.15	G9256A.15	G9256D.15	G9256TD.15	G9256.15SL	G10360.15	G10360T.15	G10360A.15	G10360D.15	G10360TD.15						
	•																	
 RAVAGLIOLI S.p.A.		LISTA DEI COMPONENTI - LIST OF COMPONENTS - TEILELISTE LISTE DES PIÈCES DÉTACHÉES - LISTA DE PIEZAS							MTG CASSETTA ELETTRICA ELECTRIC BOX MTG MTG ELEKTRISCHKISTE MTG BOÏTER ELECTRIQUE MTG CAJITA ELECTRICA					Pag. 43 di 76				
		Tavola N°35 - Rev. 2			752203220													

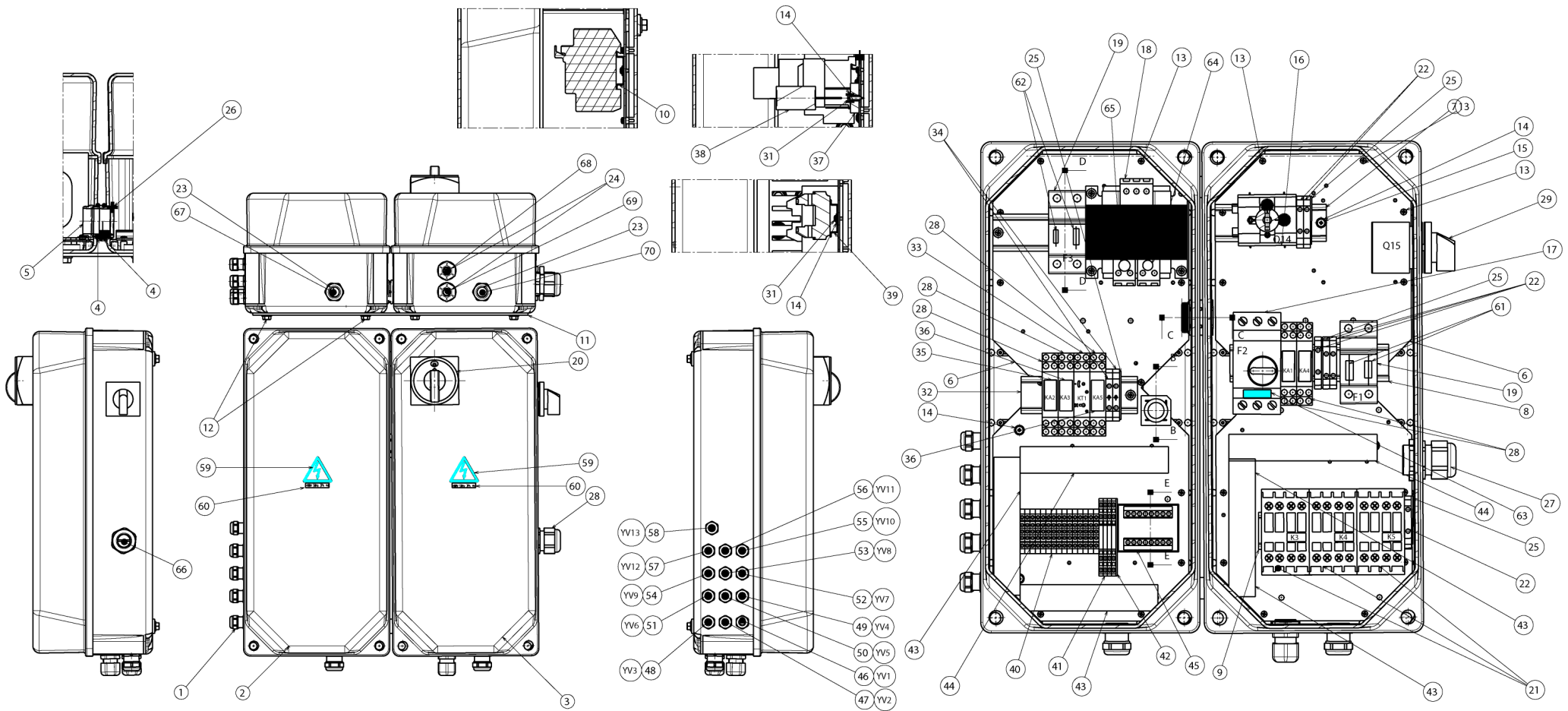



G9256.11SL	G9256.11ST	G9256.15	G9256T.15	G9256A.15	G9256D.15	G9256TD.15	G9256.15SL	G10360.15	G10360T.15	G10360A.15	G10360D.15	G10360TD.15						
		•	•					•	•									
 RAVAGLIOLI S.p.A.		LISTA DEI COMPONENTI - LIST OF COMPONENTS - TEILELISTE LISTE DES PIÈCES DÉTACHÉES - LISTA DE PIEZAS							MTG CASSETTA ELETTRICA ELECTRIC BOX MTG MTG ELEKTRISCHEKISTE MTG BOITER ELECTRIQUE MTG CAJITA ELECTRICA					Pag. 44 di 76				
		Tavola N°36 - Rev. 3							752203230									

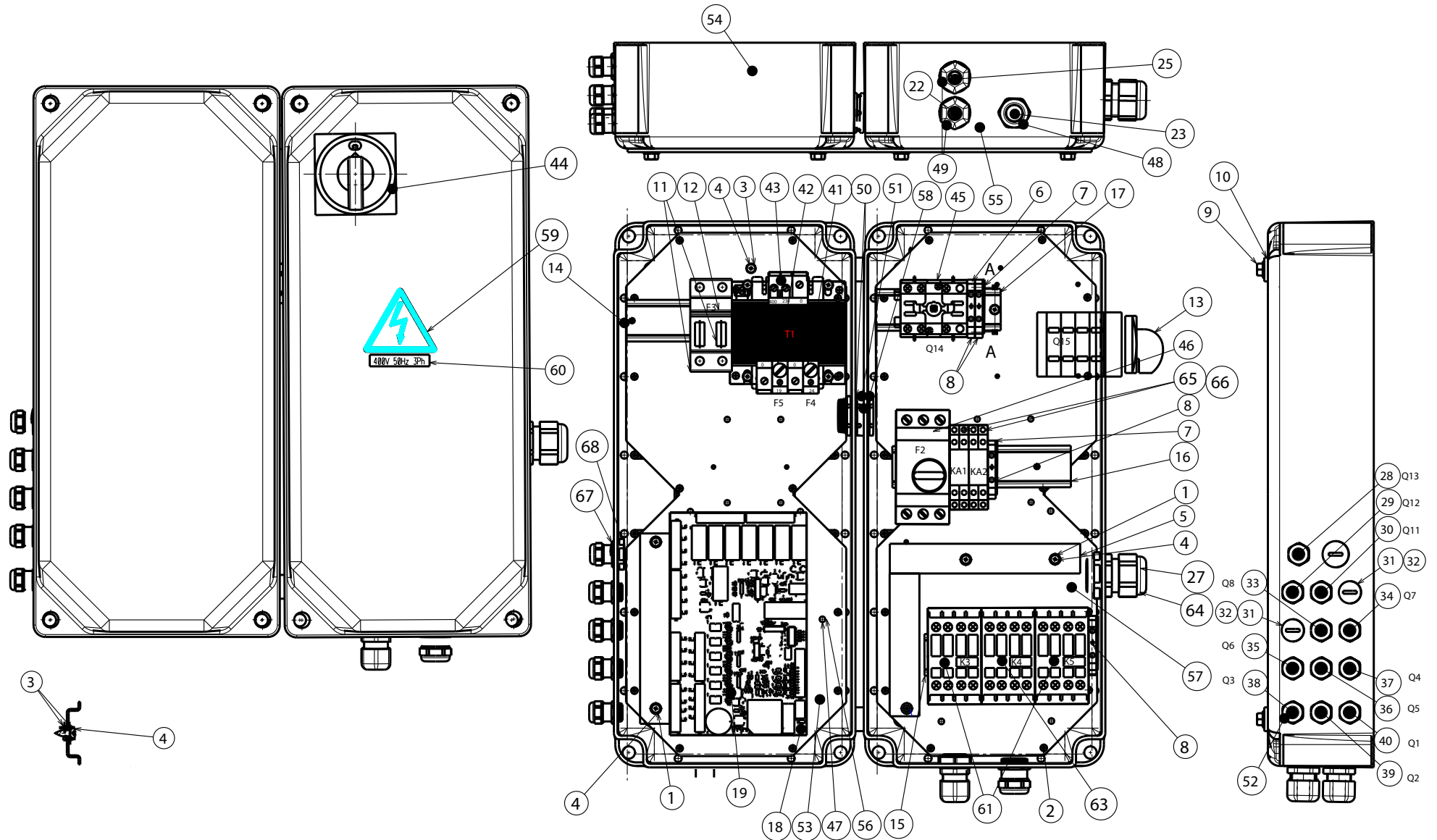



YV1	
YV2	YV8
YV3	YV9
YV4	YV10
YV5	YV11
YV6	YV12
YV7	YV13

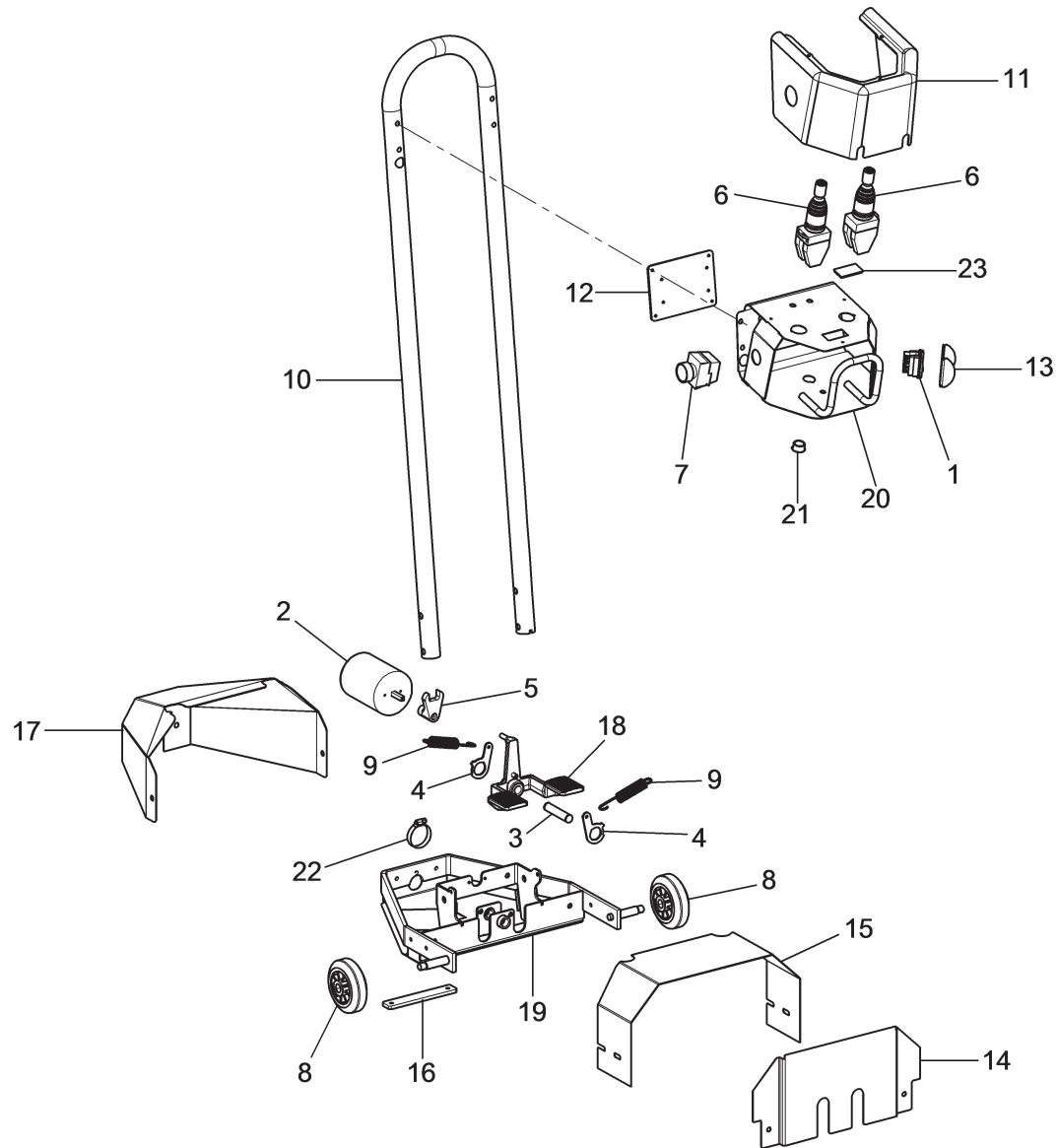
G9256.11SL	G9256.11ST	G9256.15	G9256T.15	G9256A.15	G9256D.15	G9256TD.15	G9256.15SL	G10360.15	G10360T.15	G10360A.15	G10360D.15	G10360TD.15						
		VAR	VAR	•				VAR	VAR	•								
 RAVAGLIOLI S.p.A.		LISTA DEI COMPONENTI - LIST OF COMPONENTS - TEILELISTE LISTE DES PIÈCES DÉTACHÉES - LISTA DE PIEZAS							MTG CASSETTA ELETTRICA ELECTRIC BOX MTG MTG ELEKTRISCHEKISTE MTG BOÏTER ELECTRIQUE MTG CAJITA ELECTRICA			Pag. 45 di 76						
		Tavola N°37 - Rev. 2				752203110												



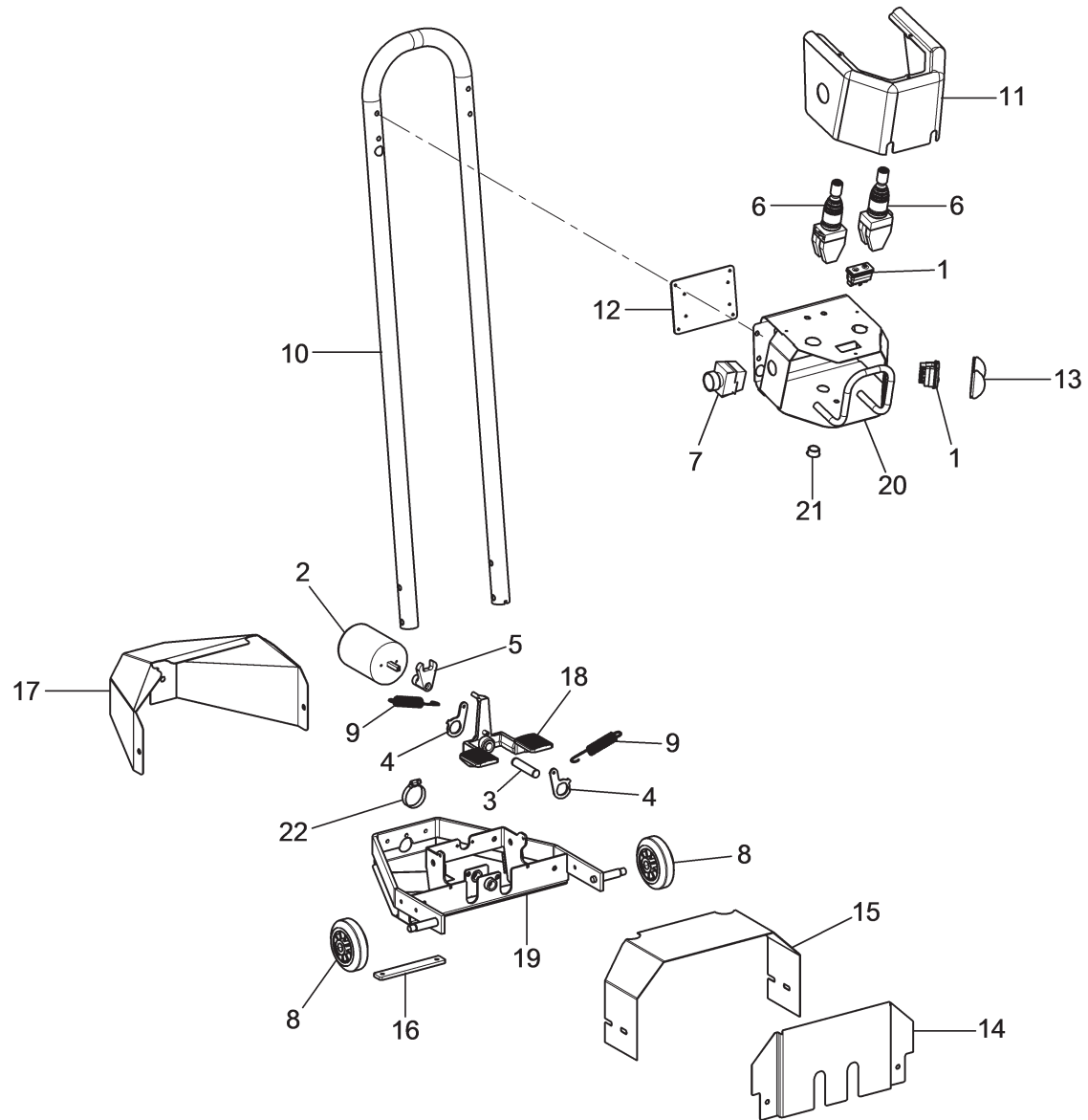
G9256.11SL	G9256.11ST	G9256.15	G9256T.15	G9256A.15	G9256D.15	G9256TD.15	G9256.15SL	G10360.15	G10360T.15	G10360A.15	G10360D.15	G10360TD.15									
					•	•					•	•									
 RAVAGLIOLI S.p.A.			LISTA DEI COMPONENTI - LIST OF COMPONENTS - TEILELISTE LISTE DES PIÈCES DÉTACHÉES - LISTA DE PIEZAS					Tavola N°38 - Rev. 2					752203250					Pag. 46 di 76			
												MTG CASSETTE ELETTRICHE MTG ELECTRICAL BOXES ELEKTRISCHEKISTEN MTG BOÎTES ÉLECTRIQUES MTG CAJITAS ELÉCTRICAS MTG									



G9256.11SL	G9256.11ST	G9256.15	G9256T.15	G9256A.15	G9256D.15	G9256TD.15	G9256.15SL	G10360.15	G10360T.15	G10360A.15	G10360D.15	G10360TD.15						
							VAR											
 RAVAGLIOLI S.p.A.		LISTA DEI COMPONENTI - LIST OF COMPONENTS - TEILELISTE LISTE DES PIÈCES DÉTACHÉES - LISTA DE PIEZAS							INSIEME MTG CASSETTA ELETTRICA ELECTRICAL BOX MTG ASSEMBLY SATZ MTG ELEKTRISCHERKISTE ASSEMBLAGE MTG BOÏTER ÉLECTRIQUE CONJUNTO MTG CAJITA ELECTRICA					Pag. 48 di 76				
		Tavola N°40 - Rev. 0				752203140												



G9256.11SL	G9256.11ST	G9256.15	G9256T.15	G9256A.15	G9256D.15	G9256TD.15	G9256.15SL	G10360.15	G10360T.15	G10360A.15	G10360D.15	G10360TD.15					
•							•										
 RAVAGLIOLI S.p.A.		LISTA DEI COMPONENTI - LIST OF COMPONENTS - TEILELISTE LISTE DES PIÈCES DÉTACHÉES - LISTA DE PIEZAS						GRUPPO MANIPOLATORE HANDLE UNIT MANIPULATORSATZ GROUPE MANIPULATEUR GRUPO MANIPULADOR					Pag. 49 di 76				
		Tavola N°41 - Rev. 2						752293230									



G9256.11SL	G9256.11ST	G9256.15	G9256T.15	G9256A.15	G9256D.15	G9256TD.15	G9256.15SL	G10360.15	G10360T.15	G10360A.15	G10360D.15	G10360TD.15				
		•	•		•	•		•	•		•	•				



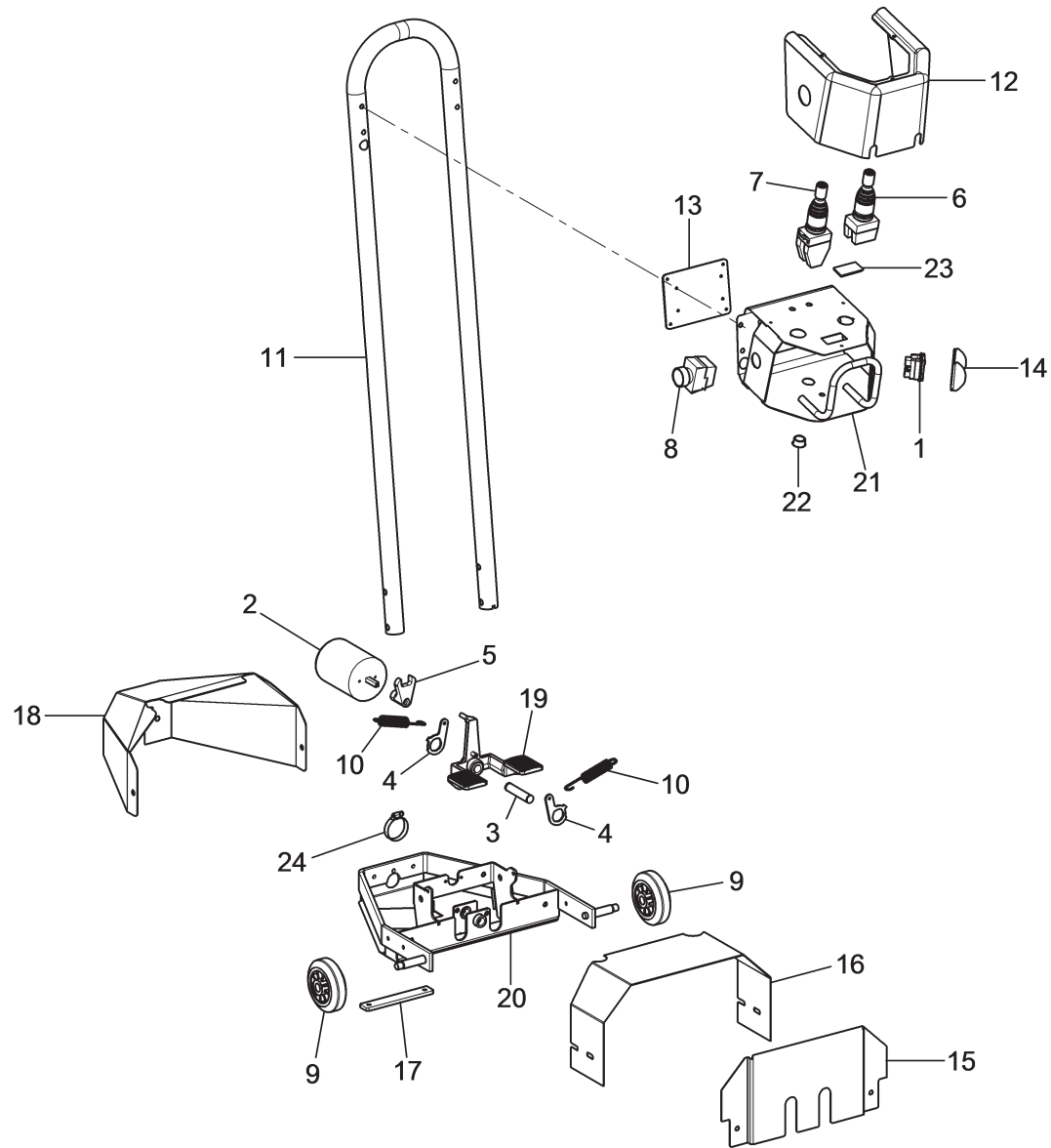
**LISTA DEI COMPONENTI - LIST OF COMPONENTS - TEILELISTE
LISTE DES PIÈCES DÉTACHÉES - LISTA DE PIEZAS**


Tavola N°42 - Rev. 6

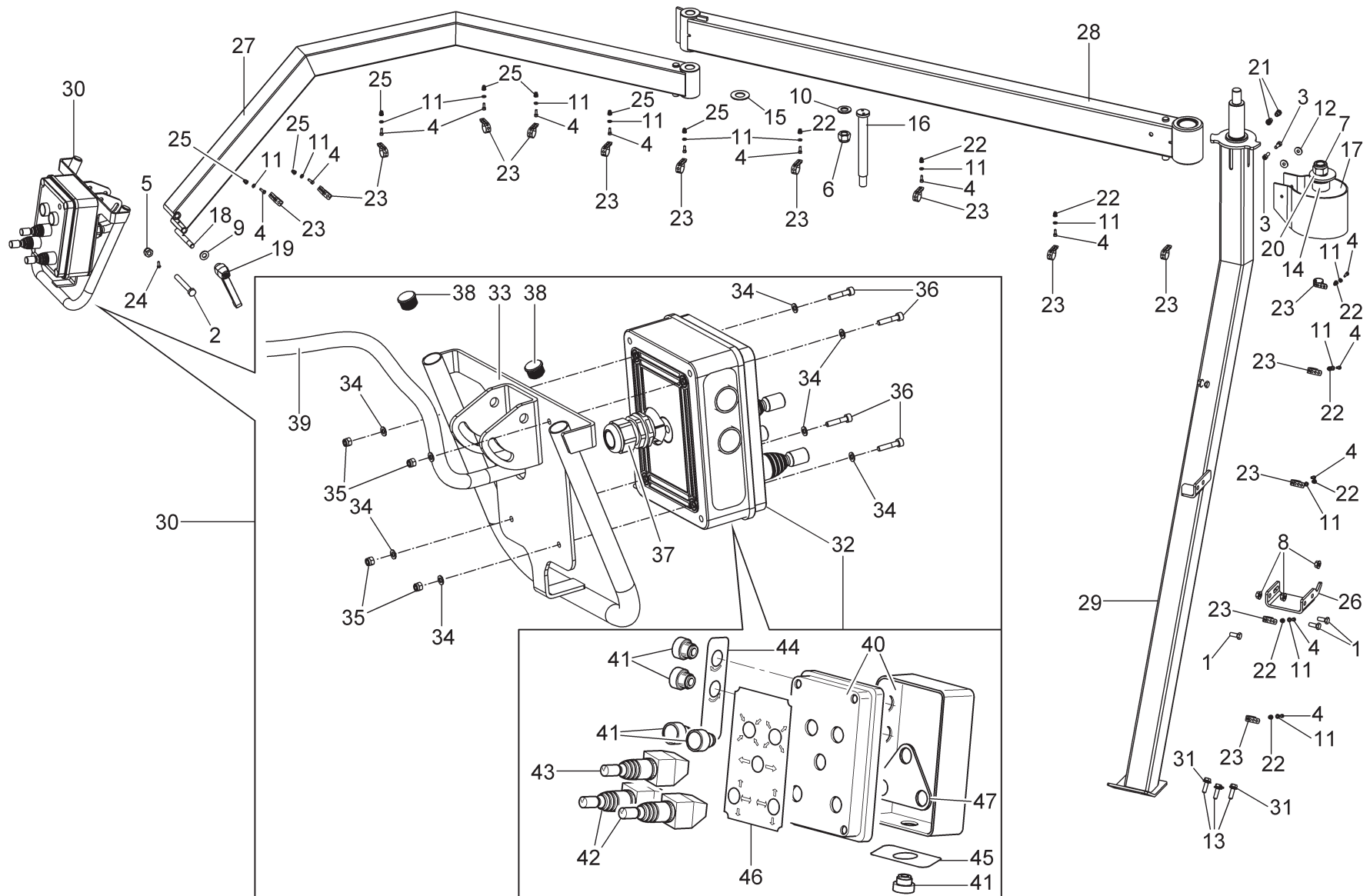
752293220

GRUPPO MANIPOLATORE
HANDLE UNIT
MANIPULATORSATZ
GROUPE MANIPULATEUR
GRUPO MANIPULADOR

Pag. 50 di 76



G9256.11SL	G9256.11ST	G9256.15	G9256T.15	G9256A.15	G9256D.15	G9256TD.15	G9256.15SL	G10360.15	G10360T.15	G10360A.15	G10360D.15	G10360TD.15					
	•																
 RAVAGLIOLI S.p.A.		LISTA DEI COMPONENTI - LIST OF COMPONENTS - TEILELISTE LISTE DES PIÈCES DÉTACHÉES - LISTA DE PIEZAS						GRUPPO MANIPOLATORE HANDLE UNIT MANIPULATORSATZ GROUPE MANIPULATEUR GRUPO MANIPULADOR					Pag. 51 di 76				
		Tavola N°43 - Rev. 4						752293240									



G9256.11SL	G9256.11ST	G9256.15	G9256T.15	G9256A.15	G9256D.15	G9256TD.15	G9256.15SL	G10360.15	G10360T.15	G10360A.15	G10360D.15	G10360TD.15					
		VAR	VAR	•													



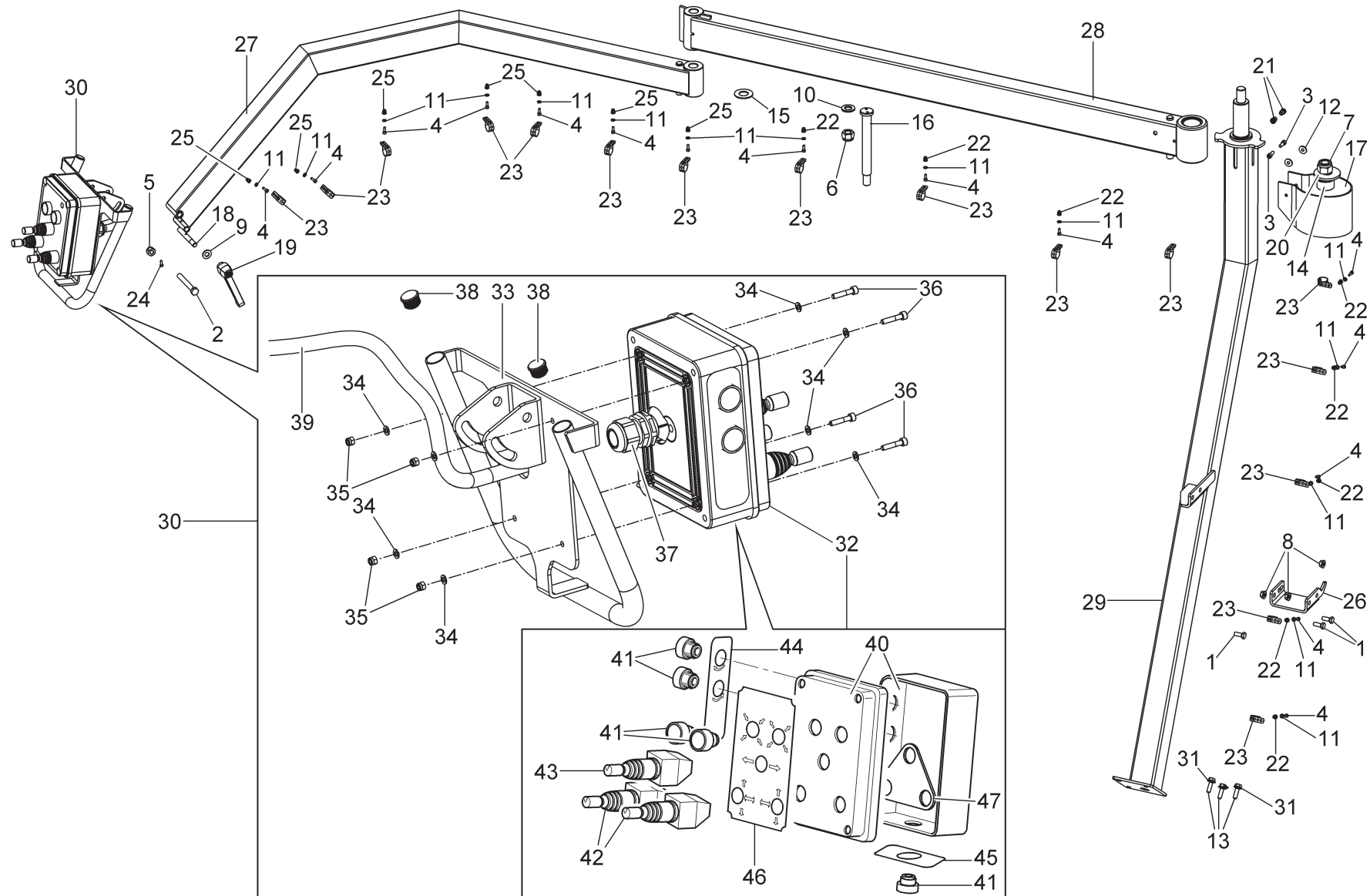
**LISTA DEI COMPONENTI - LIST OF COMPONENTS - TEILELISTE
LISTE DES PIÈCES DÉTACHÉES - LISTA DE PIEZAS**

Tavola N°44 - Rev. 0

752292150

MANIPOLATORE IN ARIA
AIR HANDLE
MANIPULATOR IN DER LUFT
MANIPULATEUR EN AIR
MANIPULADOR EN AIRE

Pag. 52 di 76



G9256.11SL	G9256.11ST	G9256.15	G9256T.15	G9256A.15	G9256D.15	G9256TD.15	G9256.15SL	G10360.15	G10360T.15	G10360A.15	G10360D.15	G10360TD.15					
								VAR	VAR	•	VAR	VAR					



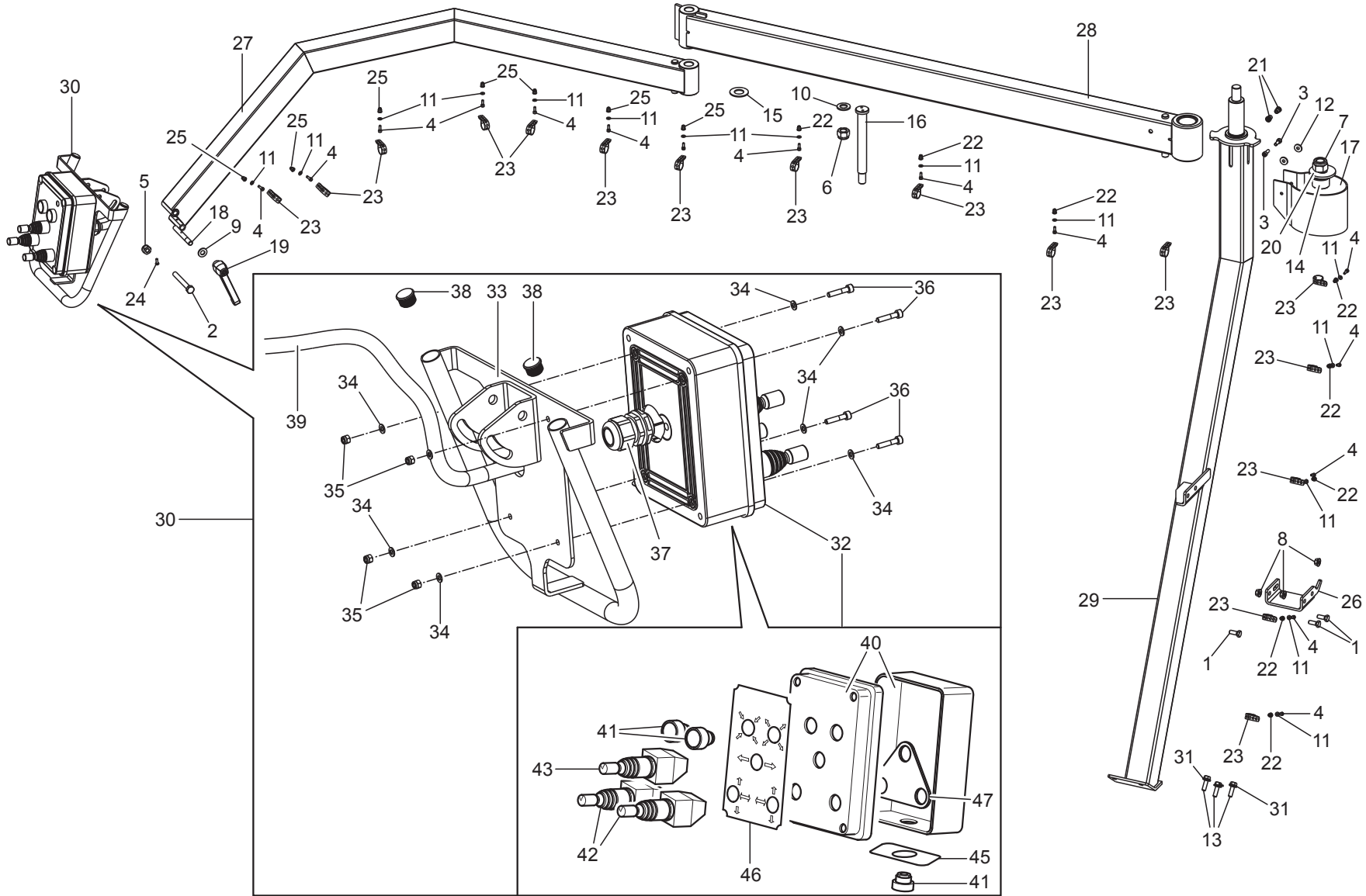
LISTA DEI COMPONENTI - LIST OF COMPONENTS - TEILELISTE
LISTE DES PIÈCES DÉTACHÉES - LISTA DE PIEZAS

Tavola N°45 - Rev. 0

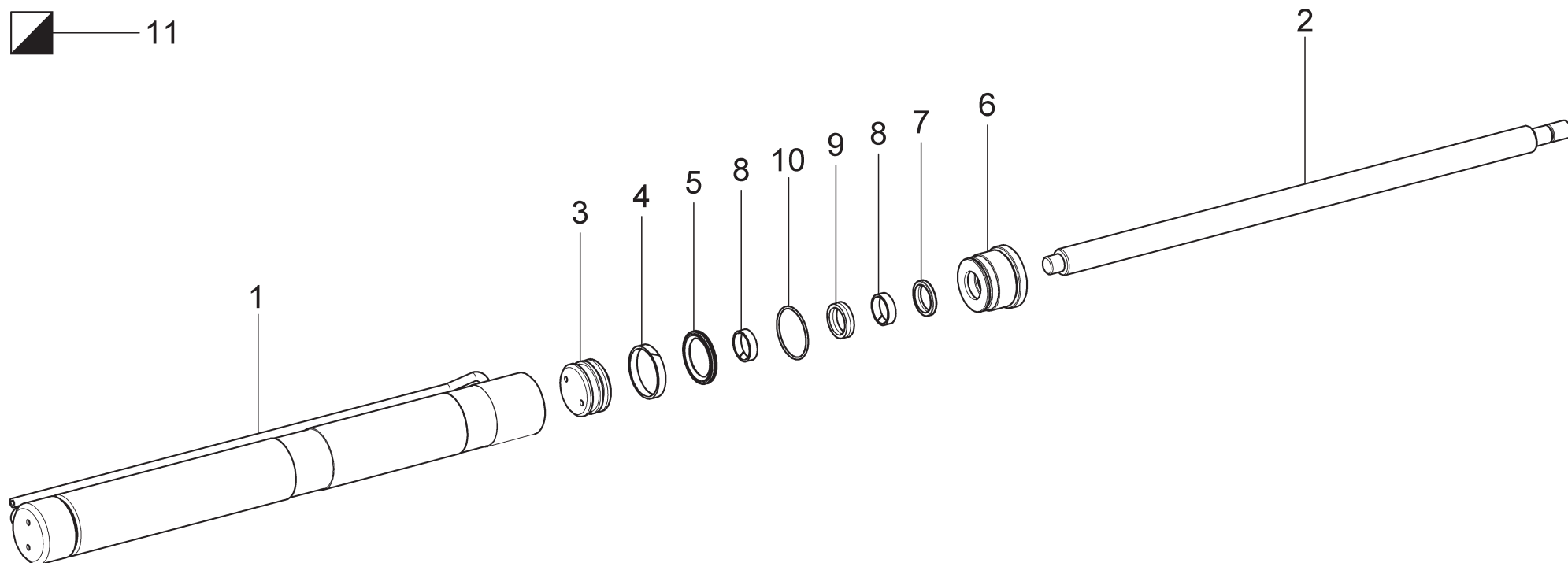
752291360

MANIPOLATORE IN ARIA
 AIR HANDLE
 MANIPULATOR IN DER LUFT
 MANIPULATEUR EN AIR
 MANIPULADOR EN AIRE

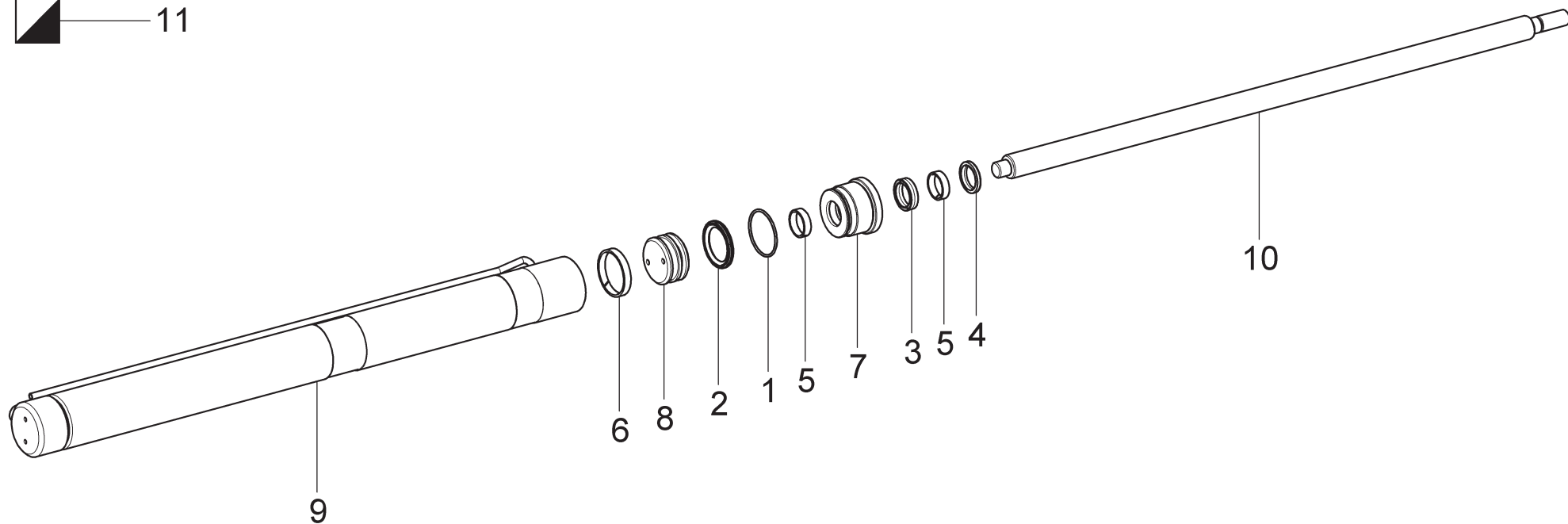
Pag. 53 di 76



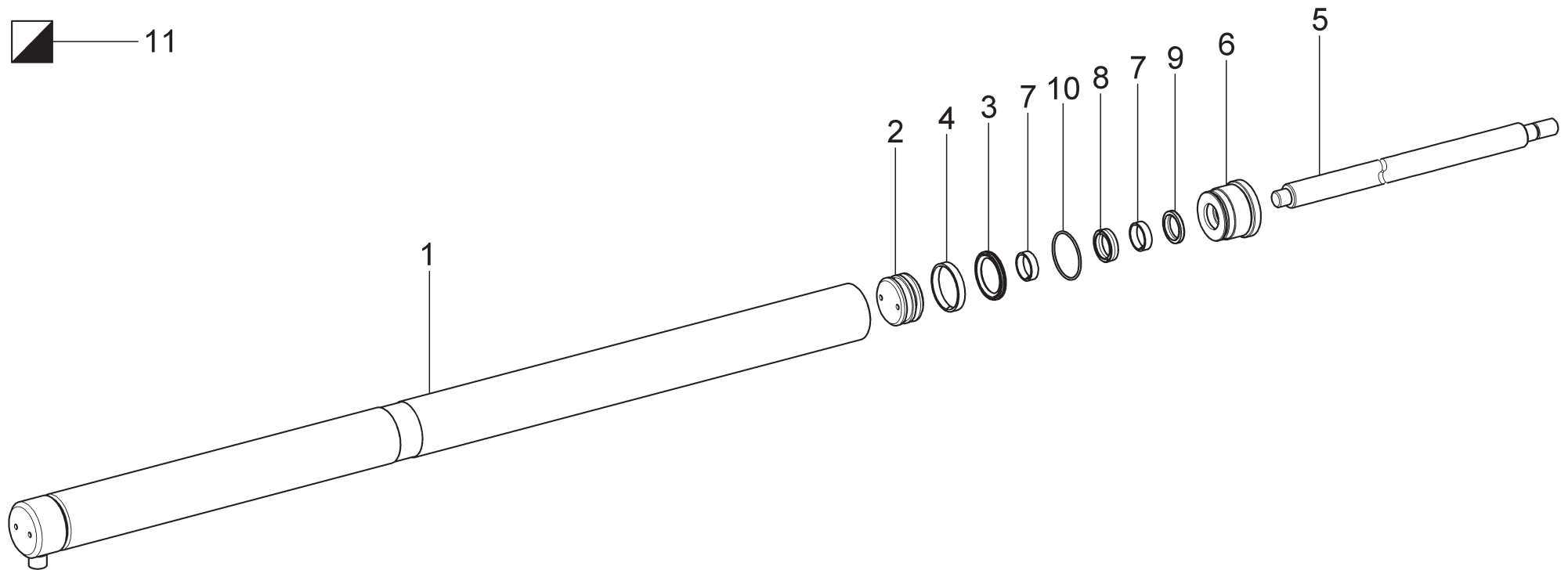
G9256.11SL	G9256.11ST	G9256.15	G9256T.15	G9256A.15	G9256D.15	G9256TD.15	G9256.15SL	G10360.15	G10360T.15	G10360A.15	G10360D.15	G10360TD.15															
VAR							VAR																				
 RAVAGLIOLI S.p.A.		LISTA DEI COMPONENTI - LIST OF COMPONENTS - TEILELISTE LISTE DES PIÈCES DÉTACHÉES - LISTA DE PIEZAS						Tavola N°46 - Rev. 0						752292690						MANIPOLATORE IN ARIA AIR HANDLE MANIPULATOR IN DER LUFT MANIPULATEUR EN AIR MANIPULADOR EN AIRE				Pag. 54 di 76			



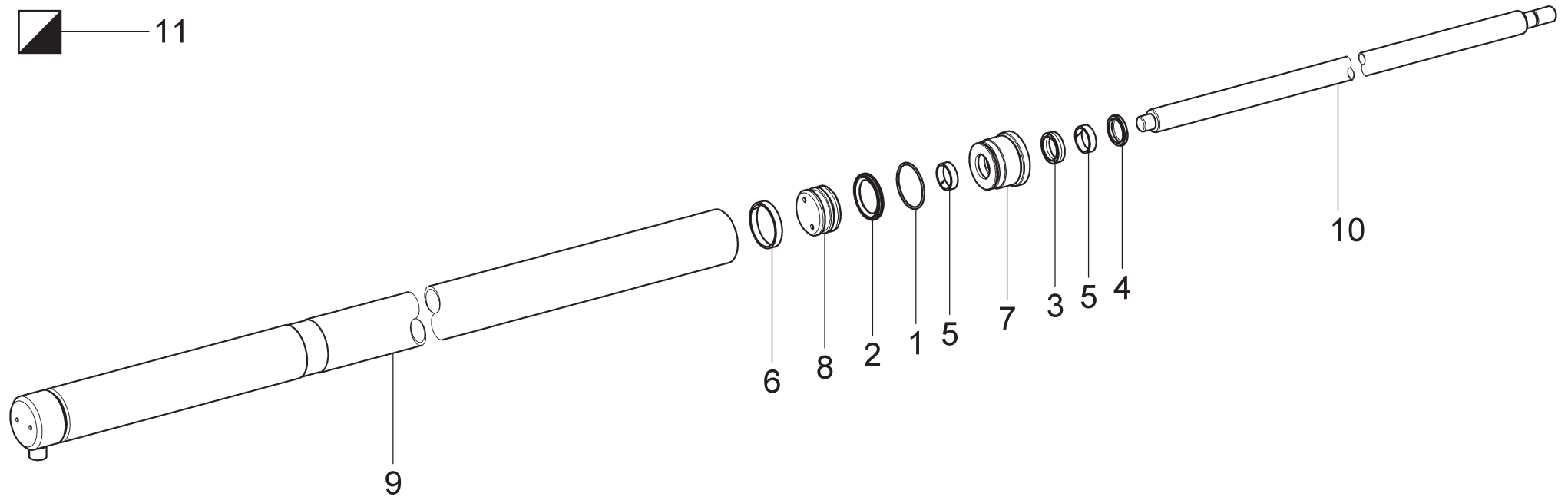
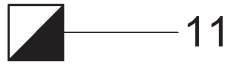
G9256.11SL	G9256.11ST	G9256.15	G9256T.15	G9256A.15	G9256D.15	G9256TD.15	G9256.15SL	G10360.15	G10360T.15	G10360A.15	G10360D.15	G10360TD.15					
•	•																
 RAVAGLIOLI S.p.A.		LISTA DEI COMPONENTI - LIST OF COMPONENTS - TEILELISTE LISTE DES PIÈCES DÉTACHÉES - LISTA DE PIEZAS						CILINDRO D.60 D.60 CYLINDER ZYLINDER D.60 CYLINDRE D.60 CILINDRO D.60					Pag. 55 di 76				
		Tavola N°47 - Rev. 1			752290690												



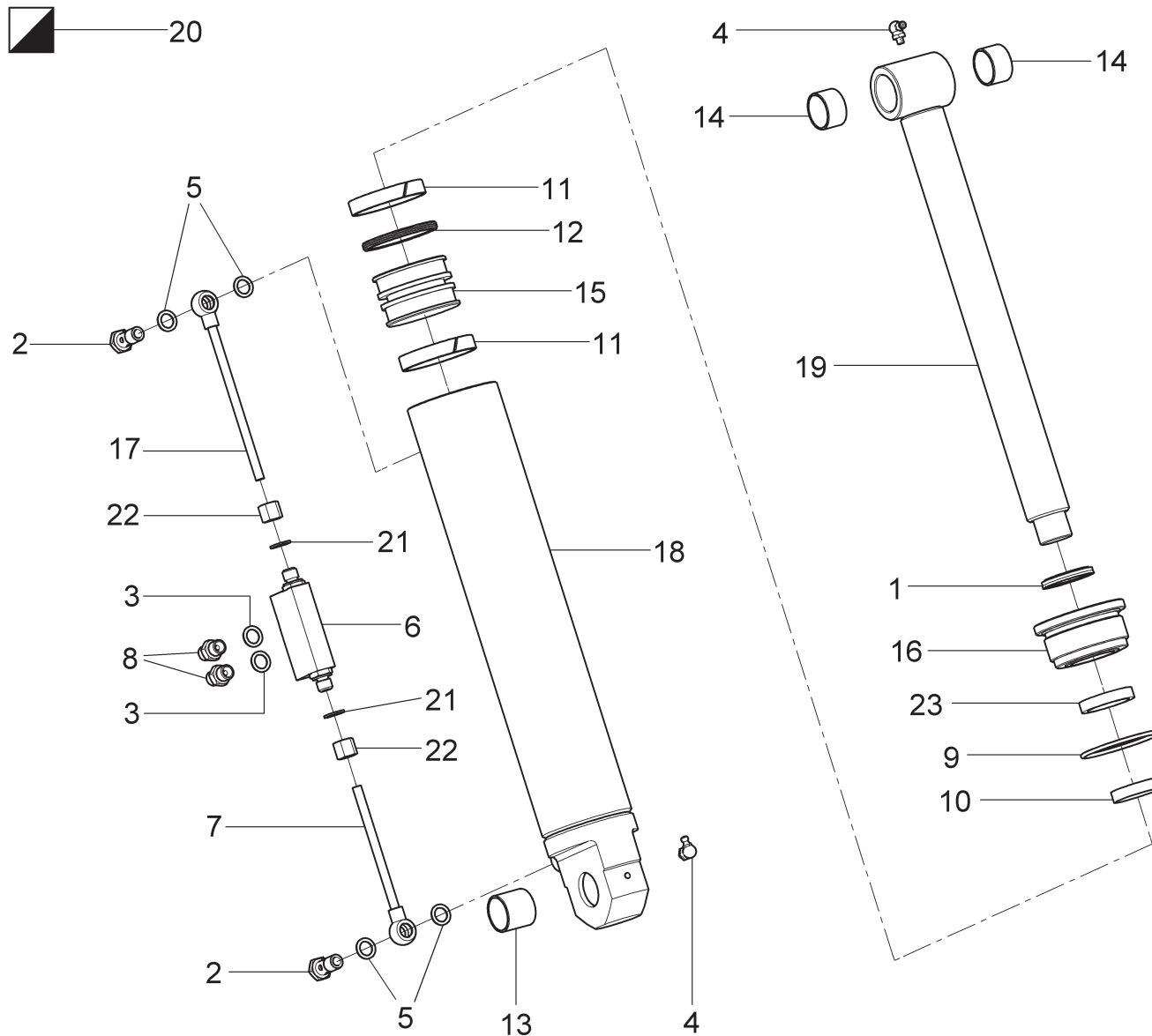
G9256.11SL	G9256.11ST	G9256.15	G9256T.15	G9256A.15	G9256D.15	G9256TD.15	G9256.15SL	G10360.15	G10360T.15	G10360A.15	G10360D.15	G10360TD.15				
		•	•	•	•	•	•									
 RAVAGLIOLI S.p.A.		LISTA DEI COMPONENTI - LIST OF COMPONENTS - TEILELISTE LISTE DES PIÈCES DÉTACHÉES - LISTA DE PIEZAS							CILINDRO D.60 D.60 CYLINDER ZYLINDER D.60 CYLINDRE D.60 CILINDRO D.60					Pag. 56 di 76		
		Tavola N°48 - Rev. 0		752290410												



G9256.11SL	G9256.11ST	G9256.15	G9256T.15	G9256A.15	G9256D.15	G9256TD.15	G9256.15SL	G10360.15	G10360T.15	G10360A.15	G10360D.15	G10360TD.15				
•	•															
 RAVAGLIOLI S.p.A.		LISTA DEI COMPONENTI - LIST OF COMPONENTS - TEILELISTE LISTE DES PIÈCES DÉTACHÉES - LISTA DE PIEZAS							CILINDRO D.60 D.60 CYLINDER ZYLINDER D.60 CYLINDRE D.60 CILINDRO D.60					Pag. 57 di 76		
		Tavola N°49 - Rev. 1		752290870												



G9256.11SL	G9256.11ST	G9256.15	G9256T.15	G9256A.15	G9256D.15	G9256TD.15	G9256.15SL	G10360.15	G10360T.15	G10360A.15	G10360D.15	G10360TD.15					
		•	•	•	•	•	•	•	•	•	•	•					
 RAVAGLIOLI S.p.A.		LISTA DEI COMPONENTI - LIST OF COMPONENTS - TEILELISTE LISTE DES PIÈCES DÉTACHÉES - LISTA DE PIEZAS								CILINDRO CARRO CARRIAGE CYLINDER WAGENZYLINDER CYLINDRE CHARIOT CILINDRO CARRO				Pag. 58 di 76			
		Tavola N°50 - Rev. 0				752290530											



G9256.11SL	G9256.11ST	G9256.15	G9256T.15	G9256A.15	G9256D.15	G9256TD.15	G9256.15SL	G10360.15	G10360T.15	G10360A.15	G10360D.15	G10360TD.15					
•	•	•	•	•	•	•	•										



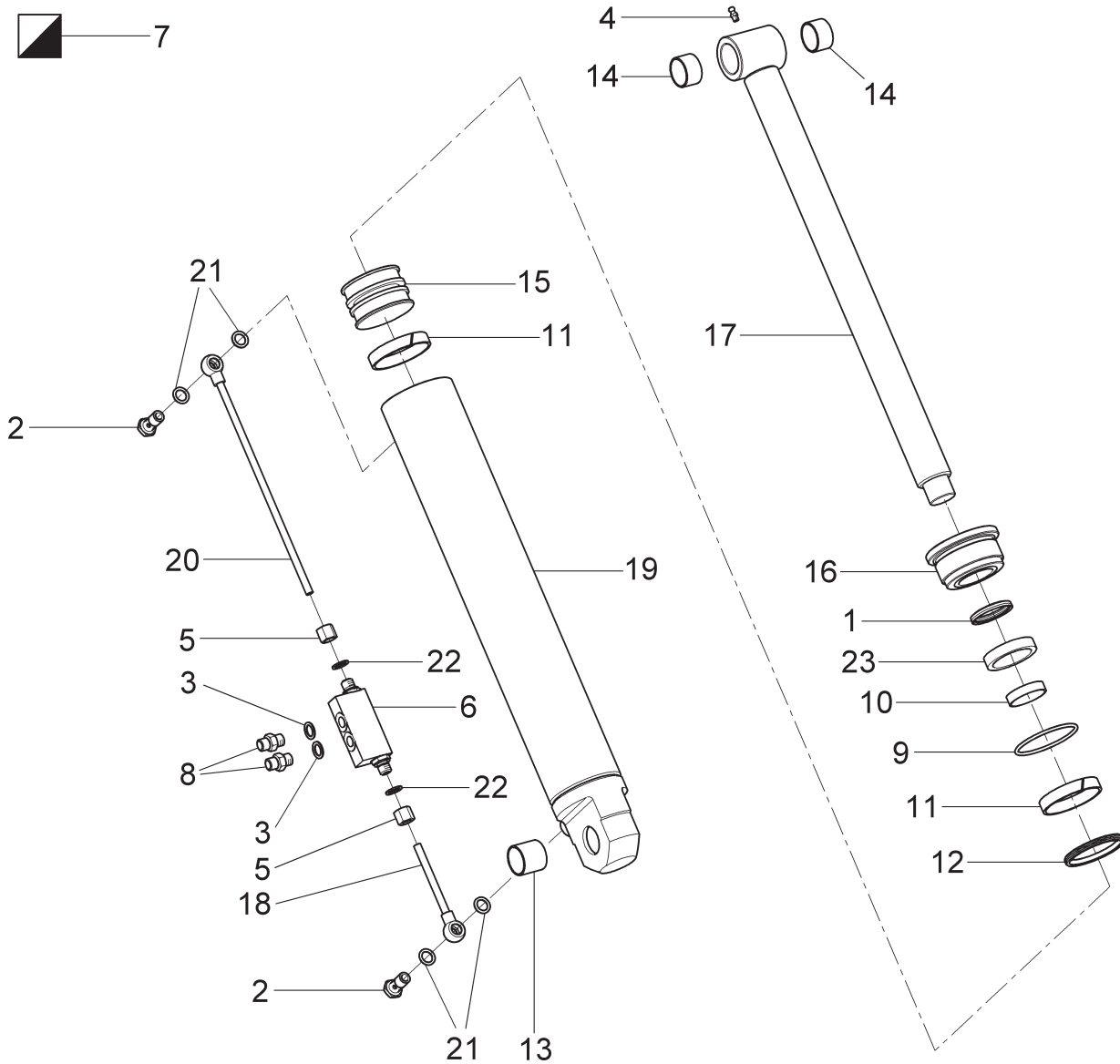
**LISTA DEI COMPONENTI - LIST OF COMPONENTS - TEILELISTE
LISTE DES PIÈCES DÉTACHÉES - LISTA DE PIEZAS**


Tavola N°51 - Rev. 2

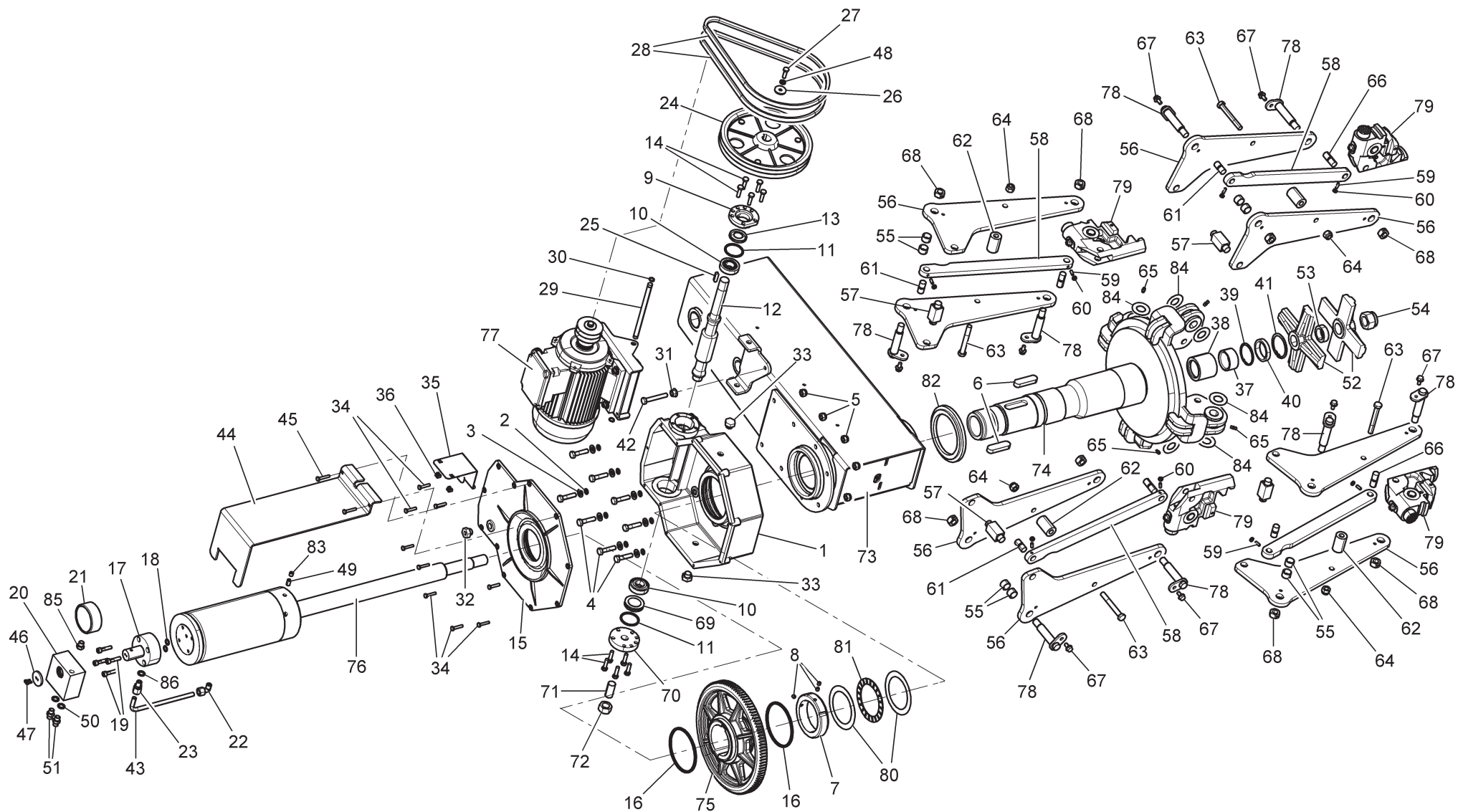
752290710

CILINDRO IDRAULICO D.70
D.70 HYDRAULIC CYLINDER
HYDRAULIKZYLINDER D.70
CYLINDRE HYDRAULIQUE D.70
CILINDRO HIDRÁULICO D.70

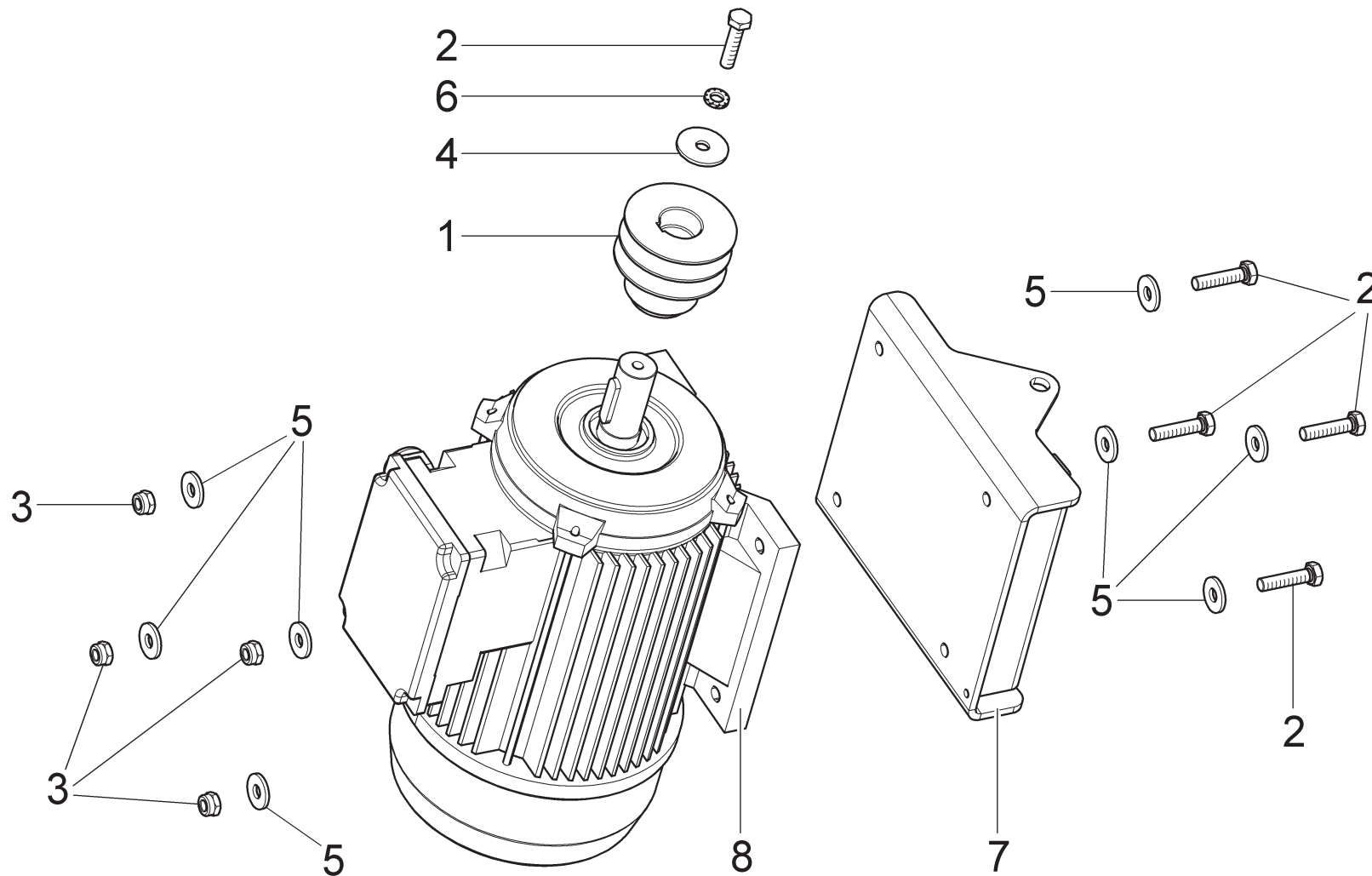
Pag. 59 di 76



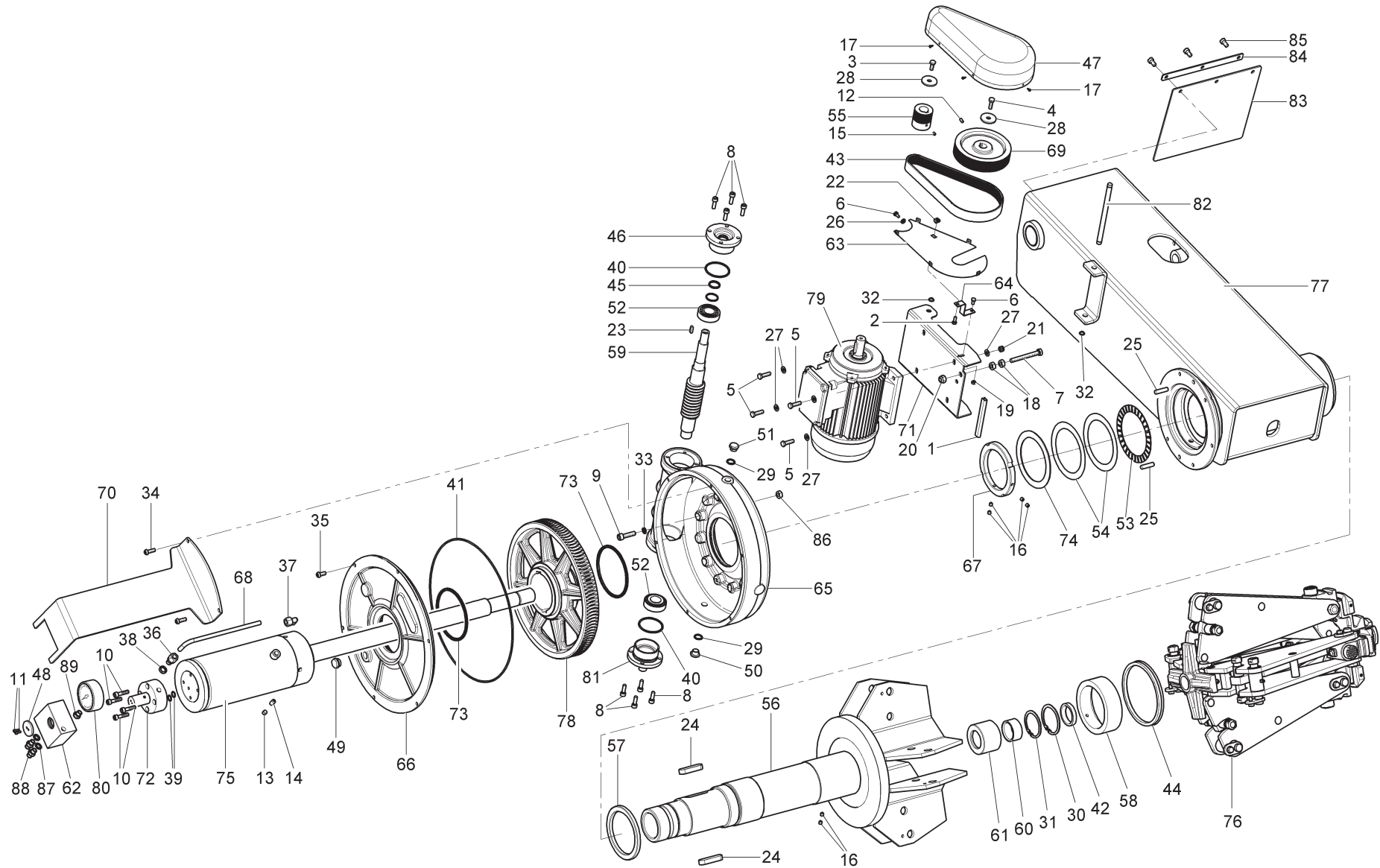
G9256.11SL	G9256.11ST	G9256.15	G9256T.15	G9256A.15	G9256D.15	G9256TD.15	G9256.15SL	G10360.15	G10360T.15	G10360A.15	G10360D.15	G10360TD.15				
								•	•	•	•	•				
 RAVAGLIOLI S.p.A.			LISTA DEI COMPONENTI - LIST OF COMPONENTS - TEILELISTE LISTE DES PIÈCES DÉTACHÉES - LISTA DE PIEZAS					CILINDRO D.70 D.70 CYLINDER ZYLINDER D.70 CYLINDRE D.70 CILINDRO D.70					Pag. 60 di 76			
			Tavola N°52 - Rev. 2		752290700											




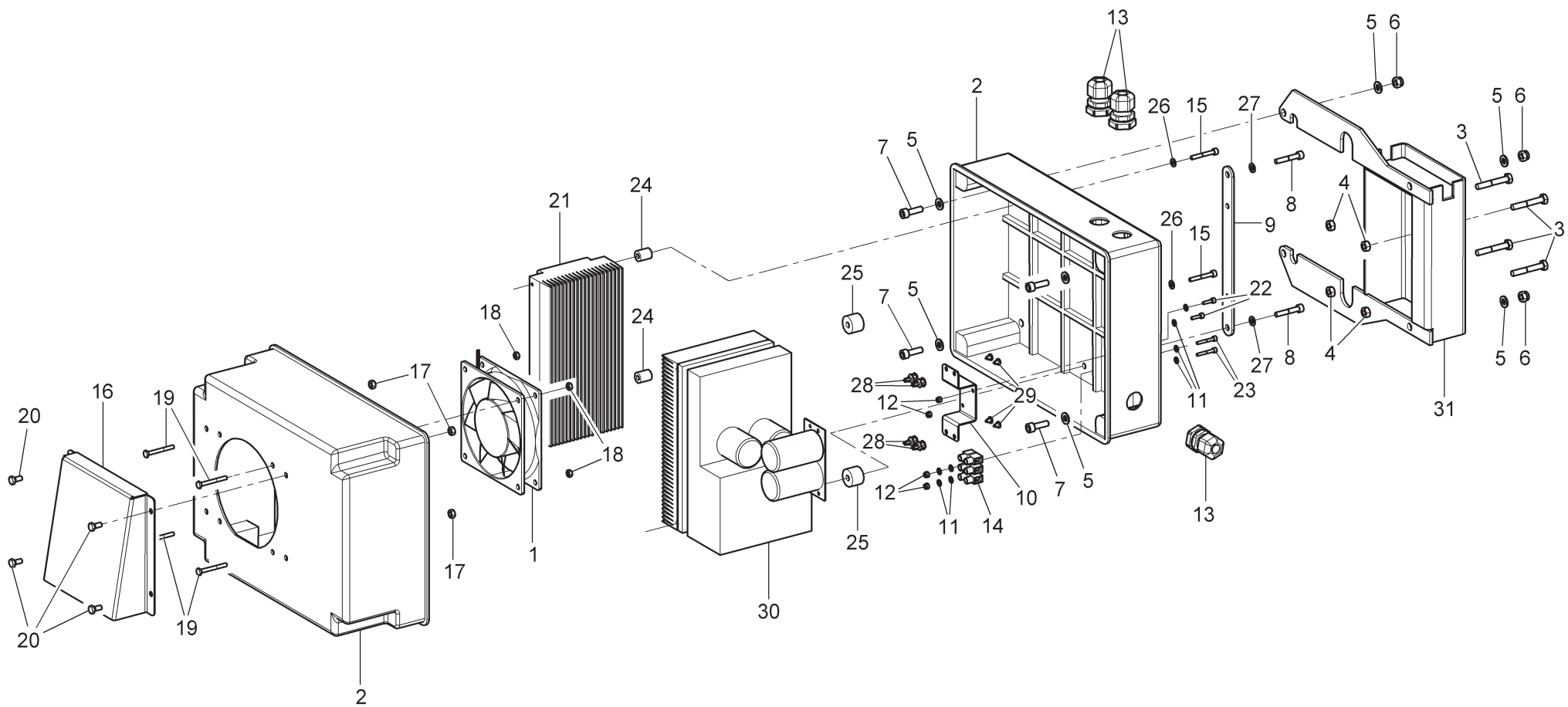
G9256.11SL	G9256.11ST	G9256.15	G9256T.15	G9256A.15	G9256D.15	G9256TD.15	G9256.15SL	G10360.15	G10360T.15	G10360A.15	G10360D.15	G10360TD.15																			
					•	•	VAR																								
 RAVAGLIOLI S.p.A.		LISTA DEI COMPONENTI - LIST OF COMPONENTS - TEILELISTE LISTE DES PIÈCES DETACHÉES - LISTA DE PIEZAS						Tavola N°53 - Rev. 1						752292120						BRACCIO MANDRINO INVERTER INVERTER MANDREL ARM SPINDELSARM VON FREQUENUMFORMER BRAS MANDRIN VARIATEUR BRAZO MANDRIL INVERSOR						Pag. 61 di 76					



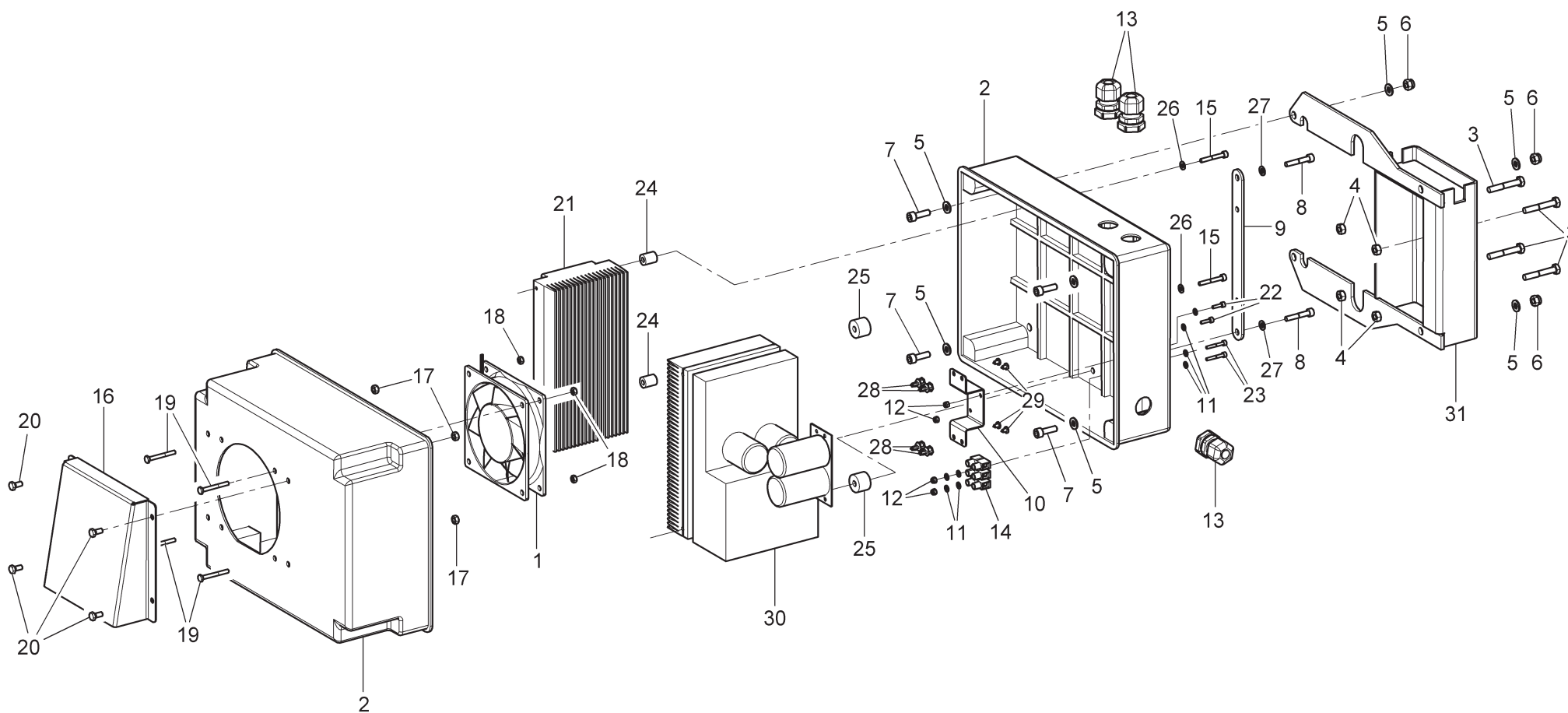
G9256.11SL	G9256.11ST	G9256.15	G9256T.15	G9256A.15	G9256D.15	G9256TD.15	G9256.15SL	G10360.15	G10360T.15	G10360A.15	G10360D.15	G10360TD.15					
					•	•	VAR										
 RAVAGLIOLI S.p.A.		LISTA DEI COMPONENTI - LIST OF COMPONENTS - TEILELISTE LISTE DES PIÈCES DÉTACHÉES - LISTA DE PIEZAS						GRUPPO MOTORE ELETTRICO ELECTRIC MOTOR UNIT ELEKTRISCHER MOTORSATZ GROUPE MOTEUR ÉLECTRIQUE GRUPO MOTOR ELÉCTRICO					Pag. 62 di 76				
		Tavola N°54 - Rev. 0			752292130												



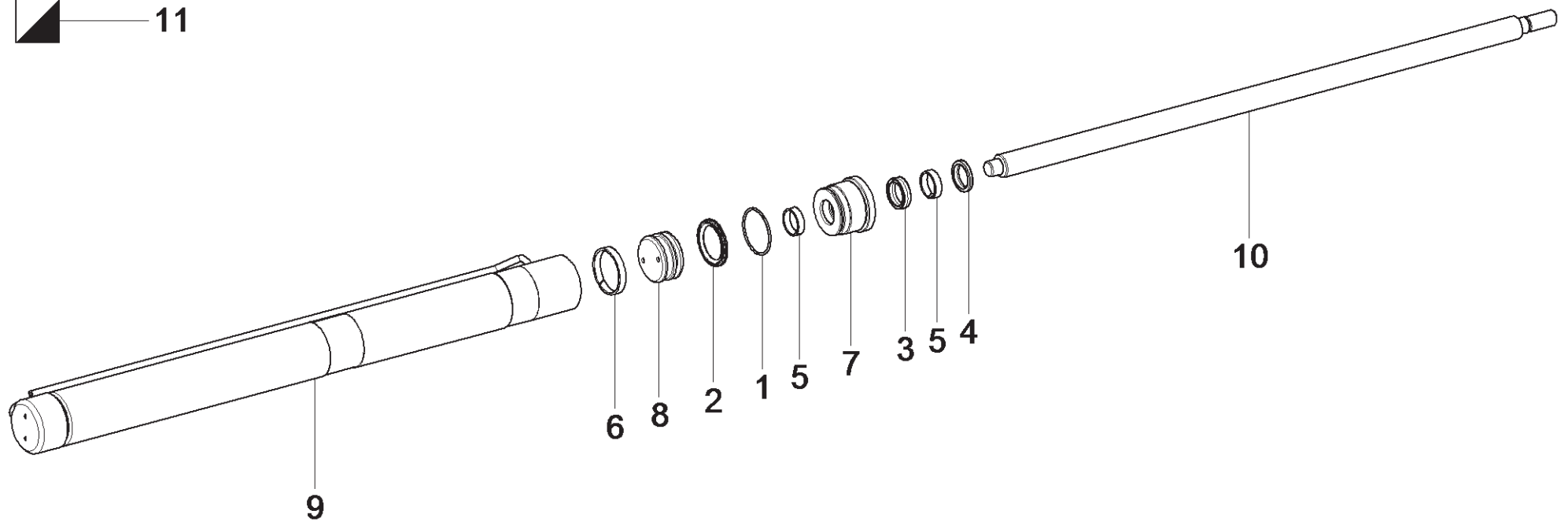
G9256.11SL	G9256.11ST	G9256.15	G9256T.15	G9256A.15	G9256D.15	G9256TD.15	G9256.15SL	G10360.15	G10360T.15	G10360A.15	G10360D.15	G10360TD.15				
											•	•				
 RAVAGLIOLI S.p.A.		LISTA DEI COMPONENTI - LIST OF COMPONENTS - TEILELISTE LISTE DES PIÈCES DÉTACHÉES - LISTA DE PIEZAS						BRACCIO MANDRINO INVERTER INVERTER MANDREL ARM SPINDELSARM VON FREQUENUMFORMER BRAS MANDRIN VARIATEUR BRAZO MANDRIL INVERSOR					Pag. 63 di 76			
		Tavola N°55 - Rev. 1						752292140								



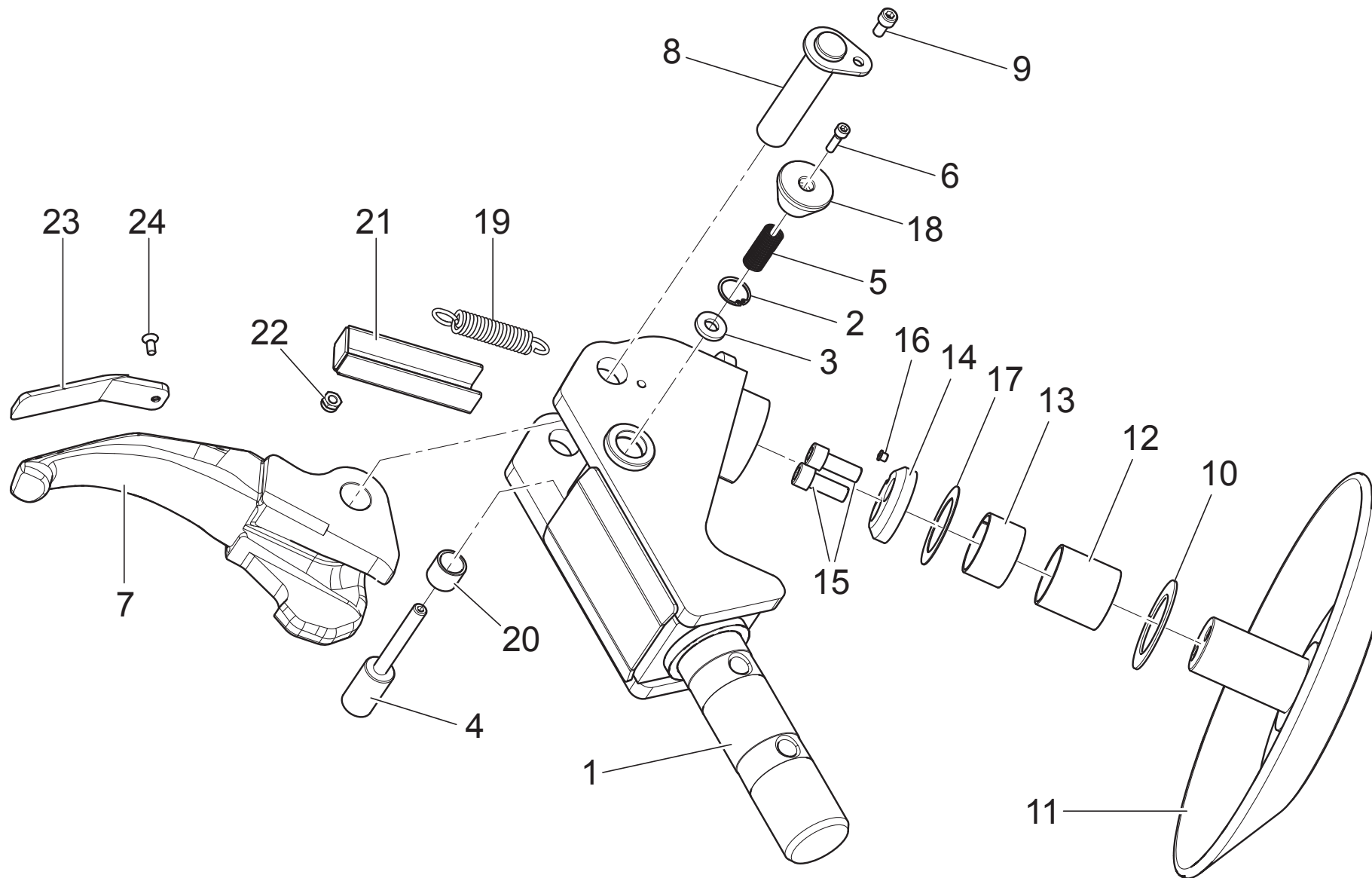
G9256.11SL	G9256.11ST	G9256.15	G9256T.15	G9256A.15	G9256D.15	G9256TD.15	G9256.15SL	G10360.15	G10360T.15	G10360A.15	G10360D.15	G10360TD.15					
					•	•											
 RAVAGLIOLI S.p.A.			LISTA DEI COMPONENTI - LIST OF COMPONENTS - TEILELISTE LISTE DES PIÈCES DÉTACHÉES - LISTA DE PIEZAS								GRUPPO INVERTER INVERTER UNIT FREQUENZUMFORMERSATZ GROUPE VARIATEUR GRUPO INVERSOR				Pag. 64 di 76		
			Tavola N°56 - Rev. 0				752292100										



G9256.11SL	G9256.11ST	G9256.15	G9256T.15	G9256A.15	G9256D.15	G9256TD.15	G9256.15SL	G10360.15	G10360T.15	G10360A.15	G10360D.15	G10360TD.15				
											•	•				
 RAVAGLIOLI S.p.A.		LISTA DEI COMPONENTI - LIST OF COMPONENTS - TEILELISTE LISTE DES PIÈCES DÉTACHÉES - LISTA DE PIEZAS						GRUPPO INVERTER INVERTER UNIT FREQUENZUMFORMERSATZ GROUPE VARIATEUR GRUPO INVERSOR					Pag. 65 di 76			
		Tavola N°57 - Rev. 0			752292070											



G9256.11SL	G9256.11ST	G9256.15	G9256T.15	G9256A.15	G9256D.15	G9256TD.15	G9256.15SL	G10360.15	G10360T.15	G10360A.15	G10360D.15	G10360TD.15					
								•	•	•	•	•					
 RAVAGLIOLI S.p.A.		LISTA DEI COMPONENTI - LIST OF COMPONENTS - TEILELISTE LISTE DES PIÈCES DÉTACHÉES - LISTA DE PIEZAS						CILINDRO D.60 D.60 CYLINDER ZYLINDER D.60 CYLINDRE D.60 CILINDRO D.60					Pag. 66 di 76				
		Tavola N°58 - Rev. 0			752292190												



G9256.11SL	G9256.11ST	G9256.15	G9256T.15	G9256A.15	G9256D.15	G9256TD.15	G9256.15SL	G10360.15	G10360T.15	G10360A.15	G10360D.15	G10360TD.15						
			•			•												



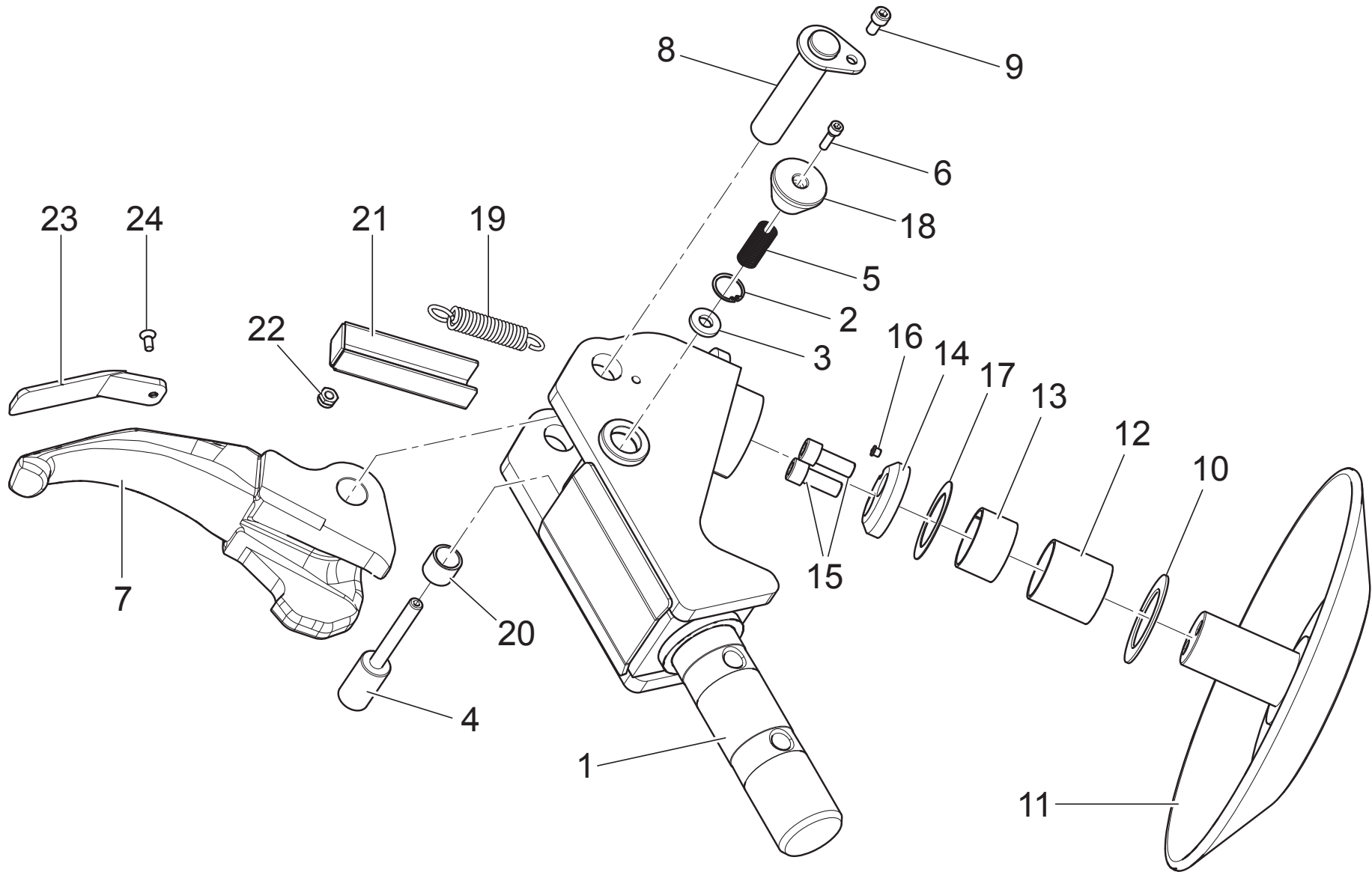
**LISTA DEI COMPONENTI - LIST OF COMPONENTS - TEILELISTE
LISTE DES PIÈCES DÉTACHÉES - LISTA DE PIEZAS**


Tavola N°59 - Rev. 0

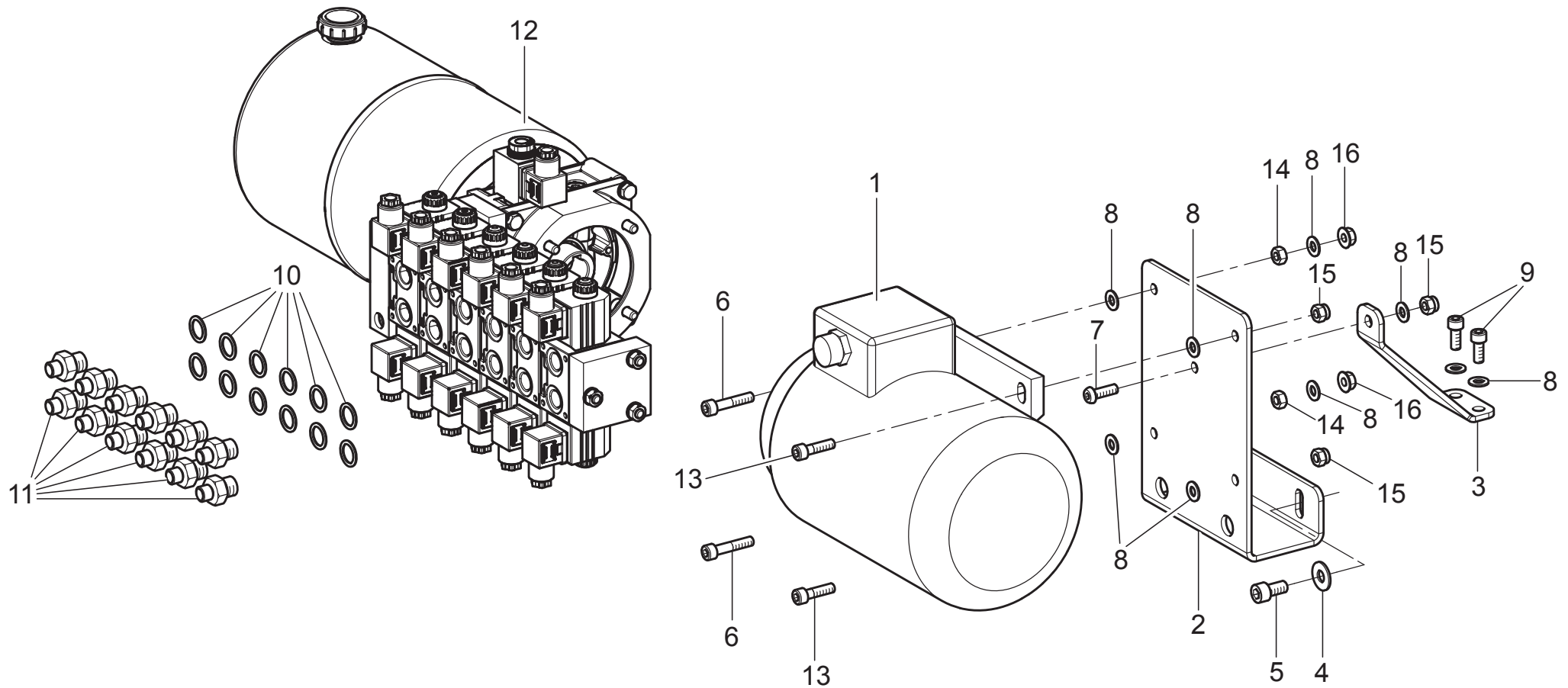
752292290

GRUPPO UTENSILI SENZA LEVA
TOOLS UNIT WITHOUT LEVER
WERKZEUGSATZ OHNE HEBEL
GROUPE OUTILS SANS LEVIER
GRUPO UTENSILIOS SINE PALANCA

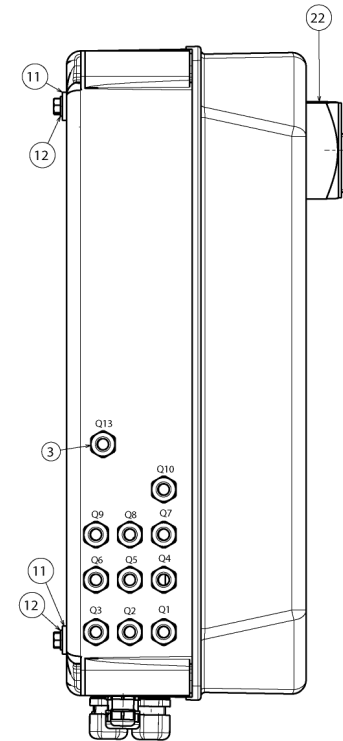
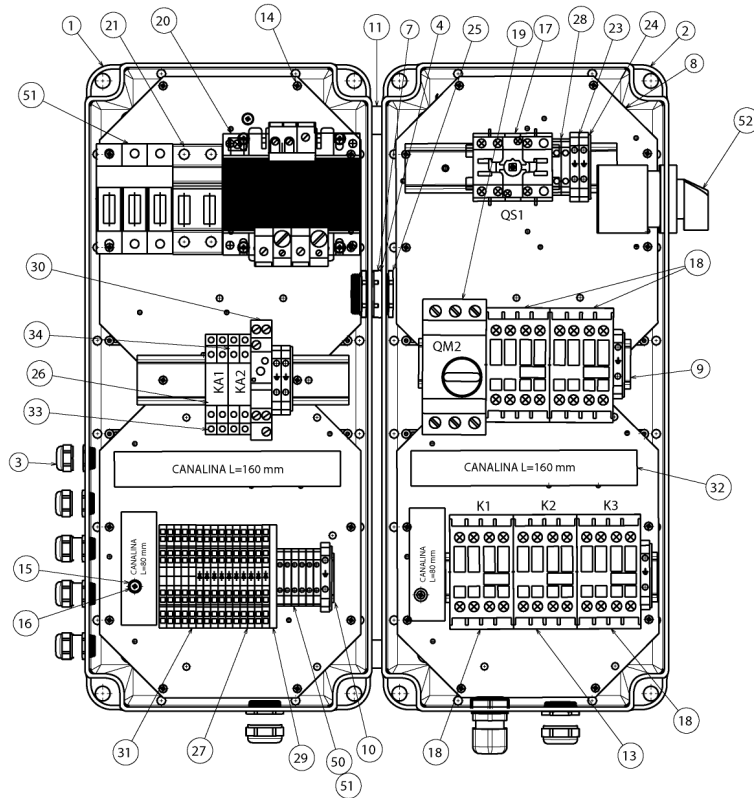
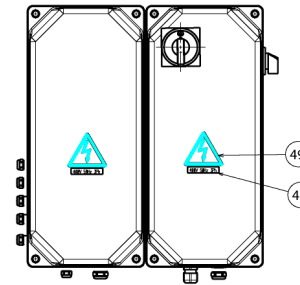
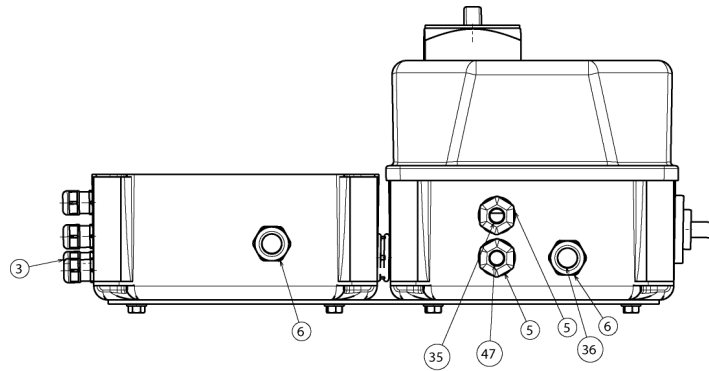
Pag. 67 di 76



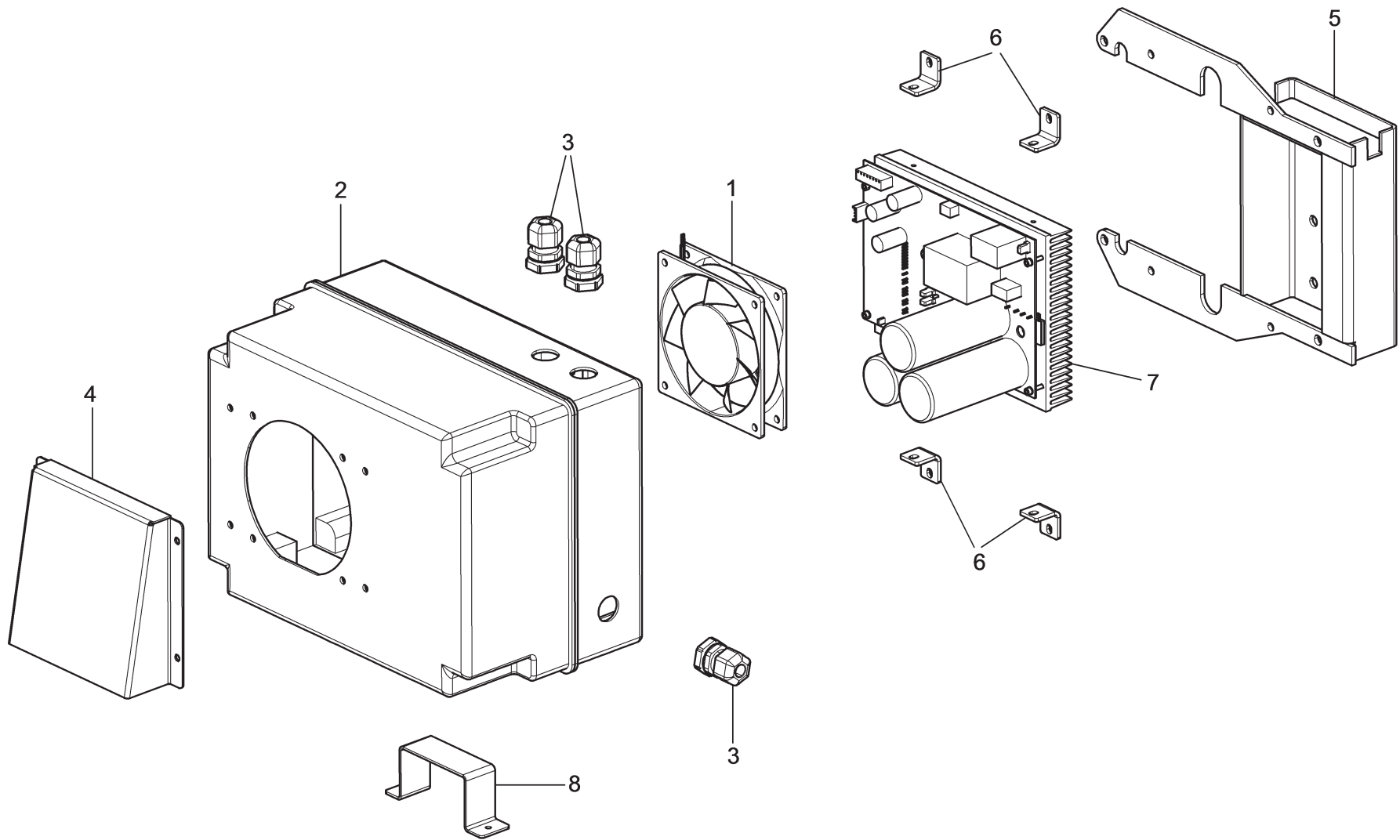
G9256.11SL	G9256.11ST	G9256.15	G9256T.15	G9256A.15	G9256D.15	G9256TD.15	G9256.15SL	G10360.15	G10360T.15	G10360A.15	G10360D.15	G10360TD.15						
									•			•						
 RAVAGLIOLI S.p.A.		LISTA DEI COMPONENTI - LIST OF COMPONENTS - TEILELISTE LISTE DES PIÈCES DÉTACHÉES - LISTA DE PIEZAS							GRUPPO UTENSILI SENZA LEVA TOOLS UNIT WITHOUT LEVER WERKZEUGSATZ OHNE HEBEL GROUPE OUTILS SANS LEVIER GRUPO UTENSILIOS SINE PALANCA					Pag. 68 di 76				
		Tavola N°60 - Rev. 0				752292340												



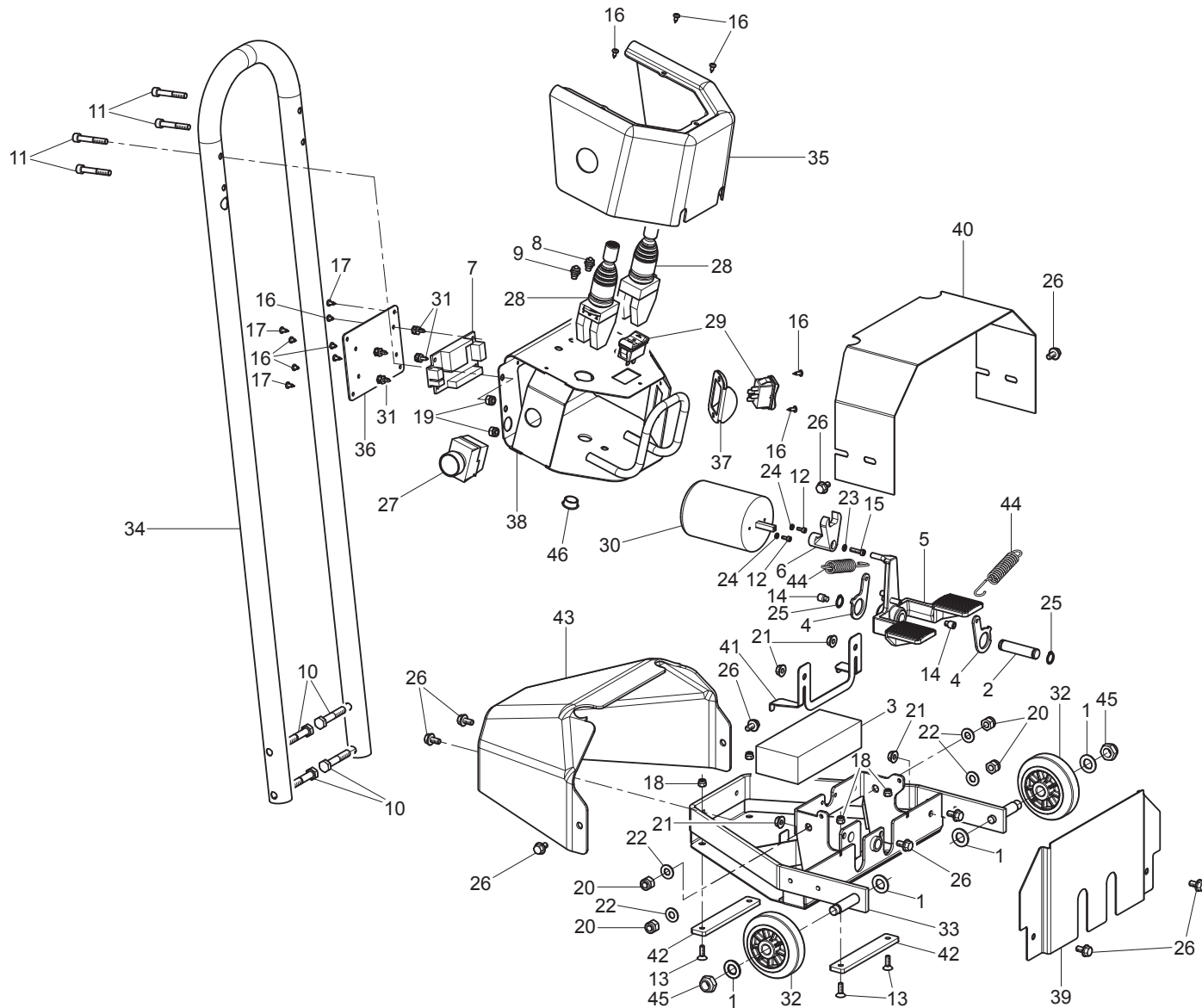
G9256.11SL	G9256.11ST	G9256.15	G9256T.15	G9256A.15	G9256D.15	G9256TD.15	G9256.15SL	G10360.15	G10360T.15	G10360A.15	G10360D.15	G10360TD.15					
								•	•	•	•	•					
 RAVAGLIOLI S.p.A.		LISTA DEI COMPONENTI - LIST OF COMPONENTS - TEILELISTE LISTE DES PIÈCES DÉTACHÉES - LISTA DE PIEZAS						CENTRALINA COMPLETA COMPLETE HYDRAULIC POWER UNIT KOMPLETTER STEUERUNG DISTRIBUTEUR COMPLÈTE CENTRALITA COMPLETA						Pag. 69 di 76			
		Tavola N°61 - Rev. 0			752292610												



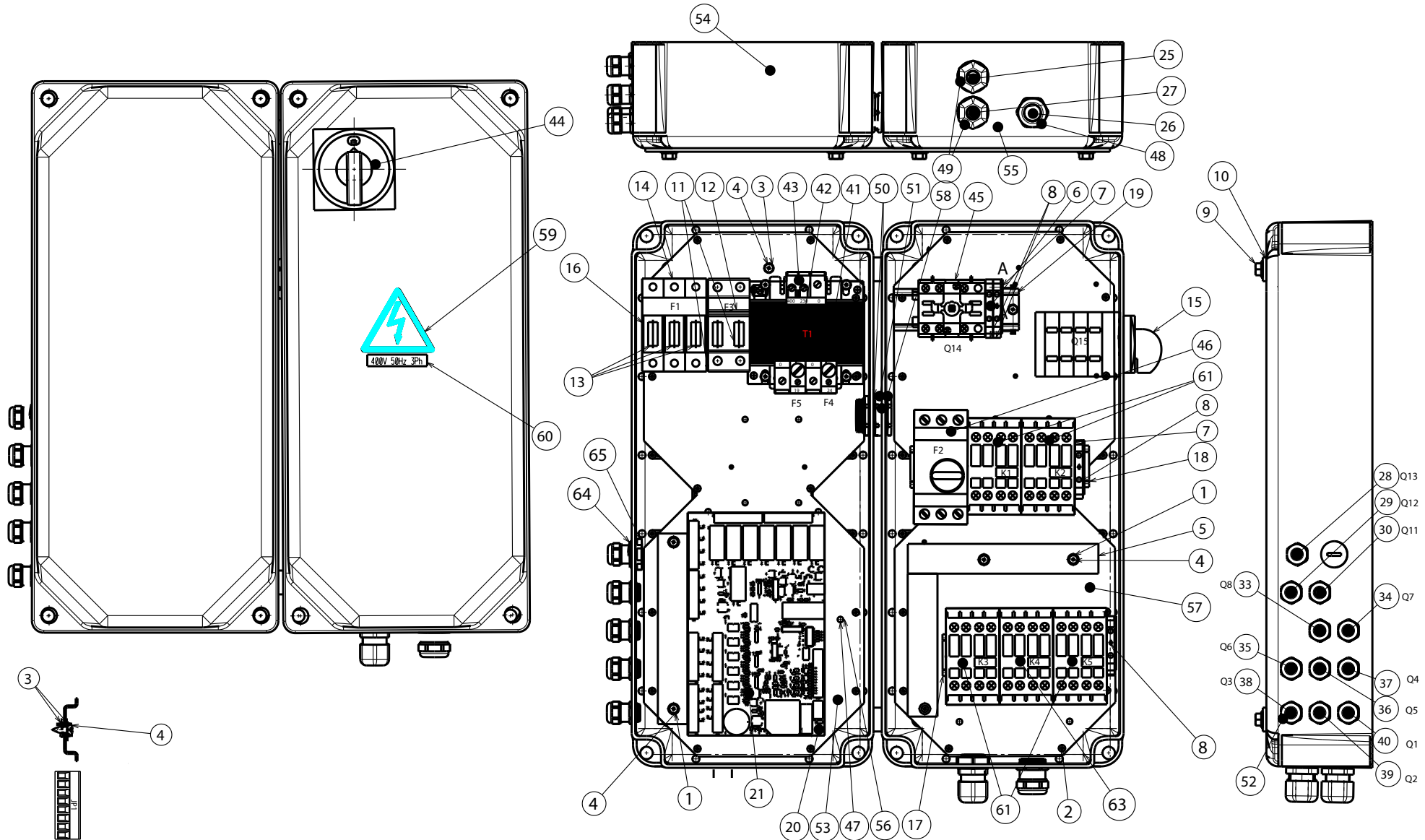
G9256.11SL	G9256.11ST	G9256.15	G9256T.15	G9256A.15	G9256D.15	G9256TD.15	G9256.15SL	G10360.15	G10360T.15	G10360A.15	G10360D.15	G10360TD.15						
VAR							VAR											
 RAVAGLIOLI S.p.A.			LISTA DEI COMPONENTI - LIST OF COMPONENTS - TEILELISTE LISTE DES PIÈCES DÉTACHÉES - LISTA DE PIEZAS										MTG CASSETTA ELETTRICA ELECTRICAL BOX MTG MTG ELEKTRISCHKISTE MTG BOÏTER ELECTRIQUE MTG CAJITA ELECTRICA				Pag. 70 di 76	
			Tavola N°62 - Rev. 0					752203180										



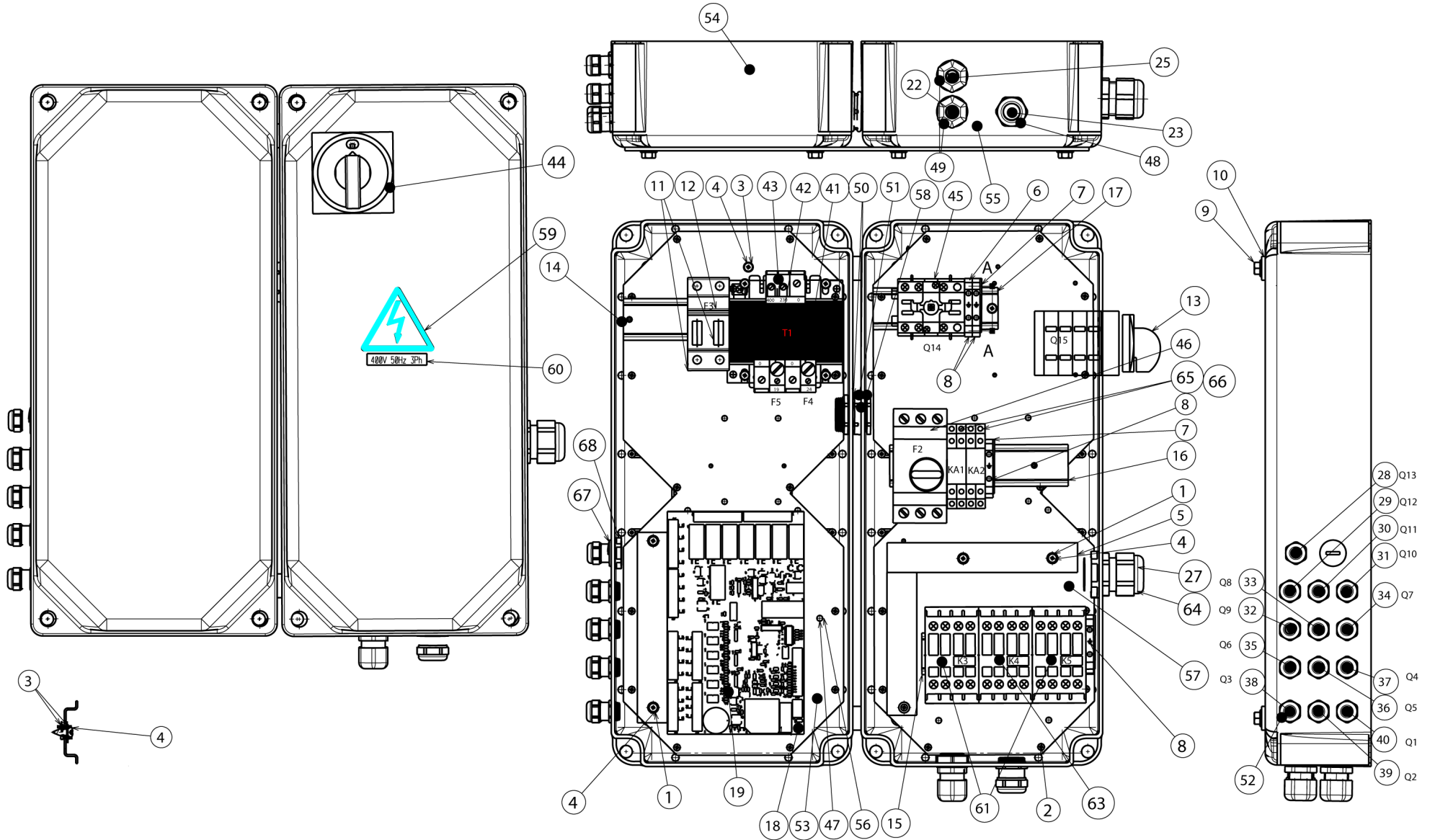
G9256.11SL	G9256.11ST	G9256.15	G9256T.15	G9256A.15	G9256D.15	G9256TD.15	G9256.15SL	G10360.15	G10360T.15	G10360A.15	G10360D.15	G10360TD.15				
VAR							VAR									
 RAVAGLIOLI S.p.A.		LISTA DEI COMPONENTI - LIST OF COMPONENTS - TEILELISTE LISTE DES PIÈCES DÉTACHÉES - LISTA DE PIEZAS						GRUPPO INVERTER INVERTER UNIT FREQUENZUMFORMERSATZ GROUPE VARIATEUR GRUPO INVERSOR					Pag. 71 di 76			
Tavola N°63 - Rev. 0							752293060									



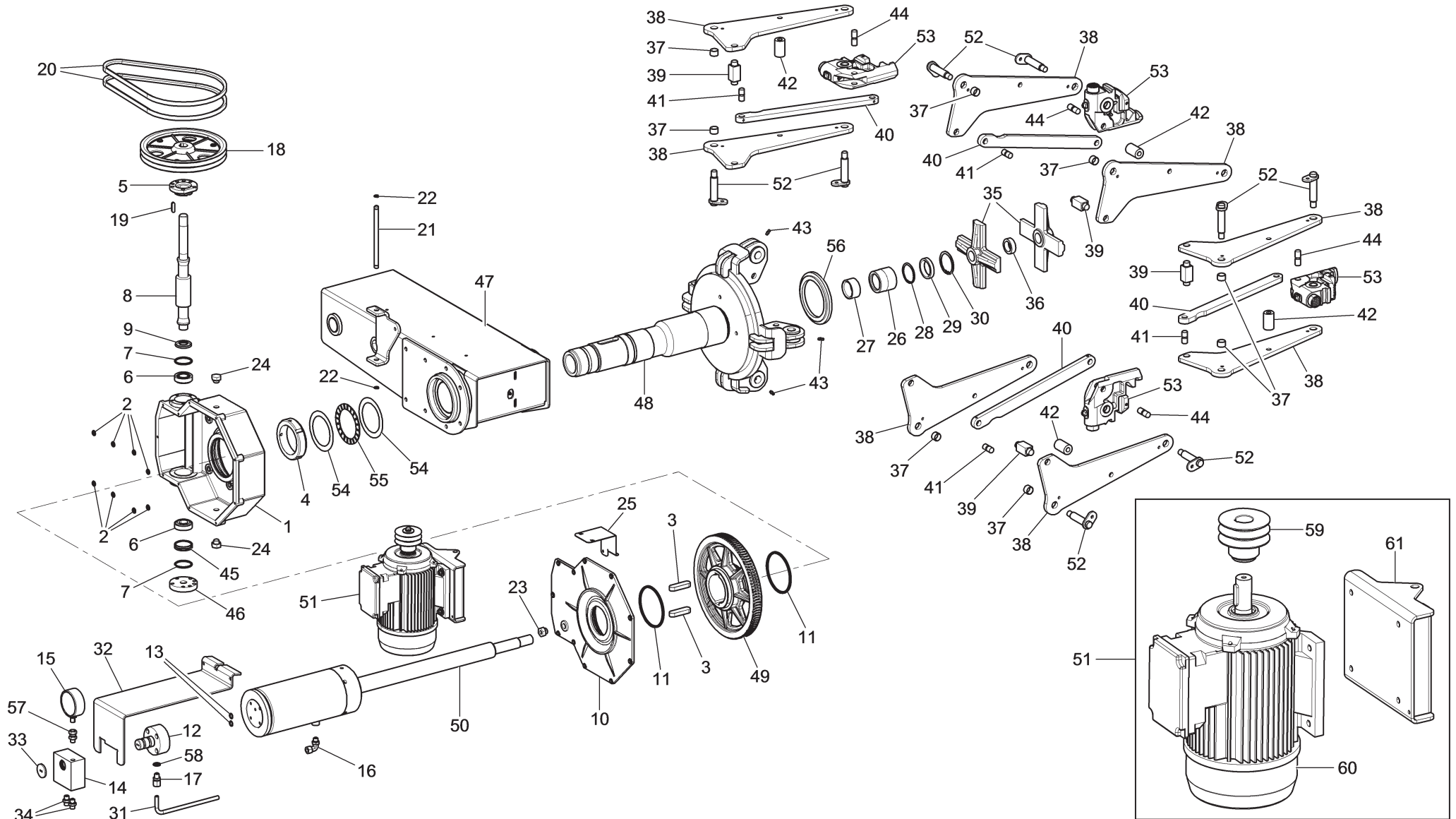
G9256.11SL	G9256.11ST	G9256.15	G9256T.15	G9256A.15	G9256D.15	G9256TD.15	G9256.15SL	G10360.15	G10360T.15	G10360A.15	G10360D.15	G10360TD.15				
		VAR	VAR		VAR	VAR		VAR	VAR		VAR	VAR				
 RAVAGLIOLI S.p.A.		LISTA DEI COMPONENTI - LIST OF COMPONENTS - TEILELISTE LISTE DES PIÈCES DÉTACHÉES - LISTA DE PIEZAS								MANIPOLATORE HANDLE MANIPULATOR MANIPULATEUR MANIPULADOR			Pag. 72 di 76			
Tavola N°64 - Rev. 0						752291171										



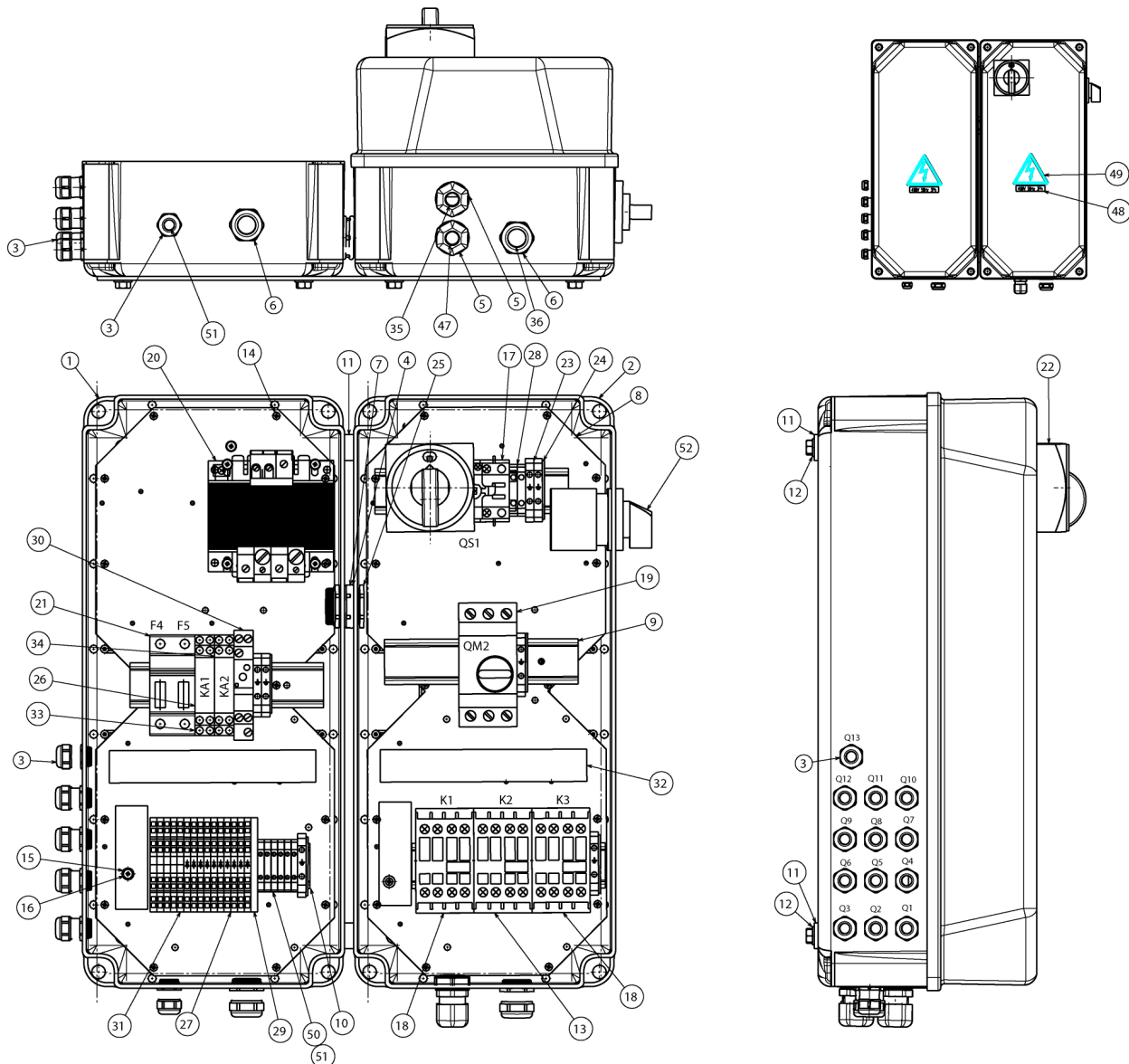
G9256.11SL	G9256.11ST	G9256.15	G9256T.15	G9256A.15	G9256D.15	G9256TD.15	G9256.15SL	G10360.15	G10360T.15	G10360A.15	G10360D.15	G10360TD.15							
		VAR	VAR					VAR	VAR										
 RAVAGLIOLI S.p.A.		LISTA DEI COMPONENTI - LIST OF COMPONENTS - TEILELISTE LISTE DES PIÈCES DÉTACHÉES - LISTA DE PIEZAS Tavola N°65 - Rev. 0								752203061				INSIEME MTG CASSETTA ELETTRICA ELECTRIC BOX MTG ASSEMBLY ENSEMBLE MTG ELEKTRISCHEKISTE ASSEMBLAGE MTG BOITIER ELECTRIQUE JUNTO MTG CAJITA ELECTRICA				Pag. 73 di 76	



G9256.11SL	G9256.11ST	G9256.15	G9256T.15	G9256A.15	G9256D.15	G9256TD.15	G9256.15SL	G10360.15	G10360T.15	G10360A.15	G10360D.15	G10360TD.15						
				VAR	VAR						VAR	VAR						
 RAVAGLIOLI S.p.A.		LISTA DEI COMPONENTI - LIST OF COMPONENTS - TEILELISTE LISTE DES PIÈCES DÉTACHÉES - LISTA DE PIEZAS								CASSETTA ELETTRICA ELECTRICAL BOX ELEKTRISCHEKISTE BOÏTER ÉLECTRIQUE CAJITA ELECTRICA				Pag. 74 di 76				
		Tavola N°66 - Rev. 0				752203092												



G9256.11SL	G9256.11ST	G9256.15	G9256T.15	G9256A.15	G9256D.15	G9256TD.15	G9256.15SL	G10360.15	G10360T.15	G10360A.15	G10360D.15	G10360TD.15				
VAR							VAR									
 RAVAGLIOLI S.p.A.		LISTA DEI COMPONENTI - LIST OF COMPONENTS - TEILELISTE LISTE DES PIÈCES DÉTACHÉES - LISTA DE PIEZAS						GRUPPO BRACCIO MANDRINO MANDREL ARM UNIT SPINDELARMSATZ GRUPE BRAS MANDRIN GRUPO BRAZO MANDRIL					Pag. 75 di 76			
Tavola N°67 - Rev. 0							752293080									



G9256.11SL	G9256.11ST	G9256.15	G9256T.15	G9256A.15	G9256D.15	G9256TD.15	G9256.15SL	G10360.15	G10360T.15	G10360A.15	G10360D.15	G10360TD.15					
											VAR	VAR					



**LISTA DEI COMPONENTI - LIST OF COMPONENTS - TEILELISTE
LISTE DES PIÈCES DÉTACHÉES - LISTA DE PIEZAS**

Tavola N°68 - Rev. 0

752203170

MTG CASSETTA ELETTRICA
ELECTRICAL BOX MTG
MTG ELEKTRISCHEKISTE
MTG BOÏTER ELECTRIQUE
MTG CAJITA ELECTRICA