

A **Nidec** Group Company

Nidec
Motors & Actuators

All for dreams™

TURN ADJUST
tilt **RAISE**
OPEN ROTATE
MOVE
close **SPIN**

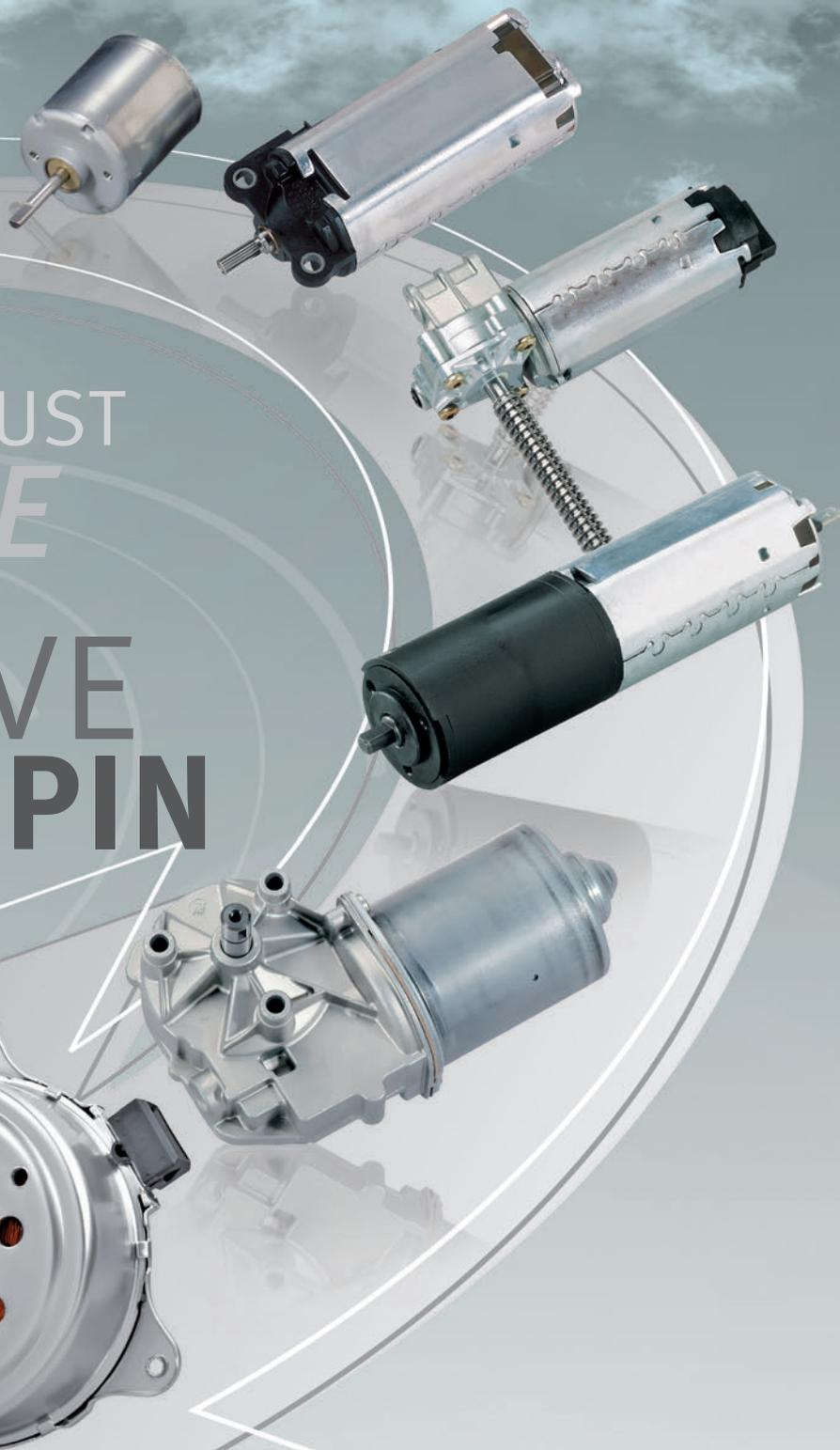

DRIVE TECHNOLOGY 2011/12

THE NIDEC MOTORS & ACTUATORS DC MOTOR RANGE

MOTORS WITHOUT GEARING

GMP



➤ Smaller diameter motors with single & double output shafts

- Nominal torque 0.05 – 0.1 Nm
- No load speed 2700 – 3250 min⁻¹

GMK
GML



➤ Higher torque single output shaft motors

- Nominal torque 0.12 – 0.4 Nm
- No load speed 2200 – 5250 min⁻¹

MOTORS WITH SPUR GEAR

GMAG
GMPI



➤ Motors that can address all your in-line drive requirements where you need higher torque, lower speed rotation

- Nominal torque 0.2 – 4 Nm
- No load speed 17 – 200 min⁻¹

MOTORS WITH WORM GEAR

GMPD
GMPG



➤ Low/medium torque with perpendicular output shafts

- Nominal torque 0.5 – 4 Nm
- No load speed 21 – 540 min⁻¹

GMPS



➤ Actuators fitted with a lead-screw to drive your linear motion needs

- Nominal axial force 1 – 2 kN
- No load speed 6 mm/s

DCK31
DCK35



➤ Cost competitive medium torque range worm drive motors

- Nominal torque 3 – 6 Nm
- No load speed 14 – 270 min⁻¹

SWMK
SW2K
SW2L



➤ Weight optimized medium torque range

- Nominal torque 0.8 – 8 Nm
- No load speed 48 – 350 min⁻¹

SWMV
SWMG



➤ Powerful medium & high torque worm gear motors

- Nominal torque 3 – 20 Nm
- No load speed 27 – 220 min⁻¹



❖❖❖ IMPORTANT EXPLANATORY INFORMATION	2
❖❖❖ DC MOTORS WITHOUT GEARING	6
<i>SERIES 0220 (GMP)</i>	7
<i>SERIES 0272 (GMK)</i>	17
<i>SERIES 0273 (GML)</i>	25
❖❖❖ DC MOTORS WITH SPUR GEAR	34
<i>SERIES 0202 (GMAG)</i>	35
<i>SERIES 0231 (GMPI)</i>	41
❖❖❖ DC MOTORS WITH WORM GEAR	48
<i>SERIES 0320 (GMPD)</i>	49
<i>SERIES 0225 (GMPG)</i>	67
<i>SERIES 0223 (SWMP)</i>	79
<i>SERIES 0321 (GMPS)</i>	91
<i>SERIES 0266 (DCK31)</i>	101
<i>SERIES 0268 (DCK35)</i>	133
<i>SERIES 0270 (SWMK)</i>	149
<i>SERIES 0277 (SW2K)</i>	163
<i>SERIES 0278 (SW2L)</i>	181
<i>SERIES 0291 (SWMV)</i>	191
<i>SERIES 0292 (SWMG)</i>	199
❖❖❖ INDEX	204

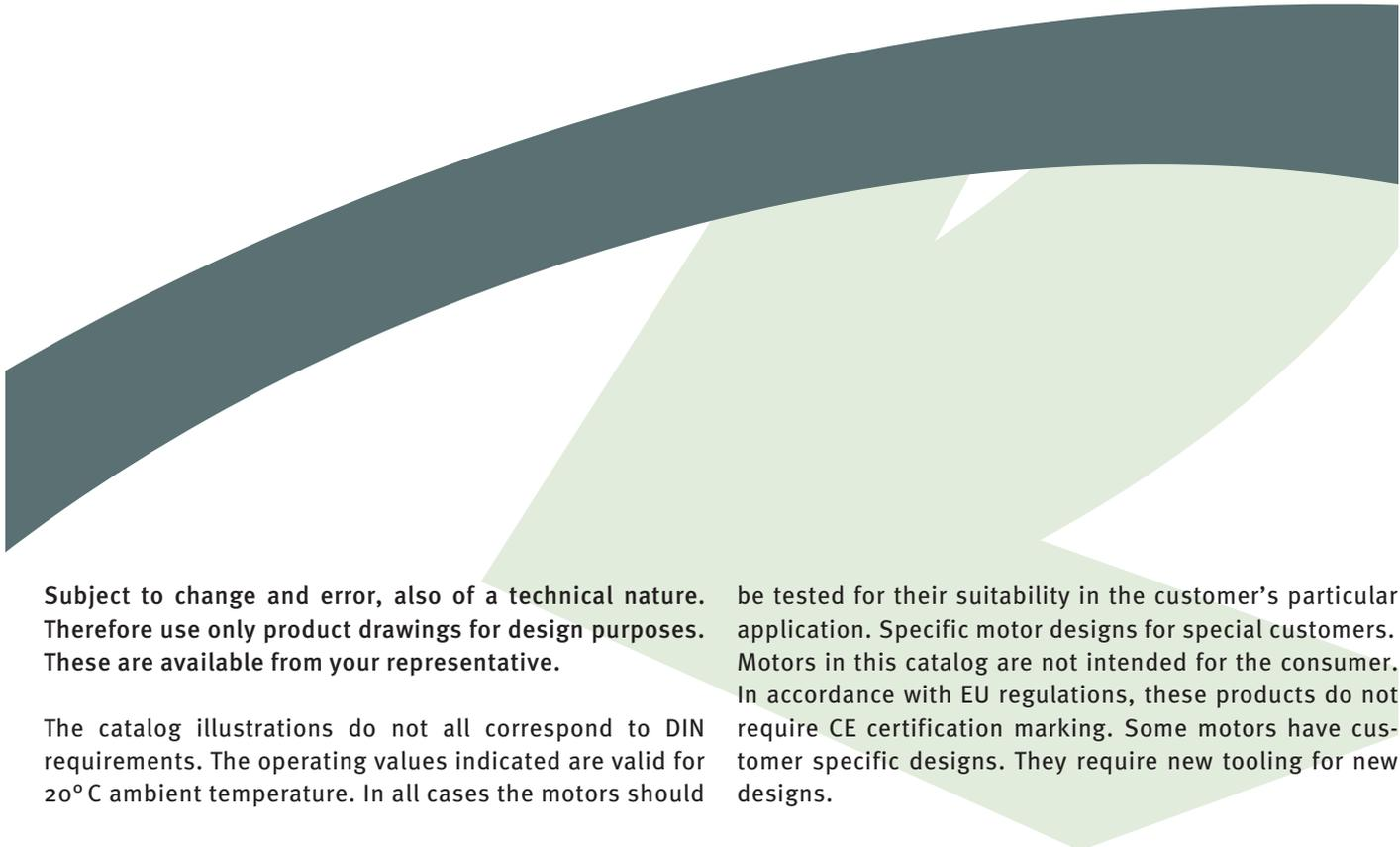

Subject to change and error, also of a technical nature. Therefore use only product drawings for design purposes. These are available from your representative.

The catalog illustrations do not all correspond to DIN requirements. The operating values indicated are valid for 20° C ambient temperature. In all cases the motors should

be tested for their suitability in the customer's particular application. Specific motor designs for special customers. Motors in this catalog are not intended for the consumer. In accordance with EU regulations, these products do not require CE certification marking. Some motors have customer specific designs. They require new tooling for new designs.

..... **TERMS, SYMBOLS AND UNITS ACCORDING TO DIN**

Symbol	Unit	Term
U_N	[V]	Rated voltage
n_o	[min ⁻¹]	No-load speed ± 10%
M_N	[Nm]	Nominal torque at the output shaft
M_A	[Nm]	Starting torque
i		Gear ratio
J_R	[kgm ²] x 10 ⁻⁶	Armature load inertia
R	[mΩ]	Armature resistance, 2/4 commutator bars
L	[mH]	Armature inductance, 2/4 commutator bars

Drawing	dimensional drawing
Shaft	dimensions of shaft ends
Wiring diagram	motor wiring diagram
Connection	dimensions and positions of motor connections
Materials	BRZ = bronze, KST = plastic, ST = steel, HGW = resinbonded fabric

	Direction of rotation when looking onto motor shaft	The curves show the speed and the current as a function of the torque. These are average values at room temperature. Divergences of ± 10 % are possible in the series.
---	---	--

	CCW		CW	Preferred direction of rotation: Worm gear motors have a preferred direction of rotation, indicated in the drawings by a larger arrow. If the motor rotates against the preferred rotation direction, power decreases by approx. 10 %.
---	-----	---	----	--



❖❖❖ **CONVERSION OF TORQUE VALUES**

(VALUES ROUNDED FOR PRACTICAL USE)

	Nm	Ncm	pcm	kpcm	kpm	oz in	in lbs	ft lbs
Nm	1	100	10.2 x 10 ³	10.2	0.102	141.6	8.85	0.738
Ncm	10 ⁻²	1	102	1.02 x 10 ⁻²	1.02 x 10 ⁻³	1.42	8.85 x 10 ⁻²	7.38 x 10 ⁻³
pcm	9.8 x 10 ⁻⁵	9.8 x 10 ⁻³	1	10 ⁻³	10 ⁻⁵	1.39 x 10 ⁻²	8.68 x 10 ⁻⁴	7.23 x 10 ⁻⁵
kpcm	9.8 x 10 ⁻²	9.8	1000	1	10 ⁻²	13.9	0.868	7.23 x 10 ⁻²
kpm	9.8	980	10 ⁵	100	1	1390	86.8	7.23
oz in	7.06 x 10 ⁻³	0.706	72	7.2 x 10 ⁻²	7.2 x 10 ⁻⁴	1	6.25 x 10 ⁻²	5.2 x 10 ⁻³
in lbs	0.113	11.3	1152	1.15	1.15 x 10 ⁻²	16	1	8.3 x 10 ⁻²
ft lbs	1.36	135.58	13,825	13.8	0.138	192	12	1

❖❖❖ **CONVERSION OF FORCES**

(VALUES ROUNDED FOR PRACTICAL USE)

	N	kp	p	oz	lbf
N	1	0.102	102	3.6	0.225
kp	9.8	1	1000	35.27	2.2
p	9.8 x 10 ⁻³	10 ⁻³	1	3.53 x 10 ⁻²	2.2 x 10 ⁻³
oz	0.278	2.83 x 10 ⁻²	28.35	1	6.25 x 10 ⁻²
lbf	4.45	0.445	453.6	16	1

❖❖❖ **CONVERSION OF POWER**

(VALUES ROUNDED FOR PRACTICAL USE)

	kW	PS	HP	kpm/s	kcal/s
kW	1	1.36	1.34	102	0.239
PS	0.735	1	0.986	75	0.176
HP	0.746	1.01	1	76	0.178
kpm/s	9.8 x 10 ⁻³	1.33 x 10 ⁻²	1.32 x 10 ⁻²	1	2.34 x 10 ⁻²
kcal/s	4.2	5.7	5.6	427	1

❖❖❖ **CONVERSION OF TEMPERATURES**

t_c [°C] Celsius	t_f [°F] Fahrenheit	T_k [K] Kelvin	T_r [°R] Rankine
$t_c = \frac{5}{9} (t_f - 32)$	$t_f = \frac{9}{5} t_c + 32$	$T_k = t_c + 273$	$T_r = \frac{9}{5} (t_c + 273)$
$t_c = \frac{5}{9} T_r - 273$		$T_k = \frac{5}{9} T_r$	
		$T_k = \frac{5}{9} (t_f + 255)$	



❖❖❖ **TOLERANCE ZONES TO ISO/R 286**

(DIN 7150, 7151, 7152, 7154, 7155)

1,1 H 13:	+0.140 / 0 mm	5,1 H 11:	+0.075 / 0 mm	9 k 5:	+0.007 / +0.001mm
1,6 H 13:	+0.140 / 0 mm	5,1 H 12:	+0.120 / 0 mm	9,4 h 11:	0 / -0.090 mm
2,5 H 12:	+0.100 / 0 mm	5,5 h 11:	0 / -0.075 mm	9,5 js 11:	+0.045 / -0.045 mm
2,7 H 12:	+0.100 / 0 mm	5,5 H 13:	+0.180 / 0 mm	9,6 h 11:	0 / -0.090 mm
3 H 9:	+0.025 / 0 mm	5,8 g 6:	-0.004 / -0.012 mm	9,75 g 5:	-0.006 / -0.014 mm
3 H 12:	+0.100 / 0 mm	5,9 c 9:	-0.070 / -0.100 mm	10 f 6:	-0.013 / -0.022 mm
3 N 9:	-0.004 / -0.029 mm	5,9 h 10:	0 / -0.048 mm	10 f 7:	-0.013 / -0.028 mm
3 P 8:	-0.006 / -0.020 mm	6 f 9:	-0.010 / -0.040 mm	10 f 8:	-0.013 / -0.035 mm
3 P 9:	-0.006 / -0.031 mm	6 fg 9:	-0.006 / -0.014 mm	10 g 5:	-0.005 / -0.011 mm
3 P 10:	-0.006 / -0.046 mm	6 h 6:	0 / -0.008 mm	10 g 6:	-0.005 / -0.014 mm
3,1 JS 10:	+0.024 / -0.024 mm	6 h 8:	0 / -0.018 mm	10 h 5:	0 / -0.006 mm
3,5 H 12:	+0.120 / 0 mm	6 h 9:	0 / -0.030 mm	10 h 7:	0 / -0.015 mm
3,6 H 11:	+0.075 / 0 mm	6 m 6:	+0.012 / +0.004 mm	10 h 9:	0 / -0.036 mm
4 C 10:	+0.118 / -0.070 mm	6,3 H 12:	+0.150 / 0 mm	11 d 10:	-0.050 / -0.120 mm
4 h 6:	0 / -0.008 mm	6,5 H 8:	+0.022 / 0 mm	11,2 e 10:	-0.032 / -0.102 mm
4 h 8:	0 / -0.018 mm	6,8 h 8:	0 / -0.022 mm	11,5 h 11:	0 / -0.110 mm
4 h 9:	0 / -0.030 mm	7 h 8:	0 / -0.022 mm	12 f 7:	-0.016 / -0.034 mm
4 h 10:	0 / -0.048 mm	7,6 h 11:	0 / -0.090 mm	12 g 5:	-0.006 / -0.014 mm
4 h 11:	0 / -0.075 mm	8 f 6:	-0.013 / -0.022 mm	12 h 6:	0 / -0.011 mm
4 H 12:	+0.120 / 0 mm	8 g 6:	-0.005 / -0.014 mm	12 h 7:	0 / -0.018 mm
4 P 9:	-0.012 / -0.042 mm	8 g 7:	-0.005 / -0.020 mm	12 h 9:	0 / -0.036 mm
4,1 h 10:	0 / -0.048 mm	8 g 9:	-0.005 / -0.041 mm	12 h 11:	0 / -0.110 mm
4,1 H 11:	+0.075 / 0 mm	8 h 9:	0 / -0.036 mm	13,4 h 11:	0 / -0.110 mm
4,2 H 7:	+0.012 / 0 mm	8 H 9:	+0.036 / 0 mm	14 f 6:	-0.016 / -0.027 mm
4,2 H 12:	+0.120 / 0 mm	8 h 10:	0 / -0.058 mm	14 f 7:	-0.016 / -0.034 mm
4,5 H 13:	+0.180 / 0 mm	8 h 11:	0 / -0.090 mm	14 H 7:	+0.018 / 0 mm
5 c 11:	-0.070 / -0.145 mm	8 k 5:	+0.007 / +0.001 mm	15 f 7:	-0.016 / -0.034 mm
5 h 6:	0 / -0.008 mm	8,5 h 9:	0 / -0.036 mm	15,2 h 11:	0 / -0.110 mm
5 h 9:	0 / -0.030 mm	8,7 h 11:	0 / -0.090 mm	16 f 6:	-0.016 / -0.027 mm
5 h 10:	0 / -0.048 mm	9 D 9:	+0.076 / +0.040 mm	18 H 8:	+0.027 / 0 mm
5 h 12:	0 / -0.120 mm	9 h 6:	0 / -0.009 mm	20 h 9:	0 / -0.052 mm
5 P 9:	-0.012 / -0.042 mm	9 h 11:	0 / -0.090 mm	26 g 6:	-0.007 / -0.020 mm

❖❖❖ **TOLERANCE ZONES**

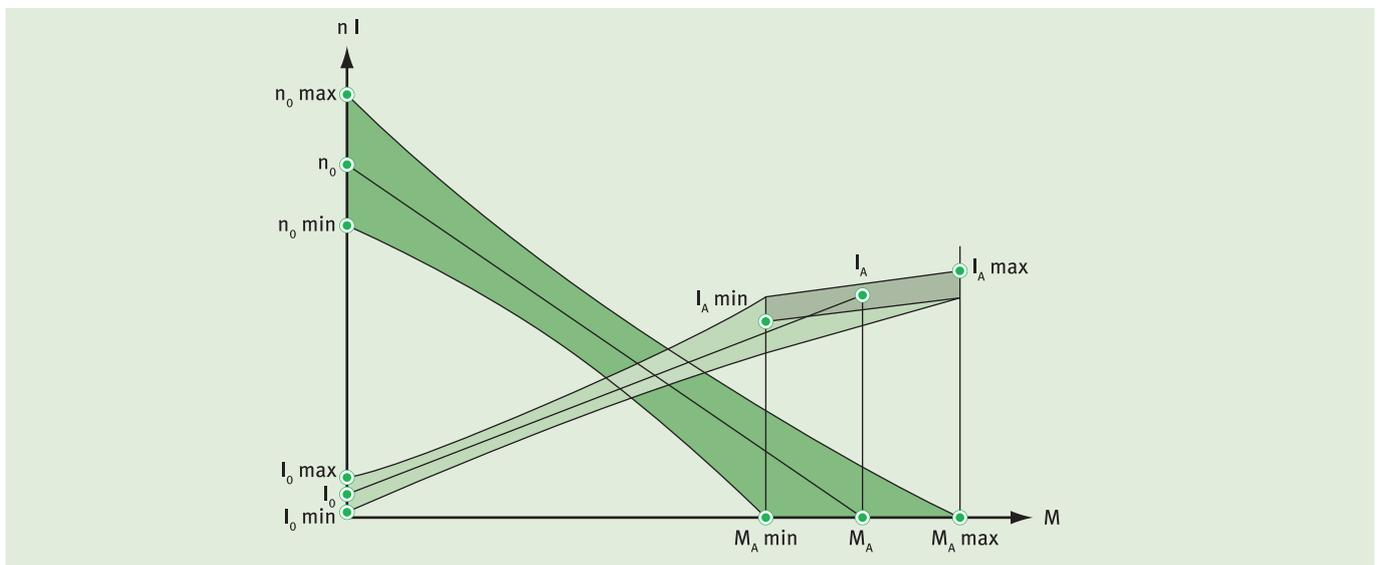



CHARACTERISTIC CURVES

CR	Continuous running	n_0	No-load speed in min^{-1}
SO	Short operation	n_N	Rated speed in min^{-1}
VSO	Very short operation	n_{SO}	Speed for short operation in min^{-1}
P	Power in W	n_{VSO}	Speed for very short operation in min^{-1}
P_{2N}	Nominal output power in W	I	Current in A
P_{2max}	Maximum output power in W	I_0	No-load current in A
P_{2SO}	Output power for short operation in W	I_A	Starting current in A
P_{2VSO}	Output power for very short operation in W	I_N	Rated current in A
M	Torque in Nm	I_{SO}	Current for short operation in A
M_A	Starting torque in Nm	I_{VSO}	Current for very short operation in A
M_N	Nominal output torque in Nm	η	Efficiency in %
M_{SO}	Output torque for short operation in Nm	η_N	Rated efficiency in %
M_{VSO}	Output torque for very short operation in Nm	η_{SO}	Efficiency for short operation in %
n	Rotational speed in min^{-1}	η_{VSO}	Efficiency for very short operation in %

RANGE OF OPERATION

- Continuous running
- Short operation
- Very short operation

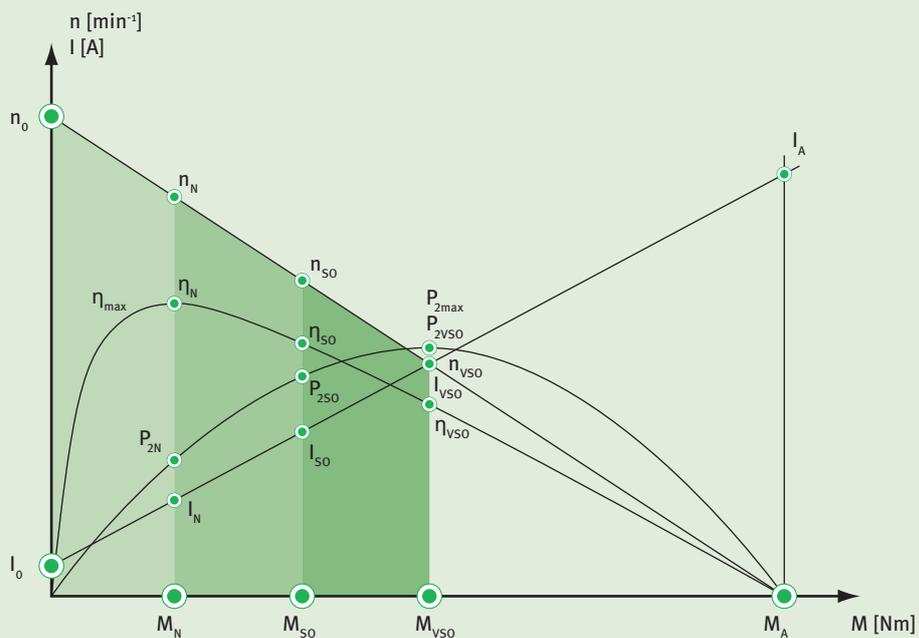



NIDEC MOTORS & ACTUATORS ❖❖❖ MOTOR SERIES

0220 (GMP)

❖❖❖ DC MOTORS WITHOUT GEARING

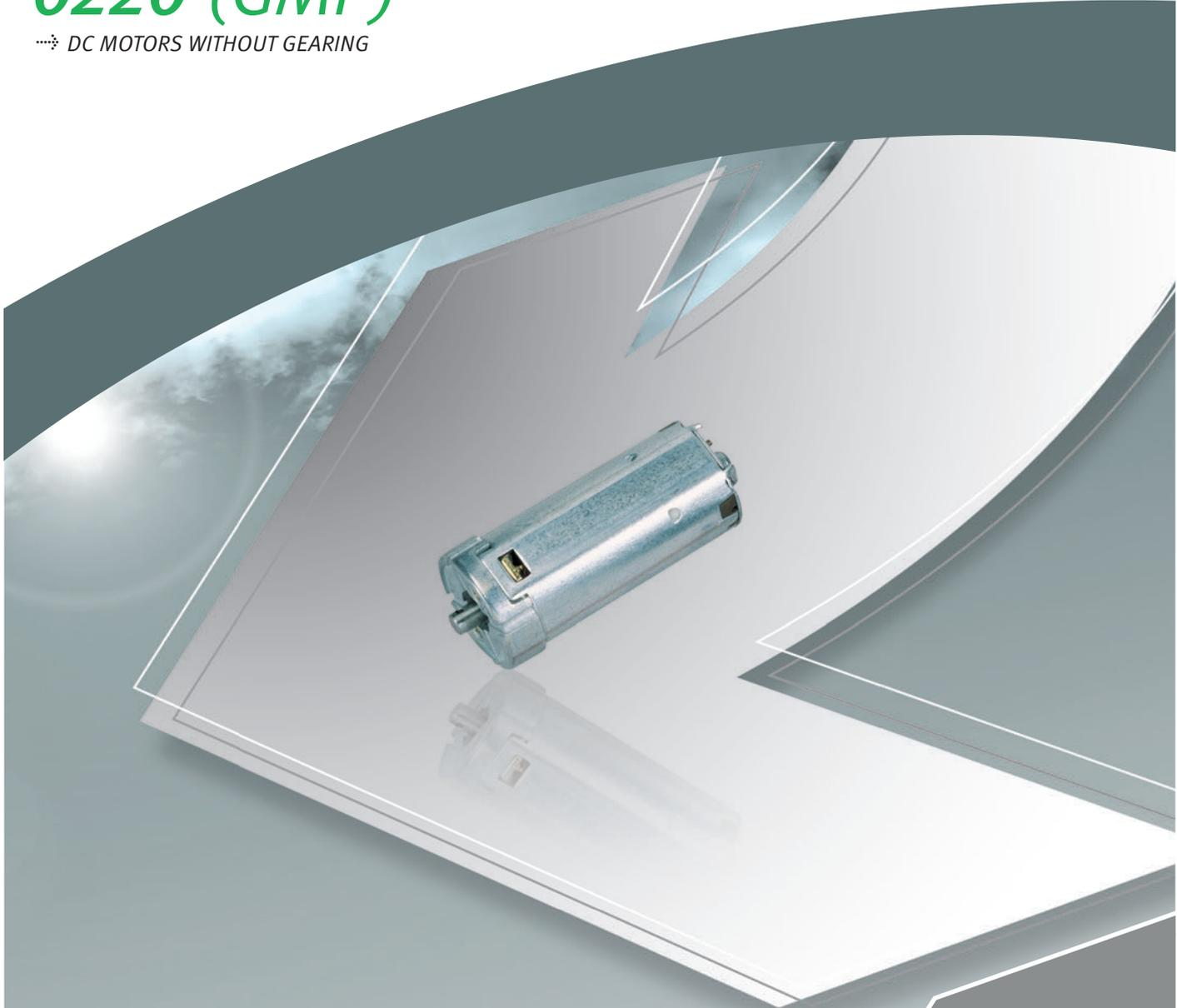

❖❖❖ TECHNICAL DESCRIPTION

Motorhousing:	sheet metal, rolled & corrosion protected
Excitation field:	permanent magnet
Type of gear mesh:	-
Gear housing:	-
Gear wheel material:	-
Lubrication:	-
Mechanical interface:	steel shaft
Electric interface:	connector or leads with connector
Sensor:	optional
Thermal protection:	optional
EMC suppression:	optional

❖❖❖ INDUSTRIAL APPLICATION

Linear drives, machine construction

❖❖❖ AUTOMOTIVE APPLICATION

Seat track drive

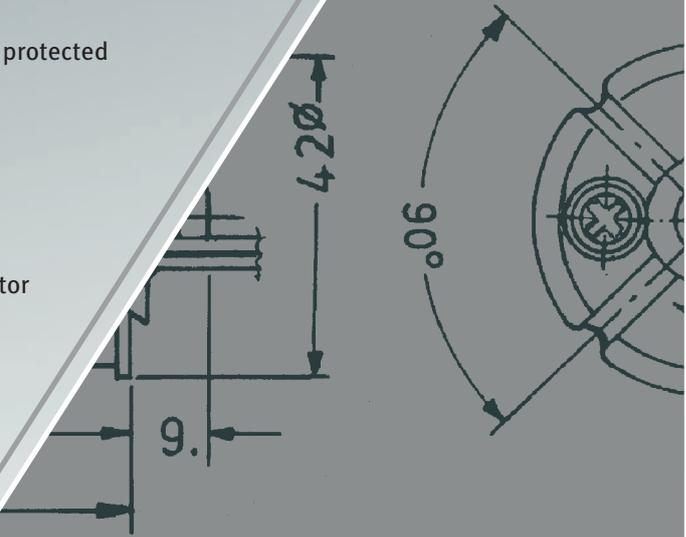

Design Data	
Commutation	Brushed
Direction of rotation	Bi-directional
Bearing type	A:Ball - B:Sleeve

Performance data		
Rated voltage [V]	U_N	12
Nominal torque [Nm]	M_N	0.08
No-load speed [min^{-1}]	n_0	2,700.0
Nominal power [W]	P_N	16.2
Nominal current [A]	I_N	2.0
Nominal force [kN]	F_N	0.00
Duty cycle		s3

Sensor data	
Pulses	0
Output channels	0

Other data	
Gear ratio	
Gear wheel material	
Suppression components	7,5 μ H
Enclosure class	IP 30
Weight [kg]	0.550

Remarks:

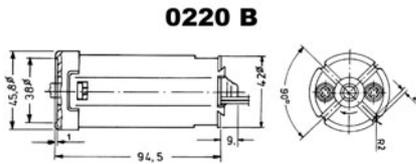

Motor picture

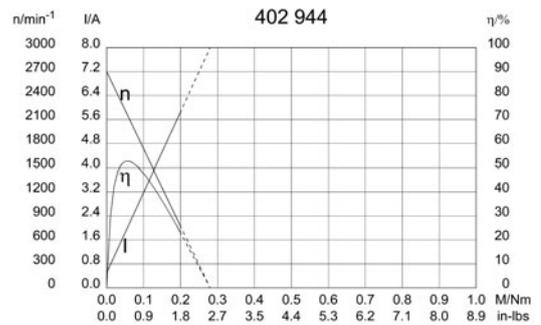

Output shaft drawing (W), Wiring diagrams (S) and Connector layout (K)

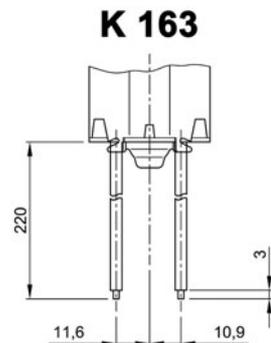
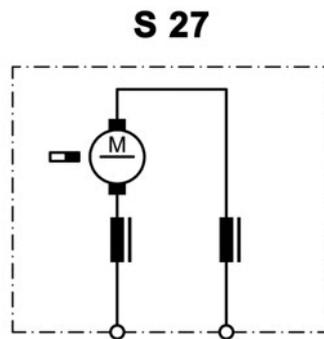
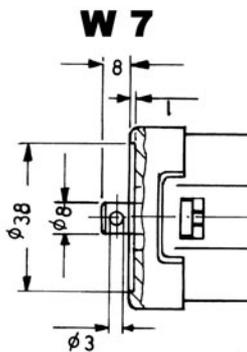

Design Data	
Commutation	Brushed
Direction of rotation	Bi-directional
Bearing type	A:Ball - B:Ball

Performance data		
Rated voltage [V]	U_N	24
Nominal torque [Nm]	M_N	0.08
No-load speed [min^{-1}]	n_0	2,800.0
Nominal power [W]	P_N	17.6
Nominal current [A]	I_N	1.0
Nominal force [kN]	F_N	0.00
Duty cycle	s3	

Sensor data	
Pulses	0
Output channels	0

Other data	
Gear ratio	
Gear wheel material	
Suppression components	7.5 μ H, 47nF
Enclosure class	IP 30
Weight [kg]	0.550

Remarks:

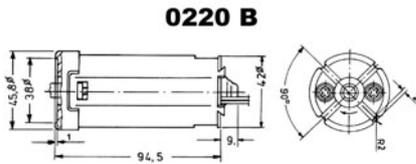

Motor picture



Characteristic curves

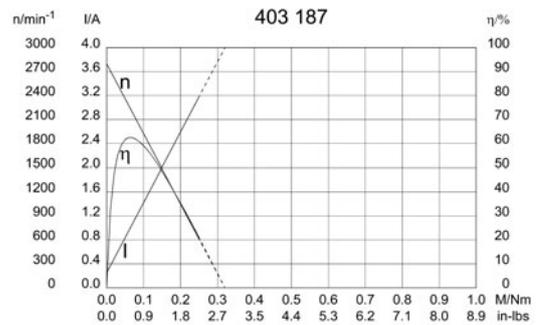

Output shaft drawing (W), Wiring diagrams (S) and Connector layout (K)

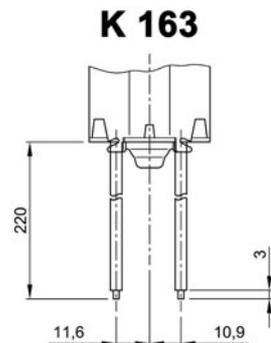
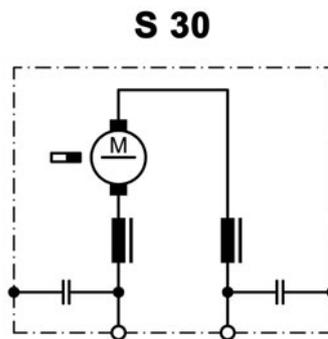
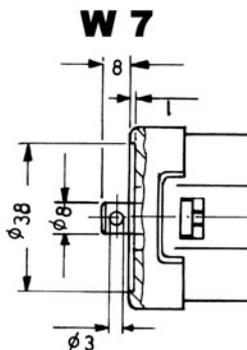

Design Data	
Commutation	Brushed
Direction of rotation	Bi-directional
Bearing type	A:Sleeve - B:Sleeve

0220 F

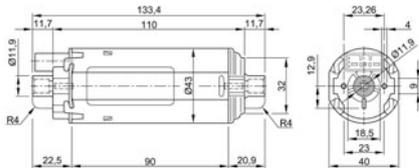

Performance data		
Rated voltage [V]	U_N	12
Nominal torque [Nm]	M_N	0.10
No-load speed [min^{-1}]	n_0	2,700.0
Nominal power [W]	P_N	21.2
Nominal current [A]	I_N	3.0
Nominal force [kN]	F_N	0.00
Duty cycle		s3

Sensor data	
Pulses	0
Output channels	0

Other data	
Gear ratio	
Gear wheel material	
Suppression components	2,5µH, 47nF ()
Enclosure class	IP 40
Weight [kg]	0.560

Remarks:

Motor picture



Characteristic curves

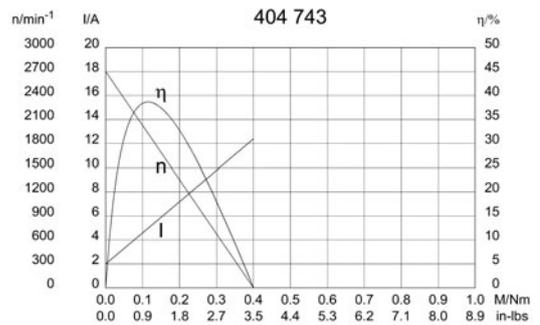

Output shaft drawing (W), Wiring diagrams (S) and Connector layout (K)

W 266

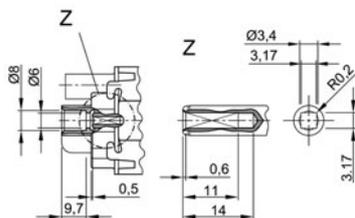

W 267

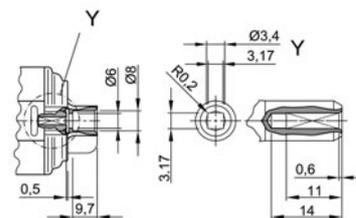

S 93

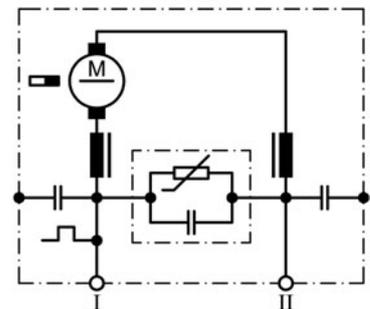

I Terminal 1
 II Terminal 5

Design Data	
Commutation	Brushed
Direction of rotation	Bi-directional
Bearing type	A:Sleeve - B:Sleeve

Performance data		
Rated voltage [V]	U_N	12
Nominal torque [Nm]	M_N	0.10
No-load speed [min^{-1}]	n_0	2,700.0
Nominal power [W]	P_N	21.2
Nominal current [A]	I_N	4.5
Nominal force [kN]	F_N	0.00
Duty cycle		s3

0220 F

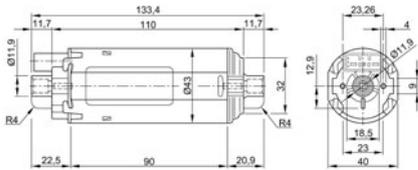

Sensor data	
Pulses	1
Output channels	1

Other data	
Gear ratio	
Gear wheel material	
Suppression components	2,5 μ H, 47nF
Enclosure class	IP 40
Weight [kg]	0.560

Remarks:

Motor picture



Characteristic curves

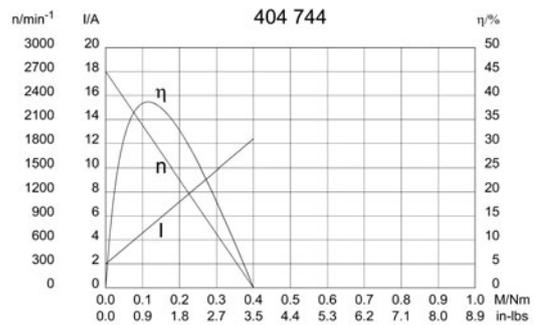

Output shaft drawing (W), Wiring diagrams (S) and Connector layout (K)

W 266

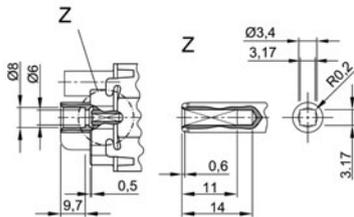

W 267

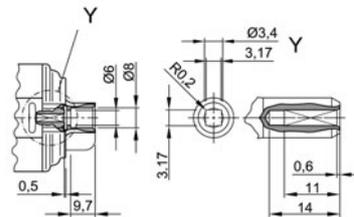

S 86

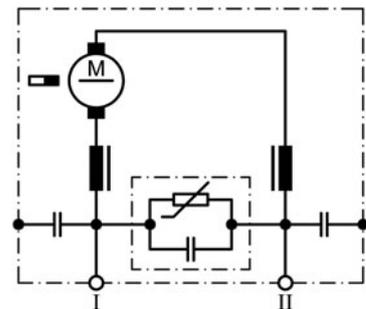

I Terminal 1
 II Terminal 5



NIDEC MOTORS & ACTUATORS ❖❖❖ MOTOR SERIES

0272 (GMK)

❖❖❖ DC MOTORS WITHOUT GEARING

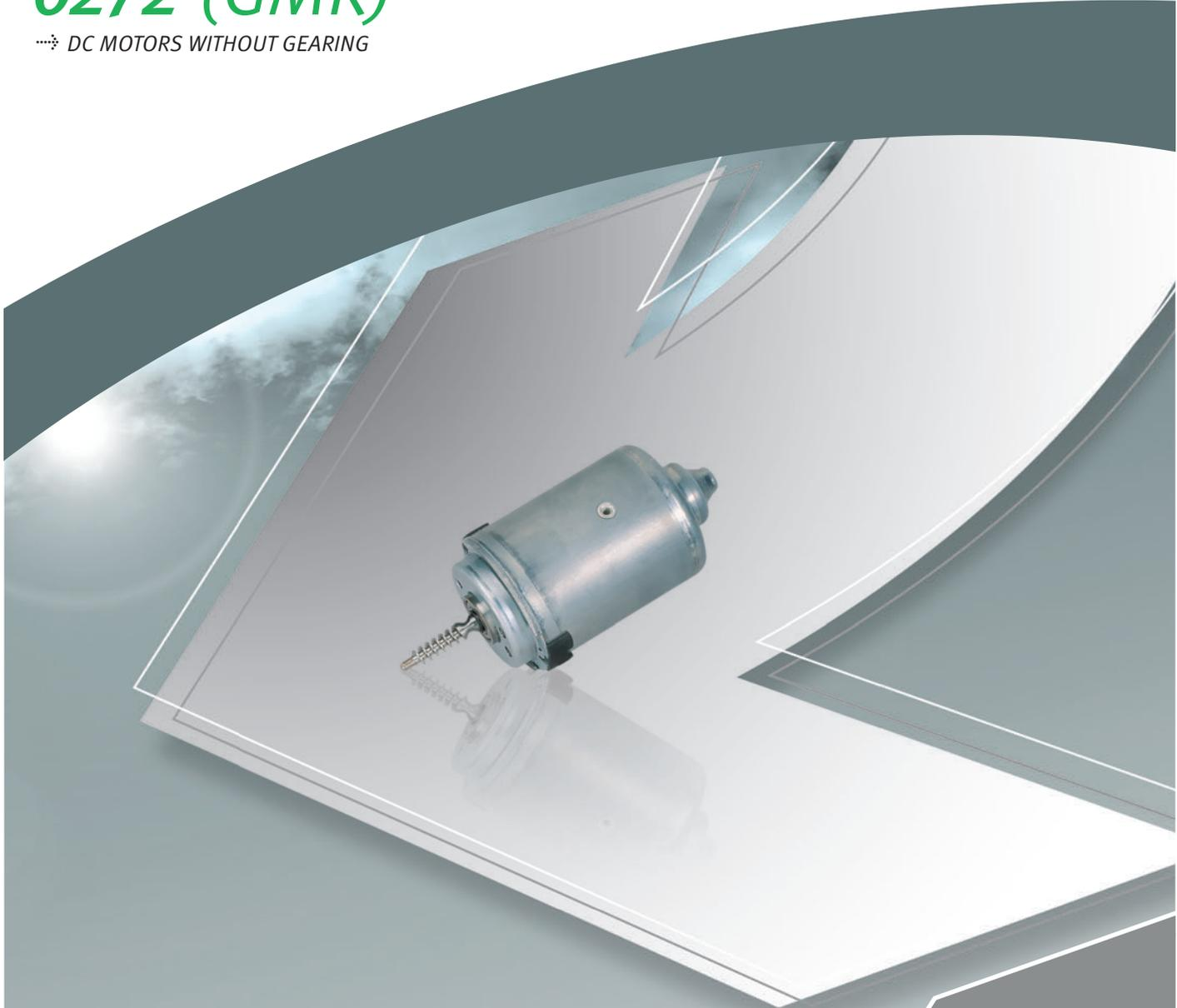

❖❖❖ TECHNICAL DESCRIPTION

Motorhousing:	deep drawn & corrosion protected
Excitation field:	permanent magnet
Type of gear mesh:	-
Gear housing:	-
Gear wheel material:	-
Lubrication:	grease
Mechanical interface:	steel shaft
Electric interface:	leads with connector
Sensor:	optional
Thermal protection:	optional
EMC suppression:	optional

❖❖❖ INDUSTRIAL APPLICATION

Linear drives

❖❖❖ AUTOMOTIVE APPLICATION

Electric torque management,
Automated manual transmission

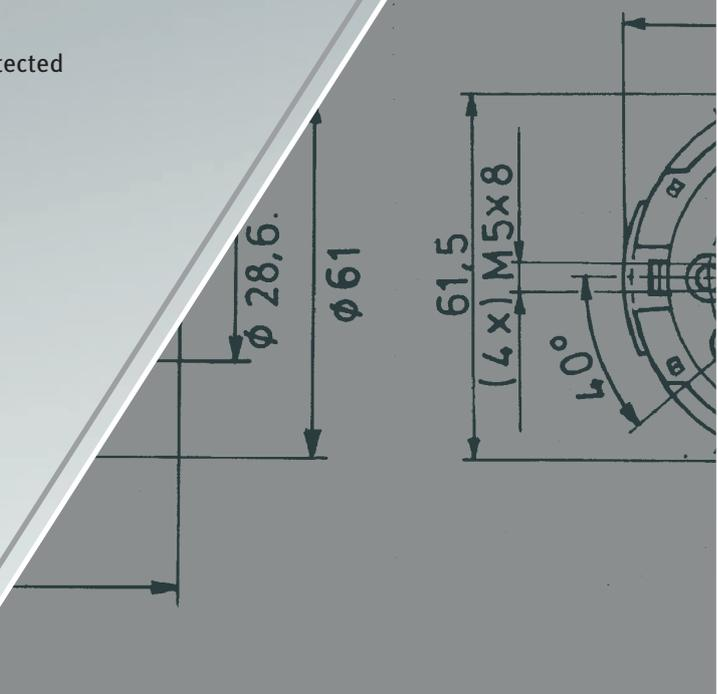

Design Data	
Commutation	Brushed
Direction of rotation	Bi-directional
Bearing type	

Performance data		
Rated voltage [V]	U_N	24
Nominal torque [Nm]	M_N	0.19
No-load speed [min^{-1}]	n_0	3,100.0
Nominal power [W]	P_N	52.7
Nominal current [A]	I_N	5.0
Nominal force [kN]	F_N	0.00
Duty cycle		s1

Sensor data	
Pulses	0
Output channels	0

Other data	
Gear ratio	
Gear wheel material	
Suppression components	5 μ H
Enclosure class	IP 30
Weight [kg]	0.900

Remarks: 1 start worm

Characteristic curves

Motor picture

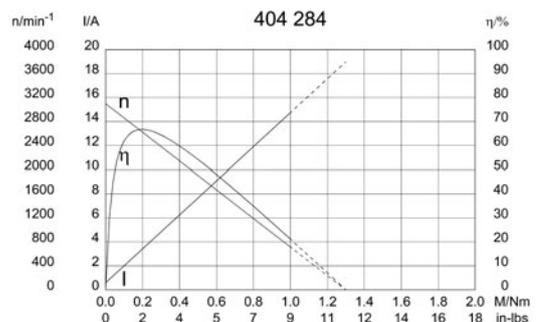
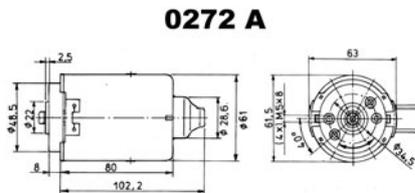

Output shaft drawing (W), Wiring diagrams (S) and Connector layout (K)

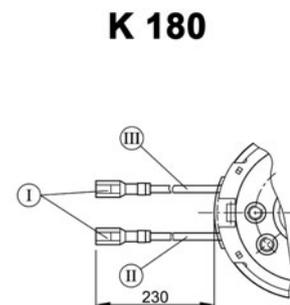
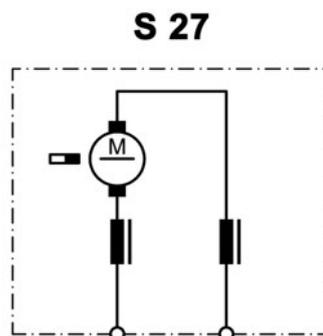
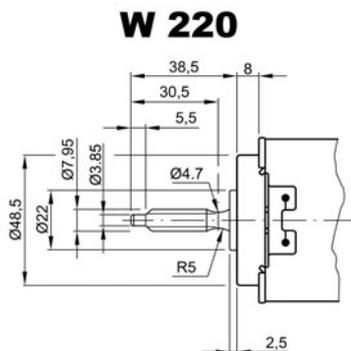

no of starts 1, lead angle 9°, pressure angle 10°, module 1, pitch 3,14159 mm (0,124")

I Blade terminal receptacles 2,8 x 0,8 DIN 46 247
 II green
 III red

Design Data	
Commutation	Brushed
Direction of rotation	Bi-directional
Bearing type	A:Ball - B:Sleeve

Performance data		
Rated voltage [V]	U_N	24
Nominal torque [Nm]	M_N	0.12
No-load speed [min^{-1}]	n_0	3,800.0
Nominal power [W]	P_N	43.9
Nominal current [A]	I_N	3.0
Nominal force [kN]	F_N	0.00
Duty cycle		s1

Sensor data	
Pulses	0
Output channels	0

Other data	
Gear ratio	
Gear wheel material	
Suppression components	5 μ H, 1nF
Enclosure class	IP 30
Weight [kg]	0.900

Remarks: 4 start worm

Characteristic curves

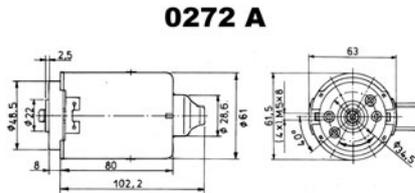

Motor picture

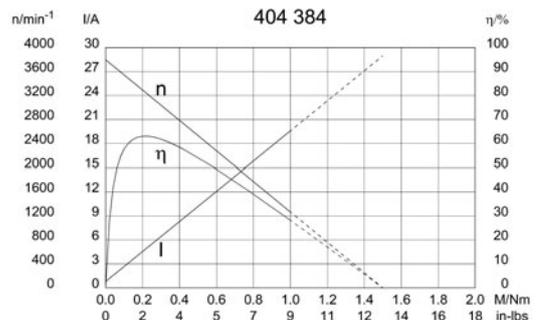

Output shaft drawing (W), Wiring diagrams (S) and Connector layout (K)

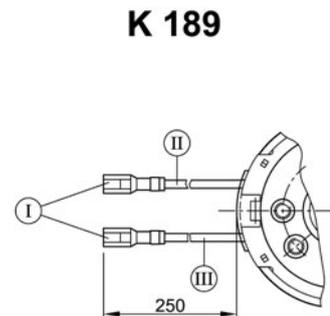
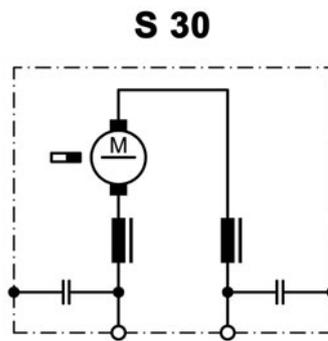
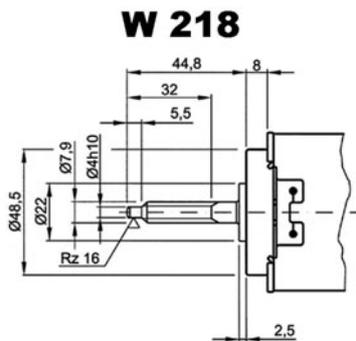

no of starts 4 ,lead angle 30°31'35", pressure angle: 15°, pitch 11.6707 mm (0,459"), module 0,8

I Receptacle for tabs 2,8 x 0,8 DIN 46 247
 II red
 III black

Design Data	
Commutation	Brushed
Direction of rotation	Bi-directional
Bearing type	A:Ball - B:Sleeve

Performance data		
Rated voltage [V]	U_N	12
Nominal torque [Nm]	M_N	0.35
No-load speed [min^{-1}]	n_0	3,000.0
Nominal power [W]	P_N	79.2
Nominal current [A]	I_N	9.0
Nominal force [kN]	F_N	0.00
Duty cycle		s3

Sensor data	
Pulses	0
Output channels	0

Other data	
Gear ratio	
Gear wheel material	
Suppression components	5 μ H, 10nF
Enclosure class	IP 30
Weight [kg]	0.900

Remarks:

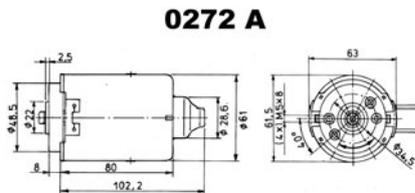

Motor picture



Characteristic curves

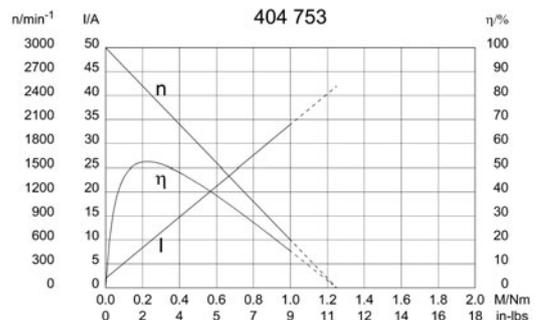

Output shaft drawing (W), Wiring diagrams (S) and Connector layout (K)

W 280

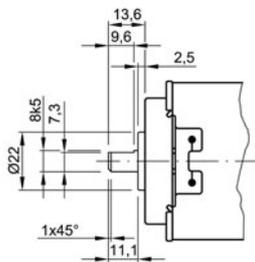

S 30

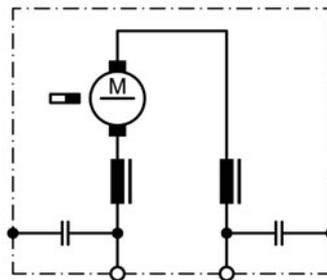

K 190

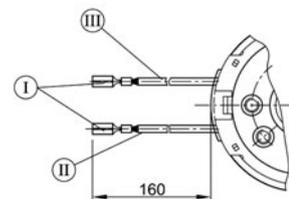

- I Receptacles for tabs 2,8 x 0,8 DIN 46 247
- II black
- III red

Design Data	
Commutation	Brushed
Direction of rotation	Bi-directional
Bearing type	A:Ball - B:Sleeve

Performance data		
Rated voltage [V]	U_N	24
Nominal torque [Nm]	M_N	0.30
No-load speed [min^{-1}]	n_0	2,200.0
Nominal power [W]	P_N	53.2
Nominal current [A]	I_N	3.0
Nominal force [kN]	F_N	0.00
Duty cycle		s1

Sensor data	
Pulses	0
Output channels	0

Other data	
Gear ratio	
Gear wheel material	
Suppression components	5 μ H, 10nF
Enclosure class	IP 30
Weight [kg]	0.890

Remarks:

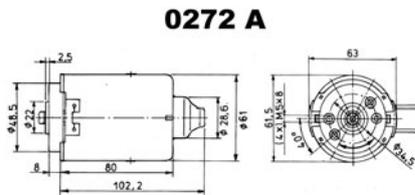

Motor picture



Characteristic curves

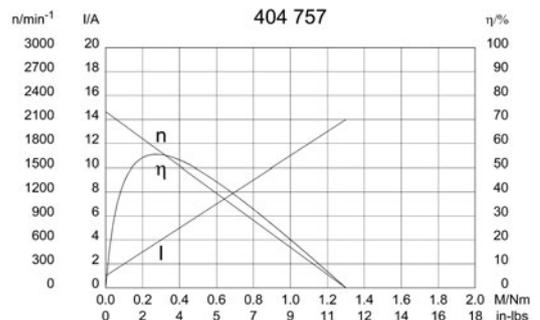

Output shaft drawing (W), Wiring diagrams (S) and Connector layout (K)

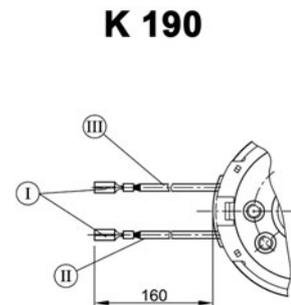
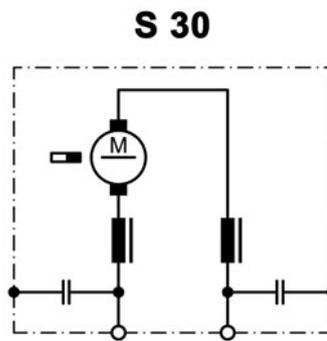
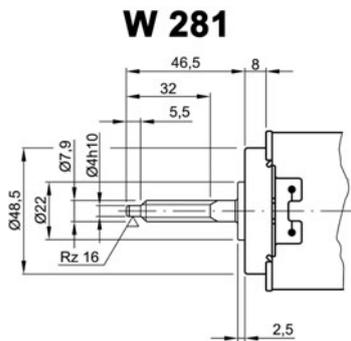

no of starts 2 , lead angle 19°48'54" , pressure angle 15° , pitch 3,141 mm (0,124") , module 1

I Receptacles for tabs 2,8 x 0,8 DIN 46 247
 II black
 III red

Design Data	
Commutation	Brushed
Direction of rotation	Bi-directional
Bearing type	A:Ball - B:Sleeve

Performance data		
Rated voltage [V]	U_N	24
Nominal torque [Nm]	M_N	0.15
No-load speed [min^{-1}]	n_0	2,200.0
Nominal power [W]	P_N	30.9
Nominal current [A]	I_N	2.5
Nominal force [kN]	F_N	0.00
Duty cycle	s1	

Sensor data	
Pulses	0
Output channels	0

Other data	
Gear ratio	
Gear wheel material	
Suppression components	5 μ H
Enclosure class	IP 30
Weight [kg]	0.900

Remarks: 3 start worm

Characteristic curves

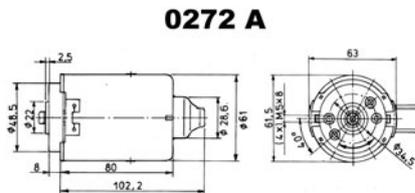

Motor picture

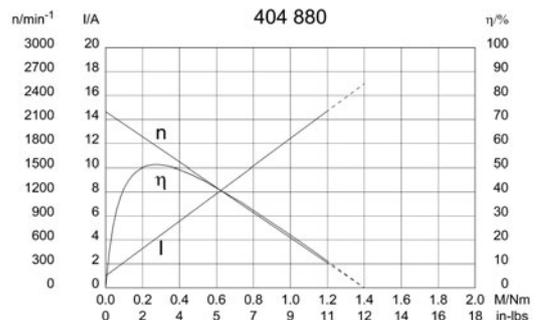

Output shaft drawing (W), Wiring diagrams (S) and Connector layout (K)

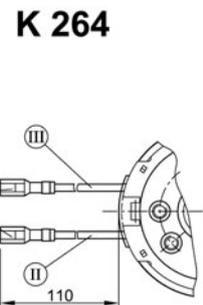
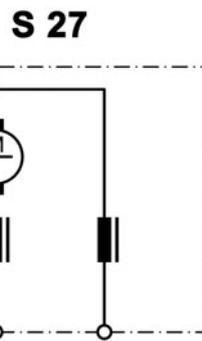
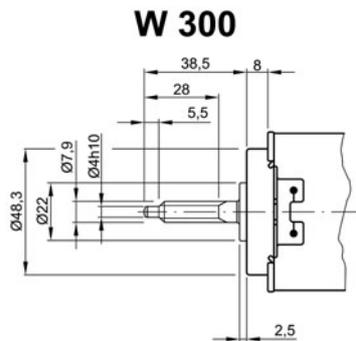

no of starts 3, lead angle 30°33'44", pressure angle 15°, module 1, pitch 3,141 mm (0,124")

I Receptacle for tabs 2,8 x 0,8 DIN 46 247
 II green
 III red



0273 (GML)

❖❖❖ DC MOTORS WITHOUT GEARING

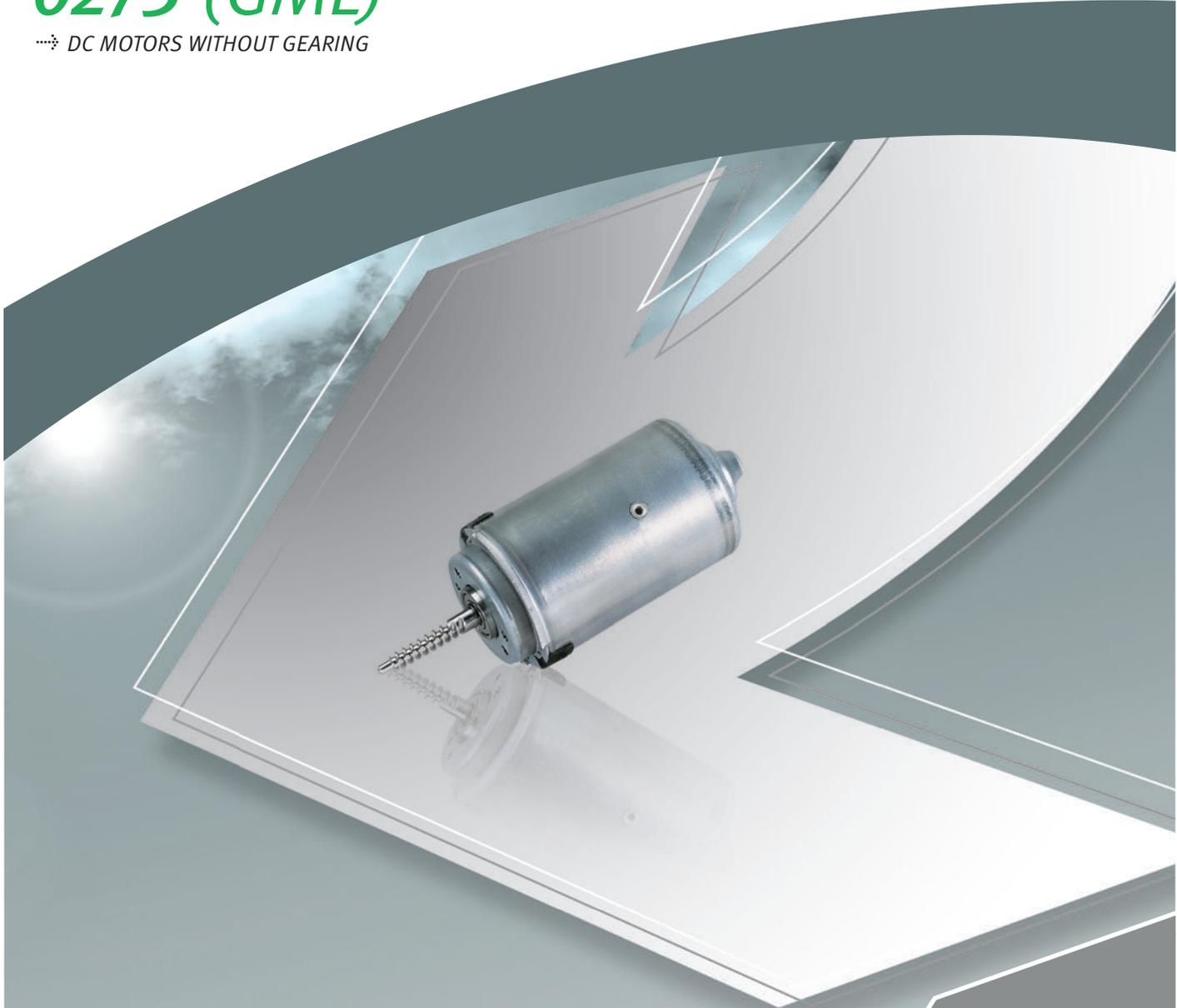

❖❖❖ TECHNICAL DESCRIPTION

Motorhousing:	deep drawn & corrosion protected
Excitation field:	permanent magnet
Type of gear mesh:	-
Gear housing:	-
Gear wheel material:	-
Lubrication:	grease
Mechanical interface:	steel shaft
Electric interface:	leads with connector
Sensor:	-
Thermal protection:	optional
EMC suppression:	optional

❖❖❖ INDUSTRIAL APPLICATION

Linear drives

❖❖❖ AUTOMOTIVE APPLICATION

Electric torque management,
Automated manual transmission

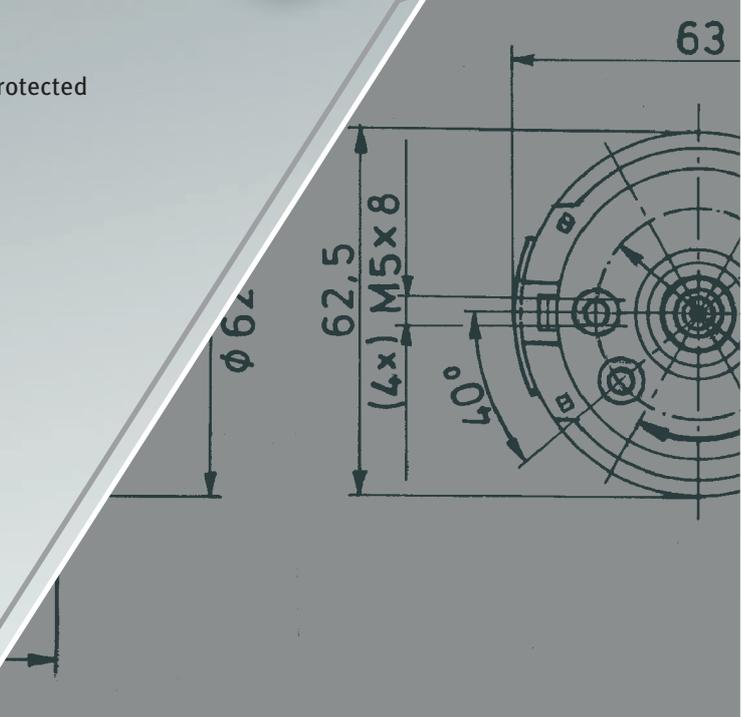

Design Data	
Commutation	Brushed
Direction of rotation	Bi-directional
Bearing type	A:Ball - B-Sleeve

Performance data		
Rated voltage [V]	U_N	36
Nominal torque [Nm]	M_N	0.20
No-load speed [min^{-1}]	n_0	4,100.0
Nominal power [W]	P_N	79.7
Nominal current [A]	I_N	3.0
Nominal force [kN]	F_N	0.00
Duty cycle		s1

Sensor data	
Pulses	0
Output channels	0

Other data	
Gear ratio	
Gear wheel material	
Suppression components	5 μ H, 10nF
Enclosure class	IP 30
Weight [kg]	1.150

Remarks:

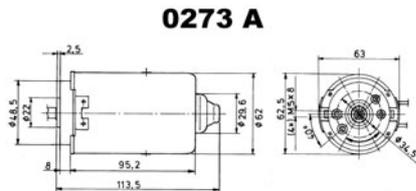

Motor picture

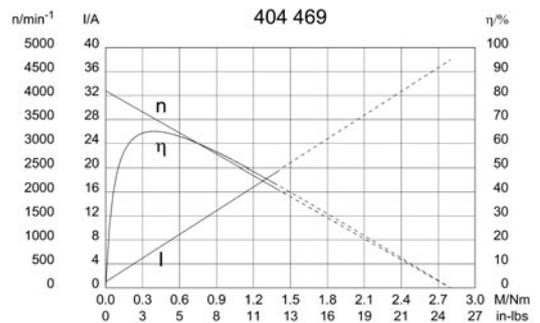

Output shaft drawing (W), Wiring diagrams (S) and Connector layout (K)

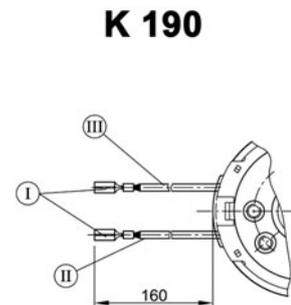
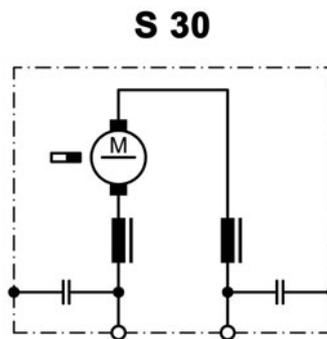
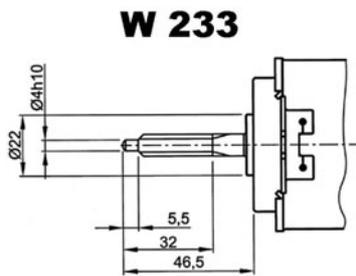

no of starts 2, lead angle 19°48'54", pressure angle 15°, module 1, pitch 3,141 mm (0,124")

I Receptacles for tabs 2,8 x 0,8 DIN 46 247
 II black
 III red

Design Data	
Commutation	Brushed
Direction of rotation	Bi-directional
Bearing type	A:Ball - B:Sleeve

Performance data		
Rated voltage [V]	U_N	24
Nominal torque [Nm]	M_N	0.30
No-load speed [min^{-1}]	n_0	4,000.0
Nominal power [W]	P_N	107
Nominal current [A]	I_N	7.5
Nominal force [kN]	F_N	0.00
Duty cycle		s1

Sensor data	
Pulses	0
Output channels	0

Other data	
Gear ratio	
Gear wheel material	
Suppression components	5 μ H, 10nF
Enclosure class	IP 30
Weight [kg]	1.150

Remarks:

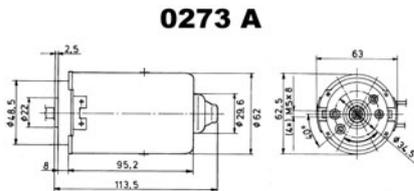

Motor picture

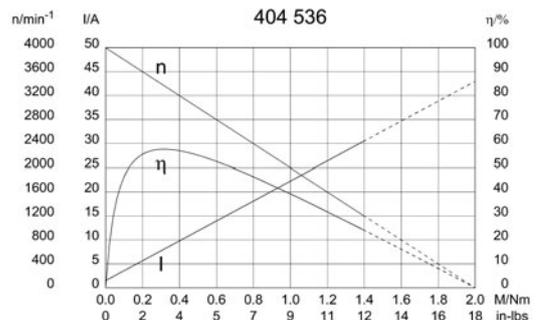

Output shaft drawing (W), Wiring diagrams (S) and Connector layout (K)

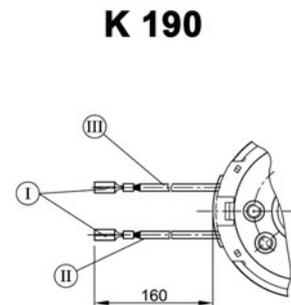
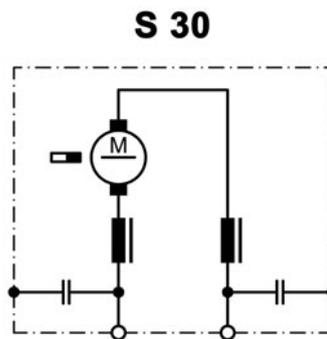
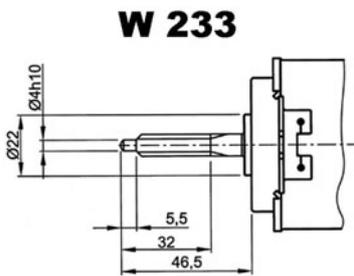

no of starts 2, lead angle 19°48'54", pressure angle 15°, module 1, pitch 3,141 mm (0,124")

I Receptacles for tabs 2,8 x 0,8 DIN 46 247
 II black
 III red

Design Data	
Commutation	Brushed
Direction of rotation	Bi-directional
Bearing type	A:Ball - B:Sleeve

Performance data		
Rated voltage [V]	U_N	12
Nominal torque [Nm]	M_N	0.20
No-load speed [min^{-1}]	n_0	3,750.0
Nominal power [W]	P_N	67.3
Nominal current [A]	I_N	7.0
Nominal force [kN]	F_N	0.00
Duty cycle		s1

Sensor data	
Pulses	0
Output channels	0

Other data	
Gear ratio	
Gear wheel material	
Suppression components	5 μ H, 10nF
Enclosure class	IP 30
Weight [kg]	1.150

Remarks:

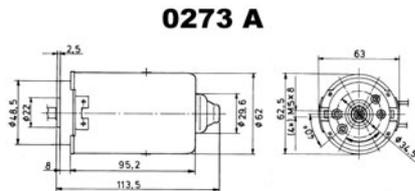

Motor picture

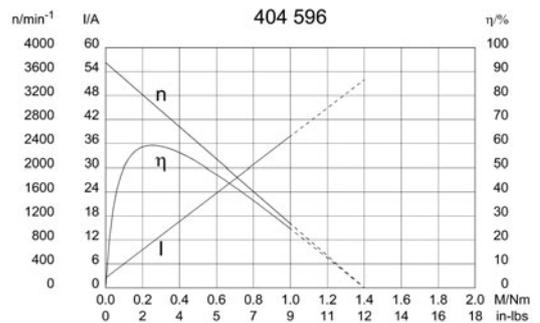

Output shaft drawing (W), Wiring diagrams (S) and Connector layout (K)

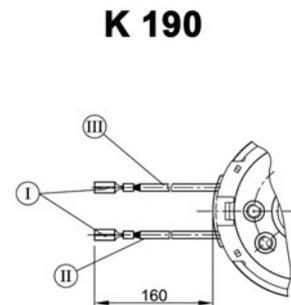
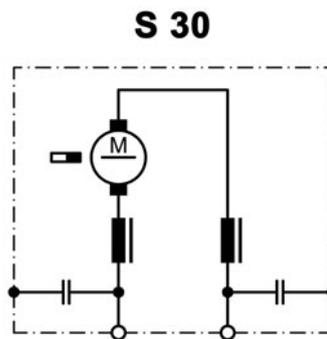
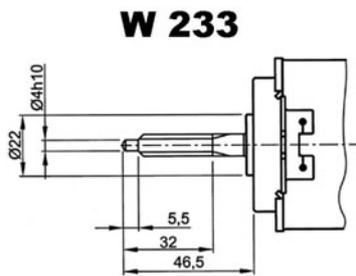

no of starts 2, lead angle 19°48'54", pressure angle 15°, module 1, pitch 3,141 mm (0,124")

I Receptacles for tabs 2,8 x 0,8 DIN 46 247
 II black
 III red

Design Data	
Commutation	Brushed
Direction of rotation	Bi-directional
Bearing type	A:Ball - B:Sleeve

Performance data		
Rated voltage [V]	U_N	24
Nominal torque [Nm]	M_N	0.30
No-load speed [min^{-1}]	n_0	3,800.0
Nominal power [W]	P_N	105
Nominal current [A]	I_N	5.0
Nominal force [kN]	F_N	0.00
Duty cycle		s1

Sensor data	
Pulses	0
Output channels	0

Other data	
Gear ratio	
Gear wheel material	
Suppression components	5 μ H, 10nF
Enclosure class	IP 30
Weight [kg]	1.100

Remarks:

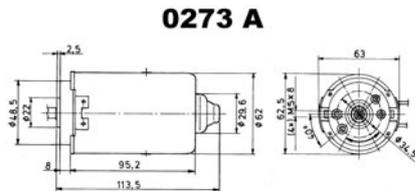

Motor picture



Characteristic curves

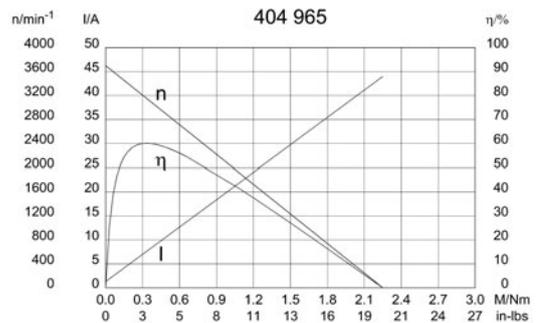

Output shaft drawing (W), Wiring diagrams (S) and Connector layout (K)

W 325

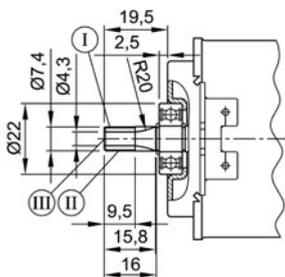

S 74

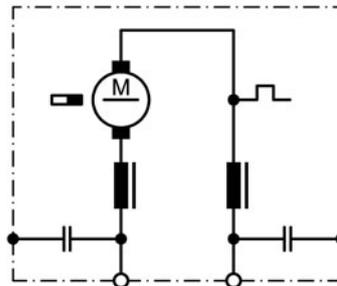

K 317

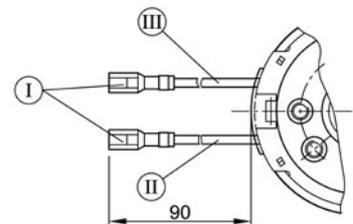

no of starts 7, lead angle 20°, pressure angle 20°, module 0,7, pitch 2,1991 mm (0,087"), induction hardened surface,

- I Receptacle for tabs 6,3 x 0,8
G&H 35040.213.011
- II red
- III green

Design Data	
Commutation	Brushed
Direction of rotation	Bi-directional
Bearing type	A:Ball - B:Sleeve

Performance data		
Rated voltage [V]	U_N	36
Nominal torque [Nm]	M_N	0.30
No-load speed [min^{-1}]	n_0	3,900.0
Nominal power [W]	P_N	109
Nominal current [A]	I_N	7.5
Nominal force [kN]	F_N	0.00
Duty cycle		s3

Sensor data	
Pulses	0
Output channels	0

Other data	
Gear ratio	
Gear wheel material	
Suppression components	5 μ H, 10nF
Enclosure class	IP 30
Weight [kg]	1.100

Remarks:

0273 A

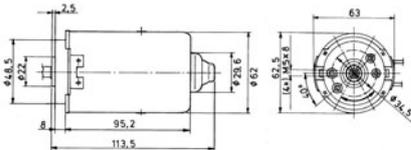

Motor picture



Characteristic curves

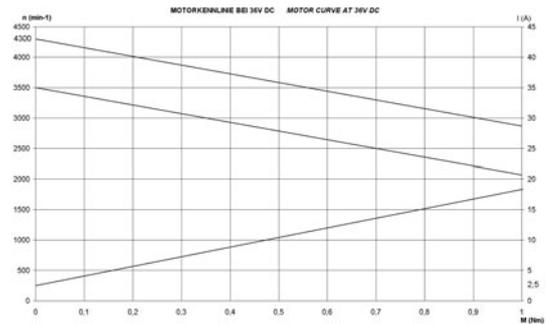

Output shaft drawing (W), Wiring diagrams (S) and Connector layout (K)

W 325

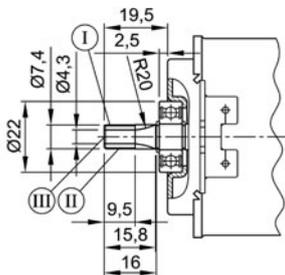

S 74

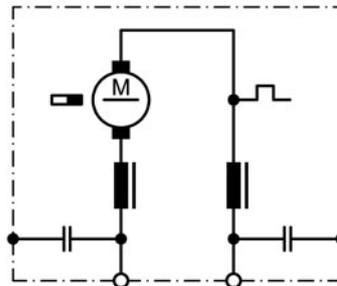

K 317

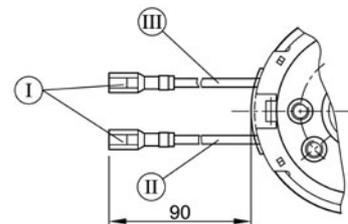

no of starts 7, lead angle 20°, pressure angle 20°, module 0,7, pitch 2,1991 mm (0,087"), induction hardened surface,

- I Receptacle for tabs 6,3 x 0,8
G&H 35040.213.011
- II red
- III green



NIDEC MOTORS & ACTUATORS ❖❖❖ MOTOR SERIES

0202 (GMAG)

❖❖❖ DC MOTORS WITH SPUR GEAR

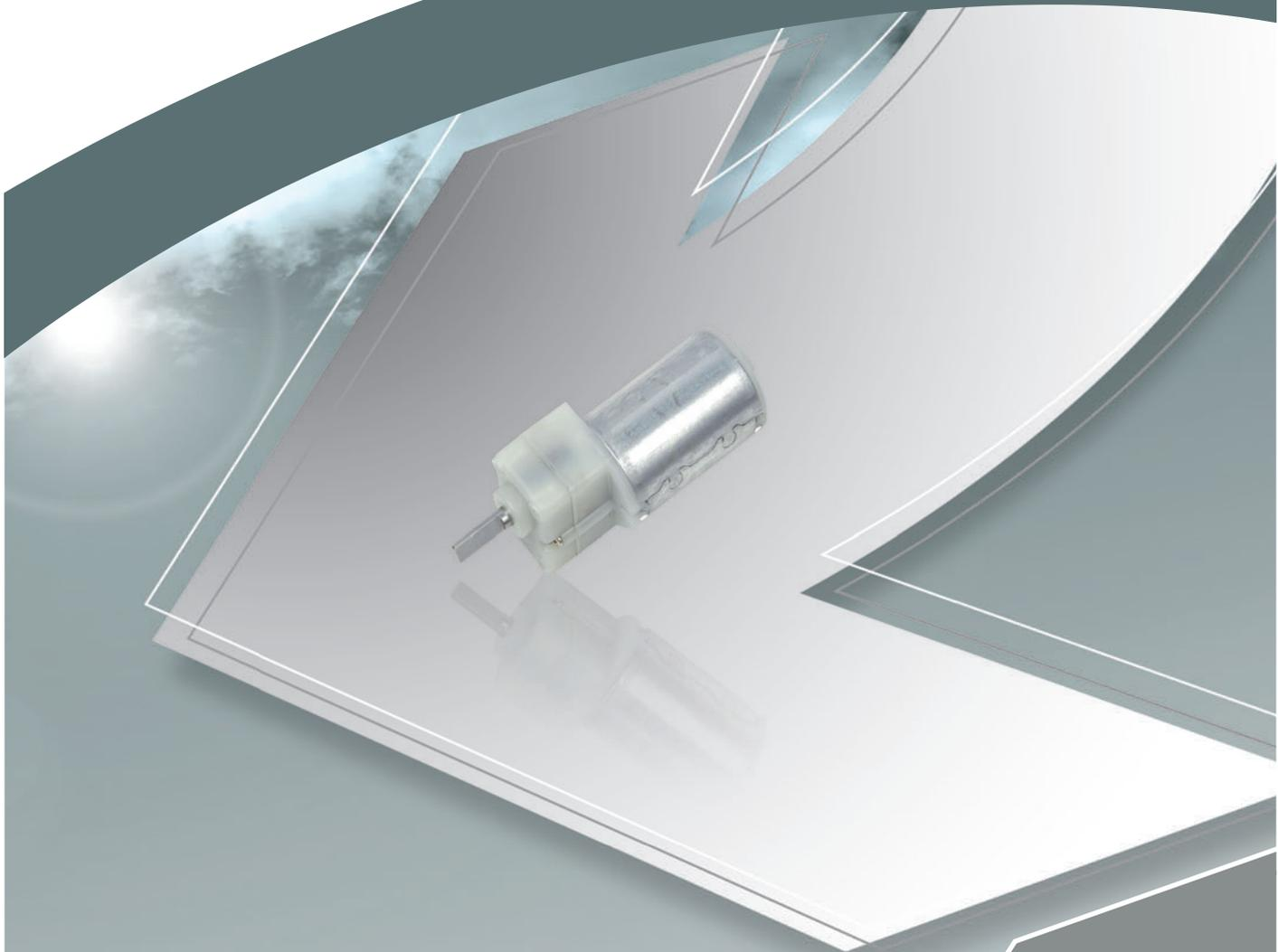

❖❖❖ TECHNICAL DESCRIPTION

Motorhousing:	sheet metal, rolled & corrosion protected
Excitation field:	permanent magnet
Type of gear mesh:	spur gear
Gear housing:	plastic
Gear wheel material:	steel or plastic
Lubrication:	grease
Mechanical interface:	steel shaft
Electric interface:	tinned leads or with connector
Sensor:	optional
Thermal protection:	optional
EMC suppression:	optional

❖❖❖ APPLICATION

Automatic machines, Constructional engineering
 Business machines, Laboratory appliances
 Medical appliances, Traffic & communications
 technology, Photographic/optical equipment

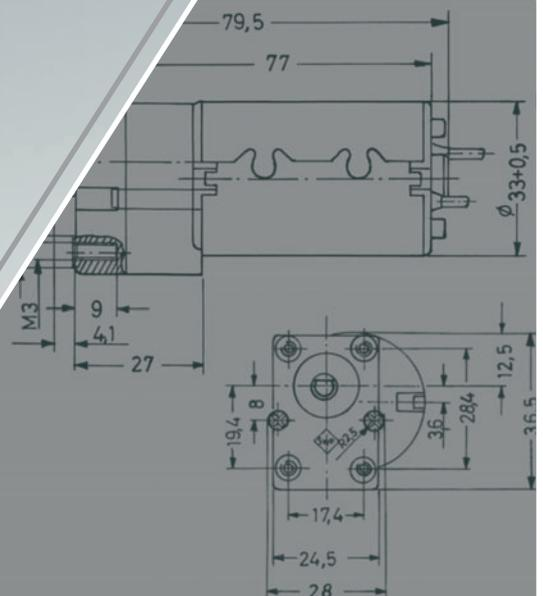

Design Data	
Commutation	Brushed
Direction of rotation	Bi-directional
Bearing type	

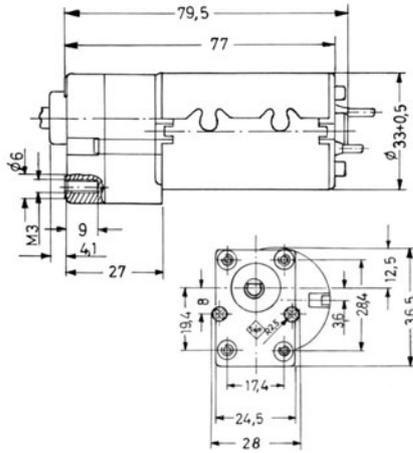

Performance data		
Rated voltage [V]	U_N	12
Nominal torque [Nm]	M_N	0.24
No-load speed [min^{-1}]	n_0	17.0
Nominal power [W]	P_N	0.37
Nominal current [A]	I_N	0.0
Nominal force [kN]	F_N	0.00
Duty cycle		s3

Sensor data	
Pulses	0
Output channels	0

Other data	
Gear ratio	109/1
Gear wheel material	
Suppression components	
Enclosure class	IP40
Weight [kg]	0.180

Remarks:

Motor picture



Characteristic curves

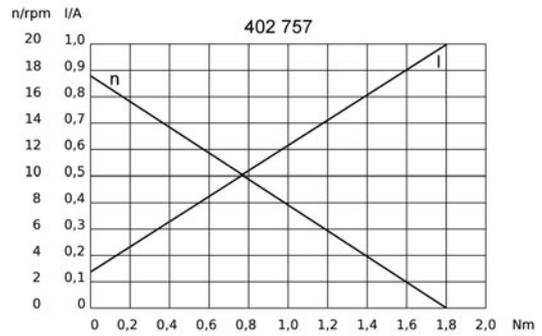

Output shaft drawing (W), Wiring diagrams (S) and Connector layout (K)

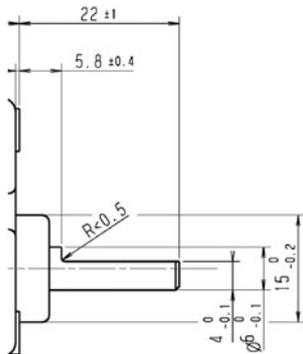

S 30

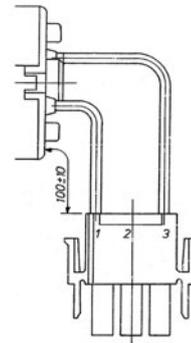
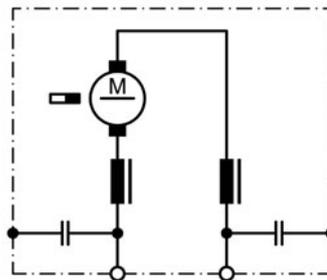

Design Data	
Commutation	Brushed
Direction of rotation	Bi-directional
Bearing type	

Performance data		
Rated voltage [V]	U_N	24
Nominal torque [Nm]	M_N	0.50
No-load speed [min^{-1}]	n_0	55.0
Nominal power [W]	P_N	2.56
Nominal current [A]	I_N	0.5
Nominal force [kN]	F_N	0.00
Duty cycle		s3

Sensor data	
Pulses	0
Output channels	0

Other data	
Gear ratio	109/1
Gear wheel material	
Suppression components	
Enclosure class	IP40
Weight [kg]	0.180

Remarks:

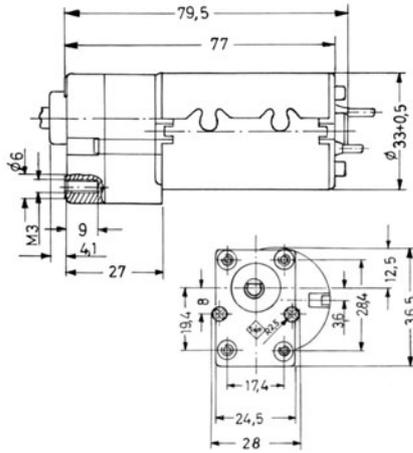

Motor picture



Characteristic curves

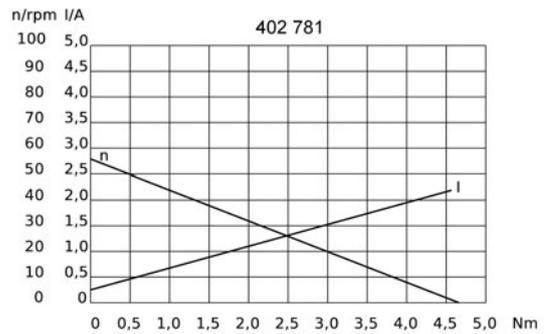

Output shaft drawing (W), Wiring diagrams (S) and Connector layout (K)

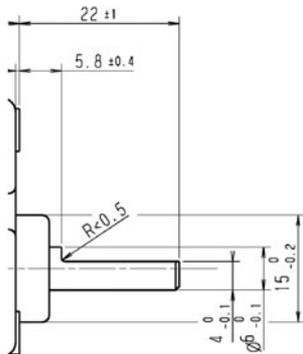

S 30

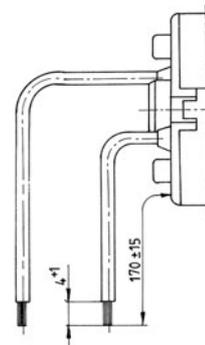
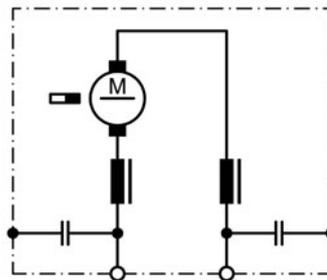

Design Data	
Commutation	Brushed
Direction of rotation	Bi-directional
Bearing type	

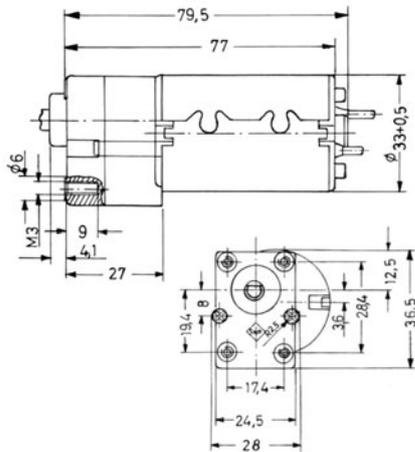

Performance data		
Rated voltage [V]	U_N	24
Nominal torque [Nm]	M_N	0.04
No-load speed [min^{-1}]	n_0	300.0
Nominal power [W]	P_N	1.07
Nominal current [A]	I_N	0.2
Nominal force [kN]	F_N	0.00
Duty cycle		s3

Sensor data	
Pulses	0
Output channels	0

Other data	
Gear ratio	9.7/1
Gear wheel material	
Suppression components	
Enclosure class	IP40
Weight [kg]	0.180

Remarks:

Motor picture



Characteristic curves

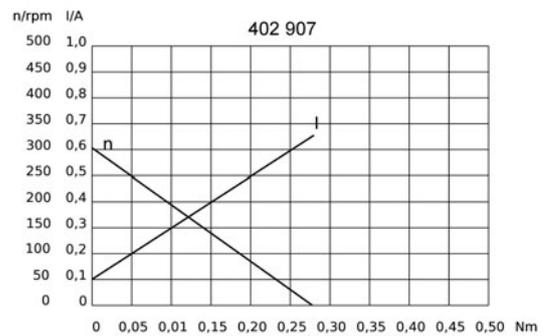

Output shaft drawing (W), Wiring diagrams (S) and Connector layout (K)

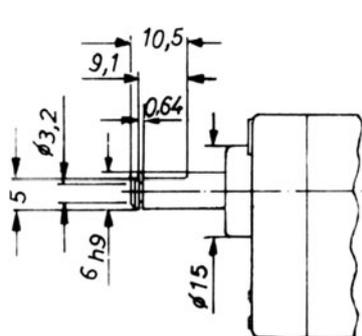

S 30

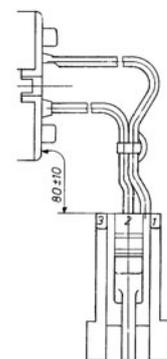
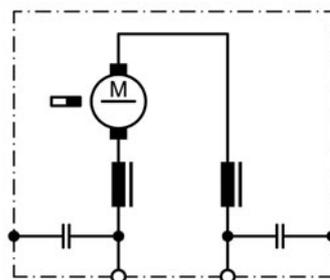

Connector Burndy
 Pins: SWM 1EF TV2
 Housing: SMS 2p-1

Design Data	
Commutation	Brushed
Direction of rotation	Bi-directional
Bearing type	

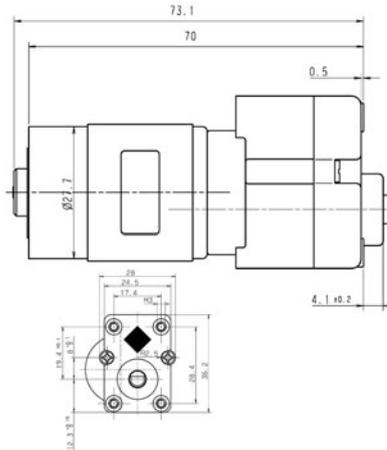

Motor picture



Performance data		
Rated voltage [V]	U_N	24
Nominal torque [Nm]	M_N	0.20
No-load speed [min^{-1}]	n_0	135.0
Nominal power [W]	P_N	2.26
Nominal current [A]	I_N	0.3
Nominal force [kN]	F_N	0.00
Duty cycle		s3

Sensor data	
Pulses	0
Output channels	0

Other data	
Gear ratio	43/1
Gear wheel material	
Suppression components	
Enclosure class	IP40
Weight [kg]	0.180

Remarks:

Characteristic curves

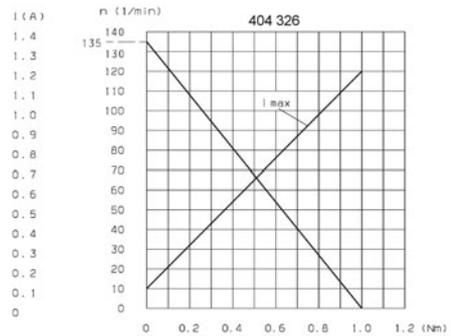

Output shaft drawing (W), Wiring diagrams (S) and Connector layout (K)

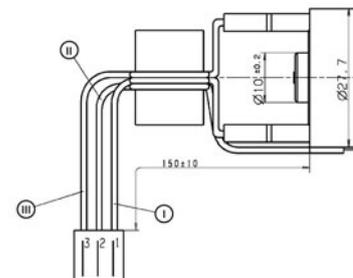
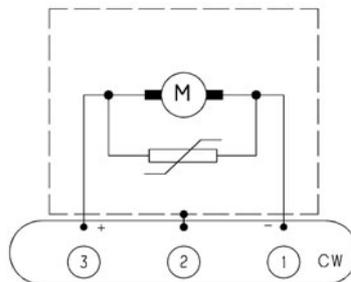
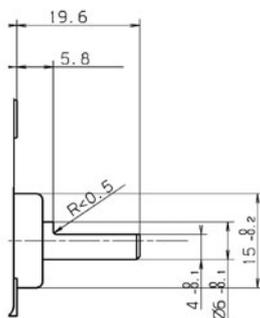

Housing: AMP-Nr.: 1-480 700-0
Pins: AMP-Nr.: 350 570-1
I: black
II: yellow/green
III: red

Design Data

Commutation	Brushed
Direction of rotation	Bi-directional
Bearing type	

Performance data

Rated voltage [V]	U_N	24
Nominal torque [Nm]	M_N	0.50
No-load speed [min^{-1}]	n_0	65.0
Nominal power [W]	P_N	2.84
Nominal current [A]	I_N	0.4
Nominal force [kN]	F_N	0.00
Duty cycle		s3

Sensor data

Pulses	0
Output channels	0

Other data

Gear ratio	109/1
Gear wheel material	
Suppression components	
Enclosure class	IP40
Weight [kg]	0.180

Remarks:

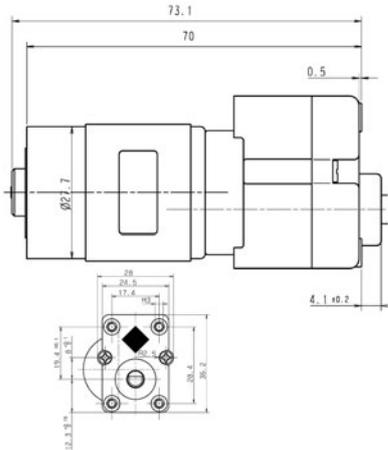

Motor picture



Characteristic curves

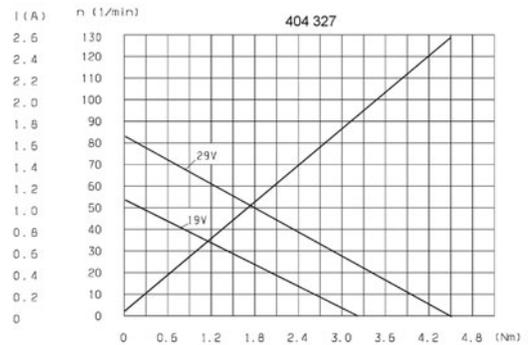

Output shaft drawing (W), Wiring diagrams (S) and Connector layout (K)

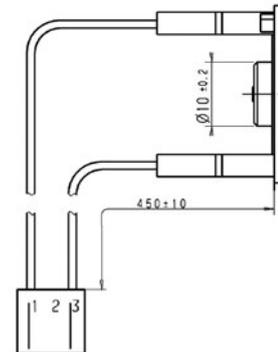
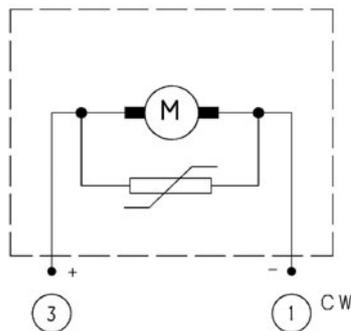
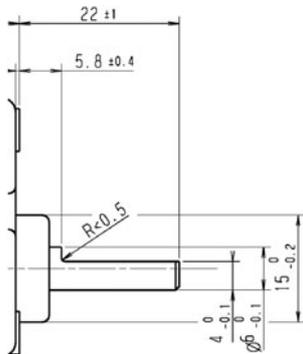

Housing: AMP-Nr. 1-480 700-0
Pins: AMP-Nr. 350 687-1



NIDEC MOTORS & ACTUATORS ❖❖❖ MOTOR SERIES

0231 (GMPI)

❖❖❖ DC MOTORS WITH SPUR GEAR



❖❖❖ TECHNICAL DESCRIPTION

Motorhousing:	sheet metal, rolled & corrosion protected
Excitation field:	permanent magnet
Type of gear mesh:	spur gear
Gear housing:	plastic
Gear wheel material:	plastic
Lubrication:	grease
Mechanical interface:	steel shaft
Electric interface:	connector or leads with connector
Sensor:	optional
Thermal protection:	optional
EMC suppression:	optional

❖❖❖ INDUSTRIAL APPLICATION

Linear actuators, home automation

❖❖❖ AUTOMOTIVE APPLICATION

Spoiler adjustment

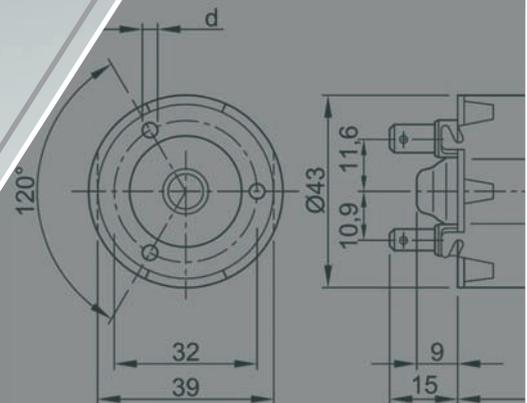

Design Data	
Commutation	Brushed
Direction of rotation	Bi-directional
Bearing type	A:Sleeve - B:Sleeve

0231 A

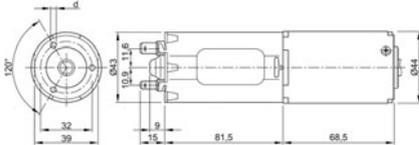

Performance data		
Rated voltage [V]	U_N	24
Nominal torque [Nm]	M_N	4.00
No-load speed [min^{-1}]	n_0	210.0
Nominal power [W]	P_N	72.0
Nominal current [A]	I_N	7.0
Nominal force [kN]	F_N	0.00
Duty cycle		s3

Sensor data	
Pulses	0
Output channels	0

Other data	
Gear ratio	39.7/1
Gear wheel material	plastic
Suppression components	7,5 μ H, 1nF
Enclosure class	IP30
Weight [kg]	0.630

Remarks: d = 3,3mm, for selftapping screw 4mm (shape Remform)

Motor picture



Characteristic curves

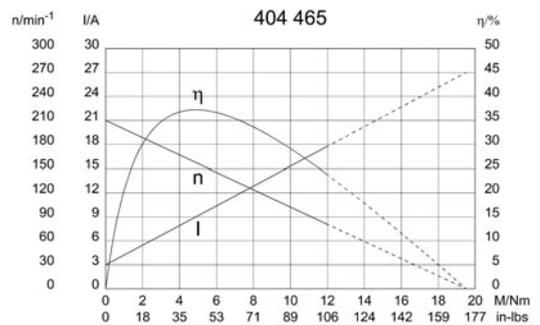

Output shaft drawing (W), Wiring diagrams (S) and Connector layout (K)

W 268

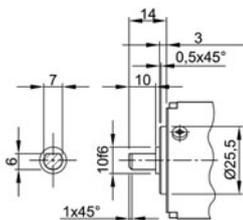

S 30

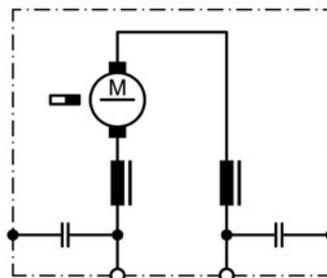

K 117

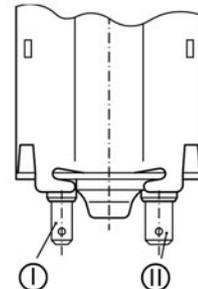

I Blade terminal ends 4,8 x 0,8 DIN 46 244
 II Blade terminal ends 6,3 x 0,8 DIN 46 244

Design Data	
Commutation	Brushed
Direction of rotation	Bi-directional
Bearing type	A:Sleeve - B:Sleeve

0231 C

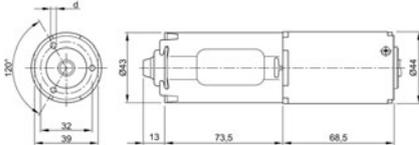

Performance data		
Rated voltage [V]	U_N	24
Nominal torque [Nm]	M_N	1.50
No-load speed [min^{-1}]	n_0	178.0
Nominal power [W]	P_N	20.0
Nominal current [A]	I_N	3.0
Nominal force [kN]	F_N	0.00
Duty cycle		s3

Sensor data	
Pulses	20
Output channels	2

Other data	
Gear ratio	20/1
Gear wheel material	plastic
Suppression components	4 μ H, 1nF
Enclosure class	IP 30
Weight [kg]	0.750

Remarks: d = 3,3mm, for self-cutting screw 4mm (shape Remform)

Characteristic curves

Motor picture

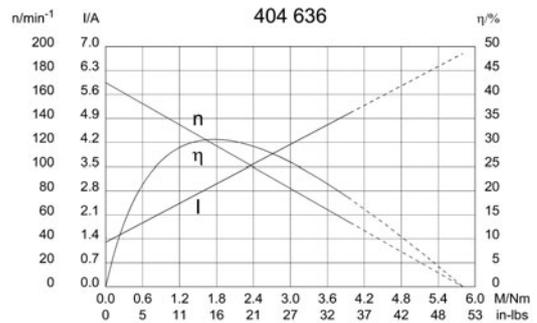

Output shaft drawing (W), Wiring diagrams (S) and Connector layout (K)

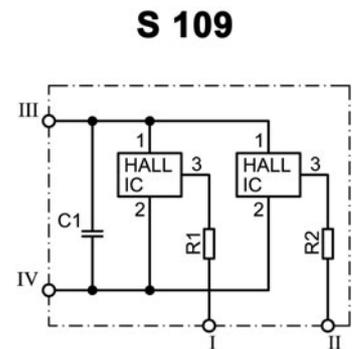
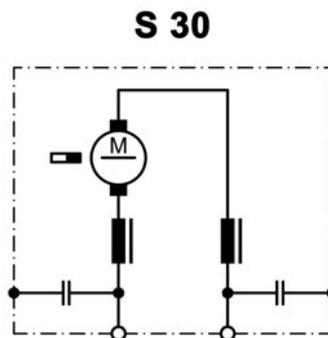
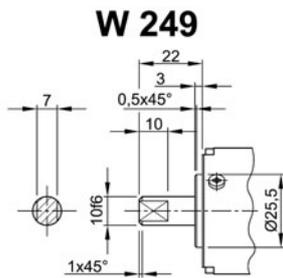

- I Terminal 1, OUT A1, grey
- II Terminal 2, OUT A2, black
- III Terminal 3, +, white
- IV Terminal 4, -, red

Design Data	
Commutation	Brushed
Direction of rotation	Bi-directional
Bearing type	sleeve bearing

0231 B

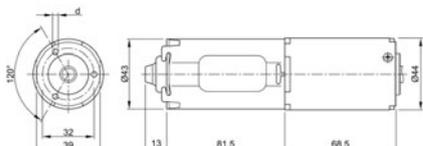

Performance data		
Rated voltage [V]	U_N	24
Nominal torque [Nm]	M_N	4.00
No-load speed [min^{-1}]	n_0	200.0
Nominal power [W]	P_N	69.8
Nominal current [A]	I_N	8.0
Nominal force [kN]	F_N	0.00
Duty cycle		s2

Sensor data	
Pulses	39
Output channels	2

Other data	
Gear ratio	39.7/1
Gear wheel material	plastic
Suppression components	4,0 μ H, 1nF
Enclosure class	IP 30
Weight [kg]	0.650

Remarks: d = 3,3mm, for self-cutting screw 4mm

Motor picture



Characteristic curves

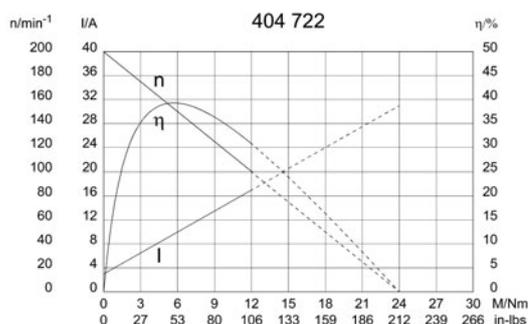

Output shaft drawing (W), Wiring diagrams (S) and Connector layout (K)

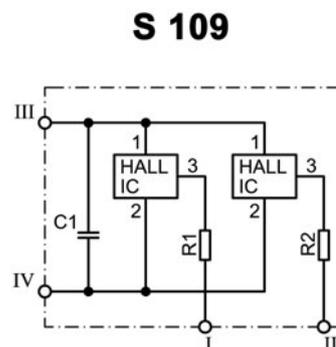
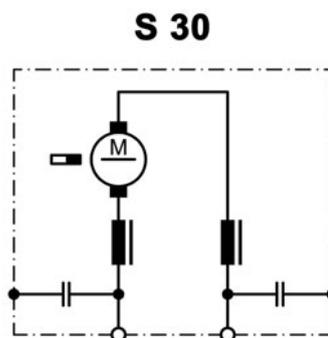
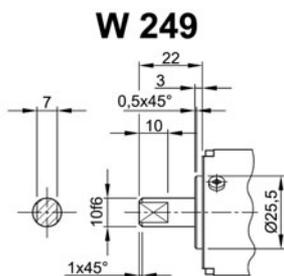

- I Terminal 1, OUT A1, grey
- II Terminal 2, OUT A2, black
- III Terminal 3, +, white
- IV Terminal 4, -, red

Design Data	
Commutation	Brushed
Direction of rotation	Bi-directional
Bearing type	A:Sleeve - B:Sleeve

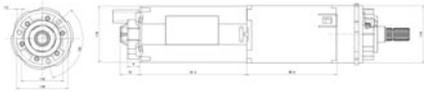

Performance data		
Rated voltage [V]	U_N	12
Nominal torque [Nm]	M_N	10.0
No-load speed [min^{-1}]	n_0	40.0
Nominal power [W]	P_N	34.4
Nominal current [A]	I_N	8.0
Nominal force [kN]	F_N	0.00
Duty cycle		s3

Sensor data	
Pulses	116
Output channels	1

Other data	
Gear ratio	116/1
Gear wheel material	plastic
Suppression components	2,5 μ H, 47nF, ()
Enclosure class	IP 30
Weight [kg]	0.800

Remarks:

Motor picture



Characteristic curves

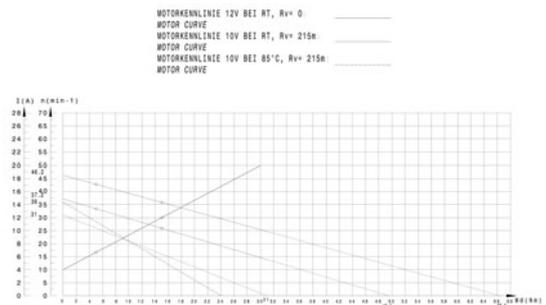

Output shaft drawing (W), Wiring diagrams (S) and Connector layout (K)

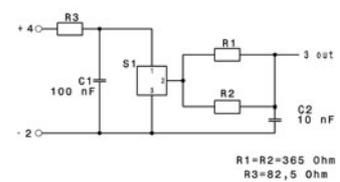
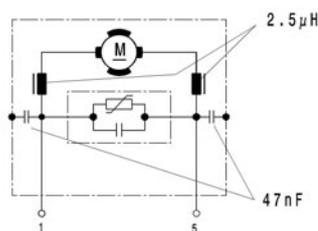
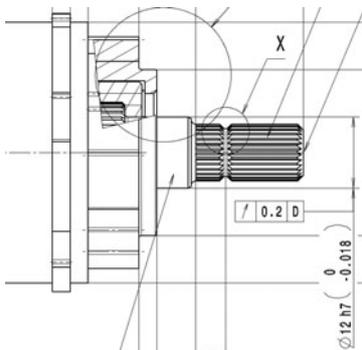



NIDEC MOTORS & ACTUATORS ❖❖❖ MOTOR SERIES

0320 (GMPD)

❖❖❖ DC MOTORS WITH WORM GEAR

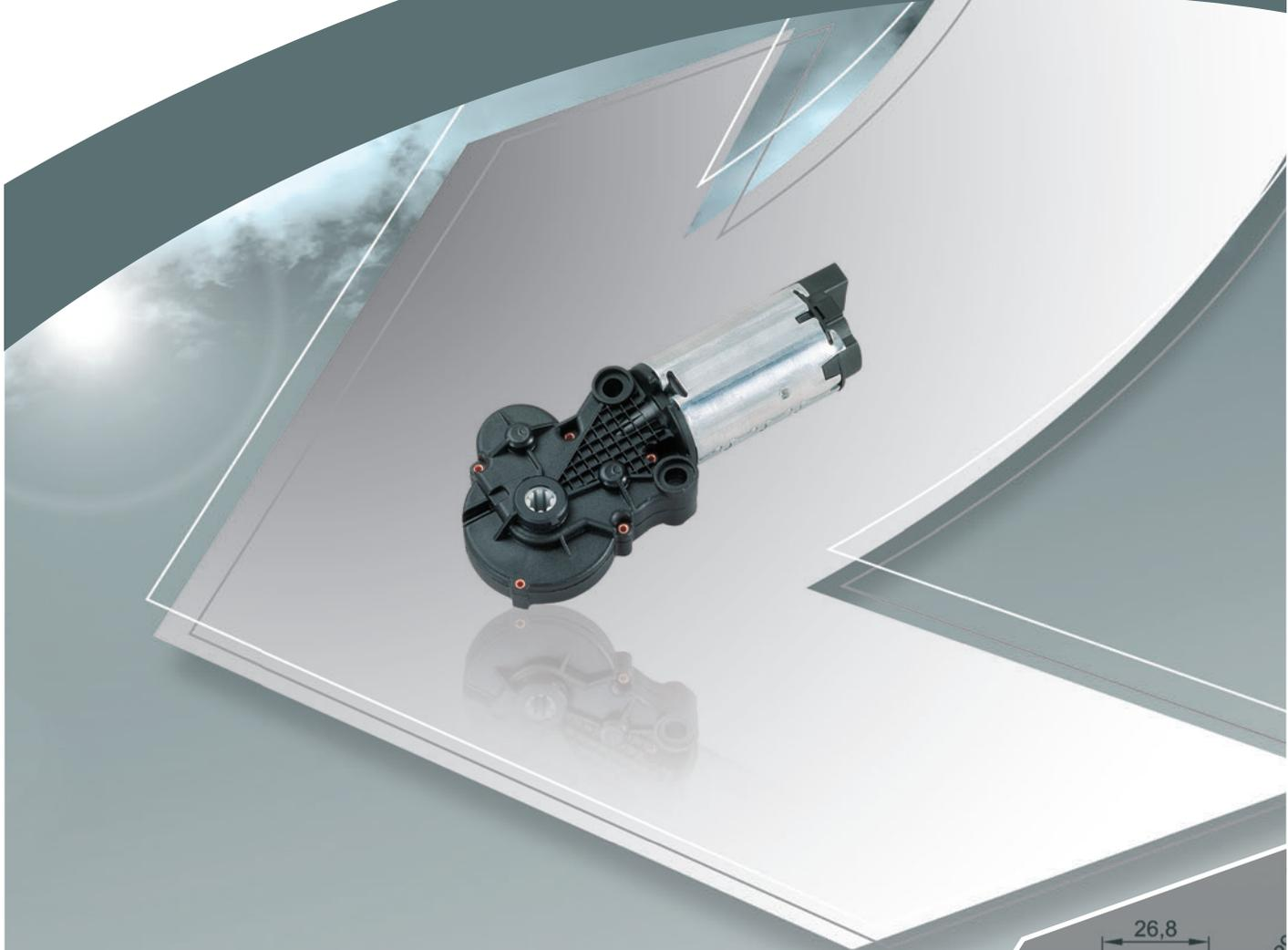

❖❖❖ TECHNICAL DESCRIPTION

Motorhousing:	sheet metal, rolled & corrosion protected
Excitation field:	permanent magnet
Type of gear mesh:	combination of worm and spur gear
Gear housing:	plastic
Gear wheel material:	plastic
Lubrication:	grease
Mechanical interface:	hollow shaft with profile
Electric interface:	connector or leads with connector
Sensor:	optional
Thermal protection:	optional
EMC suppression:	optional

❖❖❖ INDUSTRIAL APPLICATION

Machine construction

❖❖❖ AUTOMOTIVE APPLICATION

Seat Recline Adjustment



Design Data	
Commutation	Brushed
Direction of rotation	Bi-directional
Bearing type	A:Sleeve - B:Sleeve

Performance data		
Rated voltage [V]	U_N	12
Nominal torque [Nm]	M_N	3.00
No-load speed [min^{-1}]	n_0	21.0
Nominal power [W]	P_N	5.59
Nominal current [A]	I_N	3.5
Nominal force [kN]	F_N	0.00
Duty cycle		s3

0320 BR

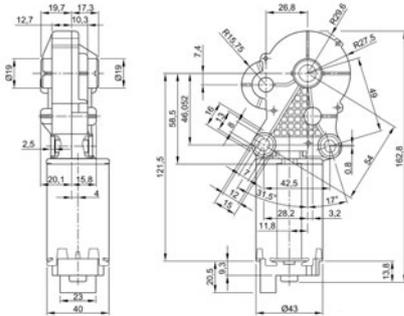

Sensor data	
Pulses	0
Output channels	0

Other data	
Gear ratio	210/1
Gear wheel material	plastic
Suppression components	5,5 μ H, 47nF, (0,47 μ F)
Enclosure class	IP 40
Weight [kg]	0.440

Remarks:

Motor picture

Characteristic curves

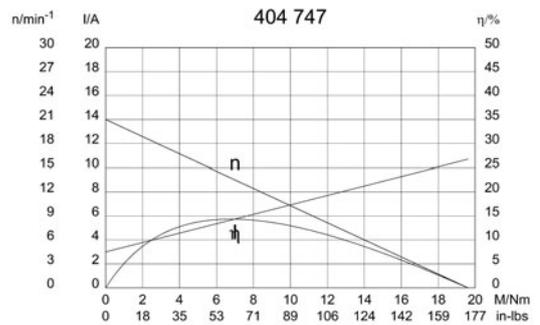

Output shaft drawing (W), Wiring diagrams (S) and Connector layout (K)

W 270

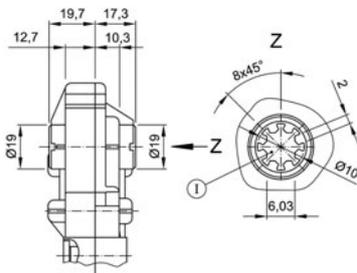

I through profile

S 93

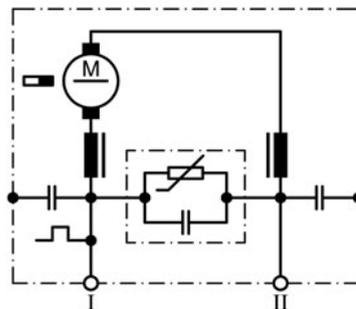

I Terminal 1
 II Terminal 5

K 220

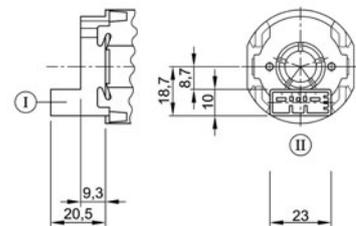

Connector TYCO C-208-15621 (Z) mating with:
Connector housing 1379217-3 & cover
 1379218-2
www.tycoelectronics.com

Design Data	
Commutation	Brushed
Direction of rotation	Bi-directional
Bearing type	A:Sleeve - B:Sleeve

Performance data		
Rated voltage [V]	U_N	12
Nominal torque [Nm]	M_N	3.00
No-load speed [min^{-1}]	n_0	21.0
Nominal power [W]	P_N	5.59
Nominal current [A]	I_N	3.5
Nominal force [kN]	F_N	0.00
Duty cycle		s3

0320 BR

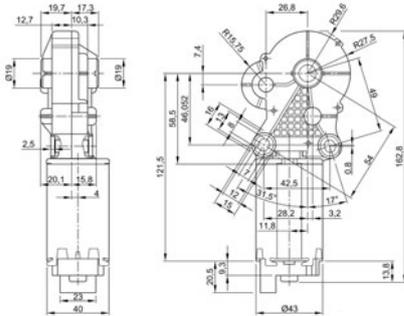

Sensor data	
Pulses	210
Output channels	1

Other data	
Gear ratio	210/1
Gear wheel material	plastic
Suppression components	5,5 μ H, 47nF, (0,47 μ F)
Enclosure class	IP 40
Weight [kg]	0.440

Remarks:

Motor picture



Characteristic curves

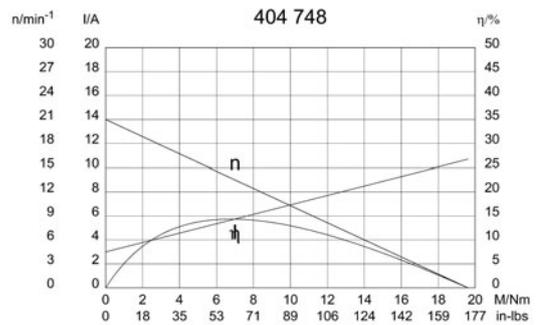

Output shaft drawing (W), Wiring diagrams (S) and Connector layout (K)

W 270

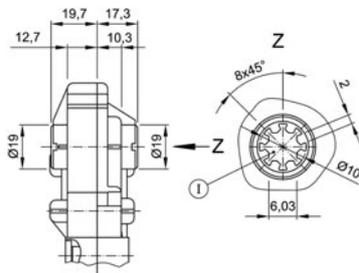

I through profile

S 86

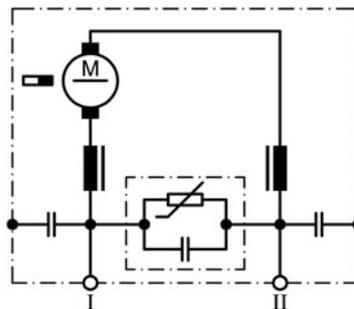

I Terminal 1
 II Terminal 5

S 85

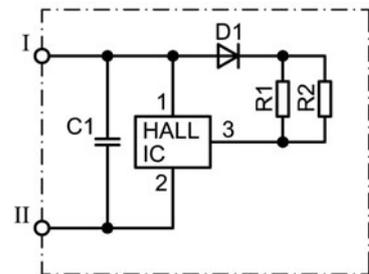

I Terminal 4, Hall-IC +
 II Terminal 2, Hall-IC -

Design Data	
Commutation	Brushed
Direction of rotation	Bi-directional
Bearing type	A:Sleeve - B:Sleeve

Performance data		
Rated voltage [V]	U_N	24
Nominal torque [Nm]	M_N	4.00
No-load speed [min^{-1}]	n_0	22.0
Nominal power [W]	P_N	7.54
Nominal current [A]	I_N	1.8
Nominal force [kN]	F_N	0.00
Duty cycle		s3

0320 AR

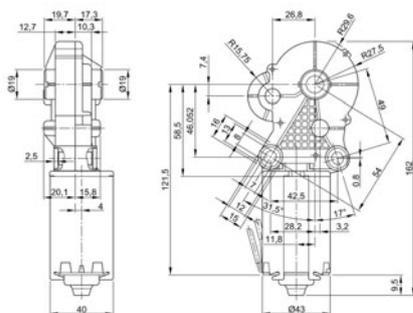

Sensor data	
Pulses	0
Output channels	0

Other data	
Gear ratio	210/1
Gear wheel material	plastic
Suppression components	7,5 μ H, 47nF, (0,47 μ F)
Enclosure class	IP 40
Weight [kg]	0.440

Remarks:

Motor picture



Characteristic curves

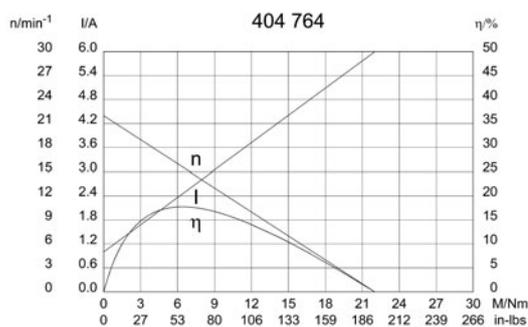

Output shaft drawing (W), Wiring diagrams (S) and Connector layout (K)

W 224

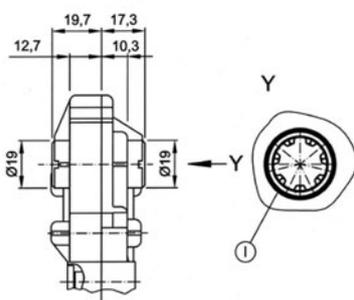

I through Profile KRC 316928 AEIZ 01

S 103

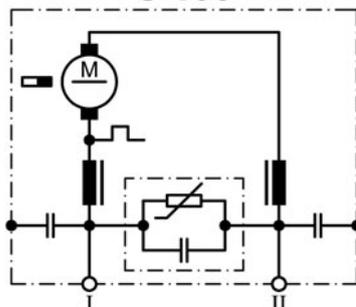

I Terminal 1, black
 II Terminal 2, blue

K 227

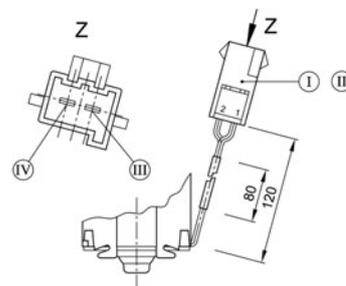

tap housing 365057-1, timer contacts 928781-5
 mating with receptacle housing 365058-1,
 timer contacts 927768-1
 1 black motor, 2 blue motor

Design Data	
Commutation	Brushed
Direction of rotation	Bi-directional
Bearing type	A:Sleeve - B:Sleeve

Performance data		
Rated voltage [V]	U_N	12
Nominal torque [Nm]	M_N	2.00
No-load speed [min^{-1}]	n_0	21.0
Nominal power [W]	P_N	3.95
Nominal current [A]	I_N	3.0
Nominal force [kN]	F_N	0.00
Duty cycle		s3

0320 BR

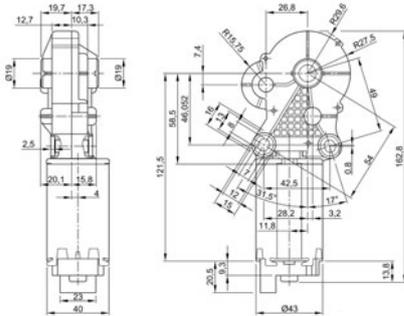

Sensor data	
Pulses	0
Output channels	0

Other data	
Gear ratio	210/1
Gear wheel material	plastic
Suppression components	5,5 μ H, 47nF
Enclosure class	IP 40
Weight [kg]	0.440

Remarks:

Motor picture



Characteristic curves

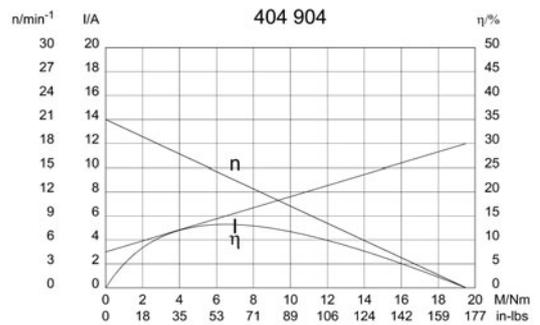

Output shaft drawing (W), Wiring diagrams (S) and Connector layout (K)

W 224

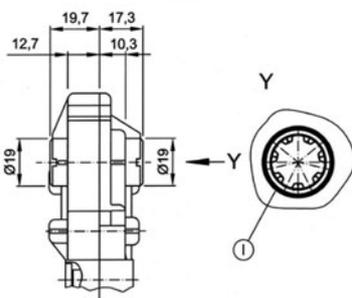

I through Profile KRC 316928 AEIZ 01

S 93

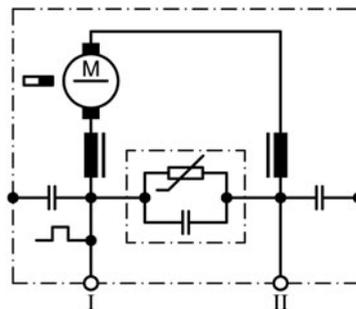

I Terminal 1
 II Terminal 5

K 220

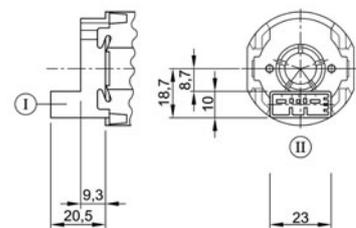

Connector TYCO C-208-15621 (Z) mating with:
Connector housing 1379217-3 & cover
 1379218-2
www.tycoelectronics.com

Design Data	
Commutation	Brushed
Direction of rotation	Bi-directional
Bearing type	

Performance data		
Rated voltage [V]	U_N	12
Nominal torque [Nm]	M_N	2.00
No-load speed [min^{-1}]	n_0	21.0
Nominal power [W]	P_N	3.92
Nominal current [A]	I_N	3.5
Nominal force [kN]	F_N	0.00
Duty cycle		s3

0320 BR

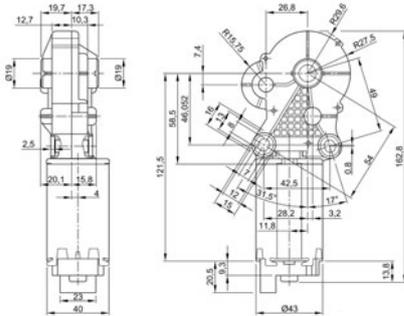

Sensor data	
Pulses	210
Output channels	1

Other data	
Gear ratio	210/1
Gear wheel material	plastic
Suppression components	""
Enclosure class	IP 40
Weight [kg]	0.440

Remarks: Plastic gearbox

Motor picture

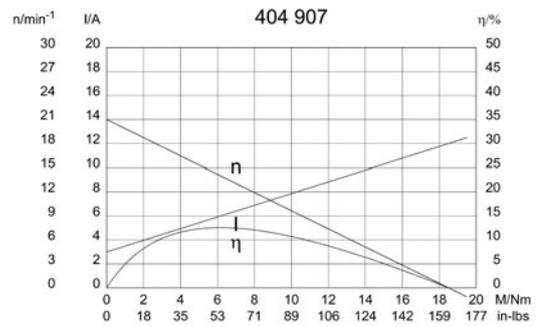

Output shaft drawing (W), Wiring diagrams (S) and Connector layout (K)

W 224

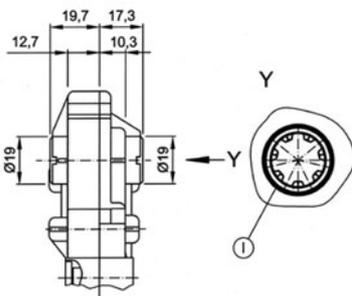

S 138

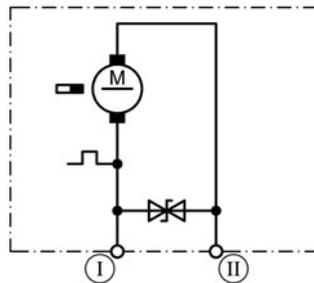

S 140

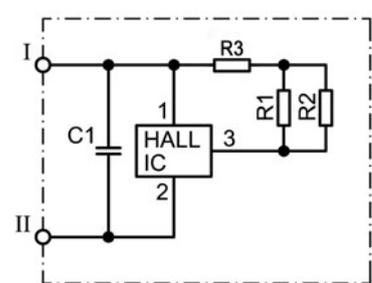

I through Profile KRC 316928 AEIZ 01

I Terminal 1
 II Terminal 5

I Terminal 4; Hall-IC +
 II Terminal 2; Hall-IC -

Design Data	
Commutation	Brushed
Direction of rotation	Bi-directional
Bearing type	A:Sleeve - B:Sleeve

Performance data		
Rated voltage [V]	U_N	12
Nominal torque [Nm]	M_N	2.00
No-load speed [min^{-1}]	n_0	22.0
Nominal power [W]	P_N	4.10
Nominal current [A]	I_N	4.0
Nominal force [kN]	F_N	0.00
Duty cycle	s3	

0320 BR

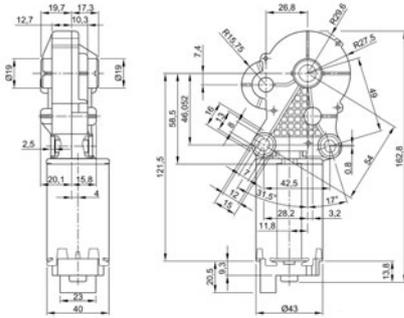

Sensor data	
Pulses	0
Output channels	0

Other data	
Gear ratio	210/1
Gear wheel material	plastic
Suppression components	7,5 μ H, 1nF
Enclosure class	IP40
Weight [kg]	0.440

Remarks:

Motor picture



Characteristic curves

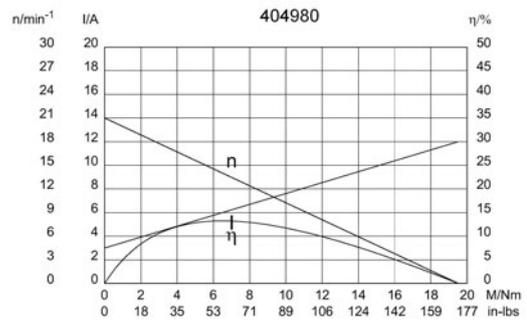

Output shaft drawing (W), Wiring diagrams (S) and Connector layout (K)

W 270

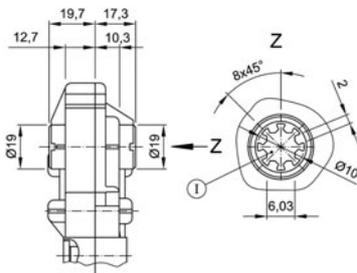

I through profile

S 86

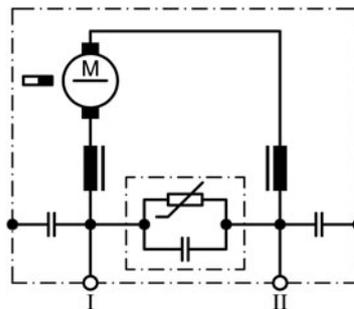

I Terminal 1
II Terminal 5

K 220

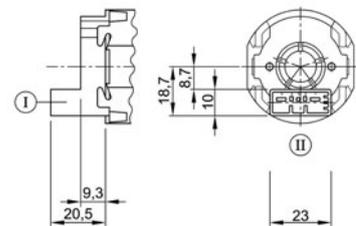

Connector TYCO C-208-15621 (Z) mating with:
Connector housing 1379217-3 & cover 1379218-2

www.tycoelectronics.com

Design Data	
Commutation	Brushed
Direction of rotation	Bi-directional
Bearing type	A:Sleeve - B:Sleeve

Performance data		
Rated voltage [V]	U_N	24
Nominal torque [Nm]	M_N	4.00
No-load speed [min^{-1}]	n_0	20.0
Nominal power [W]	P_N	6.70
Nominal current [A]	I_N	2.0
Nominal force [kN]	F_N	0.00
Duty cycle		s3

0320 AR

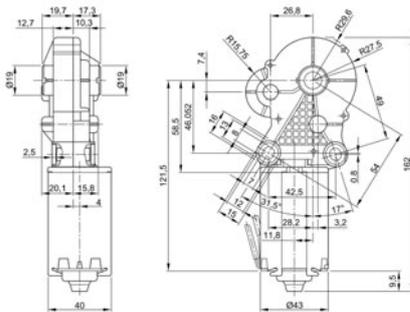

Sensor data	
Pulses	0
Output channels	0

Other data	
Gear ratio	246.75/1
Gear wheel material	plastic
Suppression components	7,5 μ , 47nF
Enclosure class	IP 40
Weight [kg]	0.440

Remarks:

Motor picture



Characteristic curves

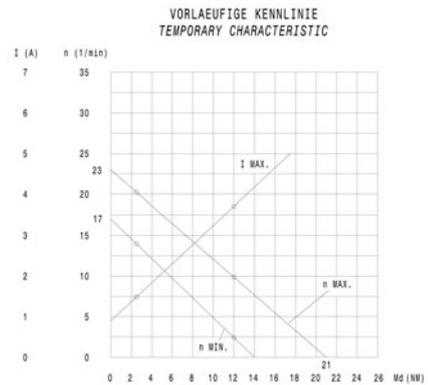

Output shaft drawing (W), Wiring diagrams (S) and Connector layout (K)

W 224

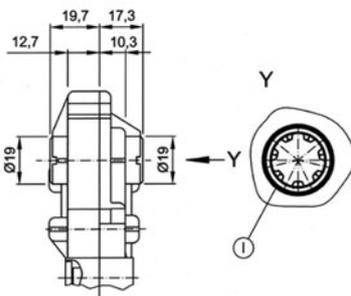

S 74

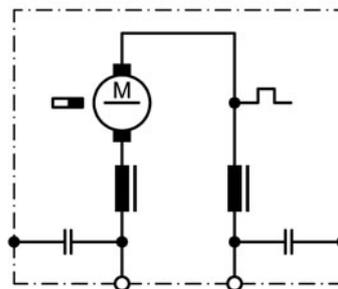

K 227

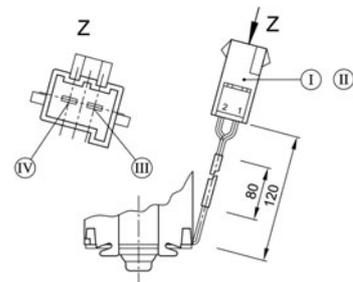

I through Profile KRC 316928 AEIZ 01

tap housing 365057-1, timer contacts 928781-5
 mating with receptacle housing 365058-1,
 timer contacts 927768-1
 1 black motor, 2 blue motor



NIDEC MOTORS & ACTUATORS ❖❖❖ MOTOR SERIES

0225 (GMPG)

❖❖❖ DC MOTORS WITH WORM GEAR

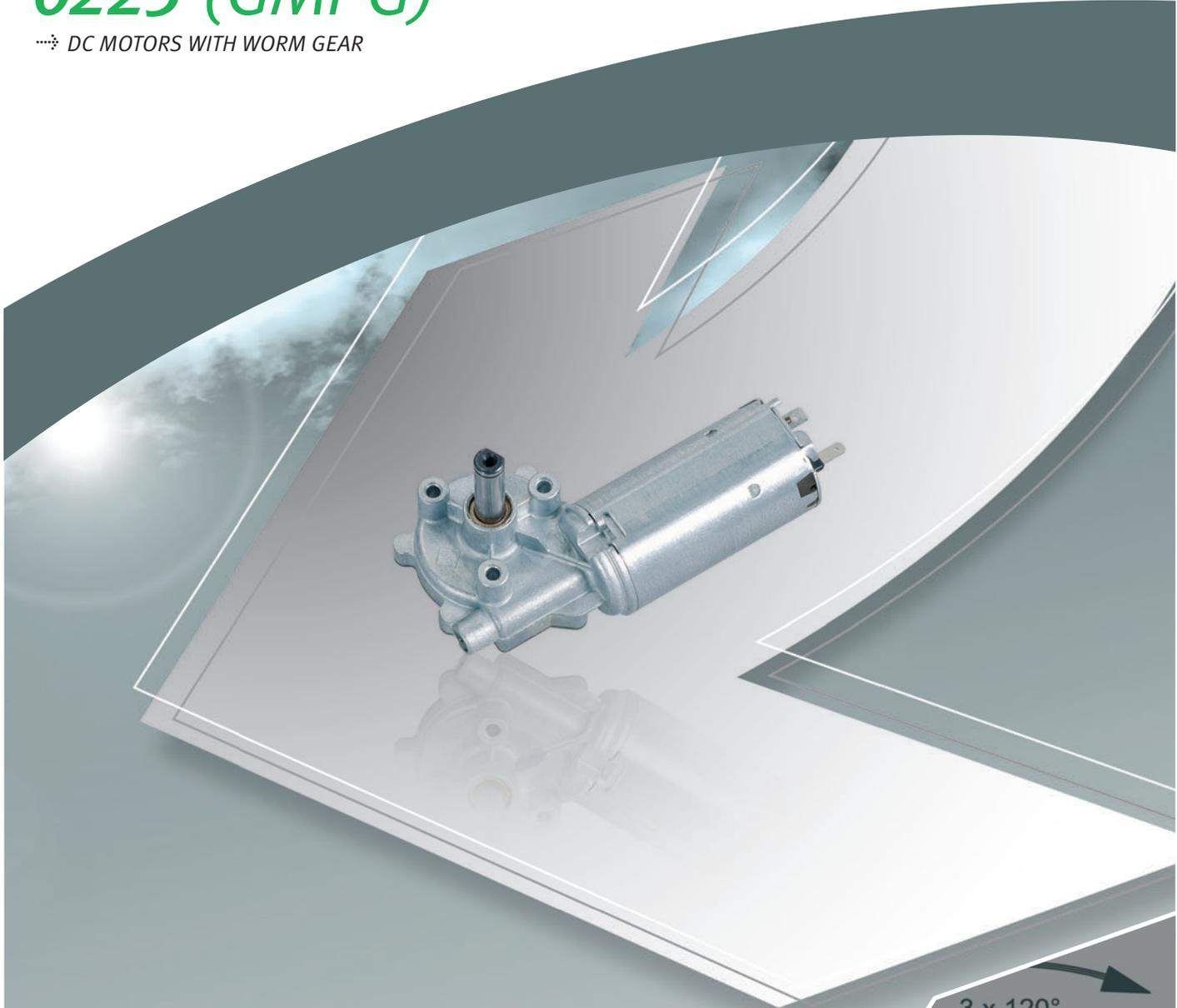

❖❖❖ TECHNICAL DESCRIPTION

Motorhousing:	sheet metal, rolled & corrosion protected
Excitation field:	permanent magnet
Type of gear mesh:	worm gear
Gear housing:	zinc die cast
Gear wheel material:	plastic
Lubrication:	grease
Mechanical interface:	steel shaft or hollow shaft with profile
Electric interface:	connector or leads with connector
Sensor:	optional
Thermal protection:	optional
EMC suppression:	optional

❖❖❖ INDUSTRIAL APPLICATION

Catering, Office machines, Furniture Adjustment, Machine Construction

❖❖❖ AUTOMOTIVE APPLICATION

Sunroof adjustment

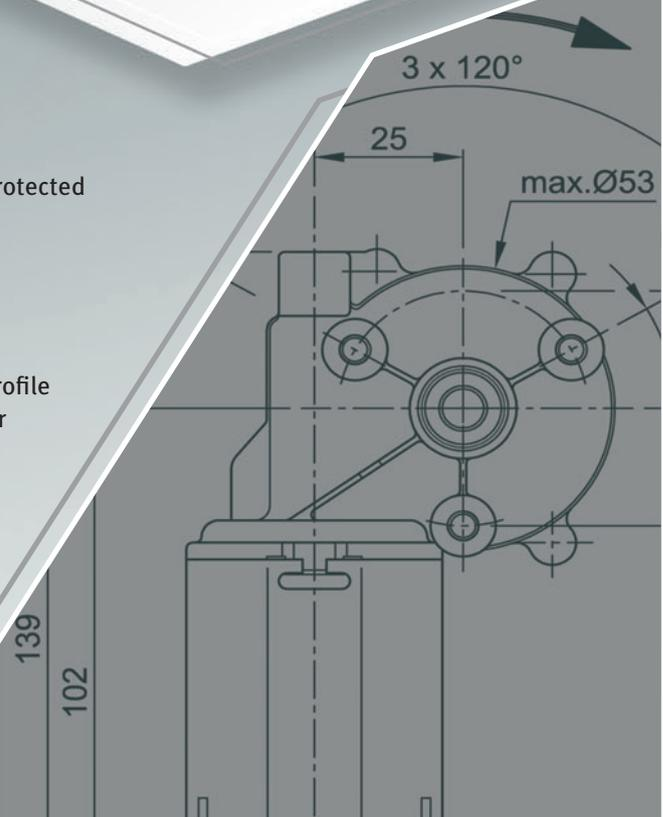

Design Data	
Commutation	Brushed
Direction of rotation	Bi-directional
Bearing type	A:Sleeve - B:Sleeve

Performance data		
Rated voltage [V]	U_N	24
Nominal torque [Nm]	M_N	1.00
No-load speed [min^{-1}]	n_0	80.0
Nominal power [W]	P_N	7.33
Nominal current [A]	I_N	1.5
Nominal force [kN]	F_N	0.00
Duty cycle	s3	

Sensor data	
Pulses	0
Output channels	0

Other data	
Gear ratio	62/1
Gear wheel material	plastic
Suppression components	
Enclosure class	IP 30
Weight [kg]	0.610

Remarks: d=selftapping screw M5

Characteristic curves

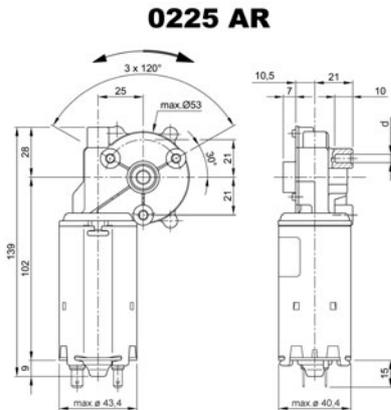

Motor picture

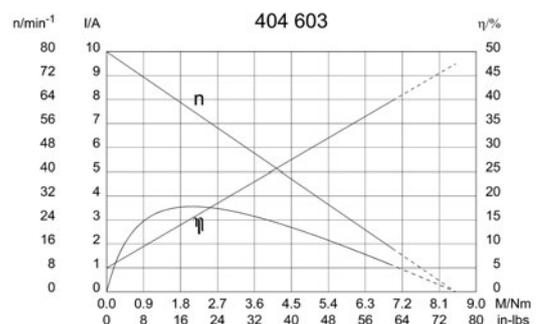

Output shaft drawing (W), Wiring diagrams (S) and Connector layout (K)

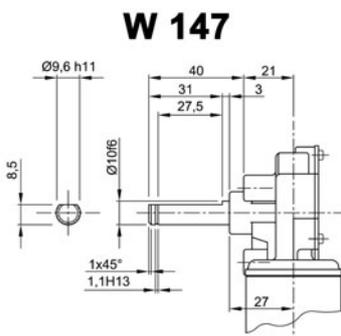

W 147

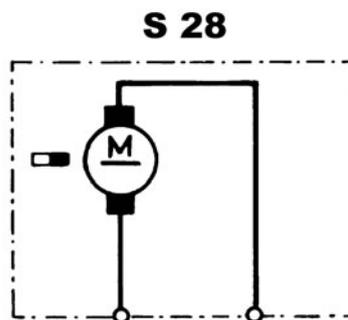

S 28

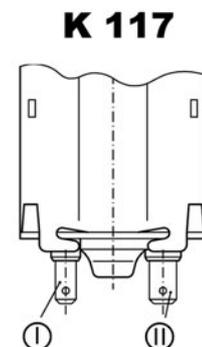

K 117

- I - Blade terminal ends 4,8 x 0,8 DIN 46 244
- II - Blade terminal ends 6,3 x 0,8 DIN 46 244

Design Data	
Commutation	Brushed
Direction of rotation	Bi-directional
Bearing type	A:Sleeve - B:Sleeve

Performance data		
Rated voltage [V]	U_N	24
Nominal torque [Nm]	M_N	0.50
No-load speed [min^{-1}]	n_0	540.0
Nominal power [W]	P_N	24.7
Nominal current [A]	I_N	2.0
Nominal force [kN]	F_N	0.00
Duty cycle	s3	

Sensor data	
Pulses	0
Output channels	0

Other data	
Gear ratio	56/4
Gear wheel material	plastic
Suppression components	7,5 μ H, 1nF
Enclosure class	IP 30
Weight [kg]	0.710

Remarks: d = for thread-forming screw M 5 DIN 7500

Characteristic curves

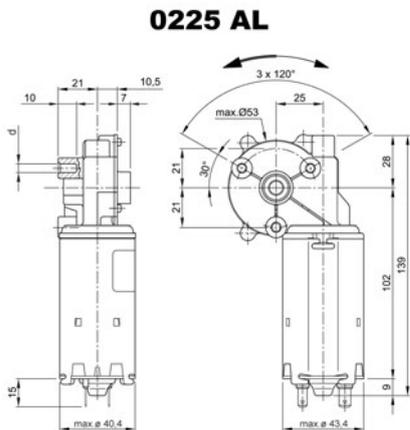

Motor picture

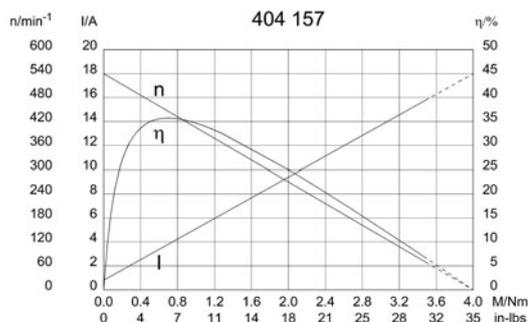

Output shaft drawing (W), Wiring diagrams (S) and Connector layout (K)

W 148

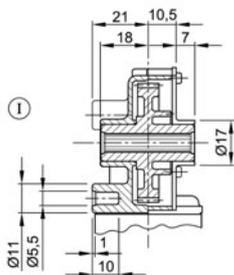

I Tapered splines 7 x 8 DIN 5481 continuous

S 74

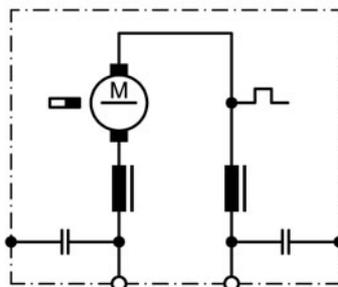

K 117

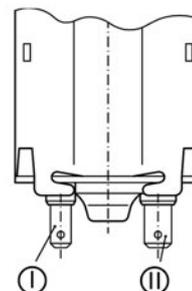

I Blade terminal ends 4,8 x 0,8 DIN 46 244
 II Blade terminal ends 6,3 x 0,8 DIN 46 244

Design Data	
Commutation	Brushed
Direction of rotation	Bi-directional
Bearing type	A:Sleeve - B:Sleeve

Performance data		
Rated voltage [V]	U_N	24
Nominal torque [Nm]	M_N	1.00
No-load speed [min^{-1}]	n_0	80.0
Nominal power [W]	P_N	7.39
Nominal current [A]	I_N	2.0
Nominal force [kN]	F_N	0.00
Duty cycle	s3	

Sensor data	
Pulses	0
Output channels	0

Other data	
Gear ratio	62/1
Gear wheel material	plastic
Suppression components	7,5 μ H, 1nF
Enclosure class	IP30
Weight [kg]	0.710

Remarks: d = for thread-forming screw M 5 DIN 7500

Characteristic curves

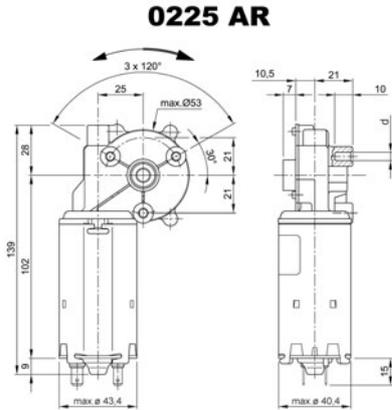

Motor picture

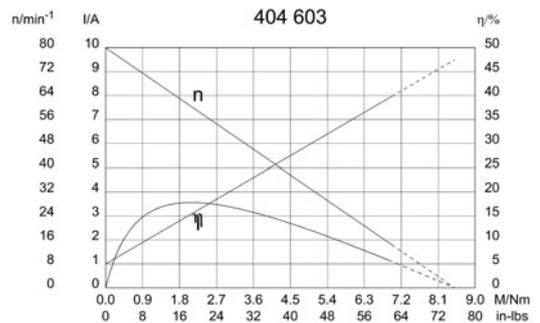

Output shaft drawing (W), Wiring diagrams (S) and Connector layout (K)

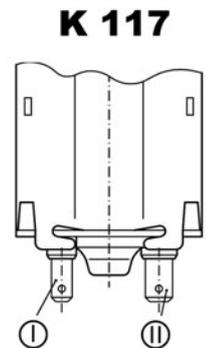
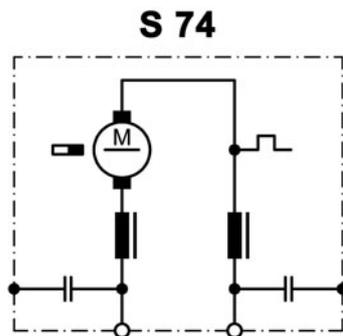
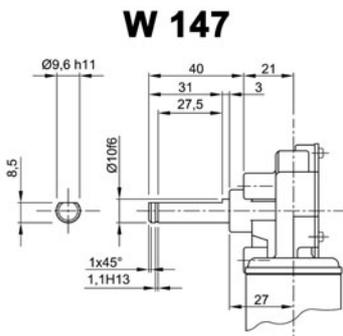

- I - Blade terminal ends 4,8 x 0,8 DIN 46 244
- II - Blade terminal ends 6,3 x 0,8 DIN 46 244

Design Data	
Commutation	Brushed
Direction of rotation	Bi-directional
Bearing type	A:Sleeve - B:Sleeve

Performance data		
Rated voltage [V]	U_N	24
Nominal torque [Nm]	M_N	1.00
No-load speed [min^{-1}]	n_0	28.0
Nominal power [W]	P_N	2.48
Nominal current [A]	I_N	1.0
Nominal force [kN]	F_N	0.00
Duty cycle	s2	

Sensor data	
Pulses	0
Output channels	0

Other data	
Gear ratio	72/1
Gear wheel material	plastic
Suppression components	7,5 μ H, 1nF
Enclosure class	IP 30
Weight [kg]	0.710

Remarks: d=selftapping screw M5

Characteristic curves

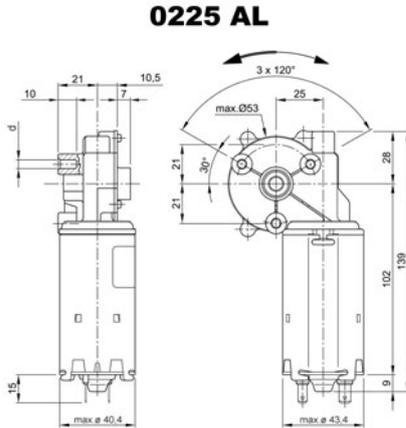

Motor picture

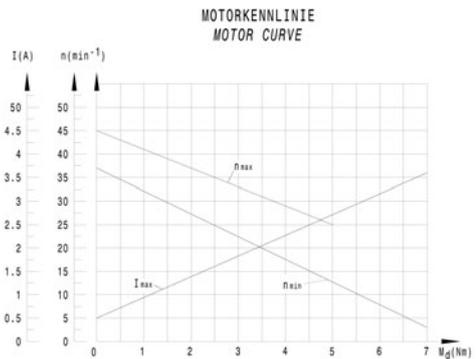

Output shaft drawing (W), Wiring diagrams (S) and Connector layout (K)

W 229

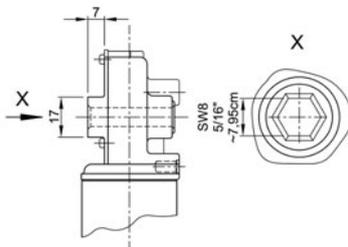

S 30

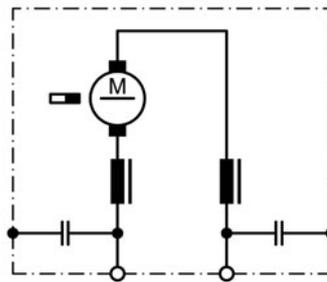

K 117

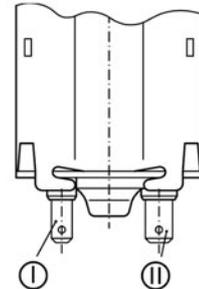

I - Blade terminal ends 4,8 x 0,8 DIN 46 244
 II - Blade terminal ends 6,3 x 0,8 DIN 46 244

Design Data	
Commutation	Brushed
Direction of rotation	Bi-directional
Bearing type	A:Sleeve - B:Sleeve

Performance data		
Rated voltage [V]	U_N	24
Nominal torque [Nm]	M_N	2.00
No-load speed [min^{-1}]	n_0	140.0
Nominal power [W]	P_N	25.1
Nominal current [A]	I_N	5.0
Nominal force [kN]	F_N	0.00
Duty cycle	s3	

Sensor data	
Pulses	62
Output channels	2

Other data	
Gear ratio	62/1
Gear wheel material	plastic
Suppression components	$4\mu\text{H}$, 1nF
Enclosure class	IP 30
Weight [kg]	0.710

Remarks: d = for thread-forming screw M5 DIN 7500

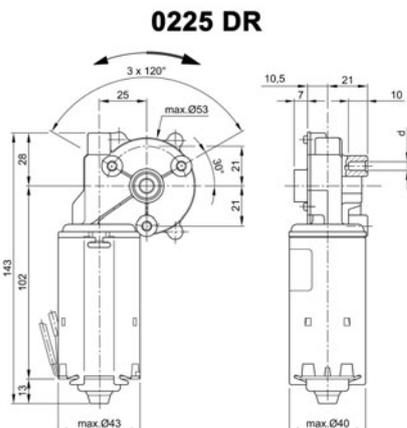

Motor picture

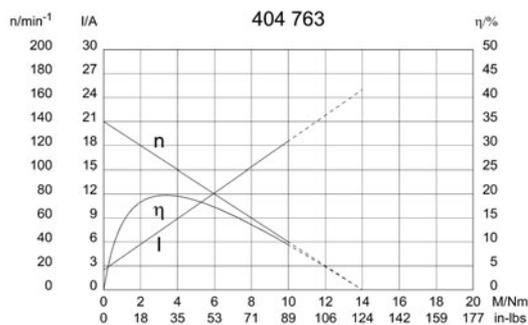

Output shaft drawing (W), Wiring diagrams (S) and Connector layout (K)

W 148

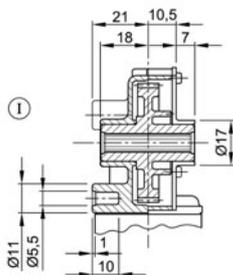

I Tapered splines 7 x 8 DIN 5481 continuous

S 30

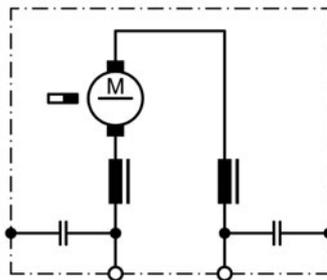

S 109

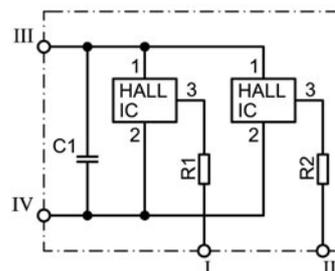

I Terminal 1, OUT A1, grey
 II Terminal 2, OUT A2, black
 III Terminal 3, +, white
 IV Terminal 4, -, red

Design Data	
Commutation	Brushed
Direction of rotation	Bi-directional
Bearing type	A:Sleeve - B:Sleeve

Performance data		
Rated voltage [V]	U_N	24
Nominal torque [Nm]	M_N	1.30
No-load speed [min^{-1}]	n_0	35.0
Nominal power [W]	P_N	3.94
Nominal current [A]	I_N	1.5
Nominal force [kN]	F_N	0.00
Duty cycle	s3	

Sensor data	
Pulses	0
Output channels	0

Other data	
Gear ratio	72/1
Gear wheel material	plastic
Suppression components	7,5 μ H, 1nF
Enclosure class	IP 30
Weight [kg]	0.570

Remarks: d = for self-tapping screw M5 DIN 7500

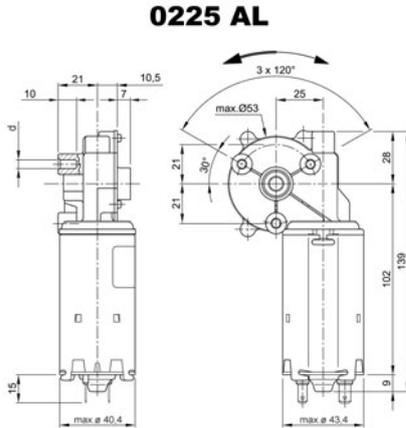

Motor picture

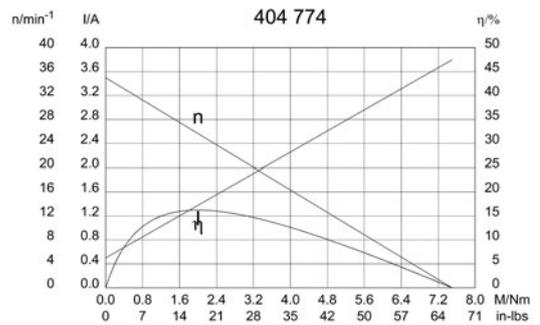

Output shaft drawing (W), Wiring diagrams (S) and Connector layout (K)

W 229

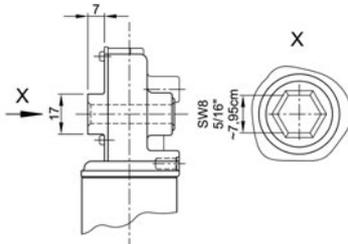

S 30

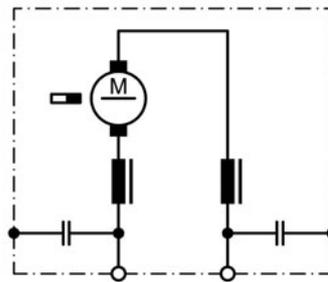

K 117

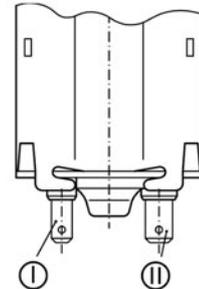

I - Blade terminal ends 4,8 x 0,8 DIN 46 244
 II - Blade terminal ends 6,3 x 0,8 DIN 46 244

Design Data	
Commutation	Brushed
Direction of rotation	Bi-directional
Bearing type	A:Sleeve - B:Sleeve

Performance data		
Rated voltage [V]	U_N	24
Nominal torque [Nm]	M_N	1.50
No-load speed [min^{-1}]	n_0	35.0
Nominal power [W]	P_N	4.47
Nominal current [A]	I_N	1.5
Nominal force [kN]	F_N	0.00
Duty cycle	s3	

Sensor data	
Pulses	288
Output channels	1

Other data	
Gear ratio	72/1
Gear wheel material	plastic
Suppression components	7,5 μ H
Enclosure class	IP 30
Weight [kg]	0.710

Remarks: d = for thread-forming screw M5 DIN 7500

Characteristic curves

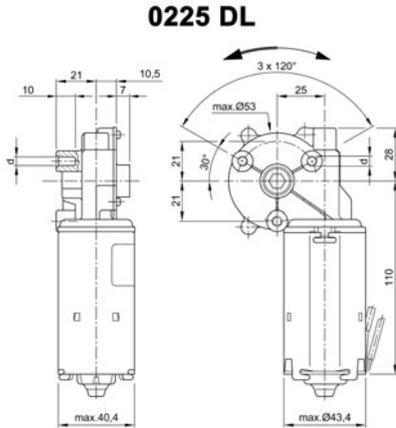

Motor picture

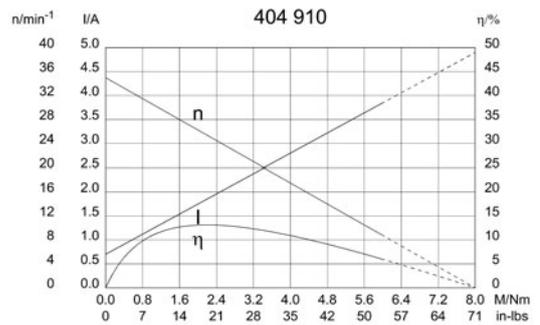

Output shaft drawing (W), Wiring diagrams (S) and Connector layout (K)

W 229

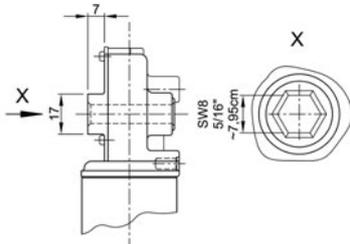

S 27

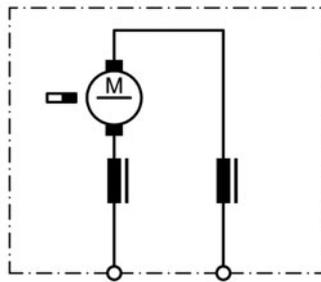

S 125

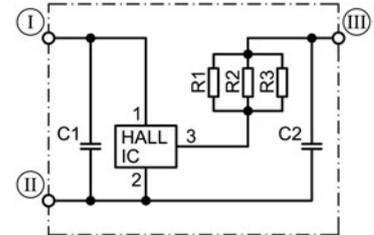

- I Terminal 3, +, white
- II Terminal 2, -, black
- III Terminal 6, OUT, red



NIDEC MOTORS & ACTUATORS ❖❖❖ MOTOR SERIES

0223 (SWMP)

❖❖❖ DC MOTORS WITH WORM GEAR



❖❖❖ TECHNICAL DESCRIPTION

Motorhousing:	sheet metal, rolled & corrosion protected
Excitation field:	permanent magnet
Type of gear mesh:	worm gear
Gear housing:	zinc die cast
Gear wheel material:	plastic or resinbonded fabric
Lubrication:	grease
Mechanical interface:	output shaft
Electric interface:	connector or leads with connector
Sensor:	optional
Thermal protection:	optional
EMC suppression:	optional

❖❖❖ APPLICATION

General machine construction, Automatic machines,
Agricultural technology, Business machines,
Laboratory appliances, Medical appliances,
Traffic & communications technology,
Photographic/optical equipment



Design Data	
Commutation	Brushed
Direction of rotation	Bi-directional
Bearing type	

Performance data		
Rated voltage [V]	U_N	24
Nominal torque [Nm]	M_N	2.00
No-load speed [min^{-1}]	n_0	50.0
Nominal power [W]	P_N	8.73
Nominal current [A]	I_N	1.5
Nominal force [kN]	F_N	0.00
Duty cycle		s1

Sensor data	
Pulses	0
Output channels	0

Other data	
Gear ratio	85/1
Gear wheel material	Resinbonded fabric
Suppression components	
Enclosure class	IP30
Weight [kg]	0.710

Remarks: d = M6

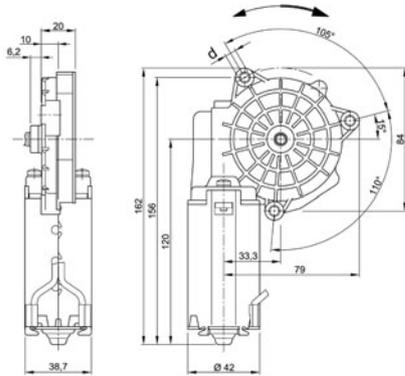

Motor picture



Characteristic curves

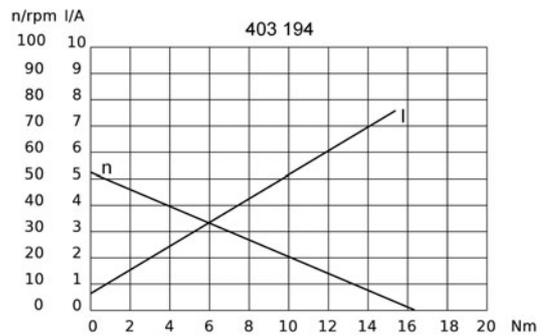

Output shaft drawing (W), Wiring diagrams (S) and Connector layout (K)

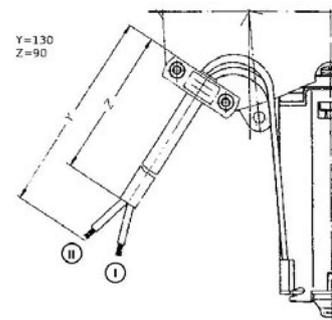
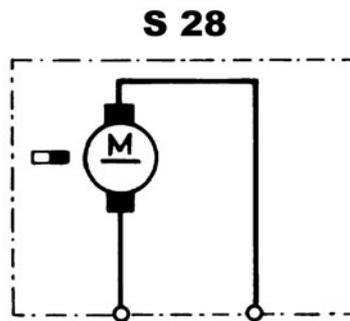
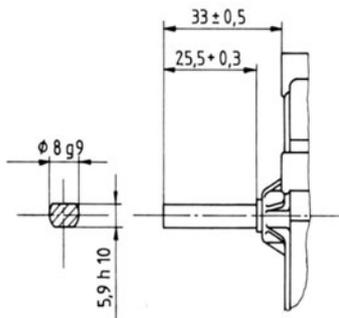

I: green
 II: black

Design Data	
Commutation	Brushed
Direction of rotation	Bi-directional
Bearing type	

Performance data		
Rated voltage [V]	U_N	24
Nominal torque [Nm]	M_N	2.00
No-load speed [min^{-1}]	n_0	54.0
Nominal power [W]	P_N	9.94
Nominal current [A]	I_N	1.5
Nominal force [kN]	F_N	0.00
Duty cycle		s1

Sensor data	
Pulses	0
Output channels	0

Other data	
Gear ratio	85/1
Gear wheel material	Plastic
Suppression components	7.5 μH , 47nF
Enclosure class	IP30
Weight [kg]	0.710

Remarks: d = 7.5mm, Ball bearing

Characteristic curves

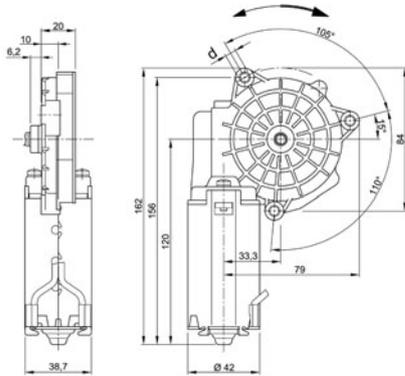

Motor picture

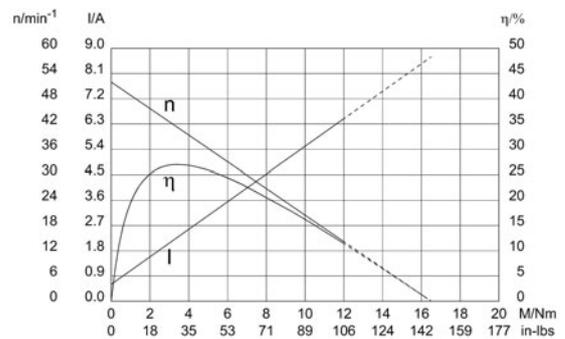

Output shaft drawing (W), Wiring diagrams (S) and Connector layout (K)

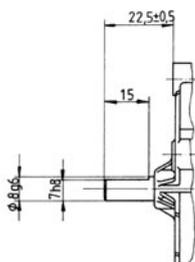

S 30

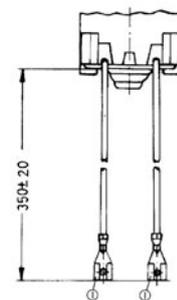
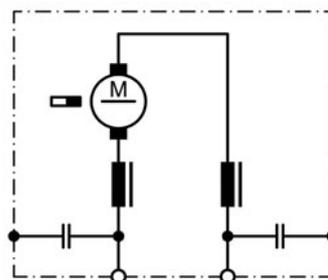

Spade connector 4.8 DIN 46 247

Design Data	
Commutation	Brushed
Direction of rotation	Bi-directional
Bearing type	

Performance data		
Rated voltage [V]	U_N	24
Nominal torque [Nm]	M_N	2.00
No-load speed [min^{-1}]	n_0	52.0
Nominal power [W]	P_N	9.57
Nominal current [A]	I_N	0.0
Nominal force [kN]	F_N	0.00
Duty cycle	s1	

Sensor data	
Pulses	0
Output channels	0

Other data	
Gear ratio	85/1
Gear wheel material	Plastic
Suppression components	
Enclosure class	IP30
Weight [kg]	0.710

Remarks: d = 7.5mm, Ball bearing

Characteristic curves

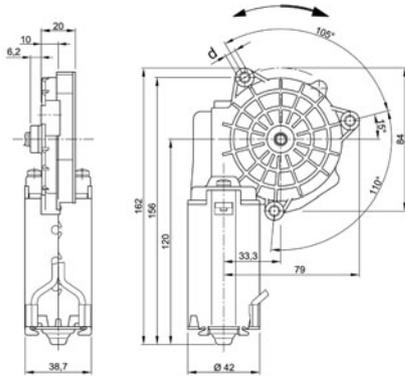

Motor picture

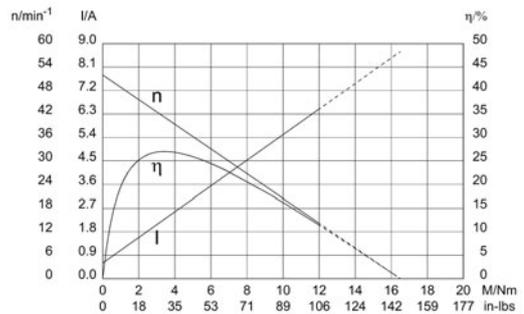

Output shaft drawing (W), Wiring diagrams (S) and Connector layout (K)

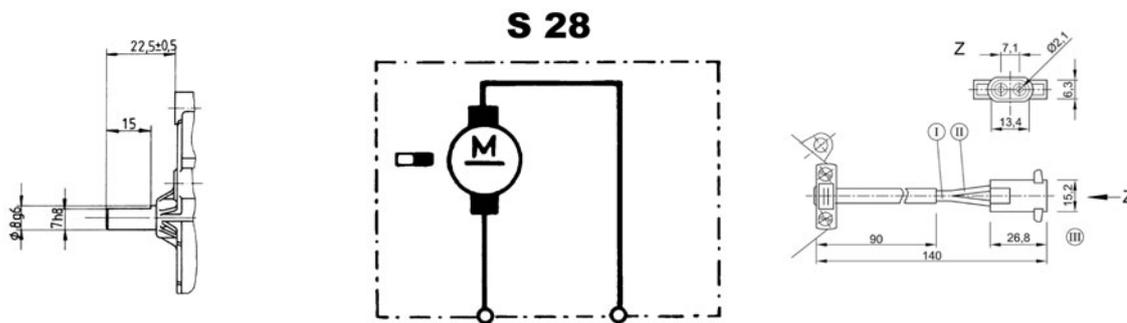

Design Data	
Commutation	Brushed
Direction of rotation	Bi-directional
Bearing type	

Performance data		
Rated voltage [V]	U_N	24
Nominal torque [Nm]	M_N	2.00
No-load speed [min^{-1}]	n_0	52.0
Nominal power [W]	P_N	9.34
Nominal current [A]	I_N	1.5
Nominal force [kN]	F_N	0.00
Duty cycle	s1	

Sensor data	
Pulses	0
Output channels	0

Other data	
Gear ratio	85/1
Gear wheel material	Plastic
Suppression components	
Enclosure class	IP30
Weight [kg]	0.710

Remarks: d = M6, Ball bearing

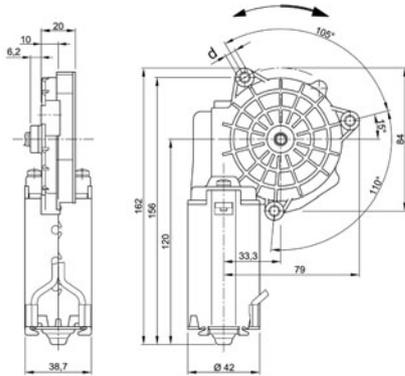

Motor picture



Characteristic curves

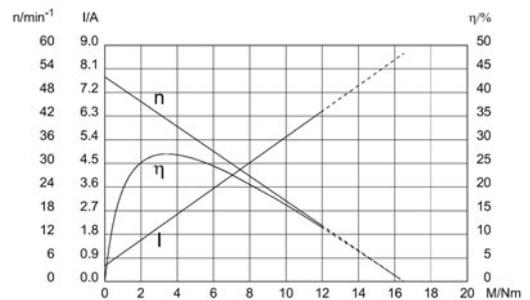

Output shaft drawing (W), Wiring diagrams (S) and Connector layout (K)

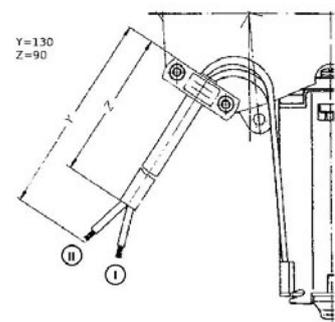
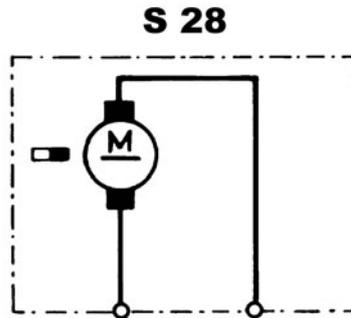
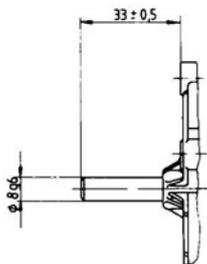

I: green
 II: black

Design Data

Commutation	Brushed
Direction of rotation	Bi-directional
Bearing type	

Performance data

Rated voltage [V]	U_N	24
Nominal torque [Nm]	M_N	2.00
No-load speed [min^{-1}]	n_0	52.0
Nominal power [W]	P_N	9.34
Nominal current [A]	I_N	1.5
Nominal force [kN]	F_N	0.00
Duty cycle		s1

Sensor data

Pulses	0
Output channels	0

Other data

Gear ratio	85/1
Gear wheel material	Plastic
Suppression components	
Enclosure class	IP30
Weight [kg]	0.710

Remarks: d = M6, Ball bearing

Characteristic curves

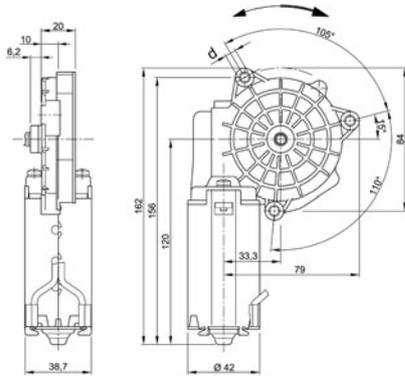

Motor picture

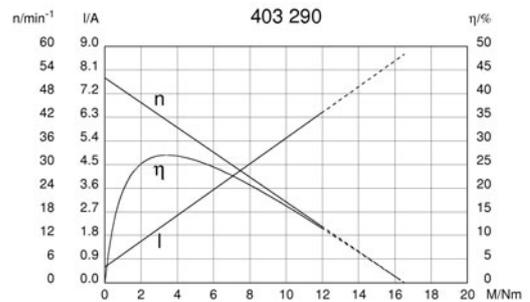

Output shaft drawing (W), Wiring diagrams (S) and Connector layout (K)

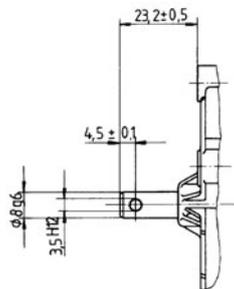

S 28

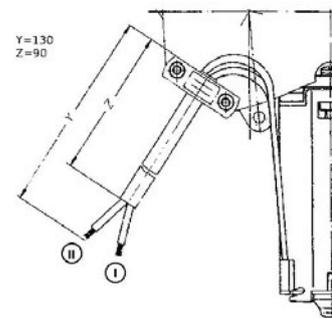
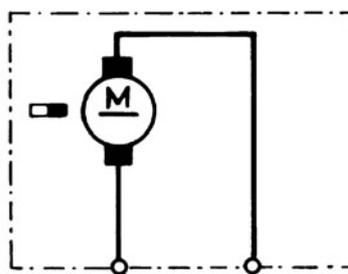

I: green
 II: black

Design Data	
Commutation	Brushed
Direction of rotation	Bi-directional
Bearing type	

Performance data		
Rated voltage [V]	U_N	24
Nominal torque [Nm]	M_N	1.30
No-load speed [min^{-1}]	n_0	110.0
Nominal power [W]	P_N	12.2
Nominal current [A]	I_N	2.6
Nominal force [kN]	F_N	0.00
Duty cycle		s1

Sensor data	
Pulses	0
Output channels	0

Other data	
Gear ratio	83/2
Gear wheel material	Plastic
Suppression components	
Enclosure class	IP30
Weight [kg]	0.710

Remarks: d = M6, Ball bearing

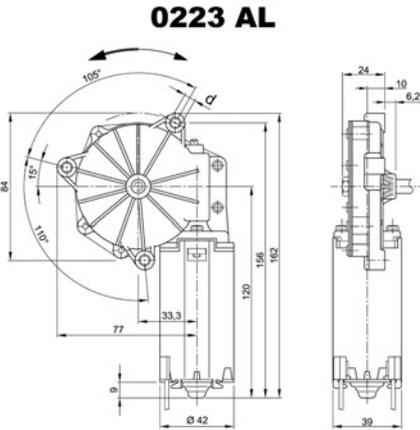

Motor picture

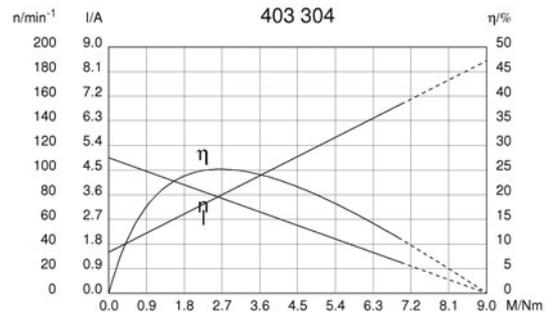

Output shaft drawing (W), Wiring diagrams (S) and Connector layout (K)

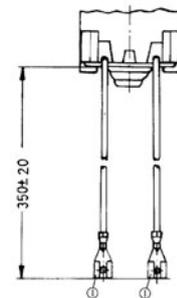
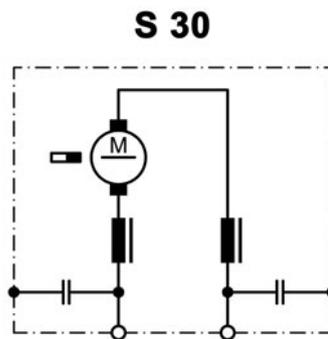
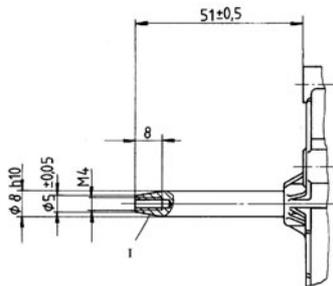

I: Cone 1:4

Spade connector 4.8 DIN 46 247

Design Data	
Commutation	Brushed
Direction of rotation	Bi-directional
Bearing type	

Performance data		
Rated voltage [V]	U_N	12
Nominal torque [Nm]	M_N	1.30
No-load speed [min^{-1}]	n_0	100.0
Nominal power [W]	P_N	11.1
Nominal current [A]	I_N	3.0
Nominal force [kN]	F_N	0.00
Duty cycle		s1

Sensor data	
Pulses	0
Output channels	0

Other data	
Gear ratio	83/2
Gear wheel material	Plastic
Suppression components	
Enclosure class	IP30
Weight [kg]	0.710

Remarks: d = M6, Ball bearing

Characteristic curves

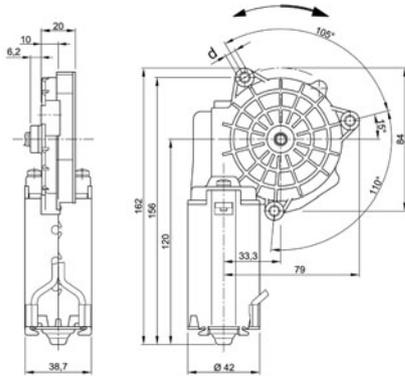

Motor picture

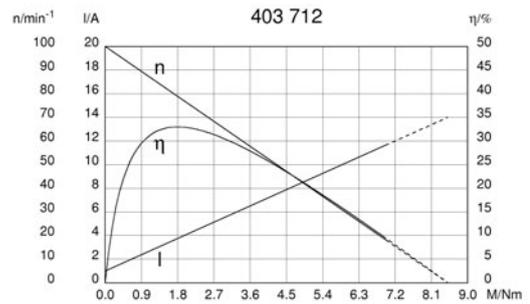

Output shaft drawing (W), Wiring diagrams (S) and Connector layout (K)

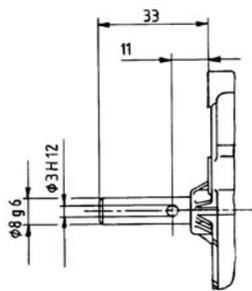

S 28

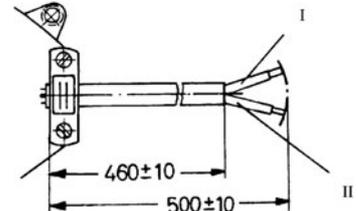
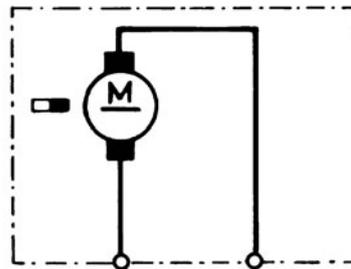

I: black
 II: green

Design Data	
Commutation	Brushed
Direction of rotation	Bi-directional
Bearing type	

Performance data		
Rated voltage [V]	U_N	24
Nominal torque [Nm]	M_N	2.00
No-load speed [min^{-1}]	n_0	50.0
Nominal power [W]	P_N	8.98
Nominal current [A]	I_N	2.5
Nominal force [kN]	F_N	0.00
Duty cycle	s1	

Sensor data	
Pulses	0
Output channels	0

Other data	
Gear ratio	99/1
Gear wheel material	Resinbonded fabric
Suppression components	
Enclosure class	
Weight [kg]	0.710

Remarks: d = M6, Ball bearing

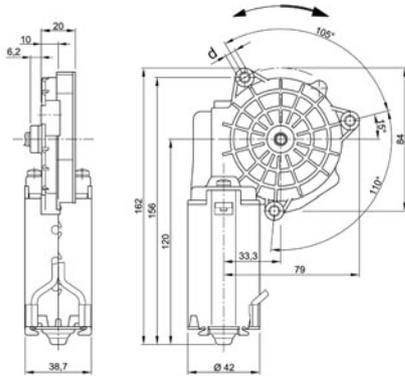

Motor picture



Characteristic curves

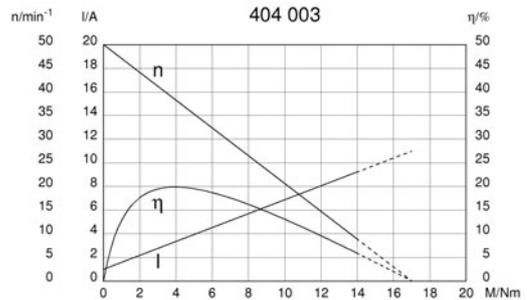

Output shaft drawing (W), Wiring diagrams (S) and Connector layout (K)

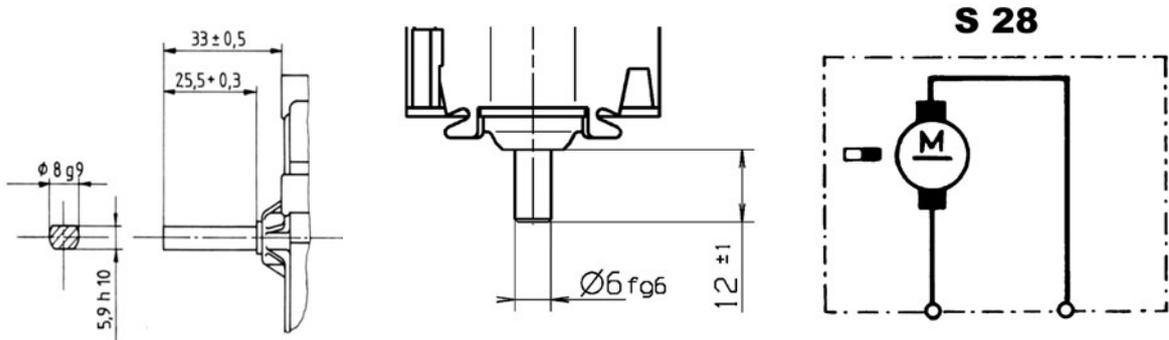

Design Data	
Commutation	Brushed
Direction of rotation	Bi-directional
Bearing type	

Performance data		
Rated voltage [V]	U_N	24
Nominal torque [Nm]	M_N	2.00
No-load speed [min^{-1}]	n_0	50.0
Nominal power [W]	P_N	8.38
Nominal current [A]	I_N	2.3
Nominal force [kN]	F_N	0.00
Duty cycle	s1	

Sensor data	
Pulses	0
Output channels	0

Other data	
Gear ratio	85/1
Gear wheel material	Resinbonded fabric
Suppression components	
Enclosure class	IP30
Weight [kg]	0.710

Remarks: d = M6, Ball bearing

Characteristic curves

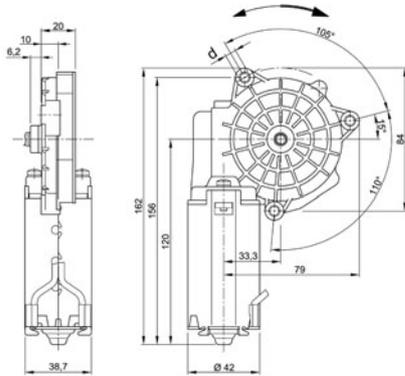

Motor picture

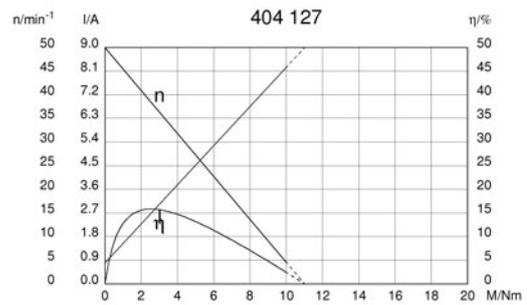

Output shaft drawing (W), Wiring diagrams (S) and Connector layout (K)

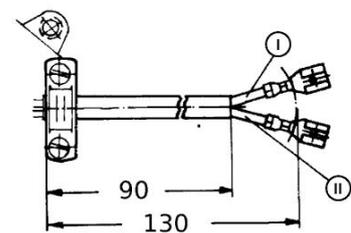
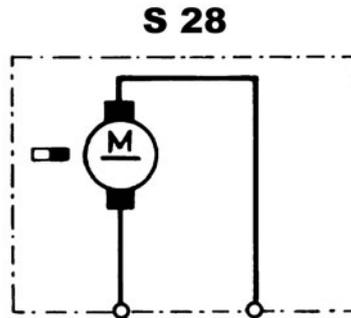
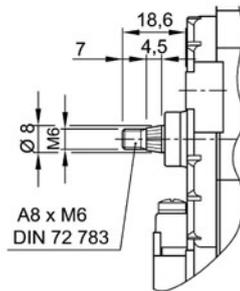

Spade connector 6.3 x 0.8 DIN 46 244
 I: black
 II: green



NIDEC MOTORS & ACTUATORS ⇄ MOTOR SERIES

0321 (GMPS)

⇄ DC MOTORS WITH WORM GEAR



⇄ TECHNICAL DESCRIPTION

Motorhousing:	sheet metal, rolled & corrosion protected
Excitation field:	permanent magnet
Type of gear mesh:	worm gear
Gear housing:	zinc die cast
Gear wheel material:	plastic
Lubrication:	grease
Mechanical interface:	steel lead screw
Electric interface:	connector
Sensor:	optional
Thermal protection:	optional
EMC suppression:	optional

⇄ INDUSTRIAL APPLICATION

Home automation

⇄ AUTOMOTIVE APPLICATION

Seat tilt and height adjustment

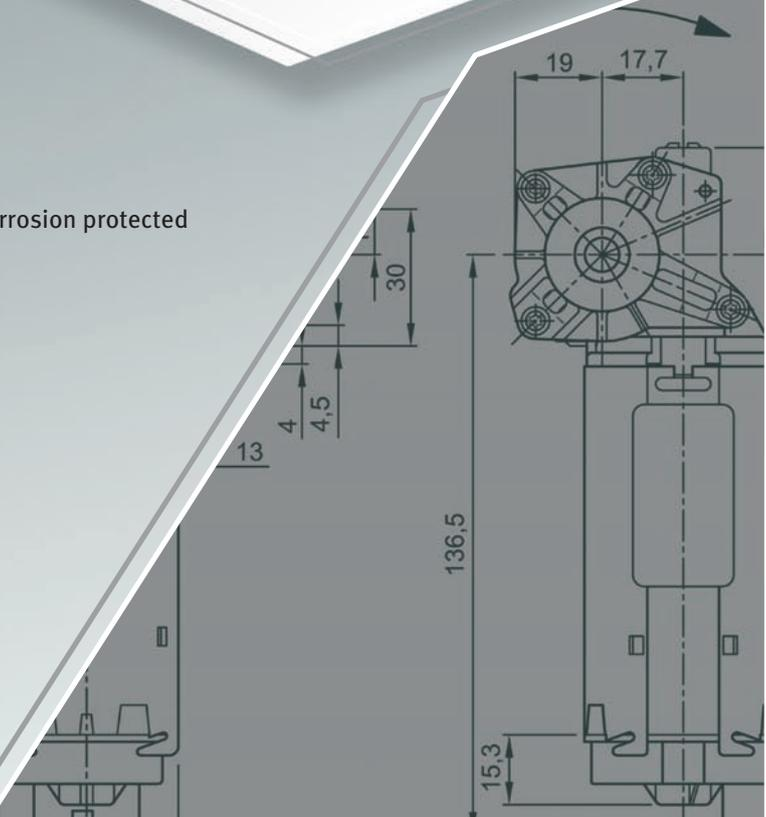

Design Data	
Commutation	Brushed
Direction of rotation	Bi-directional
Bearing type	A:Sleeve - B:Sleeve

Performance data		
Rated voltage [V]	U_N	12
Nominal torque [Nm]	M_N	1.50
No-load speed [min^{-1}]	n_0	180.0
Nominal power [W]	P_N	21.3
Nominal current [A]	I_N	9.0
Nominal force [kN]	F_N	2.00
Duty cycle	s3	

0321 BL

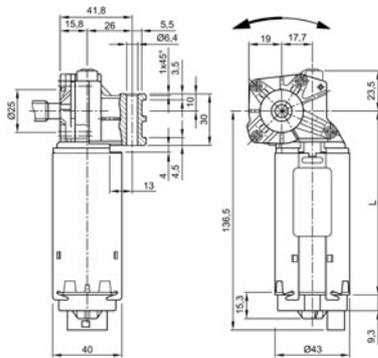

Sensor data	
Pulses	29
Output channels	1

Other data	
Gear ratio	29/1
Gear wheel material	plastic
Suppression components	5,5 μ H, 47nF, (0,47 μ F)
Enclosure class	IP 40
Weight [kg]	0.880

Remarks: L = 116mm, 1 start worm

Motor picture



Characteristic curves

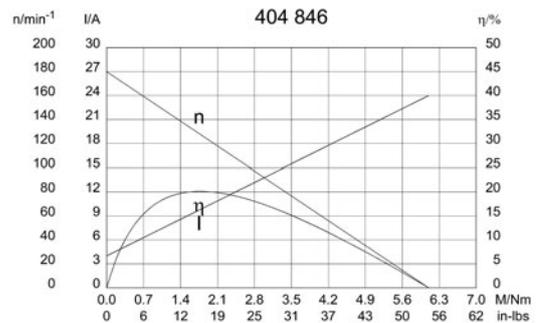

Output shaft drawing (W), Wiring diagrams (S) and Connector layout (K)

W 288

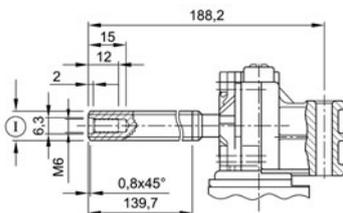

shape 7/16-8 STUB ACME RH, pressure angle 20°, pitch 3,175mm (0,125"), no of starts 1

S 93

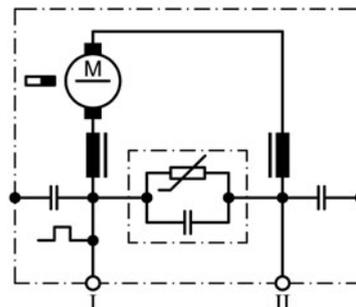

I Terminal 1
 II Terminal 5

S 85

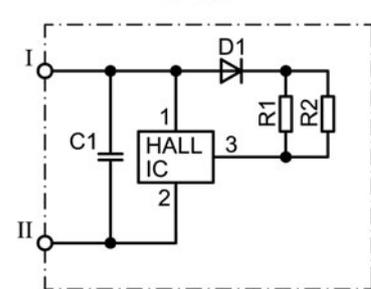

I Terminal 4, Hall-IC +
 II Terminal 2, Hall-IC -

Design Data	
Commutation	Brushed
Direction of rotation	Bi-directional
Bearing type	A:Sleeve - B:Sleeve

Performance data		
Rated voltage [V]	U_N	12
Nominal torque [Nm]	M_N	1.50
No-load speed [min^{-1}]	n_0	180.0
Nominal power [W]	P_N	21.3
Nominal current [A]	I_N	6.0
Nominal force [kN]	F_N	2.00
Duty cycle		s3

Sensor data	
Pulses	29
Output channels	1

Other data	
Gear ratio	29/1
Gear wheel material	plastic
Suppression components	5,5 μ H, 47nF, (0,47 μ F)
Enclosure class	IP 40
Weight [kg]	0.880

Remarks: L = 116mm, 1 start worm

Characteristic curves

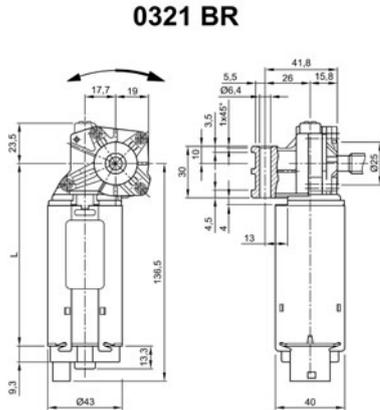

Motor picture

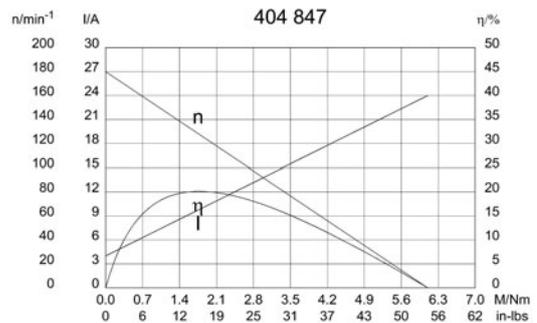

Output shaft drawing (W), Wiring diagrams (S) and Connector layout (K)

W 288

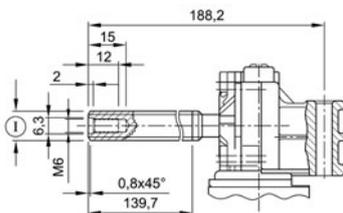

shape 7/16-8 STUB ACME RH, pressure angle 20°, pitch 3,175mm (0,125"), no of starts 1

S 93

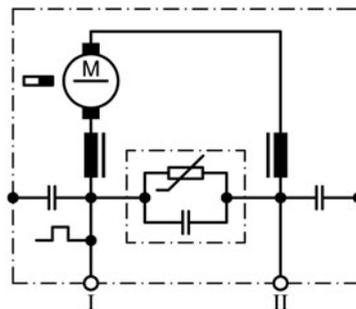

I Terminal 1
 II Terminal 5

S 85

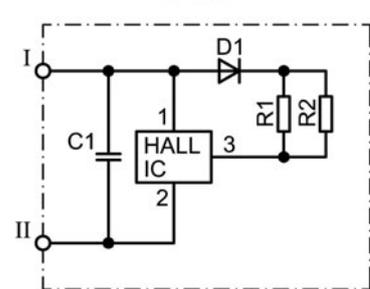

I Terminal 4, Hall-IC +
 II Terminal 2, Hall-IC -

Design Data	
Commutation	none
Direction of rotation	Bi-directional
Bearing type	A: Sleeve - B: Sleeve

Performance data		
Rated voltage [V]	U_N	12
Nominal torque [Nm]	M_N	1.50
No-load speed [min^{-1}]	n_0	145.0
Nominal power [W]	P_N	16.6
Nominal current [A]	I_N	6.0
Nominal force [kN]	F_N	1.50
Duty cycle	s3	

0321 BL

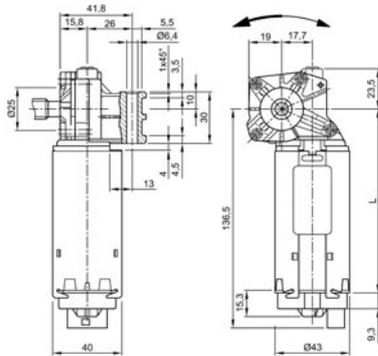

Sensor data	
Pulses	29
Output channels	1

Other data	
Gear ratio	29/1
Gear wheel material	
Suppression components	5,5 μ H, 47nF, (0,47 μ F)
Enclosure class	IP40
Weight [kg]	0.880

Remarks: 1 start worm

Motor picture



Characteristic curves

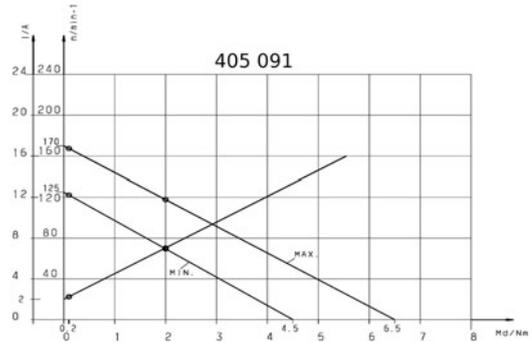

Output shaft drawing (W), Wiring diagrams (S) and Connector layout (K)

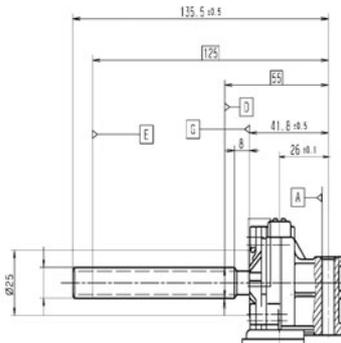

Output spindle: 7 / 16 Stub ACME RH

S 93

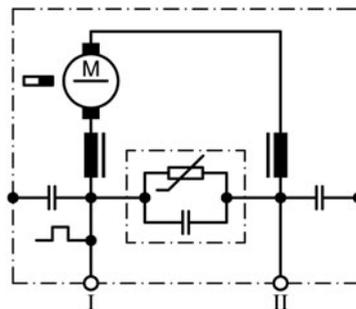

I Terminal 1
 II Terminal 5

S 85

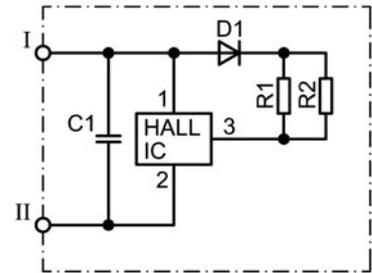

I Terminal 4, Hall-IC +
 II Terminal 2, Hall-IC -

Design Data	
Commutation	Brushed
Direction of rotation	Bi-directional
Bearing type	A: Sleeve - B: Sleeve

Performance data		
Rated voltage [V]	U_N	12
Nominal torque [Nm]	M_N	1.50
No-load speed [min^{-1}]	n_0	145.0
Nominal power [W]	P_N	16.6
Nominal current [A]	I_N	6.0
Nominal force [kN]	F_N	1.50
Duty cycle	s3	

Sensor data	
Pulses	0
Output channels	0

Other data	
Gear ratio	29/1
Gear wheel material	
Suppression components	5,5 μ H, 47nF, (0,47 μ F)
Enclosure class	IP40
Weight [kg]	0.880

Remarks: 1 start worm

0321 BL

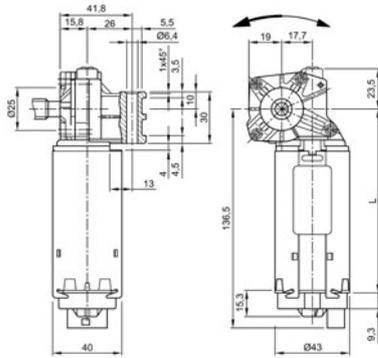

Motor picture



Characteristic curves

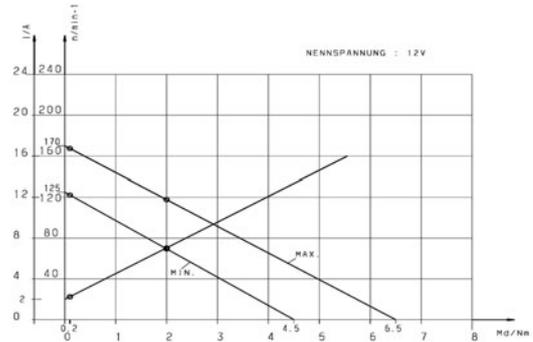

Output shaft drawing (W), Wiring diagrams (S) and Connector layout (K)

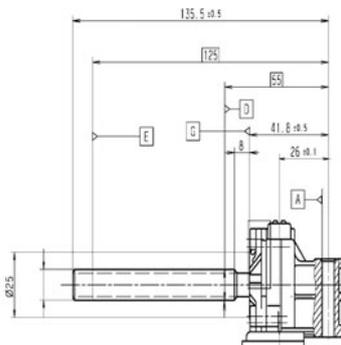

Output spindle: 7 / 16 Stub ACME RH

S 93

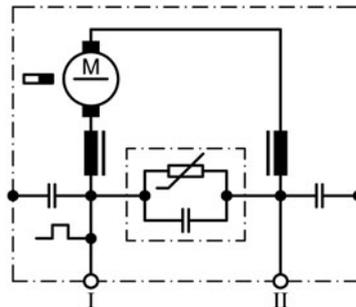

I Terminal 1
 II Terminal 5

K 220

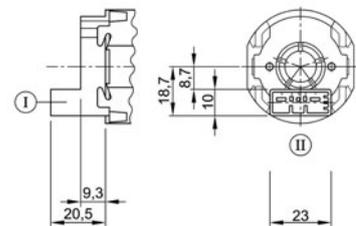

Connector TYCO C-208-15621 (Z) mating with:
Connector housing 1379217-3 & cover
 1379218-2
www.tycoelectronics.com

Design Data	
Commutation	Brushed
Direction of rotation	Bi-directional
Bearing type	A: Sleeve - B: Sleeve

Performance data		
Rated voltage [V]	U_N	24
Nominal torque [Nm]	M_N	1.50
No-load speed [min^{-1}]	n_0	145.0
Nominal power [W]	P_N	17.2
Nominal current [A]	I_N	4.5
Nominal force [kN]	F_N	1.50
Duty cycle	s3	

0321 BL

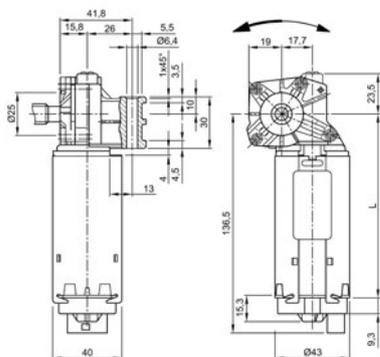

Sensor data	
Pulses	0
Output channels	0

Other data	
Gear ratio	29/1
Gear wheel material	
Suppression components	
Enclosure class	IP40
Weight [kg]	0.880

Remarks: L = 116mm

Motor picture



Characteristic curves

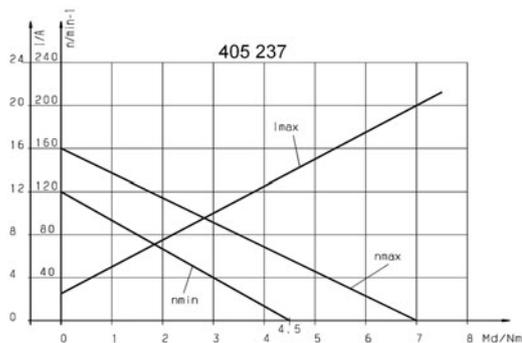

Output shaft drawing (W), Wiring diagrams (S) and Connector layout (K)

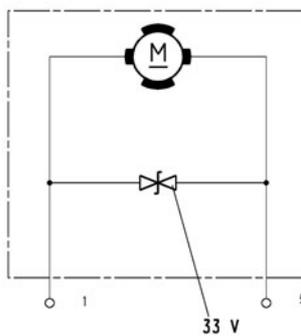
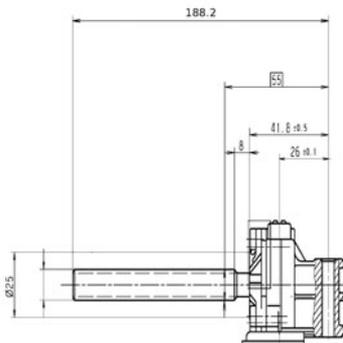

K 220

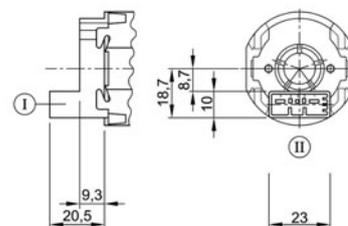

Output spindle: 7 / 16 Stub ACME RH

Connector TYCO C-208-15621 (Z) mating with:
 Connector housing 1379217-3 & cover
 1379218-2
www.tycoelectronics.com



NIDEC MOTORS & ACTUATORS ❖❖❖ MOTOR SERIES

0266 (DCK31)

❖❖❖ DC MOTORS WITH WORM GEAR

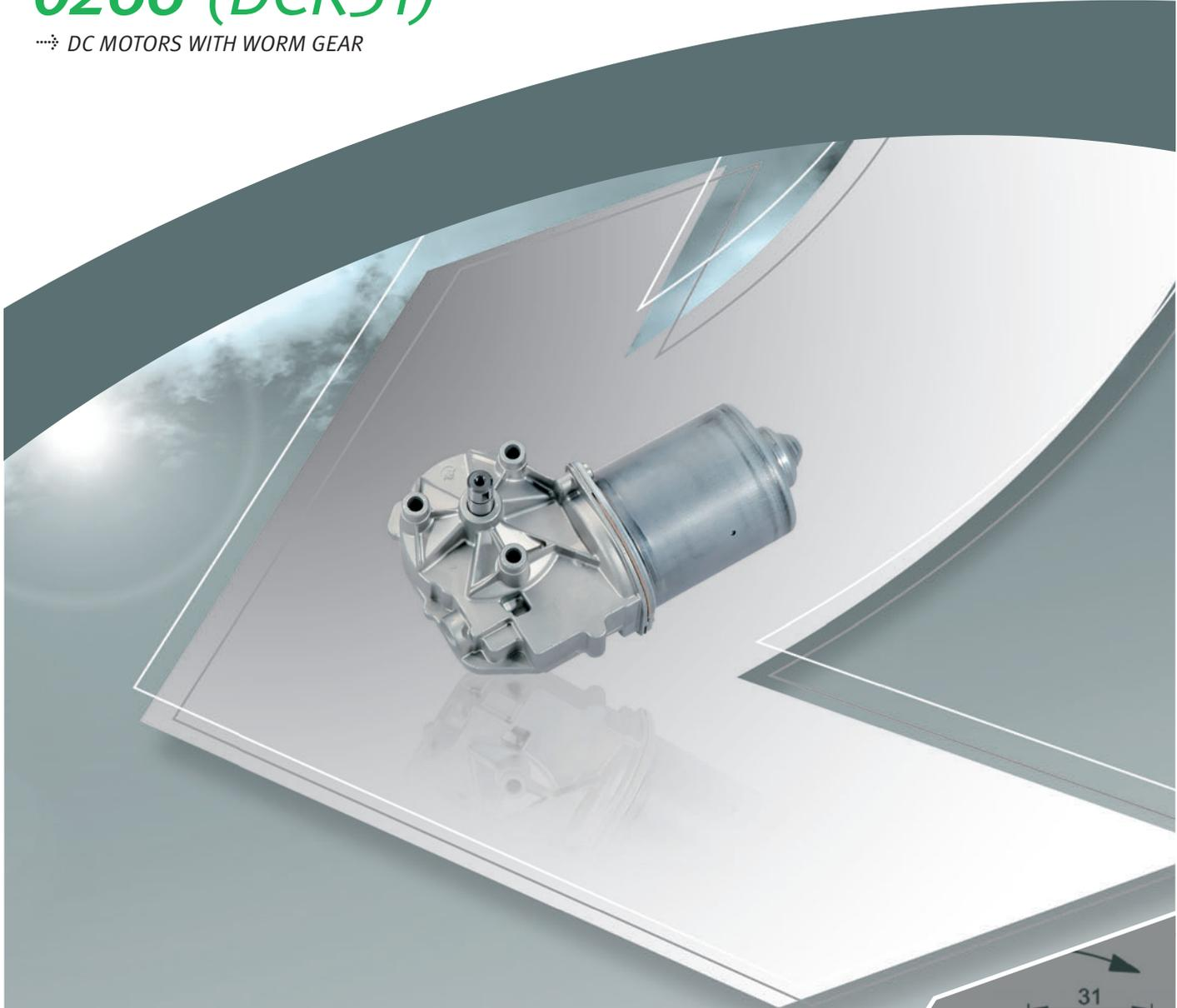

❖❖❖ TECHNICAL DESCRIPTION

Motorhousing:	deep drawn & corrosion protected
Excitation field:	permanent magnet
Type of gear mesh:	worm gear
Gear housing:	zinc die cast
Gear wheel material:	plastic, steel
Lubrication:	grease
Mechanical interface:	steel shaft
Electric interface:	connector or leads with connector
Sensor:	optional
Thermal protection:	optional
EMC suppression:	optional

❖❖❖ INDUSTRIAL APPLICATION

Door & gate openers, pumps, lubricating technology, appliance, linear actuators

❖❖❖ AUTOMOTIVE APPLICATION

Trunk & tailgate opening & closing

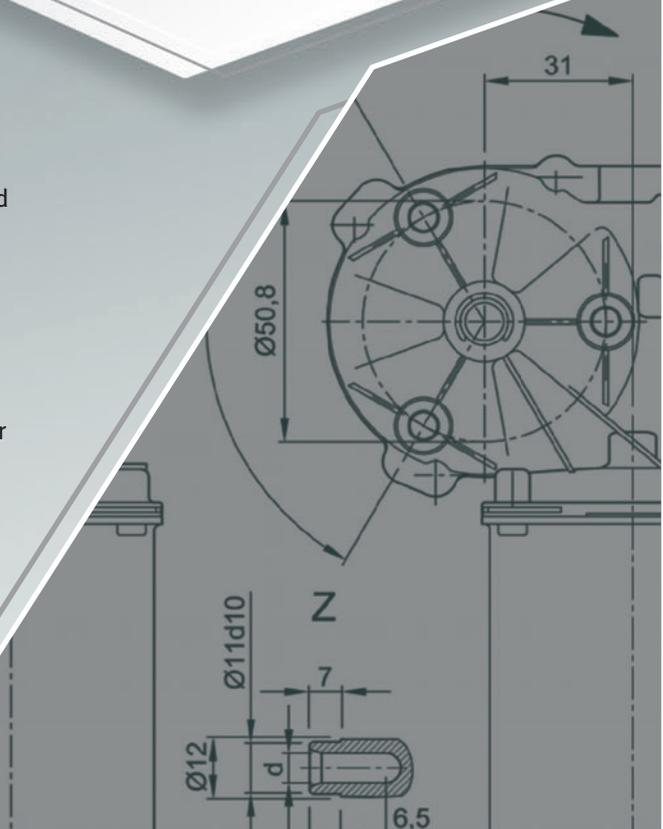

Design Data	
Commutation	Brushed
Direction of rotation	Bi-directional
Bearing type	A:ball - B:sleeve

Performance data		
Rated voltage [V]	U_N	24
Nominal torque [Nm]	M_N	4.00
No-load speed [min^{-1}]	n_0	65.0
Nominal power [W]	P_N	25.0
Nominal current [A]	I_N	4.0
Nominal force [kN]	F_N	0.00
Duty cycle	s1	

Sensor data	
Pulses	69
Output channels	1

Other data	
Gear ratio	69/1
Gear wheel material	plastic
Suppression components	6 μH
Enclosure class	IP 30
Weight [kg]	1.250

Remarks: d=for selftapping screw M6 DIN ISO 965-2

Characteristic curves

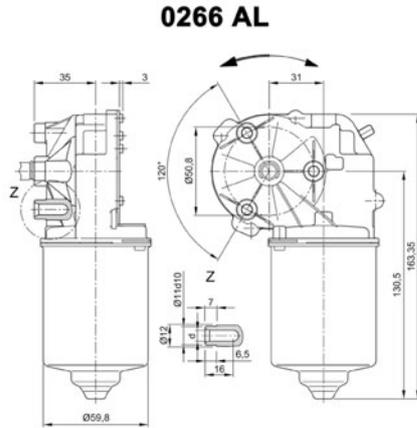

Motor picture

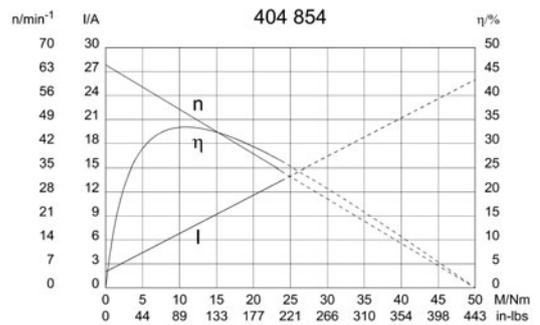

Output shaft drawing (W), Wiring diagrams (S) and Connector layout (K)

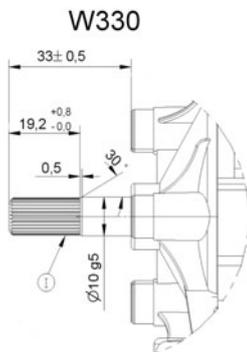

S 27

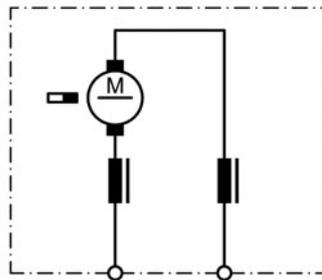

S150

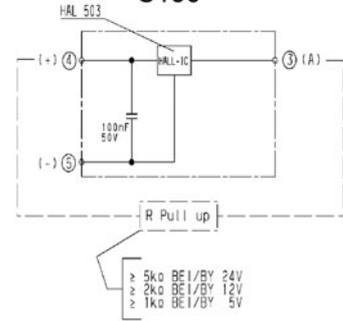

I serration (rolled): no of teeth 28, pitch circle dia 9 mm, tip circle dia 9.6 mm, root circle dia 8.26 mm space width angle 60° - go/no go gauge Frenco 33906 - www.frenco.de

Design Data

Commutation	Brushed
Direction of rotation	Bi-directional
Bearing type	A: ball - B:sleeve

Performance data

Rated voltage [V]	U_N	24
Nominal torque [Nm]	M_N	4.00
No-load speed [min^{-1}]	n_0	66.0
Nominal power [W]	P_N	25.4
Nominal current [A]	I_N	4.0
Nominal force [kN]	F_N	0.00
Duty cycle		s1

Sensor data

Pulses	0
Output channels	0

Other data

Gear ratio	69/1
Gear wheel material	plastic
Suppression components	3,5 μ H, 1 μ F
Enclosure class	IP 30
Weight [kg]	1.210

Remarks: d = for thread-forming screw M6 DIN ISO 965-2

Characteristic curves

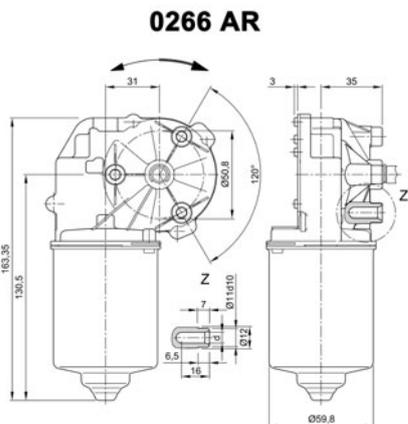

Motor picture

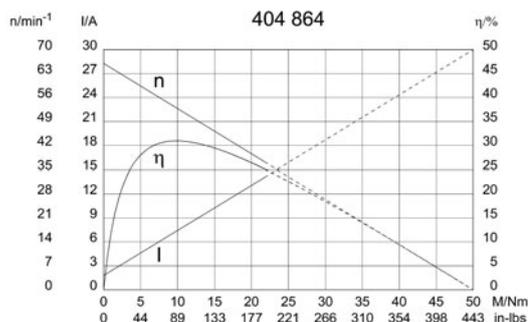

Output shaft drawing (W), Wiring diagrams (S) and Connector layout (K)

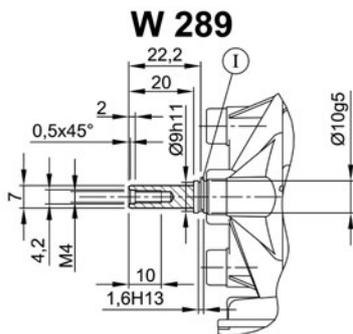

S 30

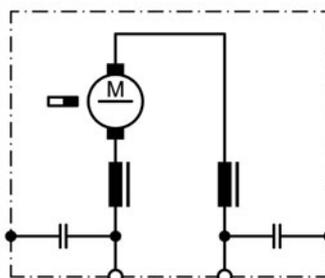

K 320

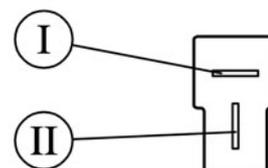

I Circlip

Flat plug (DIN 46244) 6,3x0,8 mating with receptacle housing part#180907, drwg# C-180907& Receptacles for tabs, conductor cross section 0,5-1,5 sqmm (20-18AWG) part# 925603-x, drwg# 925603 www.tycoelectronics.com

Design Data	
Commutation	Brushed
Direction of rotation	Bi-directional
Bearing type	A: Ball - B: Sleeve

Performance data		
Rated voltage [V]	U_N	24
Nominal torque [Nm]	M_N	4.00
No-load speed [min^{-1}]	n_0	75.0
Nominal power [W]	P_N	28.9
Nominal current [A]	I_N	5.5
Nominal force [kN]	F_N	0.00
Duty cycle	s1	

Sensor data	
Pulses	69
Output channels	2

Other data	
Gear ratio	69/1
Gear wheel material	Plastic
Suppression components	6.0 μ H, 1nF
Enclosure class	IP30
Weight [kg]	1.210

Remarks: d = for thread-forming screw M6 DIN ISO 965-2

Characteristic curves

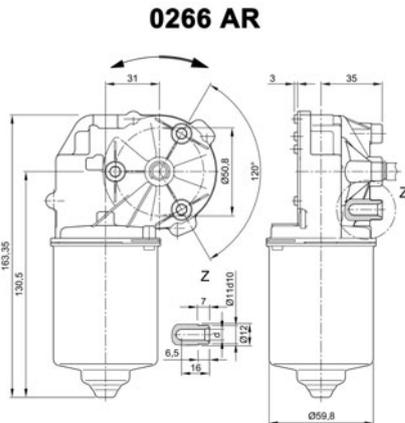

Motor picture

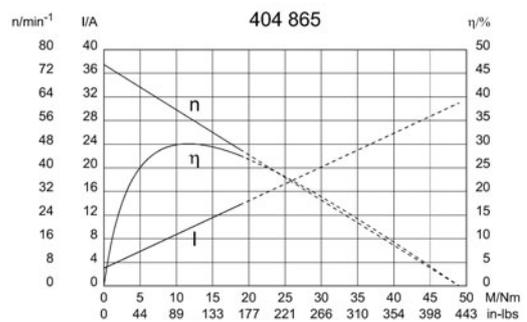

Output shaft drawing (W), Wiring diagrams (S) and Connector layout (K)

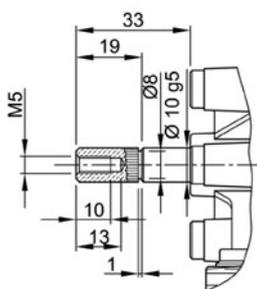

S 30

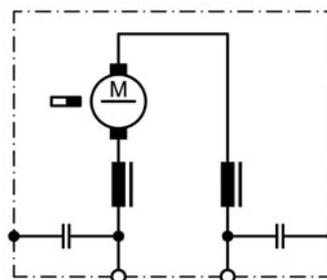

S 141

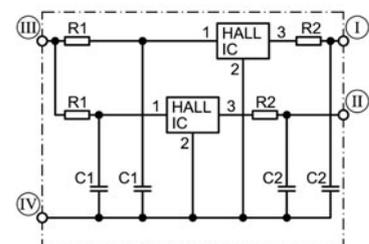

- I Hall-IC A1, terminal 3
- II Hall-IC A2, terminal 4
- III Hall-IC +, terminal 5
- IV Hall-IC -, terminal 6

Design Data

Commutation	Brushed
Direction of rotation	Bi-directional
Bearing type	A:ball - B:sleeve

Performance data

Rated voltage [V]	U_N	24
Nominal torque [Nm]	M_N	4.00
No-load speed [min^{-1}]	n_0	64.0
Nominal power [W]	P_N	24.4
Nominal current [A]	I_N	4.0
Nominal force [kN]	F_N	0.00
Duty cycle		s1

Sensor data

Pulses	0
Output channels	0

Other data

Gear ratio	69/1
Gear wheel material	plastic
Suppression components	6 μ H, 1nF
Enclosure class	IP 30
Weight [kg]	1.216

Remarks: d = for thread-forming screw M6 DIN ISO 965-2

Characteristic curves

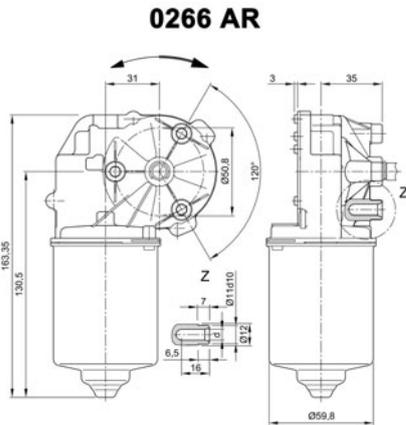

Motor picture

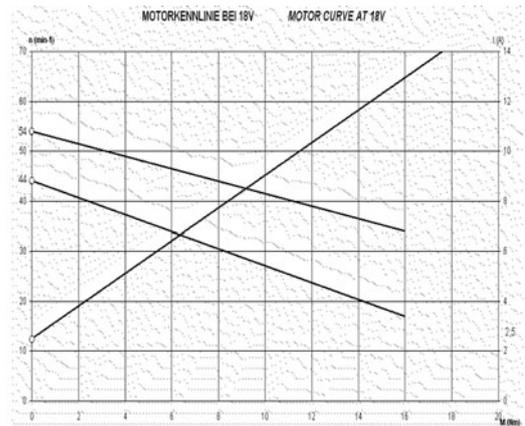

Output shaft drawing (W), Wiring diagrams (S) and Connector layout (K)

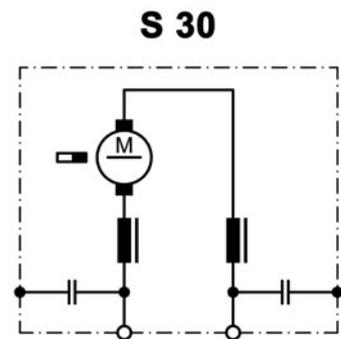
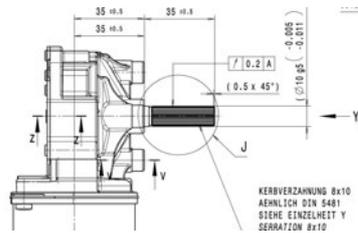
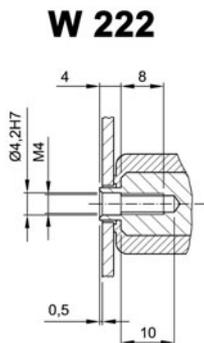

! Only for connection of encoder

Design Data	
Commutation	Brushed
Direction of rotation	Bi-directional
Bearing type	A: ball - B: sleeve

Performance data		
Rated voltage [V]	U_N	24
Nominal torque [Nm]	M_N	6.00
No-load speed [min^{-1}]	n_0	35.0
Nominal power [W]	P_N	19.2
Nominal current [A]	I_N	3.0
Nominal force [kN]	F_N	0.00
Duty cycle	s1	

Sensor data	
Pulses	0
Output channels	0

Other data	
Gear ratio	69/1
Gear wheel material	plastic
Suppression components	$6\mu\text{H}$, 1nF
Enclosure class	IP 30
Weight [kg]	1.210

Remarks: d = for thread-forming screw M6 DIN ISO 965-2

Characteristic curves

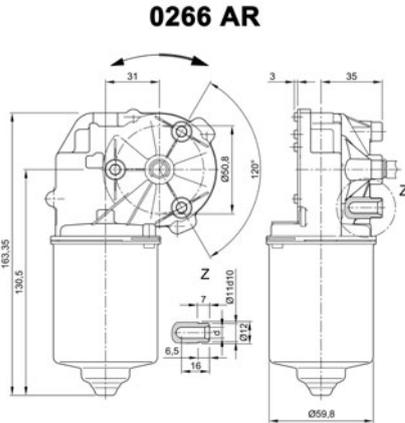

Motor picture

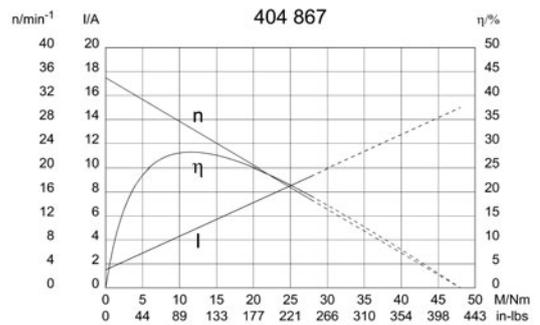

Output shaft drawing (W), Wiring diagrams (S) and Connector layout (K)

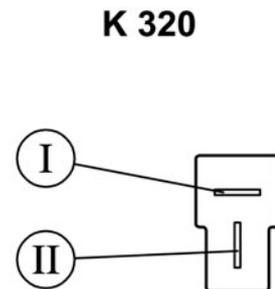
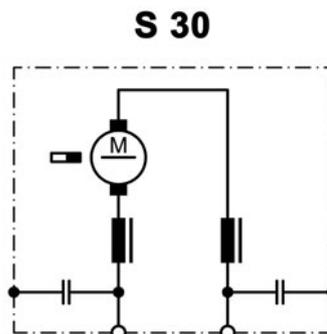
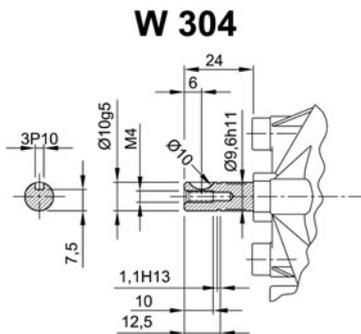

Flat plug (DIN 46244) 6,3x0,8 mating with receptacle housing part#180907, drwg# C-180907& Receptacles for tabs, conductor cross section 0,5-1,5 sqmm (20-18AWG) part# 925603-x, drwg# 925603 www.tycoelectronics.com

Design Data	
Commutation	Brushed
Direction of rotation	Bi-directional
Bearing type	A:Ball - B:Sleeve

Performance data		
Rated voltage [V]	U_N	12
Nominal torque [Nm]	M_N	4.00
No-load speed [min^{-1}]	n_0	30.0
Nominal power [W]	P_N	10.8
Nominal current [A]	I_N	3.0
Nominal force [kN]	F_N	0.00
Duty cycle	s1	

Sensor data	
Pulses	0
Output channels	0

Other data	
Gear ratio	69/1
Gear wheel material	plastic
Suppression components	6 μ H
Enclosure class	IP 30
Weight [kg]	1.210

Remarks: d = for thread-forming screw M6 DIN ISO 965-2

Characteristic curves

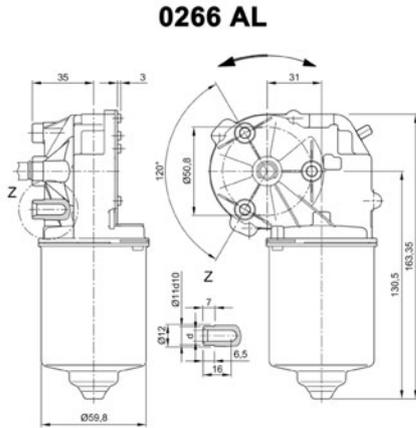

Motor picture

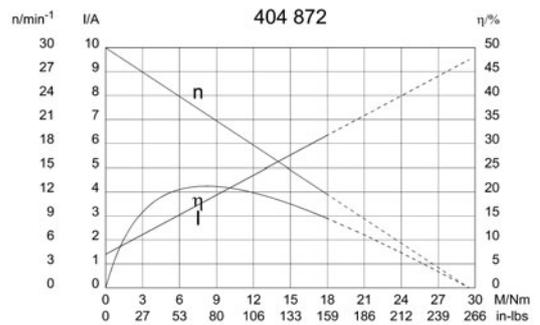

Output shaft drawing (W), Wiring diagrams (S) and Connector layout (K)

W 252

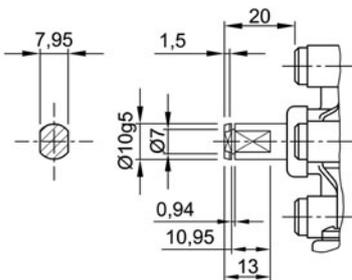

S 25

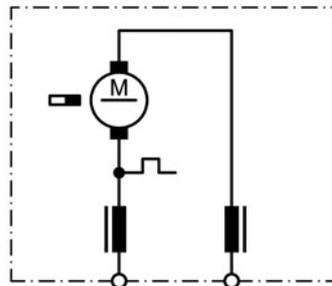

K 320

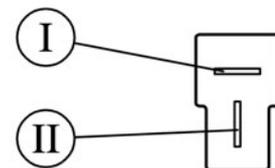

Flat plug (DIN 46244) 6,3x0,8 mating with receptacle housing part#180907, drwg# C-180907& Receptacles for tabs, conductor cross section 0,5-1,5 sqmm (20-18AWG) part# 925603-x, drwg# 925603 www.tycoelectronics.com

Design Data	
Commutation	Brushed
Direction of rotation	Bi-directional
Bearing type	A:Ball - B:Sleeve

Performance data		
Rated voltage [V]	U_N	24
Nominal torque [Nm]	M_N	2.00
No-load speed [min^{-1}]	n_0	160.0
Nominal power [W]	P_N	30.9
Nominal current [A]	I_N	4.0
Nominal force [kN]	F_N	0.00
Duty cycle	s1	

Sensor data	
Pulses	1
Output channels	2

Other data	
Gear ratio	53/2
Gear wheel material	plastic
Suppression components	6 μ H, 1nF
Enclosure class	IP 30
Weight [kg]	1.210

Remarks: d= for thread forming screw M6 DIN ISO 965-2

Characteristic curves

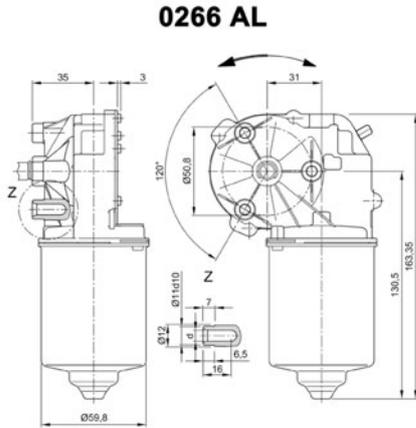

Motor picture

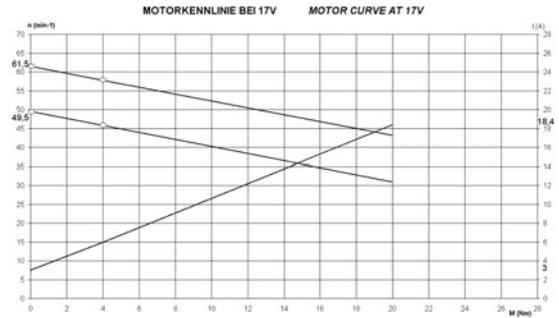

Output shaft drawing (W), Wiring diagrams (S) and Connector layout (K)

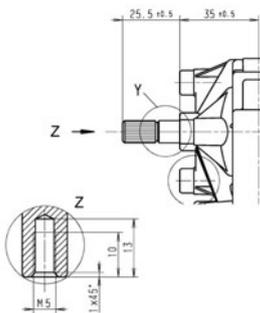

S 30

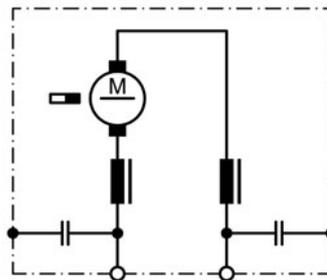

K 320

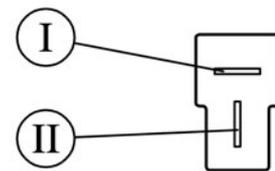

I serration (rolled): **No teeth 28, pitch circle dia 9 mm, tip circle dia 9.6 mm, root circle dia 8.26 mm space width angle 60° - go/no go gauge** Frenco 33906 - www.frenco.de

Flat plug (DIN 46244) 6,3x0,8 mating with receptacle housing part#180907, drwg# C-180907& Receptacles for tabs, conductor cross section 0,5-1,5 sqmm (20-18AWG) part# 925603-x, drwg# 925603 www.tycoelectronics.com

Design Data

Commutation	Brushed
Direction of rotation	Bi-directional
Bearing type	A: Ball - B:Sleeve

Performance data

Rated voltage [V]	U_N	24
Nominal torque [Nm]	M_N	3.00
No-load speed [min^{-1}]	n_0	14.0
Nominal power [W]	P_N	3.60
Nominal current [A]	I_N	1.0
Nominal force [kN]	F_N	0.00
Duty cycle		s1

Sensor data

Pulses	234
Output channels	1

Other data

Gear ratio	78/1
Gear wheel material	bronze
Suppression components	$6\mu\text{H}, 1\text{nF}$
Enclosure class	IP 30
Weight [kg]	1.210

Remarks: d = for thread-forming screw M6 DIN ISO 965-2

Characteristic curves

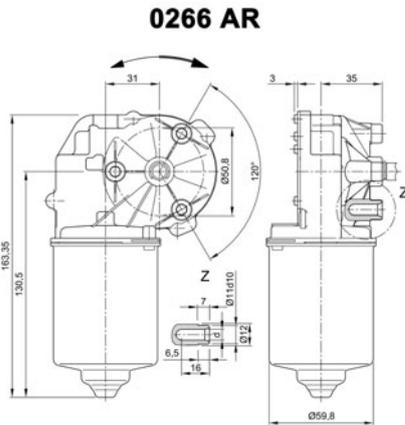

Motor picture

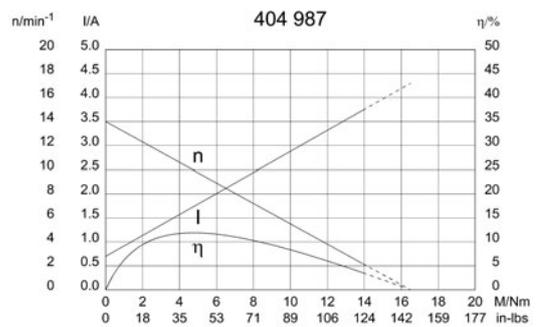

Output shaft drawing (W), Wiring diagrams (S) and Connector layout (K)

W 327

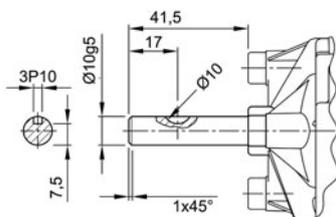

S 27

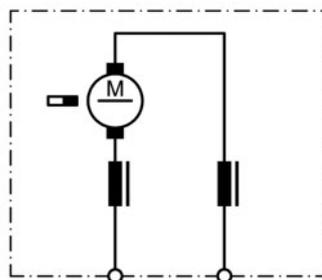

S150

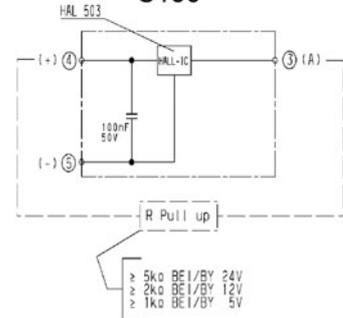

Design Data	
Commutation	Brushed
Direction of rotation	Bi-directional
Bearing type	A: ball - B: sleeve

Performance data		
Rated voltage [V]	U_N	24
Nominal torque [Nm]	M_N	4.00
No-load speed [min^{-1}]	n_0	36.0
Nominal power [W]	P_N	12.9
Nominal current [A]	I_N	3.0
Nominal force [kN]	F_N	0.00
Duty cycle	s1	

Sensor data	
Pulses	207
Output channels	1

Other data	
Gear ratio	69/1
Gear wheel material	plastic
Suppression components	$6\mu\text{H}$, 1nF
Enclosure class	IP 30
Weight [kg]	1.210

Remarks: d = for thread-forming screw M6 DIN ISO 965-2

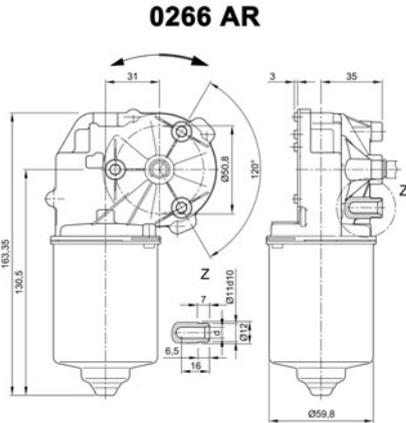

Motor picture

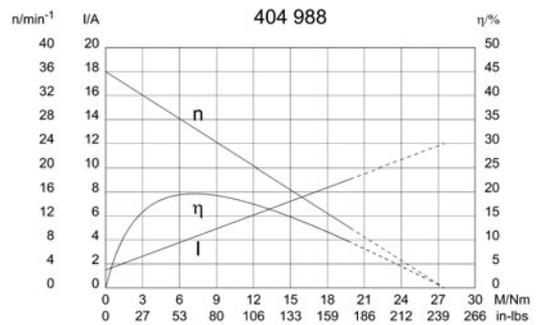

Output shaft drawing (W), Wiring diagrams (S) and Connector layout (K)

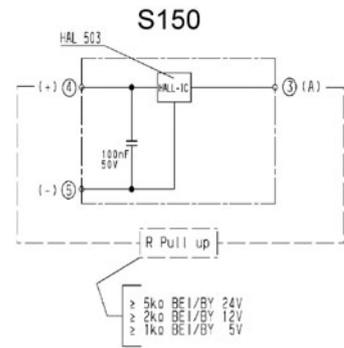
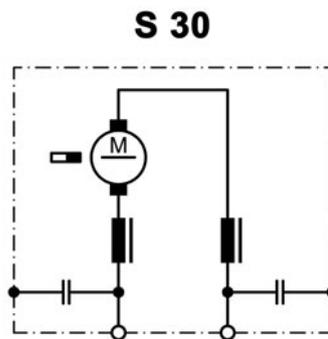
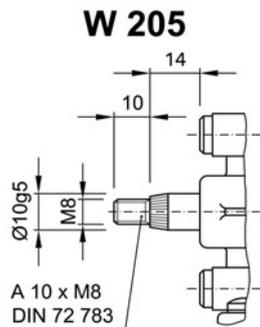

Design Data	
Commutation	Brushed
Direction of rotation	Bi-directional
Bearing type	A:Ball- B:Sleeve

Performance data		
Rated voltage [V]	U_N	24
Nominal torque [Nm]	M_N	1.00
No-load speed [min^{-1}]	n_0	270.0
Nominal power [W]	P_N	24.5
Nominal current [A]	I_N	3.0
Nominal force [kN]	F_N	0.00
Duty cycle	s1	

Sensor data	
Pulses	10.25
Output channels	1

Other data	
Gear ratio	41/4
Gear wheel material	plastic
Suppression components	$6\mu\text{H}$, 1nF
Enclosure class	IP 30
Weight [kg]	1.250

Remarks: d = for thread-forming screw M6 DIN ISO 965-2

Characteristic curves

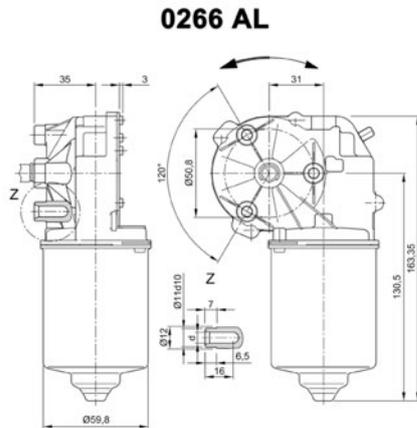

Motor picture

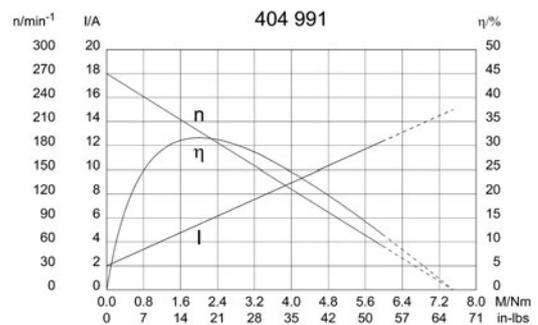

Output shaft drawing (W), Wiring diagrams (S) and Connector layout (K)

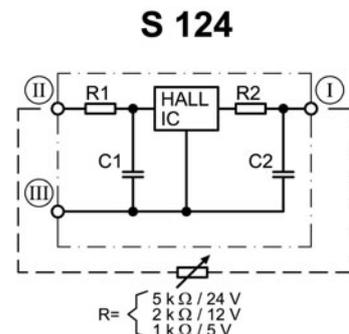
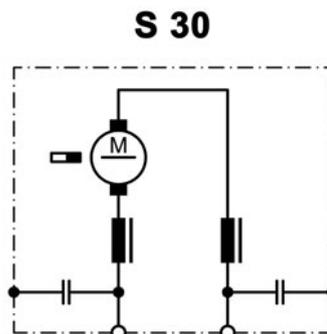
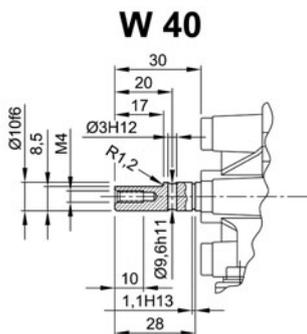

- I Terminal 3, A
- II Terminal 4, +
- III Terminal 5, -

Design Data	
Commutation	Brushed
Direction of rotation	Bi-directional
Bearing type	A:Ball - B:Sleeve

Performance data		
Rated voltage [V]	U_N	12
Nominal torque [Nm]	M_N	4.00
No-load speed [min^{-1}]	n_0	21.0
Nominal power [W]	P_N	7.79
Nominal current [A]	I_N	3.0
Nominal force [kN]	F_N	0.00
Duty cycle	s1	

Sensor data	
Pulses	0
Output channels	0

Other data	
Gear ratio	69/1
Gear wheel material	plastic
Suppression components	3,5 μ H, 1 μ F
Enclosure class	IP 30
Weight [kg]	1.210

Remarks: d = for thread-forming screw M6 DIN ISO 965-2

Characteristic curves

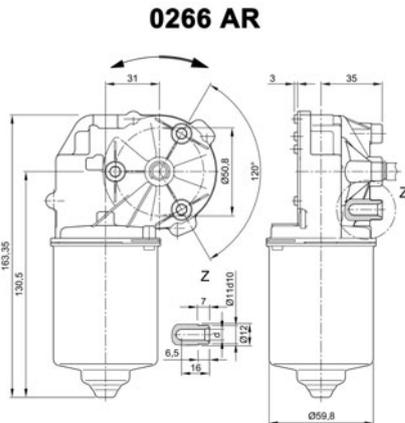

Motor picture

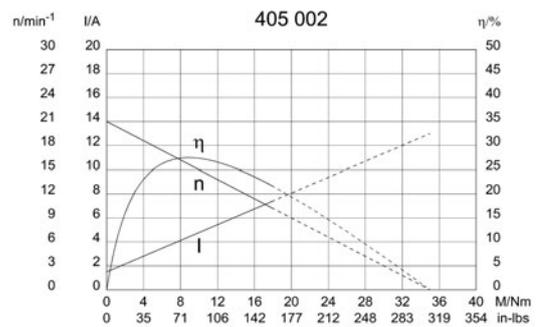

Output shaft drawing (W), Wiring diagrams (S) and Connector layout (K)

W 120

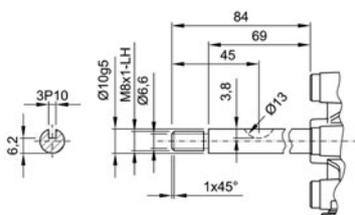

S 30

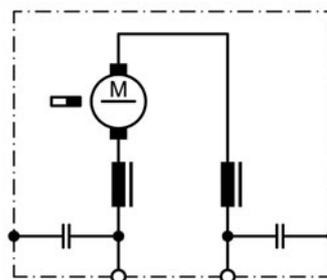

K 320

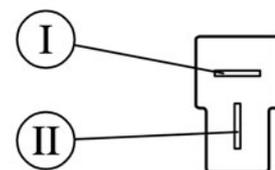

Flat plug (DIN 46244) 6,3x0,8 mating with receptacle housing part#180907, drwg# C-180907& Receptacles for tabs, conductor cross section 0,5-1,5 sqmm (20-18AWG) part# 925603-x, drwg# 925603 www.tycoelectronics.com

Design Data	
Commutation	Brushed
Direction of rotation	Bi-directional
Bearing type	A:Ball - B:Sleeve

Performance data		
Rated voltage [V]	U_N	24
Nominal torque [Nm]	M_N	4.00
No-load speed [min^{-1}]	n_0	65.0
Nominal power [W]	P_N	25.0
Nominal current [A]	I_N	3.0
Nominal force [kN]	F_N	0.00
Duty cycle	s1	

Sensor data	
Pulses	69
Output channels	2

Other data	
Gear ratio	69/1
Gear wheel material	plastic
Suppression components	6 μ H
Enclosure class	IP 30
Weight [kg]	1.250

Remarks: d = for thread-forming screw M6 DIN ISO 965-2

Characteristic curves

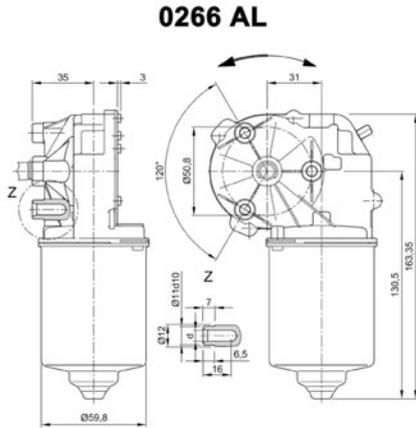

Motor picture

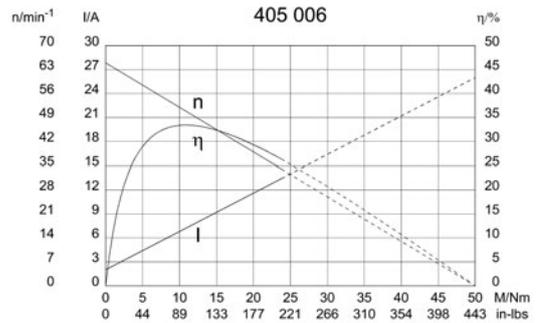

Output shaft drawing (W), Wiring diagrams (S) and Connector layout (K)

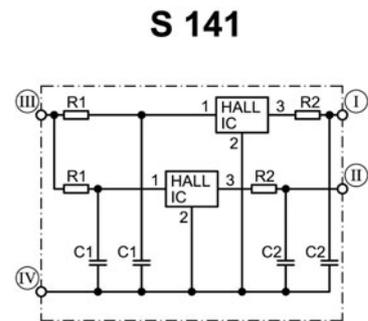
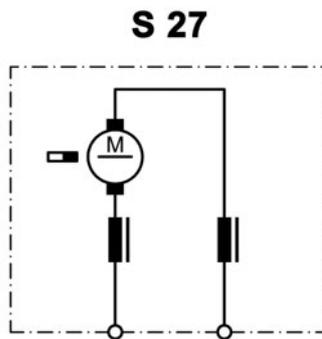
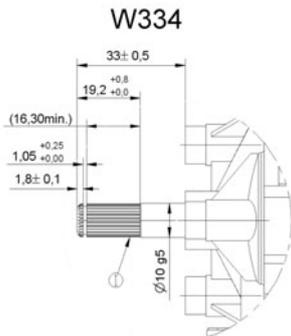

I serration (rolled): no of teeth 28, pitch circle dia 9 mm, tip circle dia 9.6 mm, root circle dia 8.26 mm space width angle 60° - go/no go gauge Frenco 33906 - www.frenco.de

I Hall-IC A1, terminal 3
 II Hall-IC A2, terminal 4
 III Hall-IC +, terminal 5
 IV Hall-IC -, terminal 6

Design Data	
Commutation	Brushed
Direction of rotation	Bi-directional
Bearing type	A:Ball - B:Sleeve

Performance data		
Rated voltage [V]	U_N	24
Nominal torque [Nm]	M_N	4.00
No-load speed [min^{-1}]	n_0	55.0
Nominal power [W]	P_N	21.5
Nominal current [A]	I_N	5.0
Nominal force [kN]	F_N	0.00
Duty cycle	s1	

Sensor data	
Pulses	78
Output channels	1

Other data	
Gear ratio	78/1
Gear wheel material	plastic
Suppression components	6 μ H, 1nF
Enclosure class	IP 30
Weight [kg]	1.210

Remarks: d= for thread forming screw M6 DIN ISO 965-2

Characteristic curves

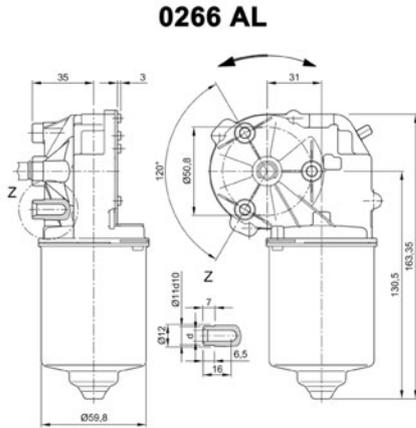

Motor picture

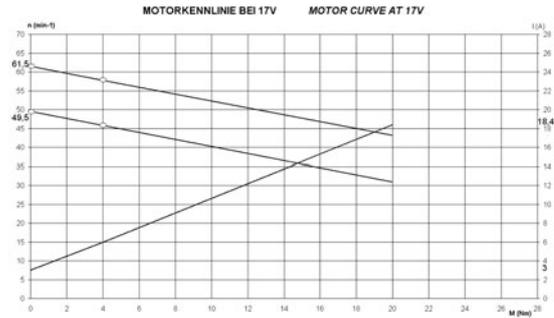

Output shaft drawing (W), Wiring diagrams (S) and Connector layout (K)

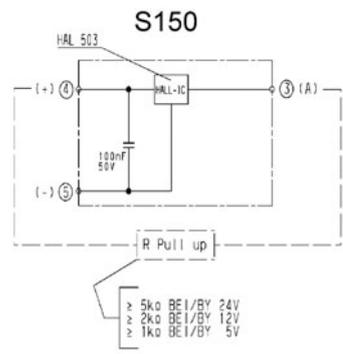
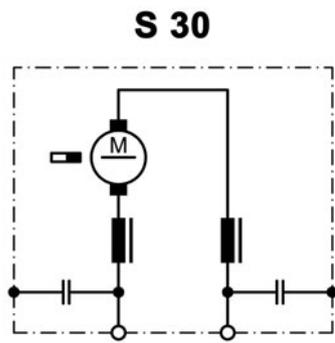
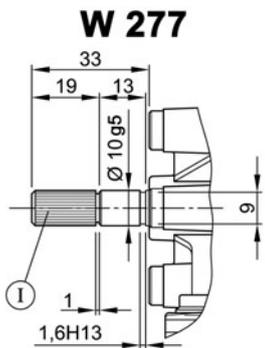

I serration (rolled)
 no of teeth 28, pitch circle dia 9 mm, tip circle dia 9,6 mm, root circle dia 8,26 mm space width angle 60°
 goes with go/no go gauge Frenco 33906
 www.frenco.de

Design Data	
Commutation	Brushed
Direction of rotation	Bi-directional
Bearing type	A:Ball - B:Sleeve

Performance data		
Rated voltage [V]	U_N	24
Nominal torque [Nm]	M_N	4.00
No-load speed [min^{-1}]	n_0	90.0
Nominal power [W]	P_N	35.9
Nominal current [A]	I_N	5.0
Nominal force [kN]	F_N	0.00
Duty cycle	s1	

Sensor data	
Pulses	69
Output channels	1

Other data	
Gear ratio	69/1
Gear wheel material	plastic
Suppression components	$6\mu\text{H}$, 1nF
Enclosure class	IP 30
Weight [kg]	1.210

Remarks: d=for thread forming screws M6 DIN-ISO 965-2

Characteristic curves

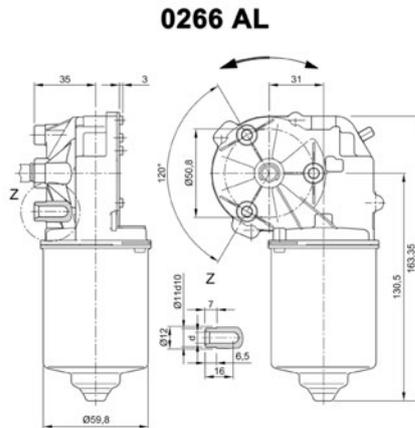

Motor picture

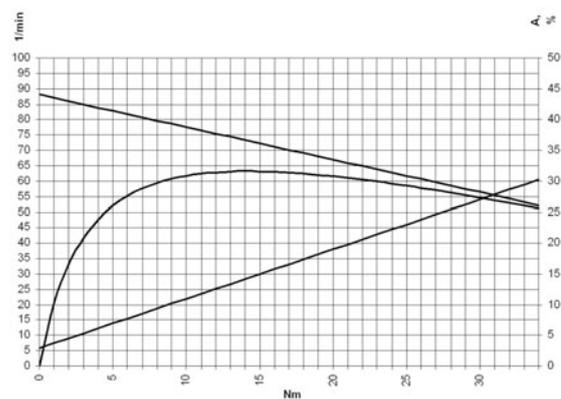

Output shaft drawing (W), Wiring diagrams (S) and Connector layout (K)

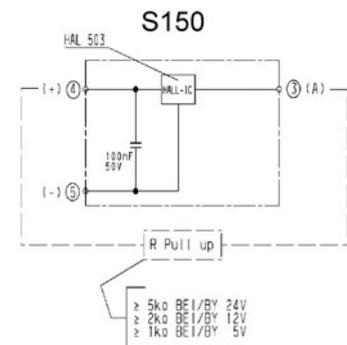
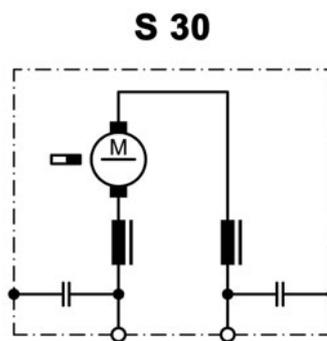
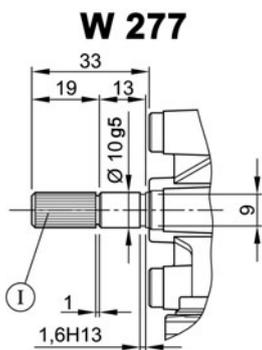

I serration (rolled)
 no of teeth 28, pitch circle dia 9 mm, tip circle dia 9.6 mm, root circle dia 8.26 mm space width angle 60°
 goes with go/no go gauge Frenco 33906
 www.frenco.de

Design Data	
Commutation	Brushed
Direction of rotation	Bi-directional
Bearing type	A: Ball - B: Sleeve

Performance data		
Rated voltage [V]	U_N	24
Nominal torque [Nm]	M_N	2.00
No-load speed [min^{-1}]	n_0	120.0
Nominal power [W]	P_N	22.0
Nominal current [A]	I_N	4.0
Nominal force [kN]	F_N	0.00
Duty cycle	s1	

Sensor data	
Pulses	79.5
Output channels	1

Other data	
Gear ratio	53/2
Gear wheel material	Plastic
Suppression components	6.0 μ H, 1nF
Enclosure class	IP30
Weight [kg]	1.210

Remarks: d = for thread-forming screw M6 DIN ISO 965-2

Characteristic curves

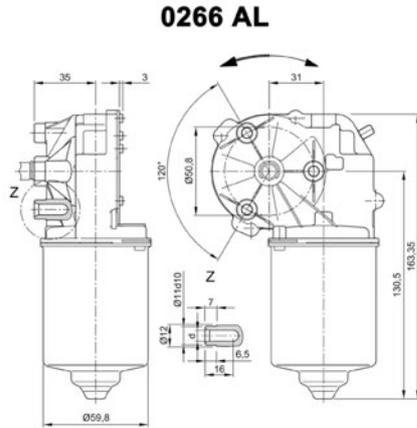

Motor picture

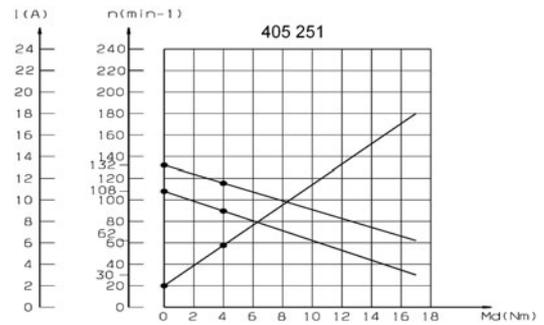

Output shaft drawing (W), Wiring diagrams (S) and Connector layout (K)

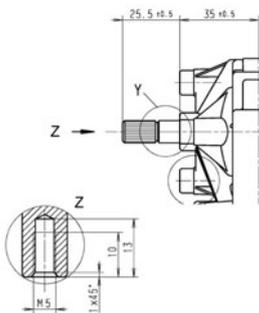

S 30

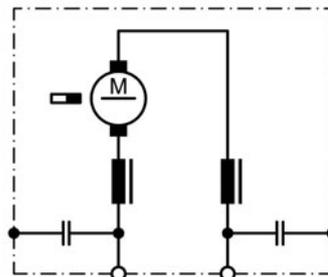

S 124

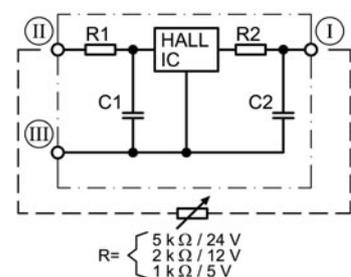

I serration (rolled): **No teeth 28, pitch circle dia 9 mm, tip circle dia 9.6 mm, root circle dia 8.26 mm space width angle 60° - go/no go gauge** Frenco 33906 - www.frenco.de

I Terminal 3, A
 II Terminal 4, +
 III Terminal 5, -



NIDEC MOTORS & ACTUATORS ❖❖❖ MOTOR SERIES

0268 (DCK35)

❖❖❖ DC MOTORS WITH WORM GEAR



❖❖❖ TECHNICAL DESCRIPTION

Motorhousing:	deep drawn & corrosion protected
Excitation field:	permanent magnet
Type of gear mesh:	worm gear
Gear housing:	zinc die cast
Gear wheel material:	plastic
Lubrication:	grease
Mechanical interface:	steel shaft
Electric interface:	connector
Sensor:	optional
Thermal protection:	optional
EMC suppression:	optional

❖❖❖ INDUSTRIAL APPLICATION

Home automation, machine construction

❖❖❖ AUTOMOTIVE APPLICATION

Trunk & tailgate opening & closing

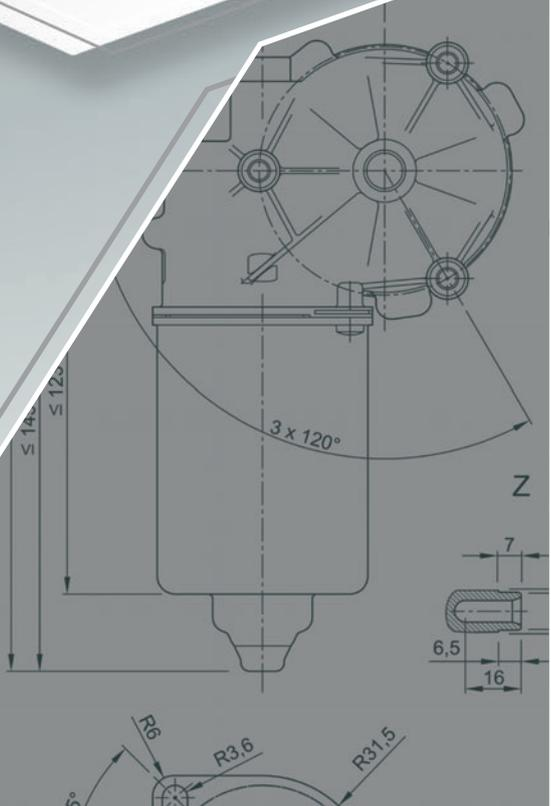

Design Data	
Commutation	Brushed
Direction of rotation	Bi-directional
Bearing type	A:Ball - B:Sleeve

Performance data		
Rated voltage [V]	U_N	24
Nominal torque [Nm]	M_N	6.00
No-load speed [min^{-1}]	n_0	50.0
Nominal power [W]	P_N	28.7
Nominal current [A]	I_N	4.0
Nominal force [kN]	F_N	0.00
Duty cycle	s1	

Sensor data	
Pulses	0
Output channels	0

Other data	
Gear ratio	63/1
Gear wheel material	plastic
Suppression components	3,5 μ H, 1nF
Enclosure class	IP 30
Weight [kg]	1.250

Remarks: d=for thread forming screws M6 DIN ISO 965-2

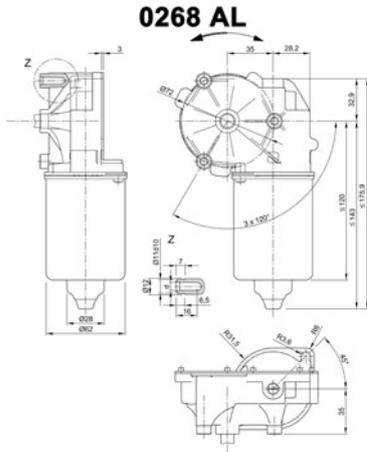

Motor picture



Characteristic curves

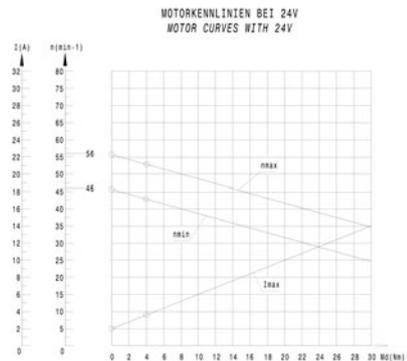

Output shaft drawing (W), Wiring diagrams (S) and Connector layout (K)

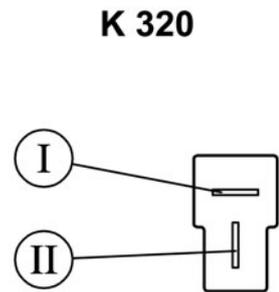
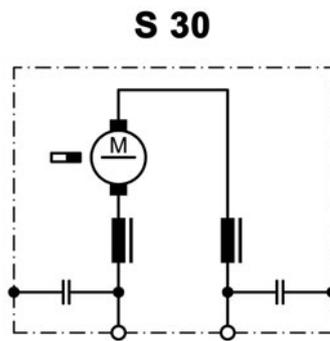
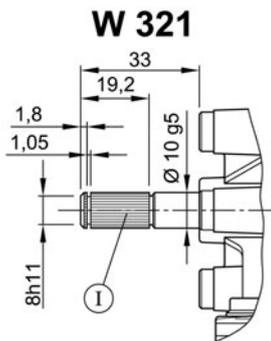

I serration (rolled): no of teeth 28, pitch circle dia 9 mm, tip circle dia 9.6 mm, root circle dia 8.26 mm space width angle 60°- go/no go gauge Frenco 33906 - www.frenco.de

Flat plug (DIN 46244) 6,3x0,8 mating with receptacle housing part#180907, drwg# C-180907& Receptacles for tabs, conductor cross section 0,5-1,5 sqmm (20-18AWG) part# 925603-x, drwg# 925603 www.tycoelectronics.com

Design Data	
Commutation	Brushed
Direction of rotation	Bi-directional
Bearing type	A:Ball - B:Sleeve

Performance data		
Rated voltage [V]	U_N	24
Nominal torque [Nm]	M_N	5.00
No-load speed [min^{-1}]	n_0	70.0
Nominal power [W]	P_N	33.5
Nominal current [A]	I_N	4.0
Nominal force [kN]	F_N	0.00
Duty cycle	s1	

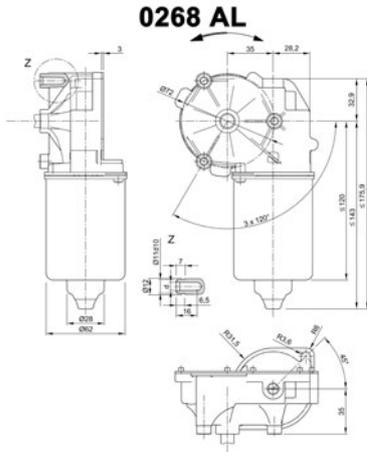

Sensor data	
Pulses	0
Output channels	0

Other data	
Gear ratio	55/1
Gear wheel material	plastic
Suppression components	3,5 μ H, 1nF
Enclosure class	IP 30
Weight [kg]	1.250

Remarks: d = for thread-forming screw M6 DIN ISO 965-2

Motor picture



Characteristic curves

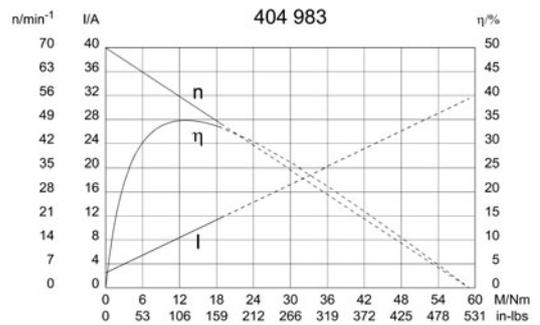

Output shaft drawing (W), Wiring diagrams (S) and Connector layout (K)

W 305

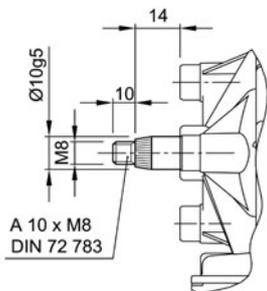

S 30

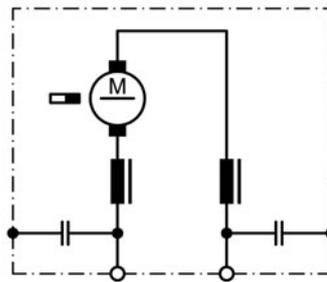

K 320

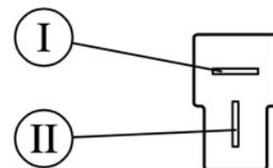

Flat plug (DIN 46244) 6,3x0,8 mating with receptacle housing part#180907, drwg# C-180907& Receptacles for tabs, conductor cross section 0,5-1,5 sqmm (20-18AWG) part# 925603-x, drwg# 925603 www.tycoelectronics.com

Design Data	
Commutation	Brushed
Direction of rotation	Bi-directional
Bearing type	A:Ball - B:Sleeve

Performance data		
Rated voltage [V]	U_N	24
Nominal torque [Nm]	M_N	6.00
No-load speed [min^{-1}]	n_0	60.0
Nominal power [W]	P_N	29.3
Nominal current [A]	I_N	7.0
Nominal force [kN]	F_N	0.00
Duty cycle	s1	

Sensor data	
Pulses	0
Output channels	0

Other data	
Gear ratio	63/1
Gear wheel material	plastic
Suppression components	3,5 μ H
Enclosure class	IP 30
Weight [kg]	1.376

Remarks:

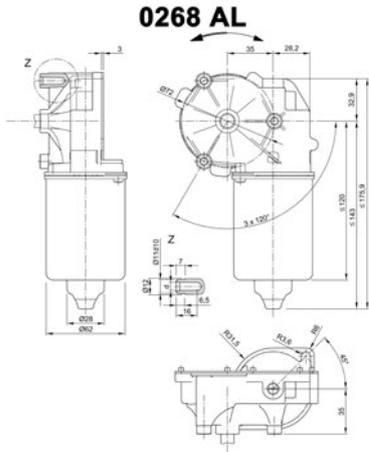

Motor picture



Characteristic curves

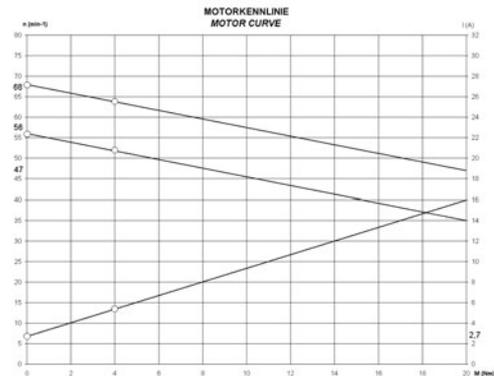

Output shaft drawing (W), Wiring diagrams (S) and Connector layout (K)

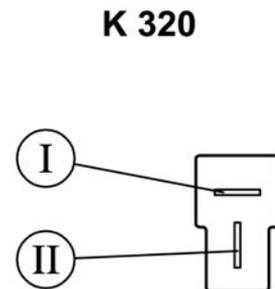
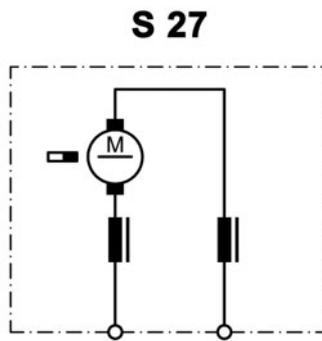
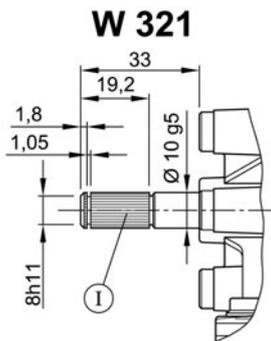

I serration (rolled): no of teeth 28, pitch circle dia 9 mm, tip circle dia 9.6 mm, root circle dia 8.26 mm space width angle 60°- go/no go gauge Frenco 33906 - www.frenco.de

Flat plug (DIN 46244) 6,3x0,8 mating with receptacle housing part#180907, drwg# C-180907& Receptacles for tabs, conductor cross section 0,5-1,5 sqmm (20-18AWG) part# 925603-x, drwg# 925603 www.tycoelectronics.com

Design Data	
Commutation	Brushed
Direction of rotation	Bi-directional
Bearing type	A: Ball - B: Sleeve

Performance data		
Rated voltage [V]	U_N	24
Nominal torque [Nm]	M_N	8.00
No-load speed [min^{-1}]	n_0	75.0
Nominal power [W]	P_N	37.7
Nominal current [A]	I_N	7.0
Nominal force [kN]	F_N	0.00
Duty cycle	s1	

Sensor data	
Pulses	63
Output channels	1

Other data	
Gear ratio	63/1
Gear wheel material	Plastic
Suppression components	3.5 μH
Enclosure class	IP30
Weight [kg]	1.250

Remarks: d = for thread-forming screw M6 DIN ISO 965-2

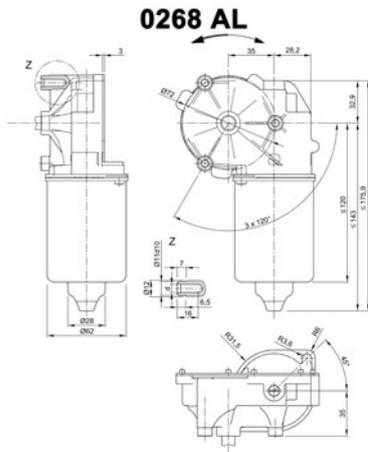

Motor picture

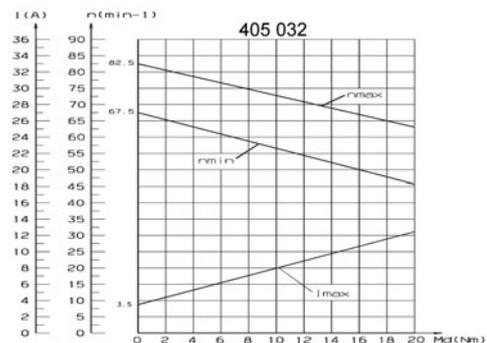

Output shaft drawing (W), Wiring diagrams (S) and Connector layout (K)

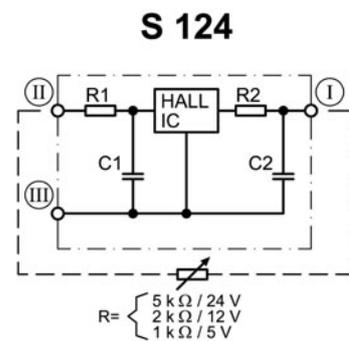
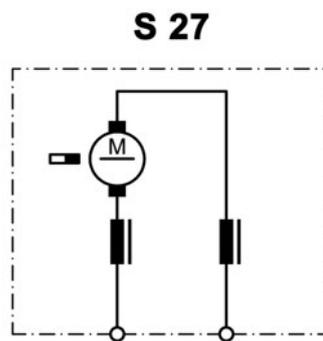
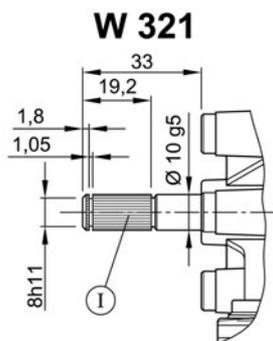

I serration (rolled): no of teeth 28, pitch circle dia 9 mm, tip circle dia 9.6 mm, root circle dia 8.26 mm space width angle 60°- go/no go gauge Frenco 33906 - www.frenco.de

I Terminal 3, A
 II Terminal 4, +
 III Terminal 5, -

$R = \begin{cases} 5 \text{ k}\Omega / 24 \text{ V} \\ 2 \text{ k}\Omega / 12 \text{ V} \\ 1 \text{ k}\Omega / 5 \text{ V} \end{cases}$

Design Data	
Commutation	Brushed
Direction of rotation	Bi-directional
Bearing type	A:Ball - B:Sleeve

Performance data		
Rated voltage [V]	U_N	24
Nominal torque [Nm]	M_N	8.00
No-load speed [min^{-1}]	n_0	53.0
Nominal power [W]	P_N	39.2
Nominal current [A]	I_N	6.0
Nominal force [kN]	F_N	0.00
Duty cycle	s1	

Sensor data	
Pulses	91
Output channels	1

Other data	
Gear ratio	91/1
Gear wheel material	plastic
Suppression components	3,5 μ H, 1nF
Enclosure class	IP 30
Weight [kg]	1.250

Remarks: d=for thread forming screws M6 DIN ISO 965-2

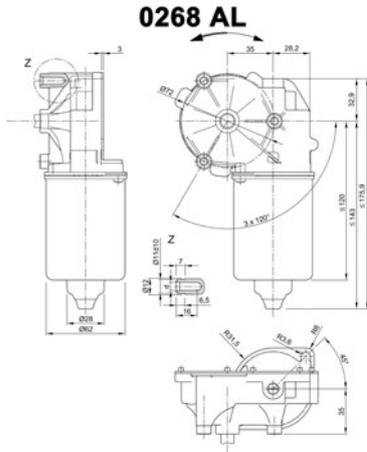

Motor picture



Characteristic curves

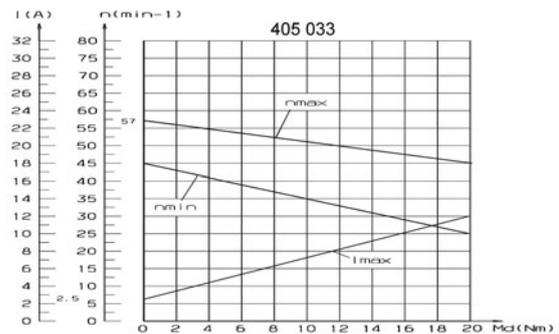

Output shaft drawing (W), Wiring diagrams (S) and Connector layout (K)

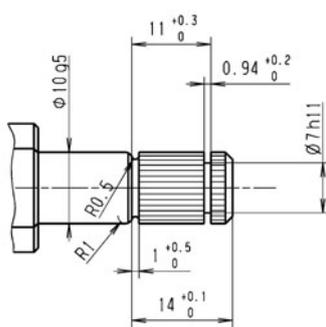

S 30

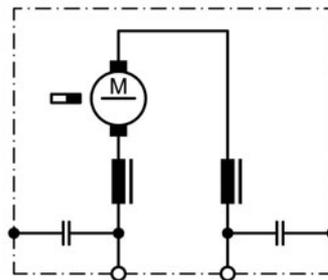

S 124

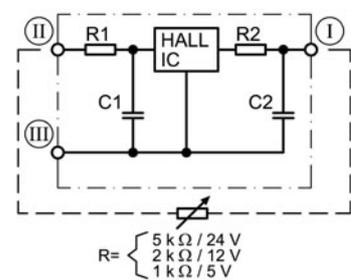

Splines: 8 x 10 (according to DIN 5481)
 Output shaft length = 28mm

I Terminal 3, A
 II Terminal 4, +
 III Terminal 5, -



NIDEC MOTORS & ACTUATORS ❖❖❖ MOTOR SERIES

0270 (SWMK)

❖❖❖ DC MOTORS WITH WORM GEAR

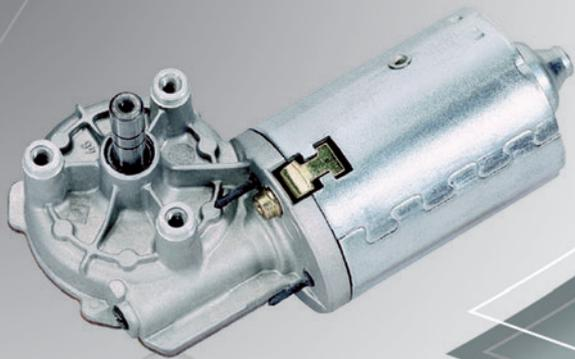

❖❖❖ TECHNICAL DESCRIPTION

Motorhousing:	rolled, corrosion protected
Excitation field:	permanent magnet
Type of gear mesh:	worm gear
Gear housing:	aluminium die cast
Gear wheel material:	plastic
Lubrication:	grease
Mechanical interface:	steel shaft
Electric interface:	connector or tinned leads
Sensor:	optional
Thermal protection:	optional
EMC suppression:	optional

❖❖❖ APPLICATION

Industry, Linear drives, General machinery,
 Vending machines, Agricultural technology,
 Office machines, Laboratory devices,
 Medical technology, Traffic & communications
 technology, Film/optics

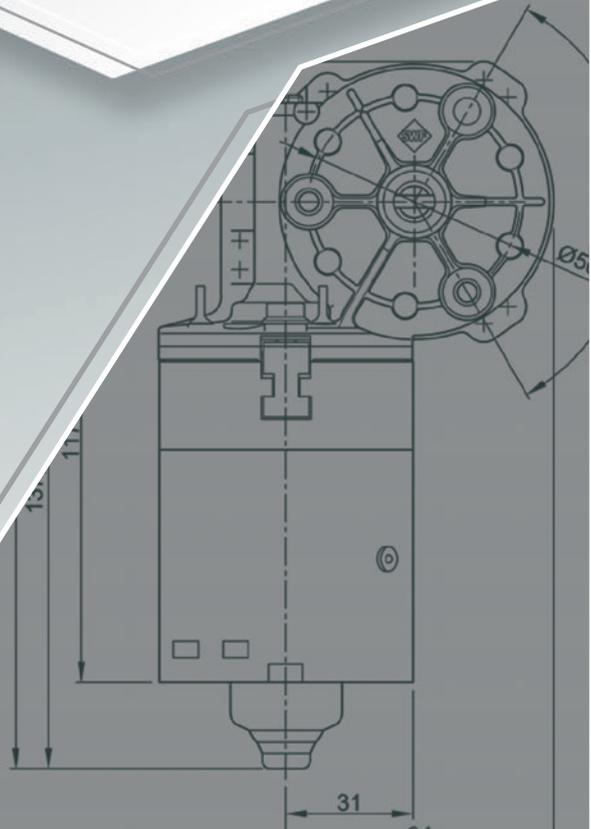

Design Data	
Commutation	Brushed
Direction of rotation	Bi-directional
Bearing type	

Performance data		
Rated voltage [V]	U_N	24
Nominal torque [Nm]	M_N	4.00
No-load speed [min^{-1}]	n_0	50.0
Nominal power [W]	P_N	17.7
Nominal current [A]	I_N	2.5
Nominal force [kN]	F_N	0.00
Duty cycle		s1

Sensor data	
Pulses	0
Output channels	0

Other data	
Gear ratio	55/1
Gear wheel material	Plastic
Suppression components	
Enclosure class	IP30
Weight [kg]	1.200

Remarks:

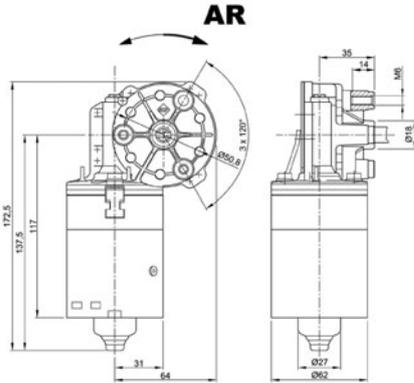

Motor picture



Characteristic curves

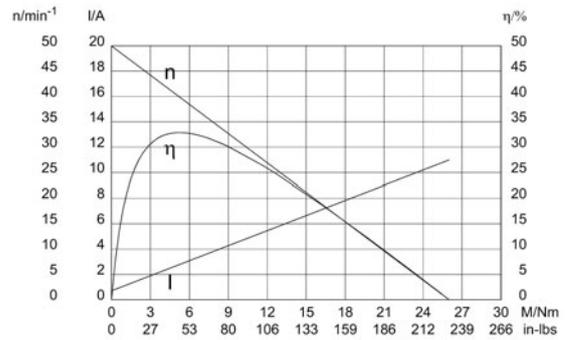

Output shaft drawing (W), Wiring diagrams (S) and Connector layout (K)

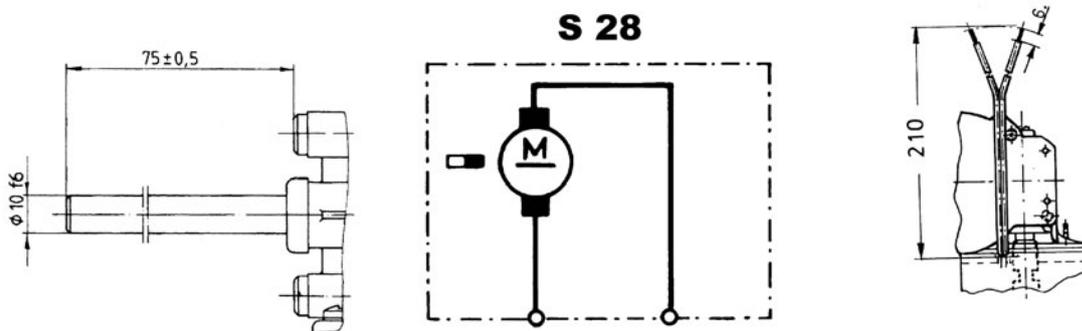

Design Data	
Commutation	Brushed
Direction of rotation	Bi-directional
Bearing type	

Performance data		
Rated voltage [V]	U_N	24
Nominal torque [Nm]	M_N	3.50
No-load speed [min^{-1}]	n_0	50.0
Nominal power [W]	P_N	15.9
Nominal current [A]	I_N	2.0
Nominal force [kN]	F_N	0.00
Duty cycle		s1

Sensor data	
Pulses	0
Output channels	0

Other data	
Gear ratio	55/1
Gear wheel material	Plastic
Suppression components	4.7 μ H, 1nF
Enclosure class	IP30
Weight [kg]	1.200

Remarks:

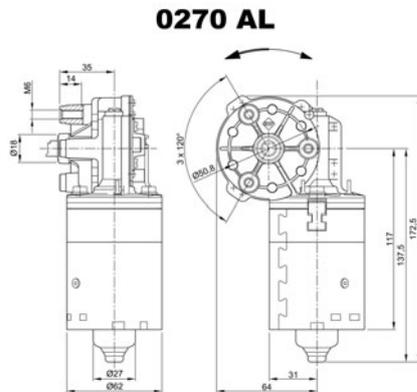

Motor picture



Characteristic curves

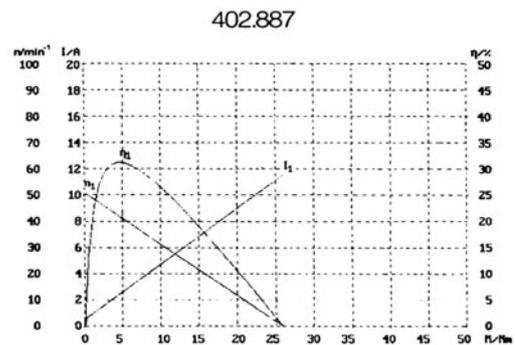

Output shaft drawing (W), Wiring diagrams (S) and Connector layout (K)

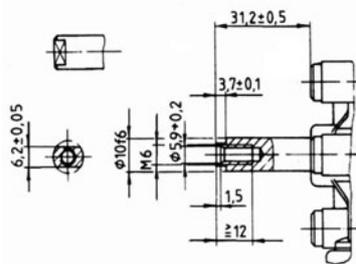

S 30

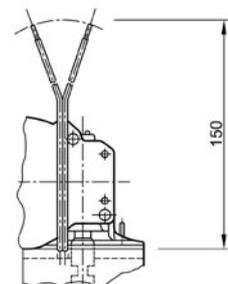
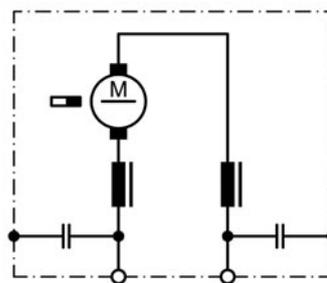

Design Data	
Commutation	Brushed
Direction of rotation	Bi-directional
Bearing type	

Performance data		
Rated voltage [V]	U_N	24
Nominal torque [Nm]	M_N	1.00
No-load speed [min^{-1}]	n_0	280.0
Nominal power [W]	P_N	24.9
Nominal current [A]	I_N	4.0
Nominal force [kN]	F_N	0.00
Duty cycle		s1

Sensor data	
Pulses	0
Output channels	0

Other data	
Gear ratio	41/4
Gear wheel material	Plastic
Suppression components	
Enclosure class	IP30
Weight [kg]	1.200

Remarks:

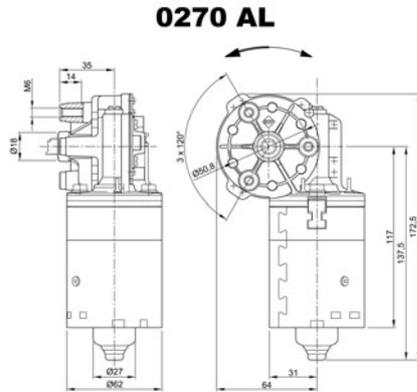

Motor picture



Characteristic curves

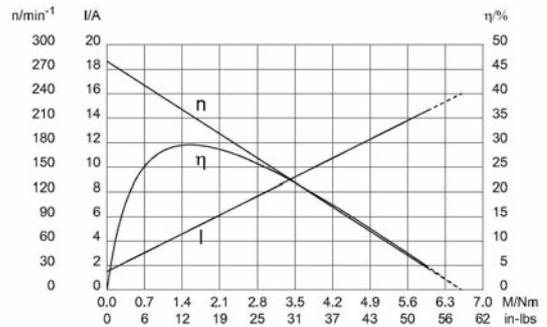

Output shaft drawing (W), Wiring diagrams (S) and Connector layout (K)

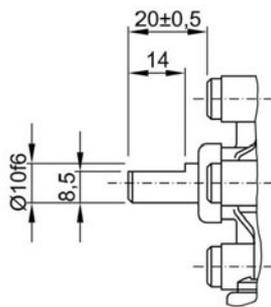

S 27

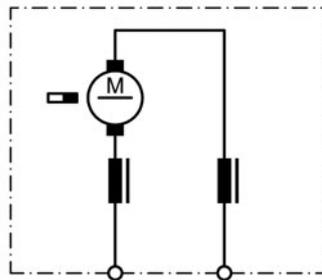

K 42

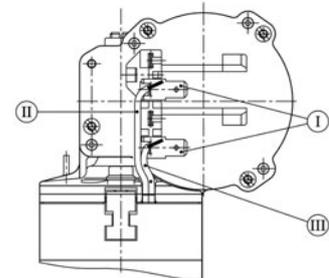

- I Blade terminal ends
6,3 x 0,8 DIN 46 244
- II green
- III red

Design Data	
Commutation	Brushed
Direction of rotation	Bi-directional
Bearing type	A: Ball - B: Sleeve

Performance data		
Rated voltage [V]	U_N	36
Nominal torque [Nm]	M_N	2.00
No-load speed [min^{-1}]	n_0	100.0
Nominal power [W]	P_N	18.3
Nominal current [A]	I_N	3.0
Nominal force [kN]	F_N	0.00
Duty cycle	s1	

Sensor data	
Pulses	0
Output channels	0

Other data	
Gear ratio	53/2
Gear wheel material	Plastic
Suppression components	4.7 μ H, 1nF
Enclosure class	IP30
Weight [kg]	1.200

Remarks:

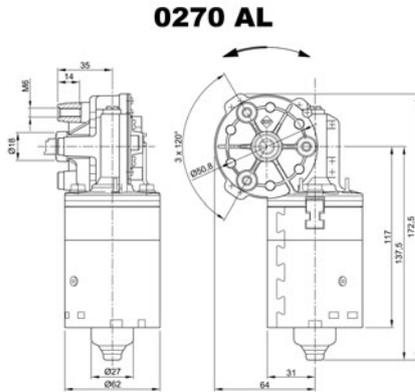

Motor picture



Characteristic curves

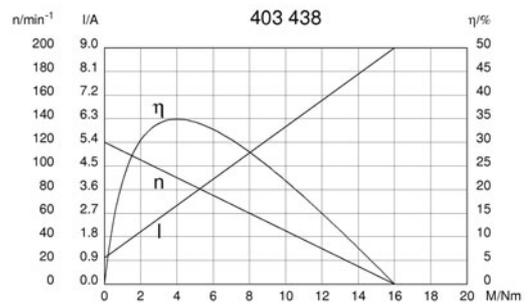

Output shaft drawing (W), Wiring diagrams (S) and Connector layout (K)

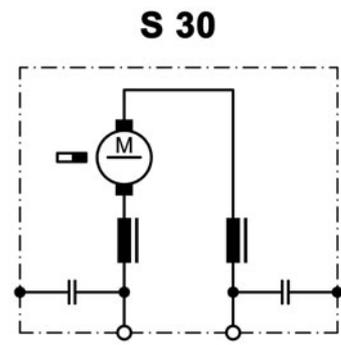
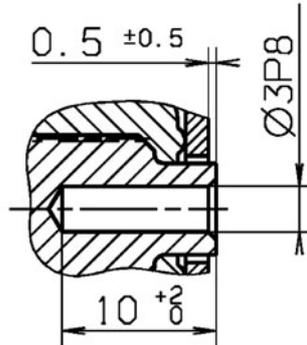
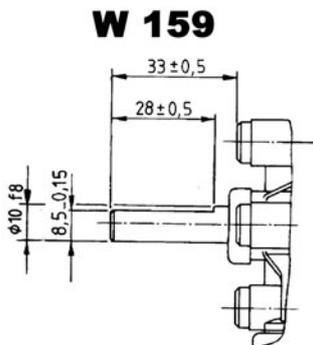

Design Data	
Commutation	Brushed
Direction of rotation	Bi-directional
Bearing type	

Performance data		
Rated voltage [V]	U_N	12
Nominal torque [Nm]	M_N	0.80
No-load speed [min^{-1}]	n_0	350.0
Nominal power [W]	P_N	27.0
Nominal current [A]	I_N	8.0
Nominal force [kN]	F_N	0.00
Duty cycle		s1

Sensor data	
Pulses	0
Output channels	0

Other data	
Gear ratio	41/4
Gear wheel material	plastic
Suppression components	""
Enclosure class	IP 30
Weight [kg]	1.200

Remarks:

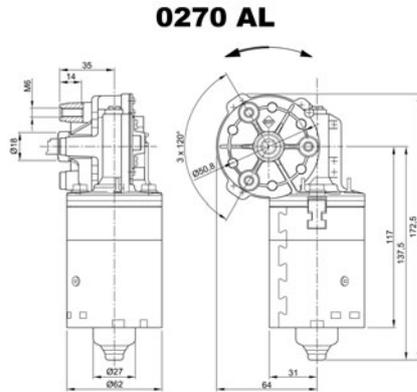

Motor picture



Characteristic curves

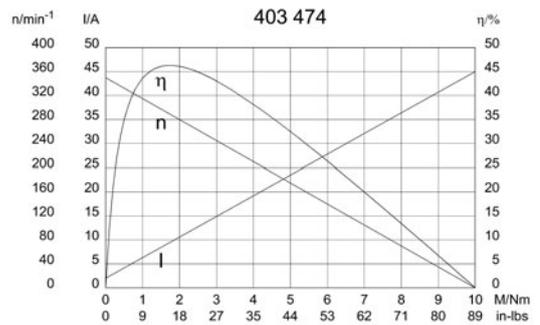

Output shaft drawing (W), Wiring diagrams (S) and Connector layout (K)

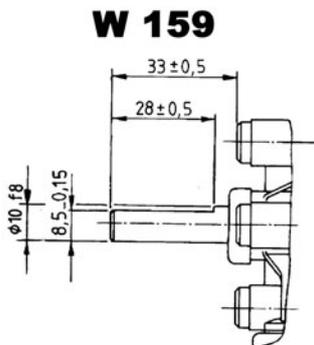

S 27

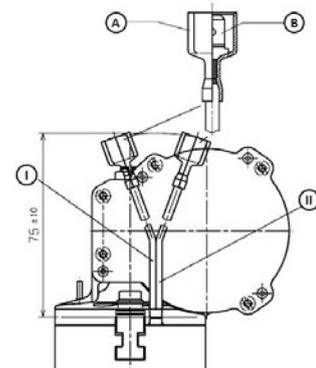
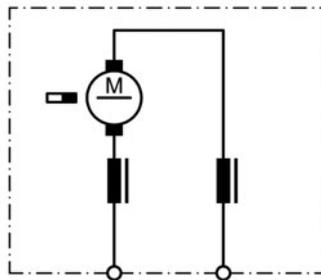

A: housing MST AMP No. 2-521055-2
 B: spade terminals 6.3 x 0.8 DIN 46 244
 I: red
 II: green

Design Data	
Commutation	Brushed
Direction of rotation	Bi-directional
Bearing type	

Performance data		
Rated voltage [V]	U_N	24
Nominal torque [Nm]	M_N	0.80
No-load speed [min^{-1}]	n_0	350.0
Nominal power [W]	P_N	27.0
Nominal current [A]	I_N	4.0
Nominal force [kN]	F_N	0.00
Duty cycle		s1

Sensor data	
Pulses	0
Output channels	0

Other data	
Gear ratio	41/4
Gear wheel material	plastic
Suppression components	1nF
Enclosure class	IP 30
Weight [kg]	1.200

Remarks:

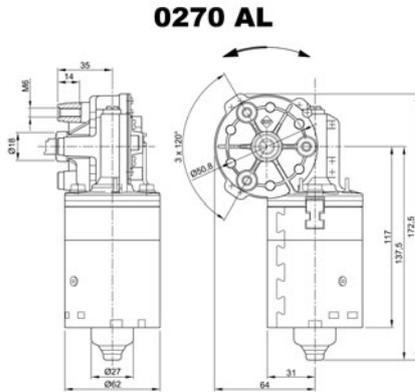

Motor picture



Characteristic curves

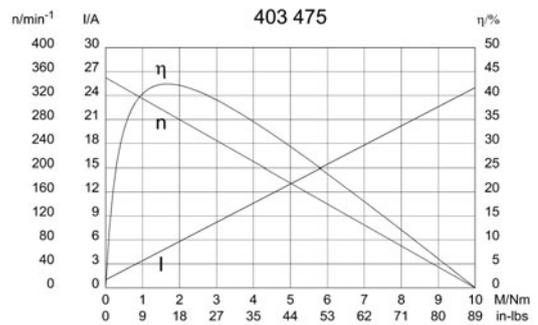

Output shaft drawing (W), Wiring diagrams (S) and Connector layout (K)

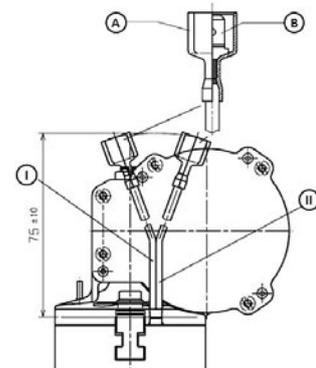
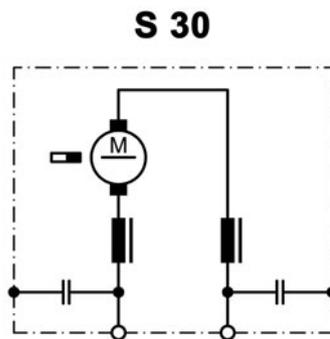
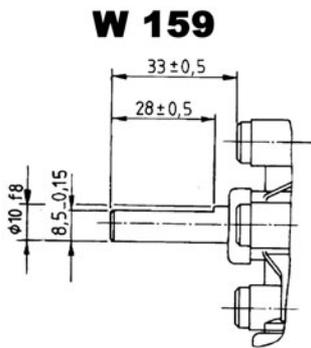

A: housing MST AMP No. 2-521055-2
 B: spade terminals 6.3 x 0.8 DIN 46 244
 I: red
 II: green

Design Data	
Commutation	Brushed
Direction of rotation	Bi-directional
Bearing type	

Performance data		
Rated voltage [V]	U_N	24
Nominal torque [Nm]	M_N	2.00
No-load speed [min^{-1}]	n_0	110.0
Nominal power [W]	P_N	20.8
Nominal current [A]	I_N	3.0
Nominal force [kN]	F_N	0.00
Duty cycle		s1

Sensor data	
Pulses	0
Output channels	0

Other data	
Gear ratio	53/2
Gear wheel material	Plastic
Suppression components	4.7 μ H, 1nF
Enclosure class	IP30
Weight [kg]	1.200

Remarks:

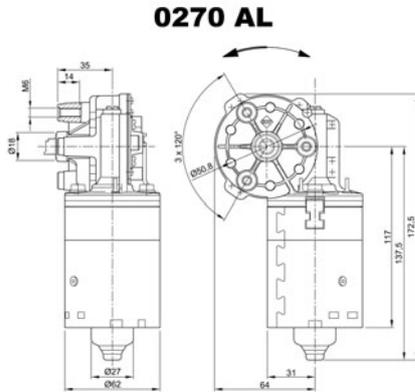

Motor picture



Characteristic curves

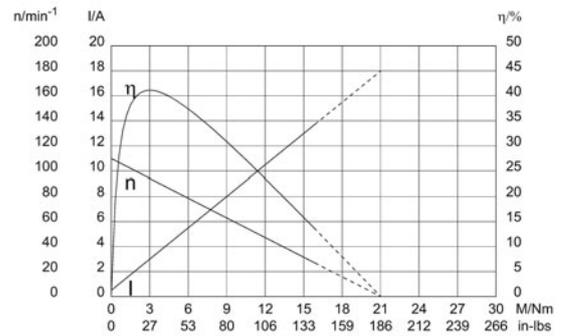

Output shaft drawing (W), Wiring diagrams (S) and Connector layout (K)

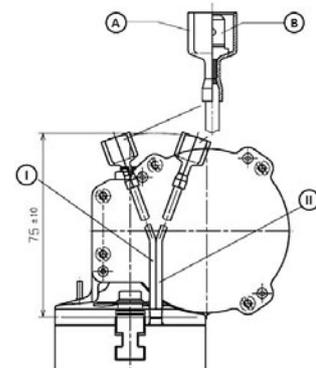
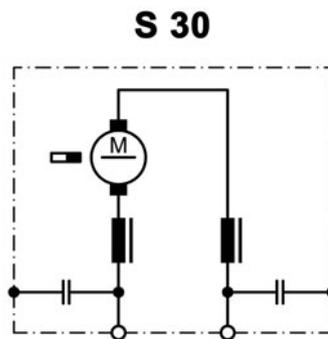
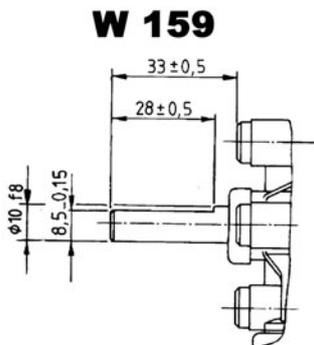

A: housing MST AMP No. 2-521055-2
 B: spade terminals 6.3 x 0.8 DIN 46 244
 I: red
 II: green

Design Data	
Commutation	Brushed
Direction of rotation	Bi-directional
Bearing type	

Performance data		
Rated voltage [V]	U_N	12
Nominal torque [Nm]	M_N	1.00
No-load speed [min^{-1}]	n_0	260.0
Nominal power [W]	P_N	23.0
Nominal current [A]	I_N	10.0
Nominal force [kN]	F_N	0.00
Duty cycle		s1

Sensor data	
Pulses	0
Output channels	0

Other data	
Gear ratio	41/4
Gear wheel material	Plastic
Suppression components	
Enclosure class	
Weight [kg]	1.200

Remarks:

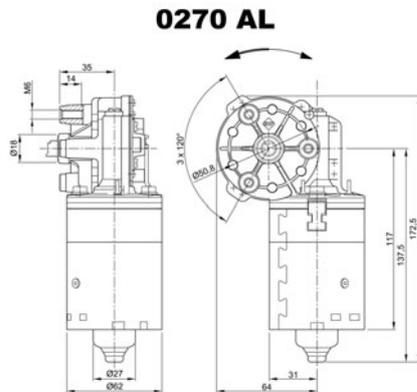

Motor picture



Characteristic curves

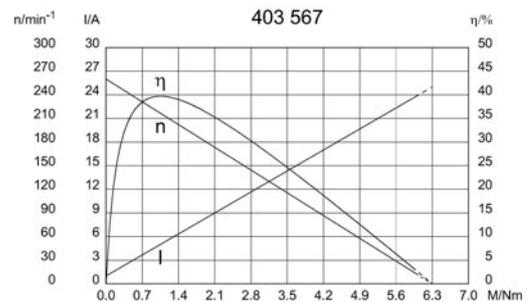

Output shaft drawing (W), Wiring diagrams (S) and Connector layout (K)

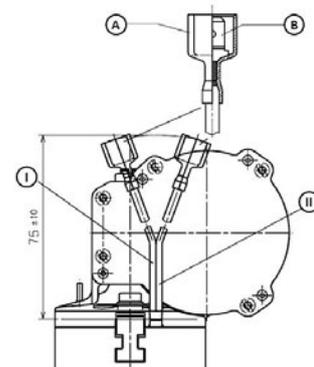
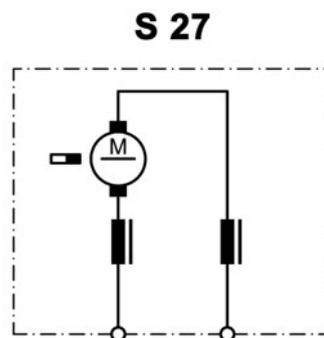
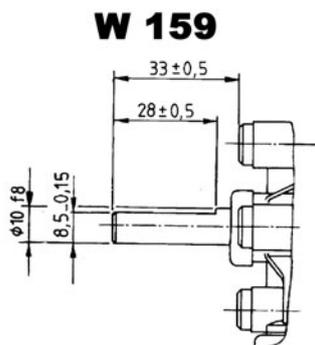

A: housing MST AMP No. 2-521055-2
 B: spade terminals 6.3 x 0.8 DIN 46 244
 I: red
 II: green

Design Data	
Commutation	Brushed
Direction of rotation	Bi-directional
Bearing type	

Performance data		
Rated voltage [V]	U_N	24
Nominal torque [Nm]	M_N	1.00
No-load speed [min^{-1}]	n_0	264.0
Nominal power [W]	P_N	23.2
Nominal current [A]	I_N	4.0
Nominal force [kN]	F_N	0.00
Duty cycle		s1

Sensor data	
Pulses	10.25
Output channels	1

Other data	
Gear ratio	41/4
Gear wheel material	Plastic
Suppression components	
Enclosure class	IP30
Weight [kg]	1.200

Remarks:

Motor picture

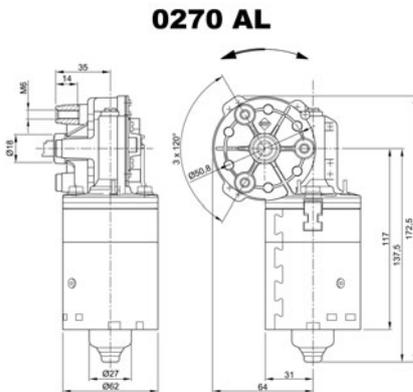

Characteristic curves

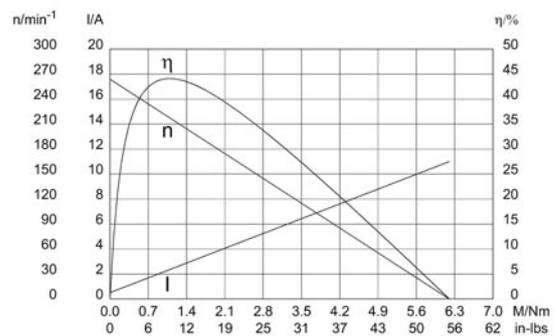

Output shaft drawing (W), Wiring diagrams (S) and Connector layout (K)

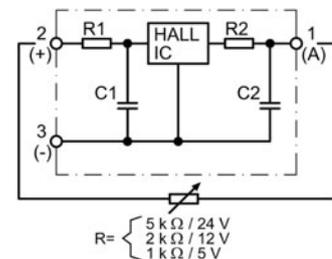
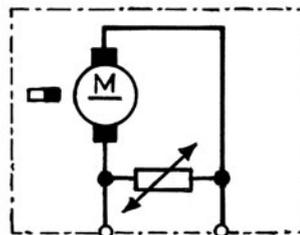
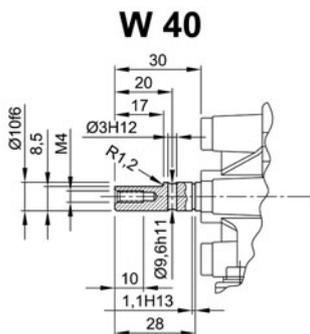



NIDEC MOTORS & ACTUATORS ❖❖❖ MOTOR SERIES

0277 (SW2K)

❖❖❖ DC MOTORS WITH WORM GEAR

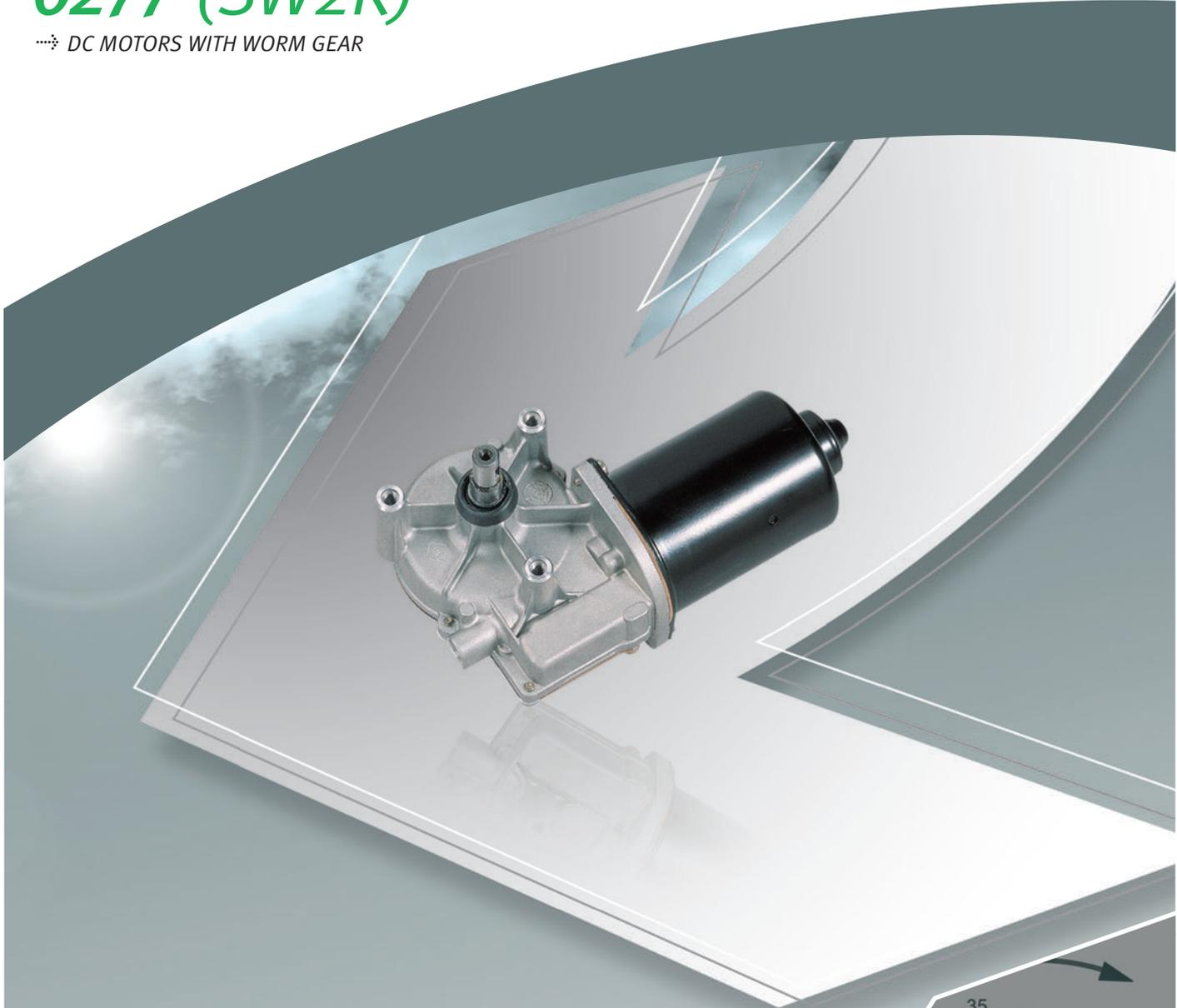

❖❖❖ TECHNICAL DESCRIPTION

Motorhousing:	deep drawn & corrosion protected
Excitation field:	permanent magnet
Type of gear mesh:	worm gear
Gear housing:	aluminium die cast
Gear wheel material:	plastic
Lubrication:	grease
Mechanical interface:	steel shaft
Electric interface:	connector or tinned leads
Sensor:	optional
Thermal protection:	optional
EMC suppression:	optional

❖❖❖ APPLICATION

Industry, Linear drives, General machinery,
 Vending machines, Agricultural technology,
 Office machines, Laboratory devices,
 Medical technology, Traffic & communications
 technology, Film/optics

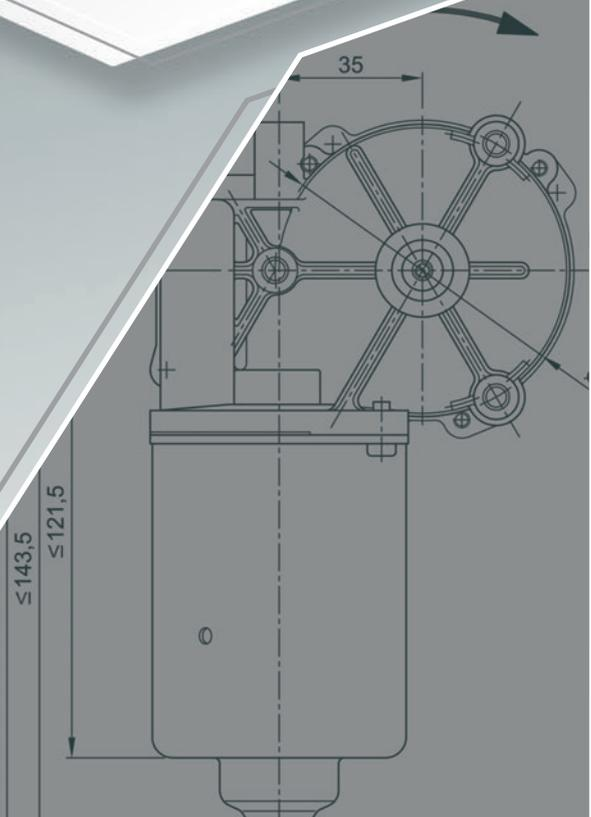

Design Data	
Commutation	Brushed
Direction of rotation	Bi-directional
Bearing type	

Performance data		
Rated voltage [V]	U_N	24
Nominal torque [Nm]	M_N	5.00
No-load speed [min^{-1}]	n_0	40.0
Nominal power [W]	P_N	16.8
Nominal current [A]	I_N	3.5
Nominal force [kN]	F_N	0.00
Duty cycle		s1

Sensor data	
Pulses	0
Output channels	0

Other data	
Gear ratio	78/1
Gear wheel material	Plastic
Suppression components	4.7 μ H, 1nF
Enclosure class	IP40
Weight [kg]	1.200

Remarks: Ball bearing

Characteristic curves

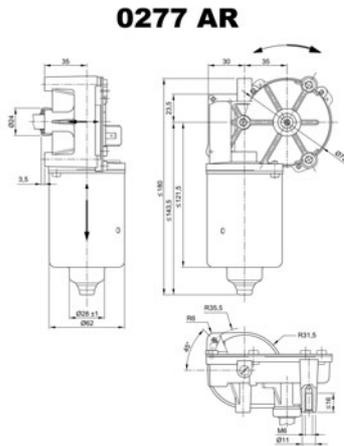

Motor picture

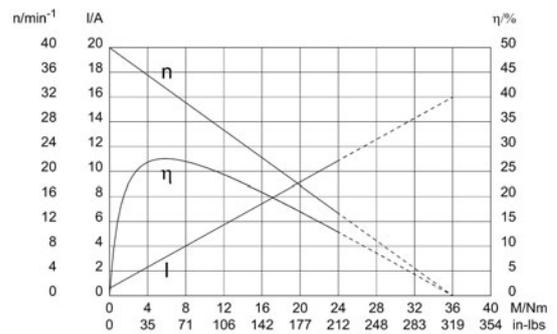

Output shaft drawing (W), Wiring diagrams (S) and Connector layout (K)

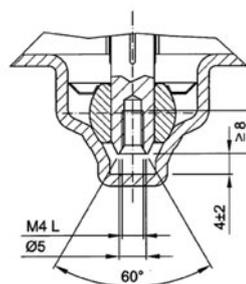
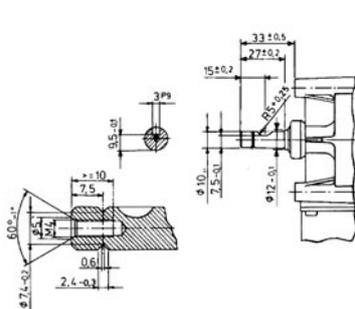

S 30

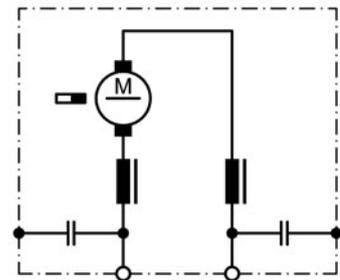

! Lefthand thread

Design Data	
Commutation	Brushed
Direction of rotation	Bi-directional
Bearing type	

Performance data		
Rated voltage [V]	U_N	24
Nominal torque [Nm]	M_N	2.00
No-load speed [min^{-1}]	n_0	230.0
Nominal power [W]	P_N	44.2
Nominal current [A]	I_N	6.0
Nominal force [kN]	F_N	0.00
Duty cycle		s1

Sensor data	
Pulses	0
Output channels	0

Other data	
Gear ratio	70/4
Gear wheel material	plastic
Suppression components	""
Enclosure class	IP 40
Weight [kg]	1.200

Remarks: Ball bearing

Characteristic curves

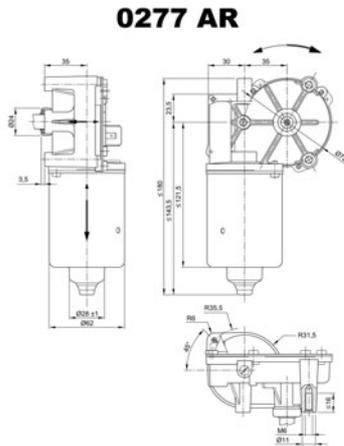

Motor picture

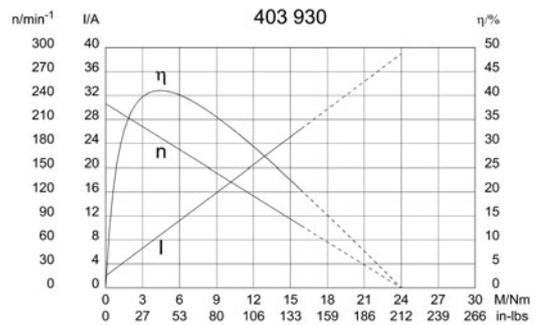

Output shaft drawing (W), Wiring diagrams (S) and Connector layout (K)

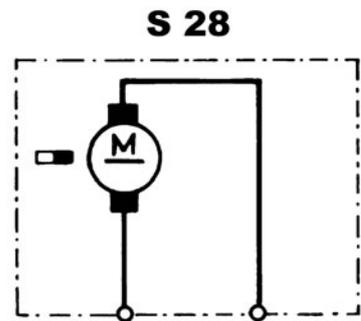
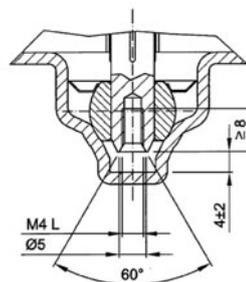
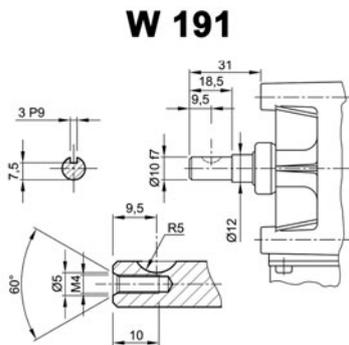

! Lefthand thread

Design Data	
Commutation	Brushed
Direction of rotation	Bi-directional
Bearing type	

Performance data		
Rated voltage [V]	U_N	24
Nominal torque [Nm]	M_N	2.00
No-load speed [min^{-1}]	n_0	230.0
Nominal power [W]	P_N	44.2
Nominal current [A]	I_N	6.0
Nominal force [kN]	F_N	0.00
Duty cycle		s1

Sensor data	
Pulses	0
Output channels	0

Other data	
Gear ratio	70/4
Gear wheel material	plastic
Suppression components	""
Enclosure class	IP 40
Weight [kg]	1.200

Remarks: Ball bearing

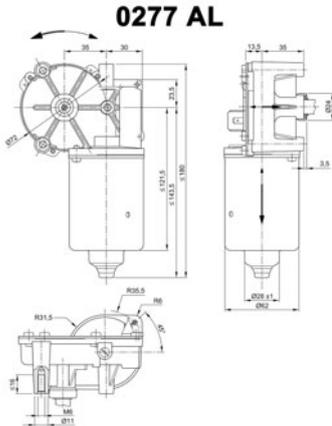

Motor picture



Characteristic curves

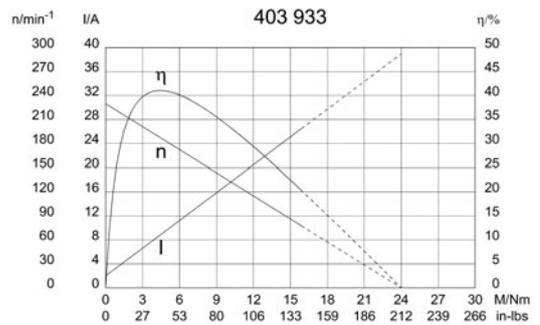

Output shaft drawing (W), Wiring diagrams (S) and Connector layout (K)

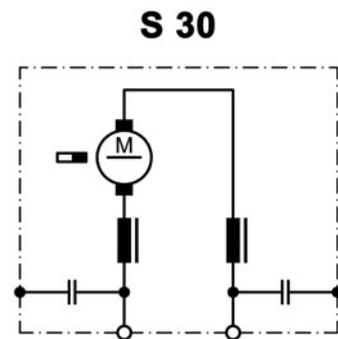
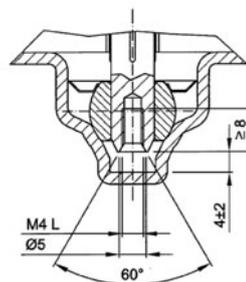
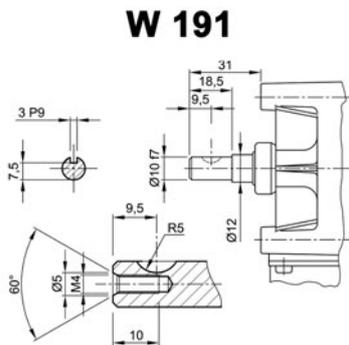

! Lefthand thread

Design Data	
Commutation	Brushed
Direction of rotation	Bi-directional
Bearing type	

Performance data		
Rated voltage [V]	U_N	24
Nominal torque [Nm]	M_N	5.00
No-load speed [min^{-1}]	n_0	54.0
Nominal power [W]	P_N	26.3
Nominal current [A]	I_N	5.0
Nominal force [kN]	F_N	0.00
Duty cycle		s1

Sensor data	
Pulses	0
Output channels	0

Other data	
Gear ratio	78/1
Gear wheel material	plastic
Suppression components	$5\mu\text{H}$, 1nF
Enclosure class	IP 40
Weight [kg]	1.200

Remarks:

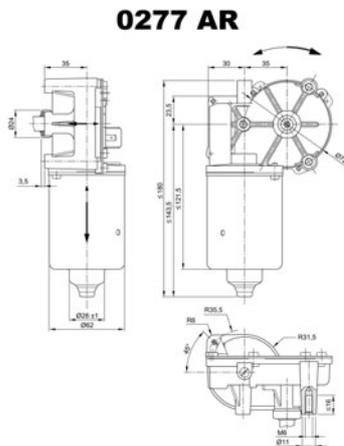

Motor picture



Characteristic curves

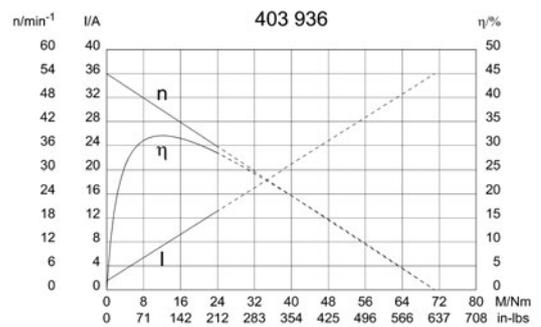

Output shaft drawing (W), Wiring diagrams (S) and Connector layout (K)

W 194

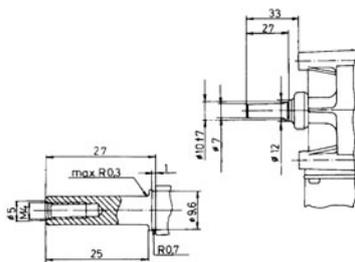

S 30

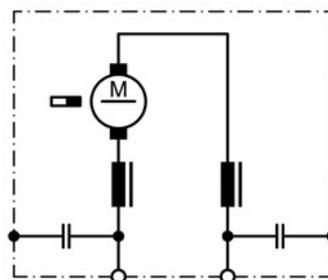

K 144

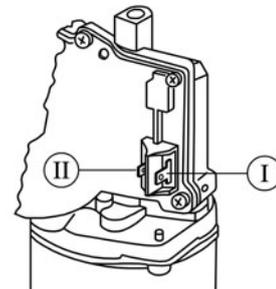

I - Blade terminal ends 6,3 x 0,8 DIN 46 244
 II - Blade terminal ends 4,8 x 0,8 DIN 46 244

Design Data	
Commutation	Brushed
Direction of rotation	Bi-directional
Bearing type	A: Ball - B: Sleeve

Performance data		
Rated voltage [V]	U_N	24
Nominal torque [Nm]	M_N	5.00
No-load speed [min^{-1}]	n_0	40.0
Nominal power [W]	P_N	16.8
Nominal current [A]	I_N	3.0
Nominal force [kN]	F_N	0.00
Duty cycle	s1	

Sensor data	
Pulses	0
Output channels	0

Other data	
Gear ratio	78/1
Gear wheel material	Plastic
Suppression components	
Enclosure class	IP40
Weight [kg]	1.200

Remarks:

0277 AR

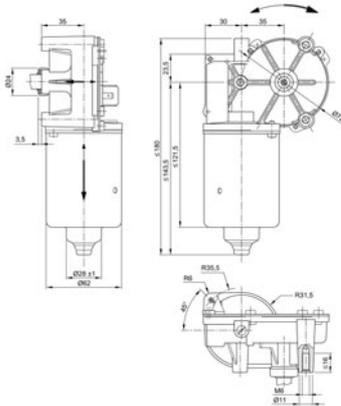

Motor picture



Characteristic curves

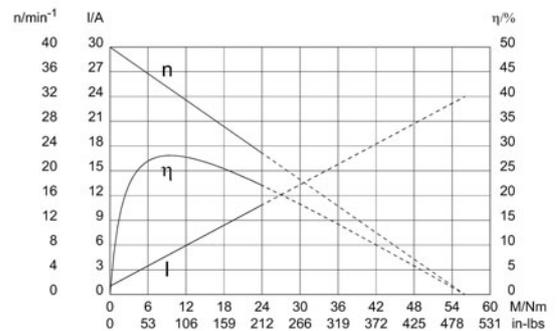

Output shaft drawing (W), Wiring diagrams (S) and Connector layout (K)

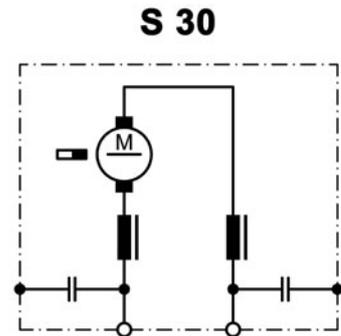
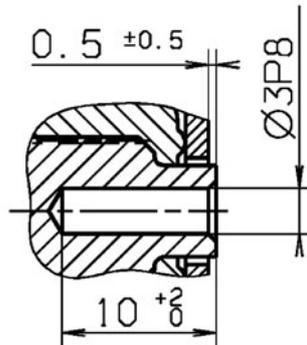
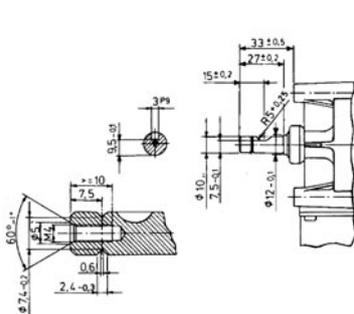

Design Data	
Commutation	Brushed
Direction of rotation	Bi-directional
Bearing type	

Performance data		
Rated voltage [V]	U_N	24
Nominal torque [Nm]	M_N	5.00
No-load speed [min^{-1}]	n_0	65.0
Nominal power [W]	P_N	27.2
Nominal current [A]	I_N	4.0
Nominal force [kN]	F_N	0.00
Duty cycle		s1

Sensor data	
Pulses	0
Output channels	0

Other data	
Gear ratio	63/1
Gear wheel material	Plastic
Suppression components	4.7 μ H, 1nF
Enclosure class	IP40
Weight [kg]	1.200

Remarks: Ball bearing

Characteristic curves

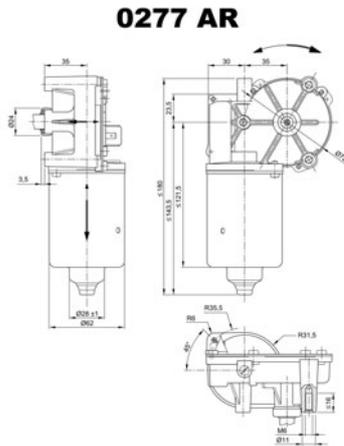

Motor picture

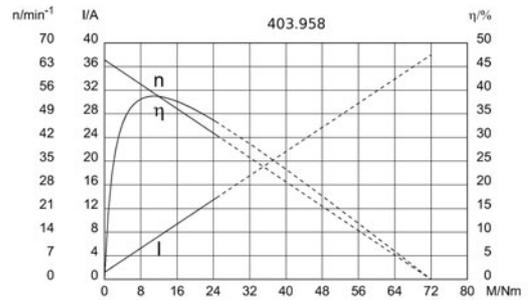

Output shaft drawing (W), Wiring diagrams (S) and Connector layout (K)

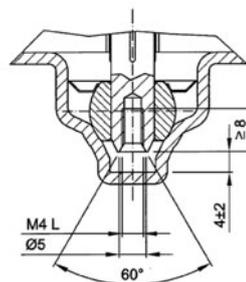
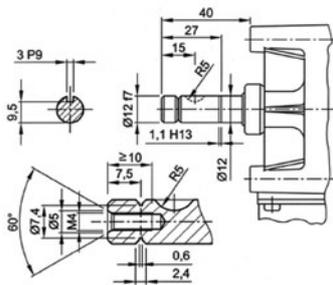

S 30

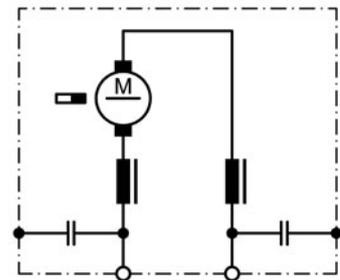

! Lefthand thread

Design Data	
Commutation	Brushed
Direction of rotation	Bi-directional
Bearing type	

Performance data		
Rated voltage [V]	U_N	12
Nominal torque [Nm]	M_N	3.00
No-load speed [min^{-1}]	n_0	270.0
Nominal power [W]	P_N	68.9
Nominal current [A]	I_N	15.0
Nominal force [kN]	F_N	0.00
Duty cycle		s1

Sensor data	
Pulses	0
Output channels	0

Other data	
Gear ratio	70/4
Gear wheel material	plastic
Suppression components	1.9 μ H, 1 μ F
Enclosure class	IP 40
Weight [kg]	1.200

Remarks: Ball bearing

Characteristic curves

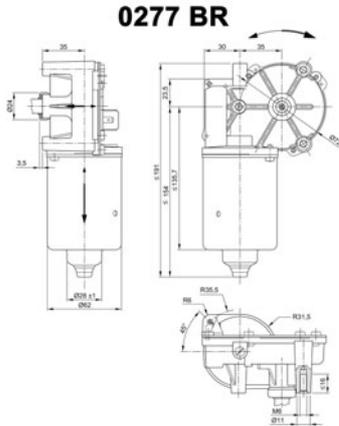

Motor picture

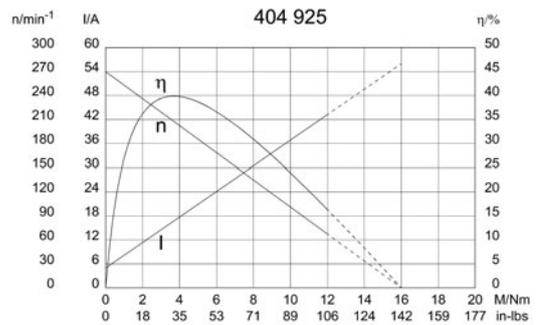

Output shaft drawing (W), Wiring diagrams (S) and Connector layout (K)

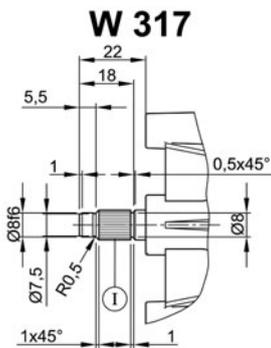

S 30

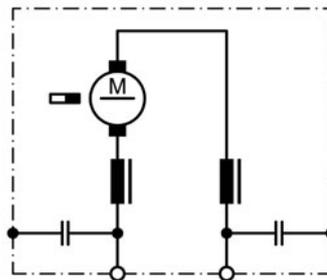

K 144

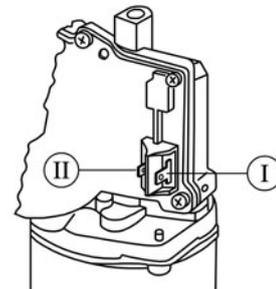

I Tapered splines 8 x 10 f
(similar DIN 5481)

I Blade terminal ends 6,3 x 0,8 DIN 46 244
II Blade terminal ends 4,8 x 0,8 DIN 46 244



NIDEC MOTORS & ACTUATORS ❖❖❖ MOTOR SERIES

0278 (SW2L)

❖❖❖ DC MOTORS WITH WORM GEAR

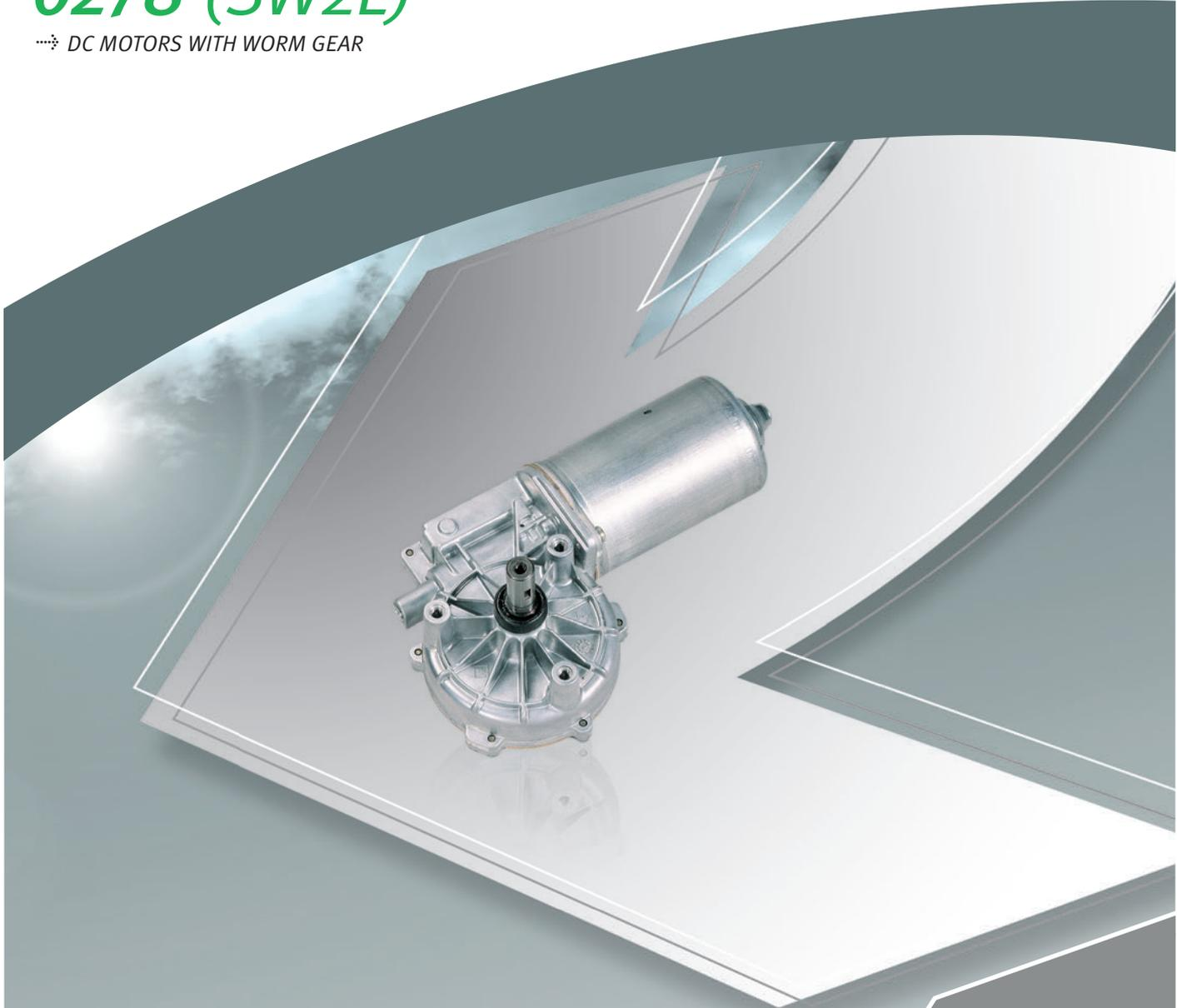

❖❖❖ TECHNICAL DESCRIPTION

Motorhousing:	deep drawn & corrosion protected
Excitation field:	permanent magnet
Type of gear mesh:	worm gear
Gear housing:	aluminium die cast
Gear wheel material:	plastic
Lubrication:	grease
Mechanical interface:	steel shaft
Electric interface:	connector
Sensor:	optional
Thermal protection:	optional
EMC suppression:	optional

❖❖❖ INDUSTRIAL APPLICATION

Gate Opener, Patient Hoist,
Machine construction

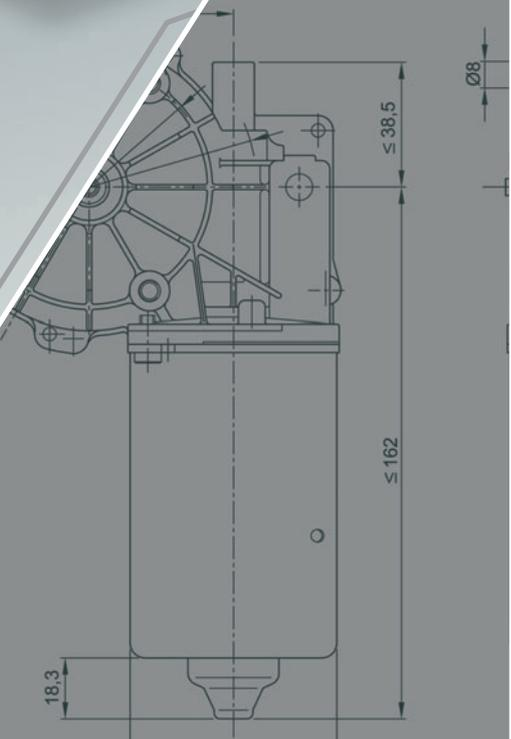

Design Data	
Commutation	Brushed
Direction of rotation	Bi-directional
Bearing type	A:Ball - B:Sleeve

Performance data		
Rated voltage [V]	U_N	24
Nominal torque [Nm]	M_N	6.00
No-load speed [min^{-1}]	n_0	48.0
Nominal power [W]	P_N	27.9
Nominal current [A]	I_N	6.0
Nominal force [kN]	F_N	0.00
Duty cycle	s1	

Sensor data	
Pulses	0
Output channels	0

Other data	
Gear ratio	74/1
Gear wheel material	plastic
Suppression components	4,7 μ H, 1 μ F
Enclosure class	IP40
Weight [kg]	1.716

Remarks:

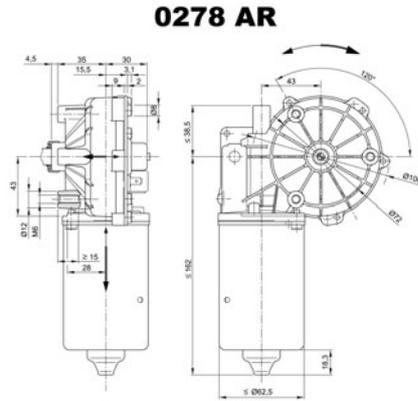

Motor picture



Characteristic curves

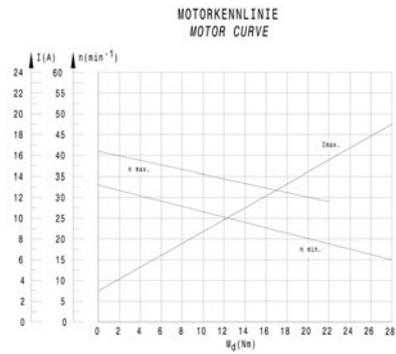

Output shaft drawing (W), Wiring diagrams (S) and Connector layout (K)

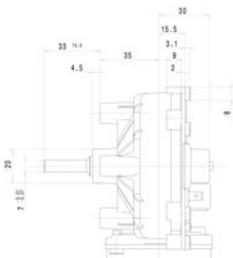

S 30

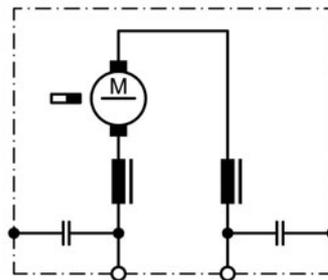

K 144

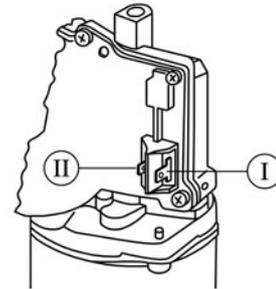

- I - Blade terminal ends 6,3 x 0,8 DIN 46 244
- II - Blade terminal ends 4,8 x 0,8 DIN 46 244

Design Data	
Commutation	Brushed
Direction of rotation	Bi-directional
Bearing type	A:Ball - B:Sleeve

Performance data		
Rated voltage [V]	U_N	24
Nominal torque [Nm]	M_N	4.00
No-load speed [min^{-1}]	n_0	190.0
Nominal power [W]	P_N	73.1
Nominal current [A]	I_N	7.0
Nominal force [kN]	F_N	0.00
Duty cycle	s1	

Sensor data	
Pulses	0
Output channels	0

Other data	
Gear ratio	103/4
Gear wheel material	plastic
Suppression components	4,7 μ H, 1nF
Enclosure class	IP 40
Weight [kg]	1.700

Remarks:

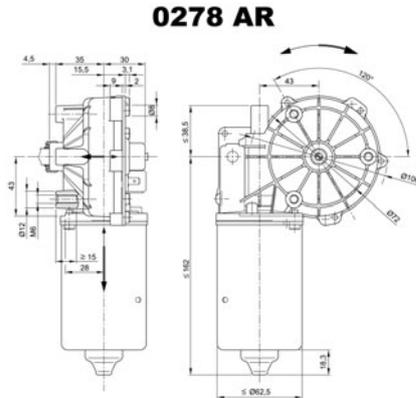

Motor picture



Characteristic curves

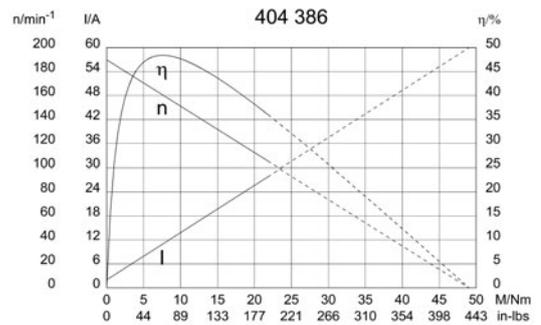

Output shaft drawing (W), Wiring diagrams (S) and Connector layout (K)

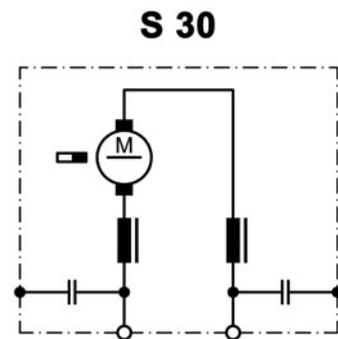
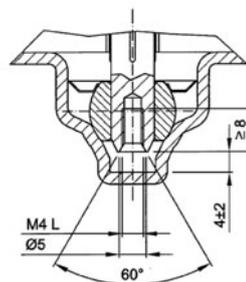
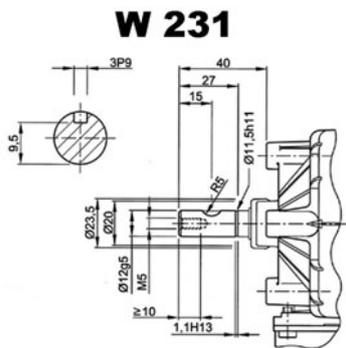

! Lefthand thread

Design Data	
Commutation	Brushed
Direction of rotation	Bi-directional
Bearing type	A:Ball - B:Sleeve

Performance data		
Rated voltage [V]	U_N	24
Nominal torque [Nm]	M_N	6.00
No-load speed [min^{-1}]	n_0	48.0
Nominal power [W]	P_N	21.9
Nominal current [A]	I_N	4.0
Nominal force [kN]	F_N	0.00
Duty cycle	s1	

Sensor data	
Pulses	74
Output channels	1

Other data	
Gear ratio	74/1
Gear wheel material	plastic
Suppression components	4,7 μ H, 1nF
Enclosure class	IP40
Weight [kg]	1.730

Remarks:

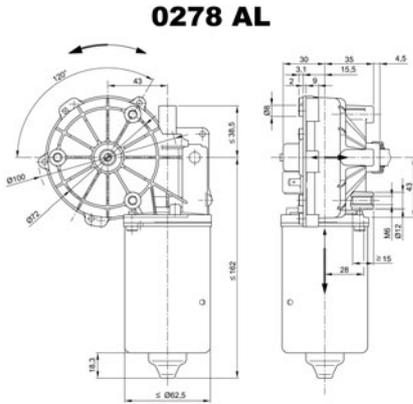

Motor picture



Characteristic curves

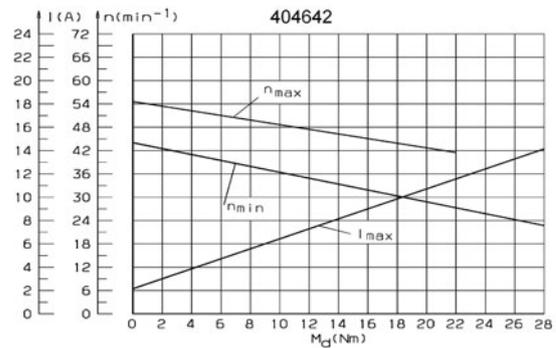

Output shaft drawing (W), Wiring diagrams (S) and Connector layout (K)

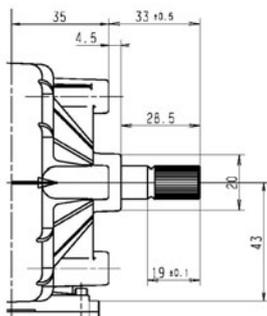

S 74

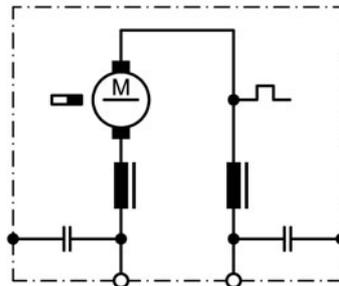

S 124

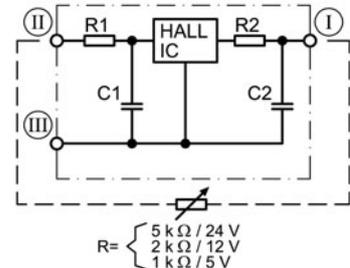

Splines: 10 x 12f (according to DIN 5481)

I Terminal 3, A
 II Terminal 4, +
 III Terminal 5, -



NIDEC MOTORS & ACTUATORS ❖❖❖ MOTOR SERIES

0291 (SWMV)

❖❖❖ DC MOTORS WITH WORM GEAR



❖❖❖ TECHNICAL DESCRIPTION

Motorhousing:	sheet metal, rolled & corrosion protected
Excitation field:	permanent magnet
Type of gear mesh:	worm gear
Gear housing:	zinc die cast
Gear wheel material:	plastic, resin bonded fabrics, steel
Lubrication:	grease
Mechanical interface:	steel shaft
Electric interface:	connector or leads
Sensor:	-
Thermal protection:	-
EMC suppression:	optional

❖❖❖ INDUSTRIAL APPLICATION

Machine construction



Design Data	
Commutation	Brushed
Direction of rotation	Bi-directional
Bearing type	A: Ball - B: Sleeve

Performance data		
Rated voltage [V]	U_N	24
Nominal torque [Nm]	M_N	6.00
No-load speed [min^{-1}]	n_0	67.0
Nominal power [W]	P_N	38.5
Nominal current [A]	I_N	5.0
Nominal force [kN]	F_N	0.00
Duty cycle	s1	

Sensor data	
Pulses	0
Output channels	0

Other data	
Gear ratio	46/1
Gear wheel material	Bronze
Suppression components	
Enclosure class	IP20
Weight [kg]	2.900

Remarks:

0291 AL

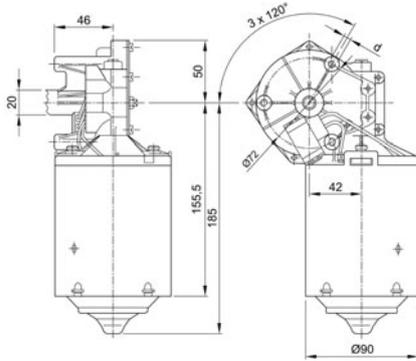

Motor picture



Characteristic curves

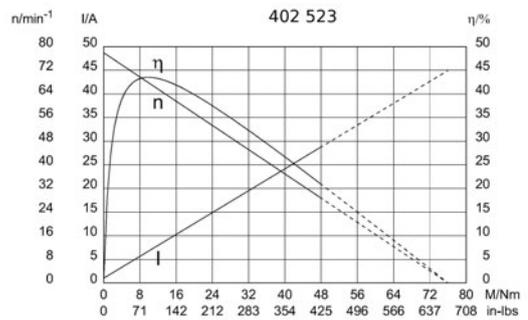

Output shaft drawing (W), Wiring diagrams (S) and Connector layout (K)

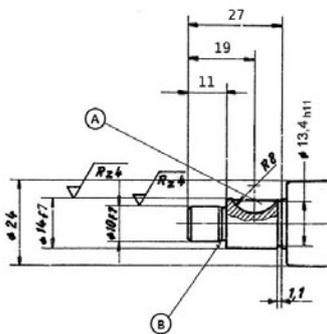

S 28

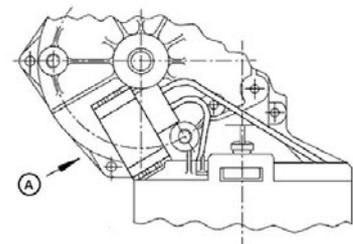
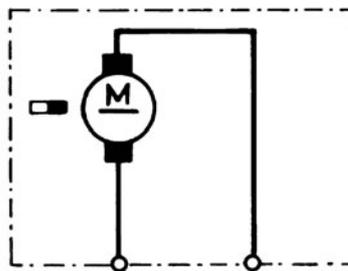

A: keyway 5 - P9 width tolerance
 B: undercut E 0.6 x 0.2 to DIN 509

A: spade ends 6.3 x 0.8 (according to DIN 46 244)

Design Data	
Commutation	Brushed
Direction of rotation	Bi-directional
Bearing type	A:Ball - B:Sleeve

Performance data		
Rated voltage [V]	U_N	24
Nominal torque [Nm]	M_N	8.00
No-load speed [min^{-1}]	n_0	78.0
Nominal power [W]	P_N	58.5
Nominal current [A]	I_N	6.0
Nominal force [kN]	F_N	0.00
Duty cycle	s1	

Sensor data	
Pulses	0
Output channels	0

Other data	
Gear ratio	46/1
Gear wheel material	Resinbonded fabric
Suppression components	
Enclosure class	IP 20
Weight [kg]	2.900

Remarks: d = M6x16mm

Characteristic curves

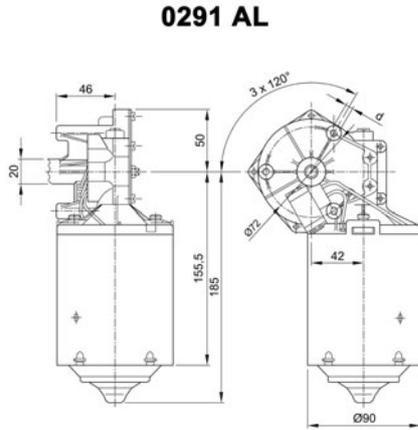

Motor picture

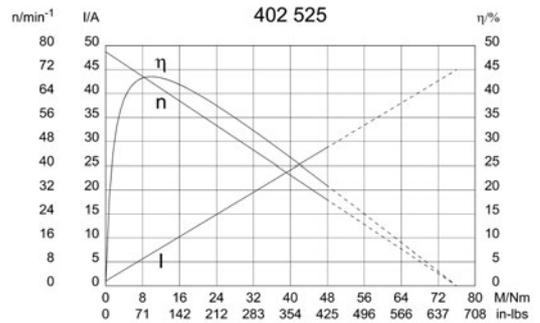

Output shaft drawing (W), Wiring diagrams (S) and Connector layout (K)

W 278

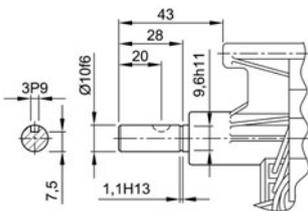

S 28

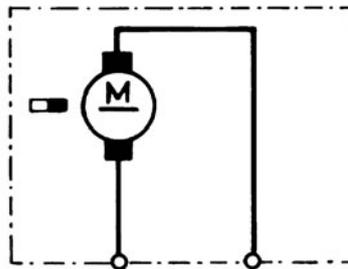

K 243

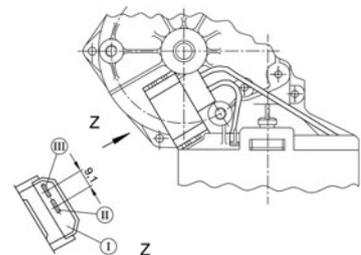

Flat plug 6,8x0,8 DIN 46244 mating with receptacle for tabs and connector housing 163 006-1, drwg C163006, www.tycoelectronics.com

Design Data	
Commutation	Brushed
Direction of rotation	Bi-directional
Bearing type	A:Ball - B:Sleeve

Performance data		
Rated voltage [V]	U_N	12
Nominal torque [Nm]	M_N	6.00
No-load speed [min^{-1}]	n_0	52.0
Nominal power [W]	P_N	29.7
Nominal current [A]	I_N	6.0
Nominal force [kN]	F_N	0.00
Duty cycle	s1	

Sensor data	
Pulses	0
Output channels	0

Other data	
Gear ratio	59/1
Gear wheel material	Resinbonded fabric
Suppression components	
Enclosure class	IP 20
Weight [kg]	2.900

Remarks: d = M6x16mm

Characteristic curves

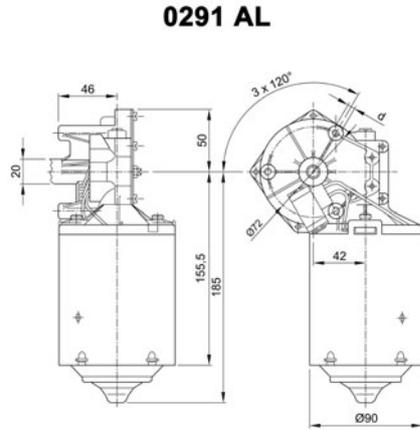

Motor picture

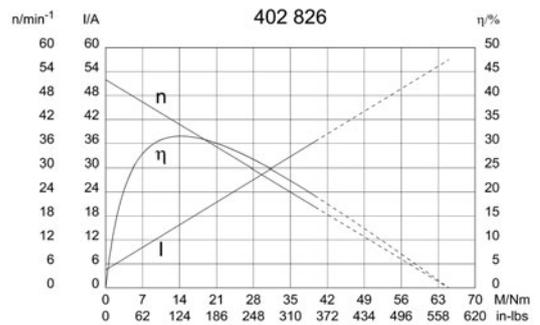

Output shaft drawing (W), Wiring diagrams (S) and Connector layout (K)

W 278

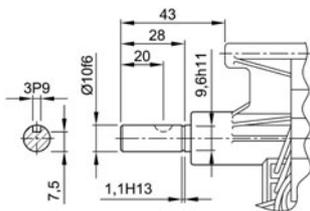

S 28

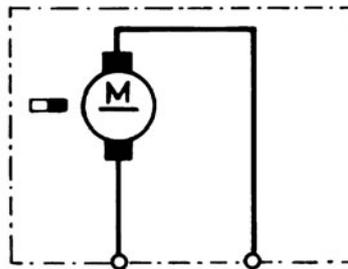

K 243

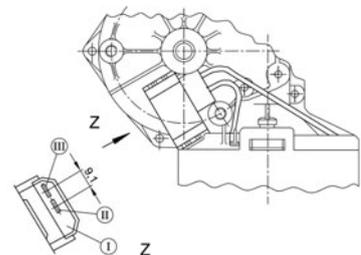

Flat plug 6,8x0,8 DIN 46244 mating with receptacle for tabs and connector housing 163 006-1, drwg C163006, www.tycoelectronics.com

Design Data	
Commutation	Brushed
Direction of rotation	Bi-directional
Bearing type	A: Ball - B: Sleeve

Performance data		
Rated voltage [V]	U_N	24
Nominal torque [Nm]	M_N	8.00
No-load speed [min^{-1}]	n_0	47.0
Nominal power [W]	P_N	34.9
Nominal current [A]	I_N	11.0
Nominal force [kN]	F_N	0.00
Duty cycle	s1	

Sensor data	
Pulses	0
Output channels	0

Other data	
Gear ratio	59/1
Gear wheel material	Bronze
Suppression components	5.0 μ H
Enclosure class	IP20
Weight [kg]	2.900

Remarks:

0291 AL

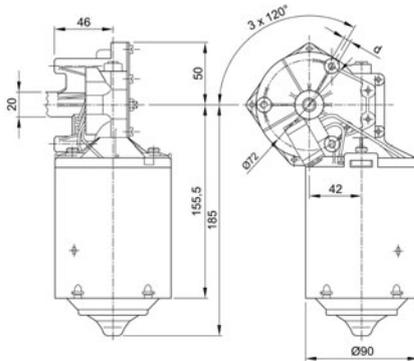

Motor picture



Characteristic curves

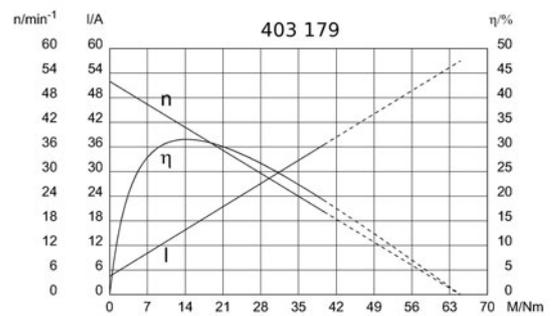

Output shaft drawing (W), Wiring diagrams (S) and Connector layout (K)

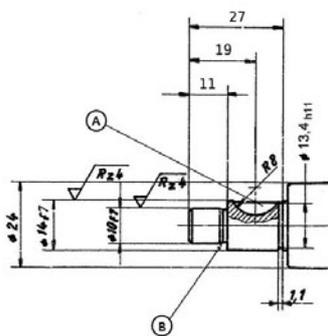

S 27

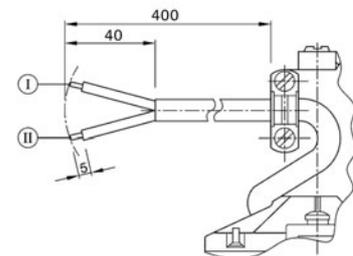
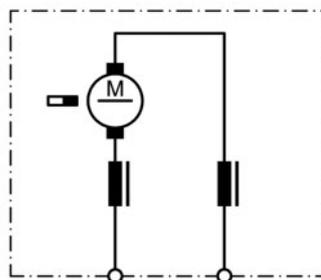

A: keyway 5 - P9 width tolerance
 B: undercut E 0.6 x 0.2 to DIN 509

I: red
 II: green

Design Data	
Commutation	Brushed
Direction of rotation	Bi-directional
Bearing type	A:Ball - B:Sleeve

Performance data		
Rated voltage [V]	U_N	24
Nominal torque [Nm]	M_N	3.00
No-load speed [min^{-1}]	n_0	220.0
Nominal power [W]	P_N	65.7
Nominal current [A]	I_N	8.0
Nominal force [kN]	F_N	0.00
Duty cycle		s1

Sensor data	
Pulses	0
Output channels	0

Other data	
Gear ratio	44/2
Gear wheel material	plastic
Suppression components	6,5 μ H, 1nF
Enclosure class	IP 20
Weight [kg]	2.900

Remarks: d = M8 x 16 mm

Characteristic curves

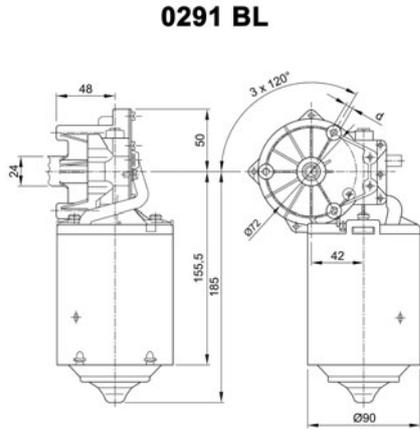

Motor picture

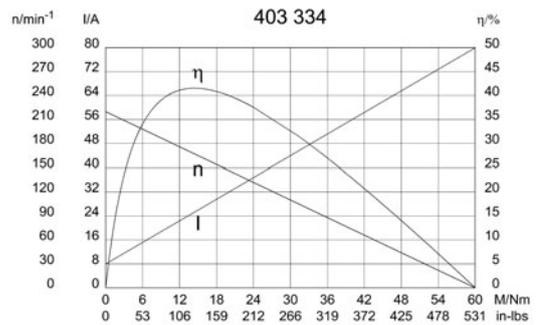

Output shaft drawing (W), Wiring diagrams (S) and Connector layout (K)

W 070

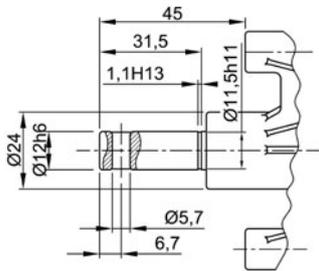

S 30

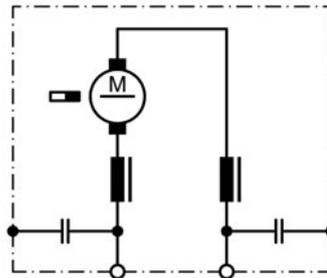

K 274

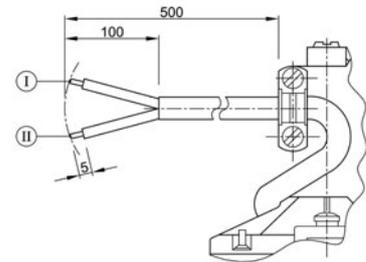

I red
 II green

Design Data	
Commutation	Brushed
Direction of rotation	Bi-directional
Bearing type	A:Ball - B:Sleeve

Performance data		
Rated voltage [V]	U_N	24
Nominal torque [Nm]	M_N	5.00
No-load speed [min^{-1}]	n_0	52.0
Nominal power [W]	P_N	25.7
Nominal current [A]	I_N	5.0
Nominal force [kN]	F_N	0.00
Duty cycle		s1

Sensor data	
Pulses	0
Output channels	0

Other data	
Gear ratio	59/1
Gear wheel material	Resinbonded fabric
Suppression components	
Enclosure class	IP 20
Weight [kg]	2.900

Remarks: d = M8 x 23mm

Characteristic curves

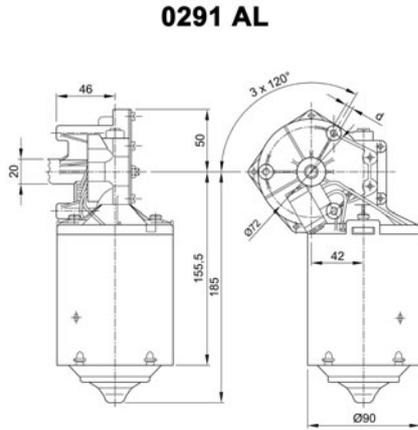

Motor picture

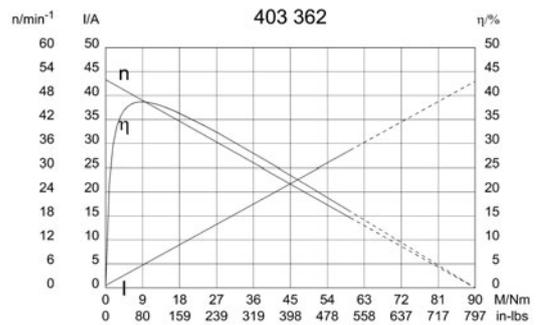

Output shaft drawing (W), Wiring diagrams (S) and Connector layout (K)

W 126

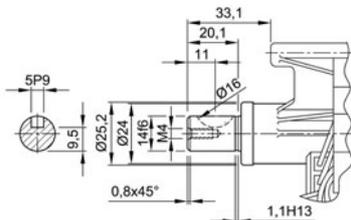

S 28

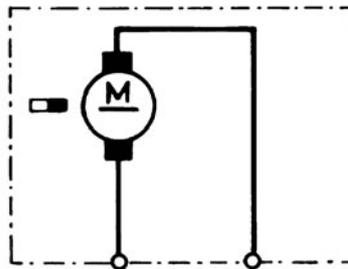

K 243

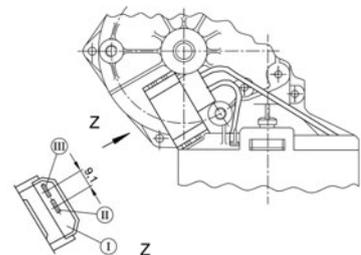

Flat plug 6,8x0,8 DIN 46244 mating with receptacle for tabs and connector housing 163 006-1, drwg C163006, www.tycoelectronics.com

Design Data	
Commutation	Brushed
Direction of rotation	Bi-directional
Bearing type	A:Ball - B:Sleeve

Performance data		
Rated voltage [V]	U_N	24
Nominal torque [Nm]	M_N	8.00
No-load speed [min^{-1}]	n_0	48.0
Nominal power [W]	P_N	36.0
Nominal current [A]	I_N	7.0
Nominal force [kN]	F_N	0.00
Duty cycle	s1	

Sensor data	
Pulses	0
Output channels	0

Other data	
Gear ratio	46/1
Gear wheel material	bronze
Suppression components	
Enclosure class	IP20
Weight [kg]	2.900

Remarks: d=M8x23

Characteristic curves

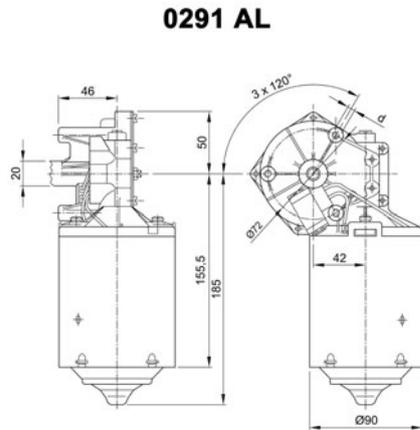

Motor picture

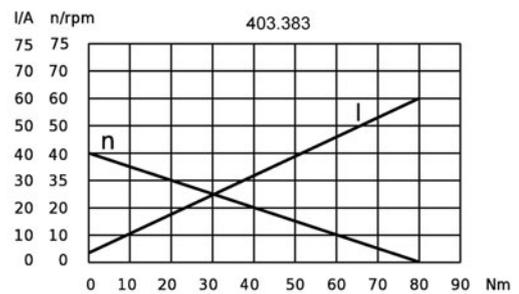

Output shaft drawing (W), Wiring diagrams (S) and Connector layout (K)

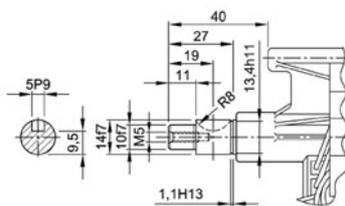

S 28

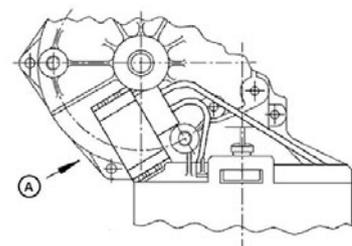
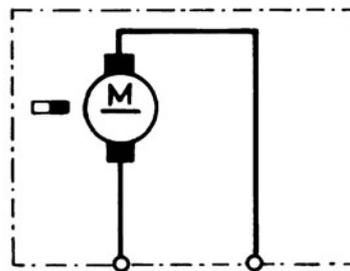

A: spade ends 6.3 x 0.8 (according to DIN 46 244)



NIDEC MOTORS & ACTUATORS ❖❖❖ MOTOR SERIES

0292 (SWMG)

❖❖❖ DC MOTORS WITH WORM GEAR

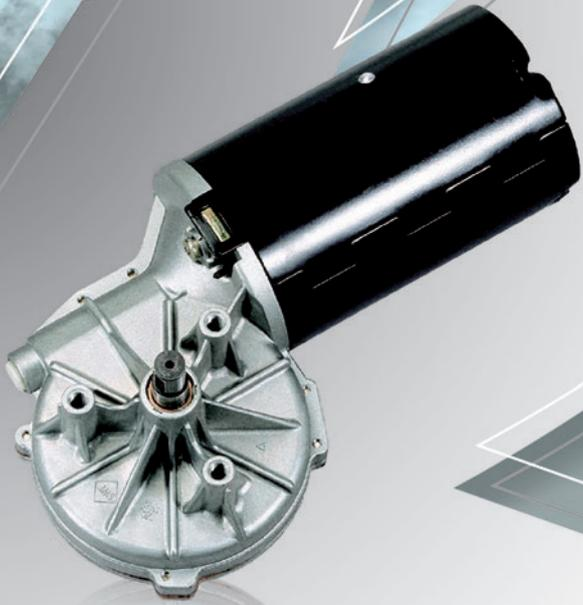

❖❖❖ TECHNICAL DESCRIPTION

Motorhousing:	sheet metal, rolled & corrosion protected
Excitation field:	permanent magnet
Type of gear mesh:	worm gear
Gear housing:	zinc die cast
Gear wheel material:	plastic, resin bonded fabrics, steel
Lubrication:	grease
Mechanical interface:	steel shaft
Electric interface:	leads with connector
Sensor:	optional
Thermal protection:	optional
EMC suppression:	optional

❖❖❖ INDUSTRIAL APPLICATION

Machine construction



Design Data	
Commutation	Brushed
Direction of rotation	Bi-directional
Bearing type	A:Ball - B:Ball

Performance data		
Rated voltage [V]	U_N	24
Nominal torque [Nm]	M_N	20.0
No-load speed [min^{-1}]	n_0	27.0
Nominal power [W]	P_N	44.0
Nominal current [A]	I_N	6.0
Nominal force [kN]	F_N	0.00
Duty cycle	s1	

Sensor data	
Pulses	0
Output channels	0

Other data	
Gear ratio	50/1
Gear wheel material	plastic
Suppression components	
Enclosure class	IP 20
Weight [kg]	4.200

Remarks:

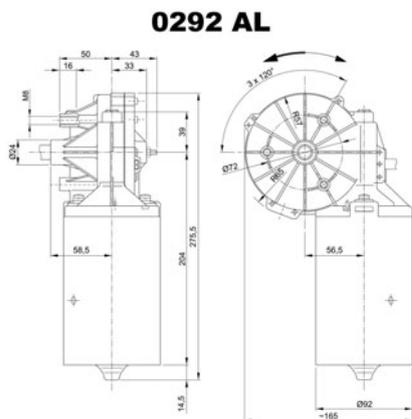

Motor picture



Characteristic curves

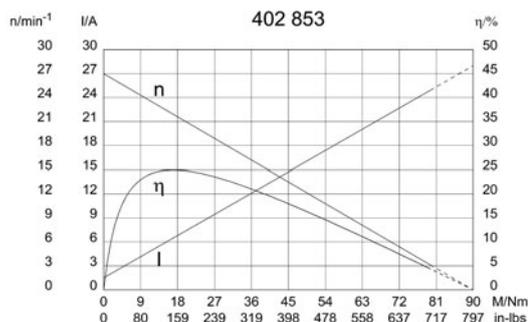

Output shaft drawing (W), Wiring diagrams (S) and Connector layout (K)

W 110

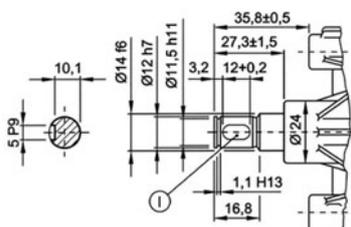

S 28

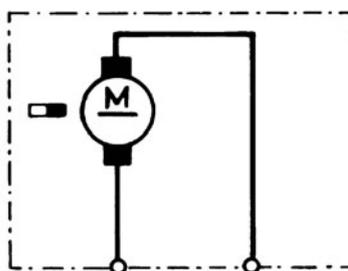

K 86

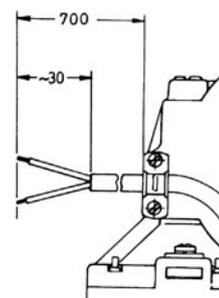

I Groove for feather key A 5x3x12 DIN 6885

Design Data	
Commutation	Brushed
Direction of rotation	Bi-directional
Bearing type	A:Ball - B:Sleeve

Performance data		
Rated voltage [V]	U_N	24
Nominal torque [Nm]	M_N	10.0
No-load speed [min^{-1}]	n_0	165.0
Nominal power [W]	P_N	156
Nominal current [A]	I_N	5.0
Nominal force [kN]	F_N	0.00
Duty cycle	s1	

Sensor data	
Pulses	0
Output channels	0

Other data	
Gear ratio	43/3
Gear wheel material	plastic
Suppression components	
Enclosure class	IP 20
Weight [kg]	4.200

Remarks:

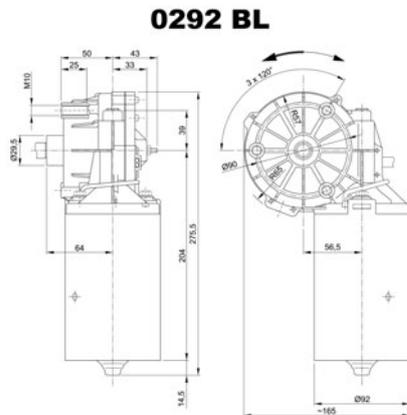

Motor picture

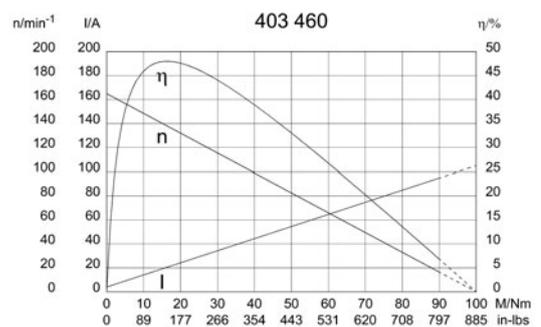

Output shaft drawing (W), Wiring diagrams (S) and Connector layout (K)

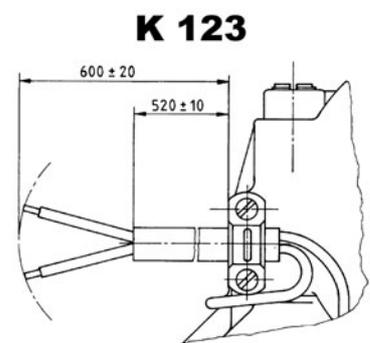
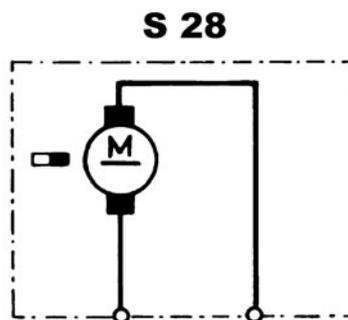
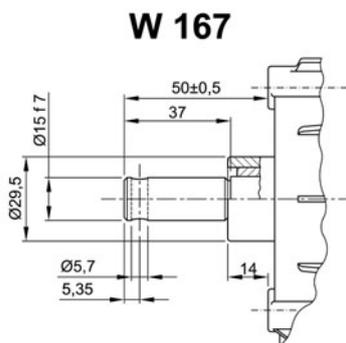



Type No.	Page	Type No.	Page	Type No.	Page
402 523	191	404 157	68	404 905	55
402 525	192	404 166	69	404 907	57
402 600	149	404 203	160	404 910	75
402 743	150	404 284	17	404 925	179
402 757	35	404 326	38	404 938	135
402 781	36	404 327	39	404 961	111
402 826	193	404 360	182	404 965	30
402 853	199	404 382	18	404 966	31
402 887	151	404 384	19	404 967	32
402 907	37	404 385	183	404 980	59
402 944	7	404 386	185	404 983	135
		404 465	41	404 987	112
403 179	194	404 469	25	404 988	114
403 187	8	404 476	9	404 990	116
403 194	79	404 536	26	404 991	118
403 279	80	404 596	27	404 992	137
403 280	81	404 603	70		
403 281	82	404 621	28	405 002	120
403 290	83	404 636	42	405 006	121
403 304	84	404 642	187	405 031	60
403 334	195	404 682	49	405 032	139
403 362	196	404 694	71	405 033	141
403 383	197	404 722	44	405 054	123
403 389	152	404 743	11	405 060	143
403 438	153	404 744	13	405 061	62
403 460	200	404 747	50	405 063	145
403 474	155	404 748	51	405 072	125
403 475	156	404 753	20	405 091	95
403 559	157	404 757	21	405 092	97
403 567	158	404 763	72	405 197	127
403 712	85	404 764	53	405 228	64
403 790	159	404 774	74	405 237	98
403 854	163	404 846	91	405 251	129
403 930	165	404 847	93	405 504	46
403 931	167	404 854	101		
403 933	169	404 864	103		
403 936	171	404 865	104		
403 939	172	404 866	106		
403 957	174	404 867	108		
403 958	176	404 868	109		
		404 872	110		
404 003	86	404 880	22		
404 127	88	404 885	133		
404 148	181	404 890	29		
404 156	67	404 904	54		

NIDEC MOTORS & ACTUATORS WORLDWIDE DISTRIBUTORS



Innovatech Solutions Pty Ltd.
19 Northwind Avenue
2250 Point Clare, NSW
Australia

Tel. +61 2 43 22 39 62
Fax +61 2 43 22 39 62
rkutter@innovatechsolutions.com.au
www.innovatechsolutions.com.au



Kwapil Co. GmbH
Kammelweg 9
1210 Wien
Austria

Tel. +43 12 78 85 85
Fax +43 12 78 85 86
verkauf@kwapil.com
www.kwapil.com



Eisses Import B.V.
Admiraal Trompstraat 11
3115 HK Schiedam
Holland

Tel. +31 1 02 46 00 18
Fax +31 1 02 46 00 19
info@eissesbv.nl
www.eissesbv.nl



Drive Systems Group
7150 Torbram Road, No 1 & 2
L4T 3Z8 Mississauga, ON
Canada

Tel. +1 90 54 05 03 10
Fax +1 90 54 05 03 13
georger@drivesystemsgroup.com
www.drivesystemsgroup.com



Opis Engineering k.s.
Selská 64
61400 Brno-Malomerice
Czech Republic

Tel. +42 05 43 33 00 55
Fax +42 05 43 24 26 53
cada@opis.cz
www.opis.cz



Bondy - LMT A&S
Grundtvigsalle 168
6400 Sonderborg
Denmark

Tel. +45 74 43 18 80
Fax +45 74 43 18 81
ej@lmttransmission.dk
www.lmttransmission.dk



Oy Movetec AB
Hannuksentie 1
02270 Espoo
Finland

Tel. +35 89 52 59 23 0
Fax +35 89 52 59 23 33
pasi.nyberg@movetec.fi
www.movetec.fi



Comotech Industries
6 rue des Blonnières
BP 82441 Haute Goulaine
44124 - VERTOU, France

Tel. +33 2 40 05 05 05
Fax +33 2 40 05 05 03
thierry.berthou@comotech.fr
www.comotech.fr



101 automation GmbH
Schallbruch 19-21
42781 Haan
Germany

Tel. +49 21 29 37 63 50
Fax +49 21 29 37 63 59
info@101automation.de
www.101automation.de



JBW GmbH
Bodenseestrasse 228
81243 München
Germany

Tel. +49 89 89 70 10 33
Fax +49 89 89 70 10 00
info@elektromotore.eu
www.elektromotore.eu



Ott GmbH & Co. KG
Baarstrasse 3
78652 Deislingen
Germany

Tel. +49 74 20 93 99 0
Fax +49 74 20 93 99 25
info@ott-antriebe.de
www.ott-antriebe.de



Wald Antriebe GmbH
Hanns-Hoerbiger-Strasse 1
29664 Walsrode
Germany

Tel. +49 51 61 60 37 07
Fax +49 51 61 60 37 08
info@waldantriebe.de
www.waldantriebe.de



Electro Mechanical Systems Ltd
Eros House, Calleva Park, Aldermaston
Reading RG7 8LN
Great Britain

Tel. +44 11 89 81 73 91
Fax +44 11 89 81 76 13
pboughey@ems-ltd.com
www.ems-limited.co.uk



Eisses Import B.V.
Admiraal Trompstraat 11
3115 HK Schiedam
Holland

Tel. +31 1 02 46 00 18
Fax +31 1 02 46 00 19
info@eissesbv.nl
www.eissesbv.nl



Strategi Automation Solutions Pvt Ltd
Plot 25/B, Dodannakundi Indl Estate,
560048 Bangalore
India

Tel. +91 80 41 16 31 36/7
Fax +91 80 41 16 30 47
arun@strategiautomation.com
www.strategiautomation.com



Mechatronics Ltd.
P.O. Box 3818
49130 Petach-Tikva
Israel

Tel. +97 2 39 28 88 88
Fax +97 2 39 28 88 80
office@mechatronics.co.il
www.mechatronics.co.il



Motech s.r.l.
Via delle Nazioni, 87
41100 Modena
Italy

Tel. +39 59 45 42 96
Fax +39 59 45 16 93
m.coda@motech-italia.com
www.motech-italia.com



Nidec-Shimpo Corp
1 Terada Kohtari, Nagaokakyo City
617-0833 Kyoto
Japan

Tel. +81 7 59 58 38 86
Fax +81 7 59 58 36 48
shinichi.takahashi@nidec-shimpo.co.jp
www.nidec-shimpo.co.jp



Eisses Import B.V.
Admiraal Trompstraat 11
3115 HK Schiedam
Holland

Tel. +31 1 02 46 00 18
Fax +31 1 02 46 00 19
info@eissesbv.nl
www.eissesbv.nl



Aratron AS
Bjornerudveien 17
1266 Oslo
Norway

Tel. +47 23 19 16 60
Fax +47 23 19 16 61
christer@aratron.no
www.aratron.no



Opis Engineering, s.r.o
Lucna 476
03202 Zavazna Poruba
Slovakia

Tel. +42 14 45 54 72 34
Fax +42 14 45 54 72 34
opis@opis.sk
www.opis.sk



Motech Iberica
Avda. de Las Cortes Valencianas, 41, 1º G
46015 Valencia
Spain

Tel. +34 9 63 45 54 05
Fax +34 9 63 46 59 31
jnavarro@motech.es
www.motech.es



KG Knutsson AB
Hammarbacken 8
19181 Sollentuna
Sweden

Tel. +46 8 92 30 20
Fax +46 8 92 33 66
dan.kimblad@kgk.se
www.kgk.se



Antrimon AG
Luzernerstrasse 91
5630 Muri (AG)
Switzerland

Tel. +41 5 66 75 40 30
Fax +41 5 66 75 40 31
info@antrimon.ch
www.antrimon.ch



S-MIKRON LTD. ŞTİ.
Nilüfer Ticaret Merkezi 66. Sokak No:8
16110 Nilüfer-BURSA
Turkey

Tel. +90 22 44 43 52 33 (Pbx)
Fax +90 22 44 43 52 42
info@s-mikron.com.tr
www.s-mikron.com.tr



Burns Controls Comp.
13735 Beta Road
Dallas TX 75244
USA

Tel. +1 97 22 33 67 12
Fax +1 97 22 33 80 39
burns@burnscontrols.com
www.burnscontrols.com



Power Electric
15300 25th Ave North, Suite 400
Plymouth MN 55447
USA

Tel. +1 76 35 53 10 90
Fax +1 76 35 53 12 42
nbohn@powerelectric.com
www.powerelectric.com

For current information, product downloads and up-to-date news and in-depth drive selection assistance, log on to our new website! Find your perfect drive with just one click: www.nidec-ma.com



- Comfortable seating thanks to the many adjuster motors in the seats.
- Motors in the sliding roof to let the sun in, and to move the roller sun blind, to keep it out.
- Electrically adjustable steering columns for optimum ergonomics.
- Adjustable spoiler for improved driving safety at higher speeds.
- Automatically controlled opening and closing of sliding doors, trunk lids or tailgates.
- Active Safety for driving and braking owing to motors in the ABS/ESP system.

NIDEC Motors & Actuators for comfort and safety in the automobile. We get things moving.

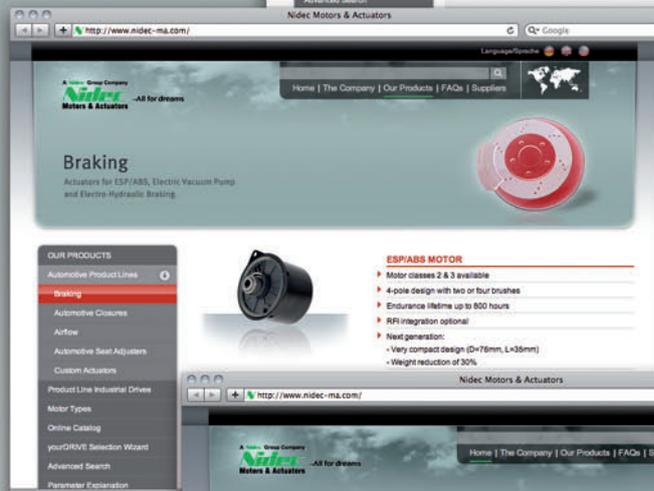
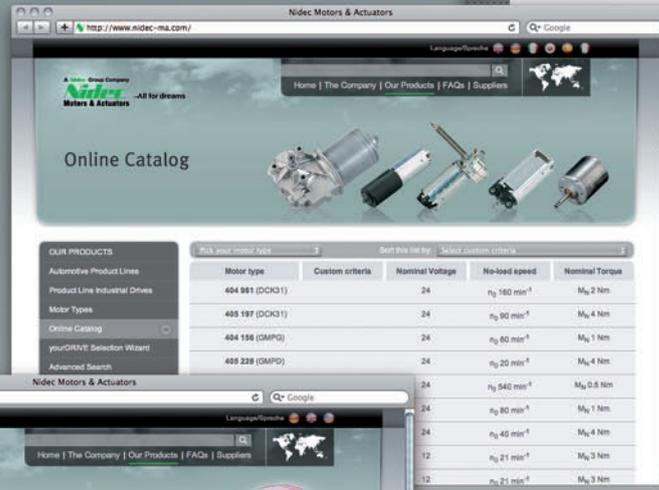

11.2010 © Copyright by NIDEC MOTORS & ACTUATORS

NIDEC MOTORS & ACTUATORS (GERMANY) GmbH

Seewiesenstrasse 9
74321 Bietigheim-Bissingen, Germany

Tel.: +49 (0) 71 42 / 508-0
Fax: +49 (0) 71 42 / 508-20 10
sales@nidec-ma.com

www.nidec-ma.com