

# DOUBLE SCISSOR LIFT

## ELECTRO-HYDRAULIC, LOW PROFILE

The low-profile double scissor lifts DF35CAT and DF30EXCAT have been specially designed for the service and repair sector. The newly designed flexible mounting platforms allow for a broad mounting range.

**+ Best corrosion protection as standard**  
**+ Very robust steel construction**  
**+ Fully matured, reliable hydraulics**

**LOW PROFILE**  
 Minimal platform height 100 mm for DF35CAT model and 105 mm for DF30EXCAT model.



**SAFETY: Mechanical lock.**



Extensible platforms to reach pick up points of the more demanding vehicles. (DF30EXCAT)



**ALWAYS LEVELLED**  
 Patented synchro valve.

Picture shows the DF30EXCAT model



**QUALITY FORGED COMPONENTS**



CE approved lift with low voltage controls.

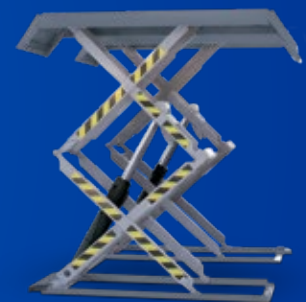

Picture shows the DF35CAT model

## HIGHLIGHTS IN DETAIL

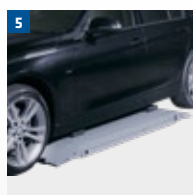
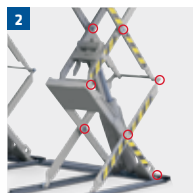

- 1** Standard cataphoresis coating with additional powder coating of the platform.
- 2** Long life: self lubricating. All pivot points made with self lubricating bushings for long life.
- 3** Broad mounting range due to newly designed flexible mounting platforms.
- 4** Easy operation of the pull-out is possible with floor-level installation.
- 5** Easy overfloor installation possible, as the platform has low clearance height.
- 6** Set of pads, H 40 mm (4 x kit).

### DF35CAT

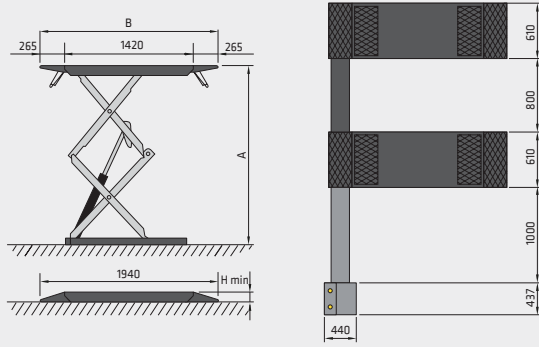

### DF30EXCAT

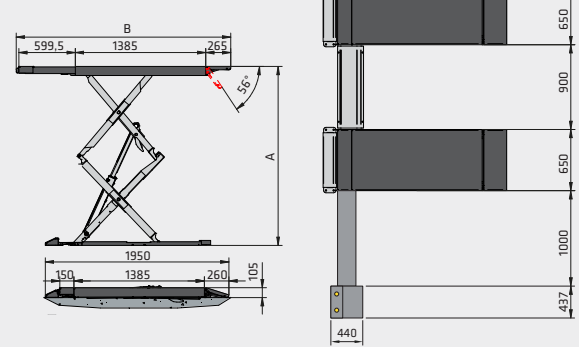

Cleanly arranged and robust push buttons ensure safe operation of the lifting platform.

Documents or tablet computers can be stored on the integrated tray system. Also perfect as a desk pad.

The pre-assembled control panel has a quiet running hydraulic unit and thus contributes significantly to a low installation effort.

Maintenance friendliness comes first: the side panels can be removed on all 4 sides, the electrical components are located underneath the hinged operating and writing console.

The tube length between the lifting platform and the console is 1 meter on the left; possible extension up to 5 meters on the left or on the right.

Model	DF35CAT	DF30EXCAT
Coating	Cataphoresis anti-corrosion	Cataphoresis anti-corrosion
Rated load capacity	3500 kg	3000 kg
<b>A</b> Stroke	1900 mm	1900 mm
<b>B</b> Platform length	1420/1950 mm	1385/2278 mm
Overall width	2020 mm	2200 mm
Lifting time loaded	35 sec.	35 sec.
Lowering time loaded	30 sec.	30 sec.
Rest height	100 mm	105 mm
Motor power	2.6 kW	2.6 kW
Power supply voltage (electrical)	3-ph, 400V 50Hz	3-ph, 400V 50Hz
Compressed air	Max. 10 bar	Max. 10 bar

## ACCESSORIES



**1** Installation kit for underfloor installation without angle iron frame.

**2** Additional ramps for sports cars, hot galvanised and powdercoated, length 860 mm (1 set / 4 pieces).

**3** Crossbar for supporting vehicles whose mounting points are located in the intermediate area of the platforms (2 x kit).

**4** Set of pads (S505A1 H= 200 mm, S505A5 H= 120 mm, S505A9 H= 60 mm, S505A7 H= 20 mm).

